







THE

1

2750/1

2nd

PRACTICAL MECHANIC'S JOURNAL.

VOLUME VI.

APRIL, 1853—MARCH, 1854.

“To pass our time in the study of the Sciences, in learning what others have discovered, and in extending the bounds of human knowledge, has, in all ages, been reckoned the most dignified and happy of human occupations.”—BROUGHAM.

“To avail ourselves, as far as possible, of the advantages which a division of labour may afford for the collection of facts, by the industry and activity which the general diffusion of information, in the present age, brings into exercise, is an object of great importance. There is scarcely any well-informed person who, if he has but the will, has not also the power to add something essential to the general stock of knowledge, if he will only observe, regularly and methodically, some particular class of facts which may most excite his attention, or which his situation may best enable him to study with effect.”—HERSCHEL.

“A man, uneducated or unlettered, may sometimes start a useful thought, or make a lucky discovery, or obtain, by chance, some secret of Nature, or some intelligence of facts, of which the most enlightened may be ignorant, and which it is better to reveal, though by a rude and unskilful communication, than to lose for ever by suppressing it.”—JOHNSON.

LONDON: PUBLISHED FOR THE PROPRIETORS BY
GEORGE HEBERT, 88 CHEAPSIDE.

GLASGOW: 166 BUCHANAN STREET.

OFFICES OF THE PRACTICAL MECHANIC'S JOURNAL,
(PATENT OFFICES,)

47 LINCOLN'S INN FIELDS, LONDON, AND 166 BUCHANAN STREET, GLASGOW.

DUBLIN: J. M'GLASHAN, 50 UPPER SACKVILLE STREET.

NEW YORK: STRINGER AND TOWNSEND, 225 BROADWAY.

OFFICES FOR
BRITISH AND FOREIGN PATENTS



47 LINCOLN'S INN FIELDS, LONDON,

AND

166 BUCHANAN STREET, GLASGOW.

AND THE

REGISTRATION OF DESIGNS,

All Business relating to Letters Patent may be transacted at these Offices.

CAVEATS ENTERED. SEARCHES MADE FOR SPECIFICATIONS, AND ABSTRACTS OR COPIES SUPPLIED.
SPECIFICATIONS DRAWN OR REVISED. MECHANISM DESIGNED, AND DRAWINGS MADE BY COMPETENT DRAUGHTSMEN.
PROLONGATIONS AND CONFIRMATIONS SOLICITED. DISCLAIMERS ENTERED. ADVICE ON THE PATENT LAWS.
OPINIONS ON INFRINGEMENTS. THE NOVELTY OF INVENTIONS ASCERTAINED.
DESIGNS, DEVICES, AND PATTERNS, AND THE CONFIGURATION OF ARTICLES OF UTILITY, PROTECTED COMPLETELY OR PROVISIONALLY.

THE NEW PATENT LAW.

The Act 15 & 16 Vict. cap. 83, which effects the greatest reform in the practice of obtaining, and in the cost of Letters Patent, is now in force. The chief alterations are—

First: One grant of Letters Patent extends over the whole of the United Kingdom.

Second: A Preliminary Protection for Six Months is given, upon application, at an average cost, including agency, of £10. 10s.

Third: The payments for Letters Patent are to be made at three periods; on obtaining the grant, and at the expiration of Three Years, and of Seven Years.

Further information may be obtained on application to Messrs. W. & J. H. JOHNSON, as above.

Agent for Preston and North and East Lancashire, WM. GILBERTSON, 40 Fishergate, Preston.

Newcastle-upon-Tyne: WM. SHAND, Bank Buildings.

Paris: M. ARMENGAUD, Ainé, Rue St. Sébastien, 45-

Just Published, price 5s.,

The Patentee's Manual;

BEING

A TREATISE ON THE LAW AND PRACTICE OF LETTERS PATENT,
ESPECIALLY INTENDED FOR THE USE OF PATENTEES AND INVENTORS.

BY

JAMES JOHNSON, Esq., OF THE MIDDLE TEMPLE, AND

J. HENRY JOHNSON, SOLICITOR AND PATENT AGENT, 47 LINCOLN'S INN FIELDS, AND GLASGOW.

This Work has been carefully compiled to meet the requirements of the non-professional reader, the aim of the writers being to place before the intending Patentee the result of the numerous important decisions of the Law Courts, in as clear a form as possible, and totally devoid of the puzzling legal technicalities which so often occur in treatises of this nature. The RECENT PATENT LAW AMENDMENT ACT is given, and the routine of the proceedings under it.

Also, Just Published, price 6d.,

An Abstract of the Patent Law Amendment Act, 1852,

WITH OBSERVATIONS THEREON, FOR THE USE OF PATENTEES AND INVENTORS.

By W. JOHNSON, Assoc. Inst. C. E., Editor of the 'Practical Mechanic's Journal,' and

JOHN HENRY JOHNSON, Solicitor, Patent Agents.

Now Ready, complete in One Volume Cloth, Gold Lettered, price £1. 9s.,

The Practical Draughtsman's Book of Industrial Design;

FORMING A COMPLETE COURSE OF

Mechanical, Engineering, and Architectural Drawing.

Translated from the French of

M. ARMENGAUD, Ainé, Professor of Design in the Conservatoire Des Arts et Métiers, Paris, and

MM. ARMENGAUD, Jeune, and AMOUROUX,

CIVIL ENGINEERS,

Re-written and Arranged, with additional Matter and Plates,

By WILLIAM JOHNSON, Assoc. Inst. C.E., Editor of the "PRACTICAL MECHANIC'S JOURNAL."

TO WHICH ARE ADDED,

SELECTIONS FROM AND EXAMPLES OF THE MOST USEFUL AND GENERALLY EMPLOYED MECHANISM OF THE DAY.

GENERAL CONTENTS.

LINEAR DRAWING.
THE STUDY OF PROJECTION.
ON COLOURING SECTIONS, WITH APPLICATIONS.
THE INTERSECTION AND DEVELOPMENT OF SURFACES, WITH APPLICATIONS.
THE STUDY AND CONSTRUCTION OF TOOTHED GEAR.
ELEMENTARY PRINCIPLES OF SHADOWS.
APPLICATION OF SHADOWS TO TOOTHED GEAR

THE CUTTING AND SHAPING OF MASONRY.
THE STUDY OF MACHINERY AND SKETCHING.
OBLIQUE PROJECTIONS
PARALLEL PERSPECTIVE.
TRUE PERSPECTIVE.
EXAMPLES OF FINISHED DRAWINGS OF MACHINERY.
DRAWING INSTRUMENTS.

The Volume contains 105 Quarto Pages of splendidly-executed Plate Engravings, about 60 Woodcuts, and 200 Pages of Quarto Letterpress.

LONDON: LONGMAN, BROWN, GREEN, AND LONGMANS.

EDITORS' OFFICES (OFFICES FOR PATENTS AND DESIGNS),

47 LINCOLN'S INN FIELDS, LONDON, and 166 BUCHANAN STREET, GLASGOW.

I N D E X .

	PAGE		PAGE		PAGE
A					
Aerated Water Apparatus, Gaillard & Dubois' "Gazogene," or,	87	Boilers and Boiler Explosions, Fairbairn on,	75	Colours, Professor Helmholtz on the Mixture of Homogeneous,	215
Aerated Water Apparatus, Mathieu's,	69	Boilers, Feed-apparatus for Steam,	170, 190	Combing Gill Drawing Frame, Lawson's,	173
Age we Live in, The,	273	Boilers, Harrison's Steam-engines and,	16	Combing of Fibrous Materials, Mr. Fothergill on the,	242
Agriculture, with some account of his own operations at Tiptree Hall Farm, Mr. J. J. Mechi on British,	286	Boilers, Pearce's Improved,	231	Composite Cutting Tools, Renshaw's Patent,	60
Air Motive Engines, Napier & Rankine's,	235	Boilers, Sketleton's Upright Tubular,	245	Composite Metal, Chamero's,	114
American Industrial Capabilities, an American Opinion on,	125	Bottles, Scott's Screw-stoppered,	165	Cooking Apparatus, Rae's Gas-heating and,	139
Amsterdam, International Society of Industry, Agriculture, and Commerce, at,	54	Braiding Machine, Booth's Plaiting and,	202	Cooking Range, Little's,	172
Angle-Iron Shearing and Punching Machine, Duplex Action of,	278	Braiding Machine, Plaiting and,	239	Cooling Air in Tropical Climates, Rankine's Report on the Means of,	194
Art, Marlborough House Central School of,	269	Braid Machine, Service's Elastic,	153	Cork-cutting by Machinery,	179
Arts, Society of,	269	Brick Machine, American Dry Clay,	242	Cotton for Beds, Elasticated,	220
Atkins' Self-raking Reaping Machine,	8	Brick Machines, Heritage's Water Die for,	280	Cotton Gin, Burn's Roller,	76
Atmospheric Impurity with Disease, M'Connell on the Connexion of (Review),	239	Brick Machinery, Lord Berriedale's Improvements in,	34	Cotton-Seed Oil,	290
Axle-box, Adam's Railway Carriage,	150	Brickmaking Machine, Clayton's,	268	Cotton-spinning—Eccles v. M'Gregor—Action for Infringement,	125
Axle-box, Barrans' Railway,	245	Bricks and Pottery, Elliot's Ironstone,	67	Coupling for Shafting, Hunt's Governor for Prime Movers and Screw Propellers, and Spring,	277
Axle, French's Railway,	197	Bridge on the Great Northern Railway, Mr. Cubitt's Description of the Newark Dyke,	98	Cranes, James' Weighing Machines and Weighing,	42
Axles, M'Connell's Locomotive Engines and Railway,	23	Bridge over the Clyde at Glasgow, Suspension, "Brilliant," Madeira Packet Brig, as an Auxiliary Screw Steamer, The,	62	Crayon Daguerreotypes, Mayall's,	45
B					
Bands for Machinery, Paton's Composite Driving,	173	Brooches, Taylor's,	168	Crystal Palace, The New,	225
Barrow, Ellis' Navigator's,	232	Brushing and Cleansing Machines, Clough's,	15	Curiosities of Mechanical Negligence,	54
Battery, Revolving Gun,	284	C			
Battery, Springfellow's Pocket,	244	Candles, Palmer v. Wagstaff—Action for Infringement, Palmer's,	125	Danks and Walker's New Cut Nail Machinery,	251
Beet-root Rasping Machines, Self-acting Feeder for,	15	Candlesticks and Lamps, Ogilvie's,	67	Decimal Coinage, Millward on the (Review),	238
Beet Sugar Works, Irish,	28	Candlewicks, Card's Manufacture of,	165	Dental Instruments, Young's,	185
Bellhouse's "Twin" Steam-boiler,	131	Caoutchouc, Goodyear's (U.S.) Patent for Vulcanizing,	29	Digger, Samuelson's Rotatory,	111
Berdan's Gold Ore Pulveriser and Amalgamator,	173	Caoutchouc, Johnson's Manufacture of,	161	Distributor and Miner, Davison and Horrocks,	256
Berriedale's Continuous-action Loom for Narrow Fabrics, Lord,	85	Capsicum Grinding,	239	Distributor, Spooner's Combined Seed, Manure, and Liquid,	279
Berriedale's Improvements in Brick Machinery, Lord,	34	Carding Engine, Self Top-stripping,	245	Distributor, Tasker's Manure,	280
Blasting Cartridge, Norton's Percussion,	78, 195	Carpet Manufacture, Crossley v. Potter—Action for Infringement,	124	Dog-cart, Begbie's Adjustable,	141
Blast to Smelting Furnaces, On the Application of the,	71	Carriage, Gordon's Improved,	182	Drainage, Dry Manure from London,	148
Block-printing for Calico, Sandiford's,	89	Carriages and Wheels, Davis',	166	Drainage of Cities,	291
Blowing and Exhausting Fans, Chaplin's,	209	Carriages, Emery's Basketwork,	233	Drainage of the District South of the Thames, Mr. J. T. Harrison on the,	285
Boat, Astley's Life or Surf,	59	Carriage Windows, The Mechanism of,	283	Drainage of Towns, Mr. Rawlinson on the,	51
Boat Gear for Ships, Wymer's System of,	278	Cartridge, Norton's Percussion Blasting,	78, 195	Drainages, Brooks on the Improvement of Tidal Navigations and,	73, 74
Boats, Lipscombe's Ships and,	282	Case-cleaning Machine, Davison's Patent,	232	Draining Level, Weir's,	255
Boats, Russell's Plan for Lowering Ships',	256	Casks, Robertson's Manufacture of,	234	Drain Pipes, Mackay's,	137
Boiler, Barrans' Cup-surface,	160	Casting-ladles, Ironfounders',	72	Draughtsman's Book of Industrial Design, The Practical (Review),	26
Boiler, Bellhouse's "Twin" Steam,	131	Century of Inventions, Some Account of the Marquis of Worcester's,	5, 35	Drawing Pen, Renshaw's Secondary Adjustment,	220
Boiler, Cameron's Conical Fire-box,	260	Charcoal Kilns, and Vacuum Sugar Pans,	63	Dress and Ornamental Fastenings, Taylor's,	168
Boiler Explosions, Sloan and Leggett's Hydrostat for preventing,	156	Chimney-tops and Flues, Lister's,	260	Dressing and Sizing Machines, Bashall's,	210
Boiler, Glasson's Improved Oval Tubular,	160	China, a Field for British Engineering,	172	Drill, Calvert's Universal Ratchet,	262
Boiler, Holcroft and Hoyle's Small Diameter Steam,	278	Chivalry of Intellect, The,	244	Drying Apparatus, Chapelle's,	63
Boiler, Lefroy's Combined Gas and Steam,	189	Chronometers, Philcox' Marine,	261	Dublin Winter Garden,	290
		Churn, M'Lellan's Emigrant's,	290	"Duncan Hoyle" steamer, Direct-action Inclined Engines of the,	110
		Cinder-basket, Walker's,	45	Duplex Pressure Fan, Chaplin's,	64
		Cleopatra's Needle, Transport of,	26	Dyewood, Mucklow's Machine for Rasping,	188
		Clockwork, Millar's Turret,	117		
		Clothes, Steam Washing for,	149		
		Coal? What is,	172		
		Coleman's India-rubber Springs,	97		
		College, Birmingham, Queen's,	53, 196		

	PAGE		PAGE		PAGE		
Dynamometer for Ploughs, Bentall's Self-registering,	219	Forging, Stenson's Improvements in Scrap-iron,	219	Home Resorts for Invalids, On the Climate of Guernsey, By S. E. Hoskins, M.D., (Review,)	263		
E							
Elastic Scales for Thermometers, Mackenzie and Blair's,	68	Forging-Machine, Richards' Metal,	88	Hose, Weir's Waterproof Canvas,	255		
Electrical Illumination, Dr. Watson's Electric Lamp,	57	Form in the Decorative Arts. By M. Digby Wyatt, Esq., An Attempt to Define the Principles which should Determine, (Review,)	262	Houses, Walker's Portable,	162		
Electrical Illumination, Dr. Watson's Remarks on the Present State and Prospects of (Review),	122	France, Society for the Encouragement of National Industry in,	161	Human Frame, R. D. Hay on the Geometrical Principles involved in the Construction of the,	28		
Electric Induction, Professor Faraday on,	288	French Inventions, Recent: "Safety Paper" for Preventing Forgery—Platina-plating—Electric Smelting—Cave's Compensating Marine Engines—Ornamental Incrustation in Glass,	256	Hydrostat for Preventing Steam-boiler Explosions, Sloan and Leggett's,	156		
Electric Clock Apparatus, Dr. Lover's "Contact Breaker" and,	154	Fuel, Pridaux' Rudimentary Treatise on, (Review,)	237	Hydrostatic Pressure, Weems' Manufacture of Pipes and Sheets by,	108		
Electricity, Pichon's Method of Smelting by,	257	Fuel-works at Blanzv, Artificial,	109	I			
Electricity; Telegraphic Longitude,	289	Furnaces, Higgins' Water-space Door-frames for,	24	Illumination and Heating, Dix's Artificial,	44		
Electric Light, Electrode Adjustment for the,	124	Furnaces, Jones' Iron-refining and Puddling,	81	Inclinometer, or Level, Gillespie's,	86		
Electric Light, The,	29	Furnace, Stevens' Smokeless,	43	Indicator for Registering Numbers, Distance, and Time, Norton's,	28		
Electric Semaphore for use on Railways, Ward on an,	218	Furniture, Brown's Portable,	140	Indicator, On the Occasional Oscillations of the Steam Pressure,	10, 40		
Electric Telegraph Company in Ireland, The,	150	G					
Electric Time Ball for the Clyde,	293	Galvanic Batteries, Kukla's,	193	Industrial College for Artizans, Twining's Notes on the Organization of (Review,)	263		
Electro-Magnetic Engine, Turton's,	192	Gas-burners, Johnson's,	137	Industrial Courts at the Sydenham Exhibition,	290		
Electro-Magnetic Motive Power,	265	Gas-burners, Laidlaw's,	70	Industrial Drawing, Mahan's (Review,)	237		
Elliptic Rotatory Engine, Duplex,	24	Gas-heating and Cooking Apparatus, Rae's,	139	Industrial Exhibitions, Dublin, New York, Edinburgh, and Paris,	77		
Elliptic Rotatory Engine, Wright and Hyatt's,	265	Gas-lights applied to Ventilation, Brown's,	91	Industry in France, Society for the Encouragement of National,	161		
Emigrant's Churn, M'Lellan's,	290	Gas, Quality of London,	220, 267	Infringement, Carpet Manufacture, Crossley v. Potter, Action for,	124		
Engineering, China a Field for British,	172	Gas Retorts, and Combined Gas Apparatus, Bowers',	105	Infringement, "Continuous Check Strap" for Power Looms, Action for,	292		
Engineering on the Thames, Marine,	28	"Gazogene," or Aerated-water Apparatus, Gaillard and Dubois',	87	Infringement, Cotton-spinning, Eccles v. M'Gregor, Action for,	125		
Engineers, R.N. Retiring Pensions to,	126	Geographical Society, Map-room of the Royal,	148	Infringement, Holland's Patent Umbrellas,	245		
Engineer's Shaping Machine, Renshaw's,	230	Geology, Outlines of, VI. and VII.,	65, 83	Infringement—Manufacture of "Flyers," Onions v. Crowley—Action for,	173		
Engines of the "Duncan Hoyle" steamer, Direct-action Inclined,	110	Glasgow Agricultural Society and City Sewerage, The,	244	Infringement—Manufacture of Steel—Heath v. Smith—Action for,	197		
Envelope, Waterlow & Son's American,	233	Glass Bottles and Jars, Wilson's,	92	Infringement—Palmer's Candles, Palmer v. Wagstaff—Action for,	125		
Ether Engine, Rennie on the combined Steam and,	217	Glass, Gille's System of Ornamentation in,	258	Infringement—Tuhe Manufacture, Bower v. Hodges, et Al.—Action for,	148		
Evaporating and Concentrating Apparatus, Higginson's,	258	Glass, Shaw on the Manufacture of (Review,)	48	Ink-bottle, Blackwood's,	212		
Exhibition, 1853, The Great Industrial,	129, 153	Gold—its Properties, Combinations, Testing, Extraction, and Applications,	253	International Society of Industry, Agriculture and Commerce at Amsterdam,	54		
Exhibition, 1853, The New York,	126, 177	Gold-ore Pulveriser and Amalgamator, Berdan's,	173	Inventions, and the effect of such laws on the Arts and Manufactures, Mr. T. Webster on Laws relating to Property in Designs and Inventions,	287		
Exhibition, Industrial Courts at the Sydenham,	290	Gold-sifter, Lambert's,	48	Inventions, Some Account of the Marquis of Worcester's Century of,	5, 35		
Exhibition, Mr. Cole on the International Results of the Great,	51	Goodyear's (U.S.) Patent for Vulcanizing Caoutchouc,	94	Inventions—The Claims of Originators,	249		
Exhibition of 1851, and Schools of Design, Report of the Commissioners for the,	25	Governor for Prime Movers and Screw Propellers, and Spring Coupling for Shafting, Hunt's,	277	Inventors, Gallery of,	268		
Exhibition of the Royal Academy, The,	58	Governor for Steam-engines, Luttgen's Differential-action,	274	Irish Engineering Company's Portable Steam-engine, The,	205		
Exhibitions, Dublin, New York, Edinburgh, and Paris, Industrial,	77	Governor for Steam engines, Pipe and Ball,	150	Irish Fisheries,	153		
Exhibitions, The New York and Moscow,	147	Governor, New Form of Vane,	53	Iron for Shipbuilding, M'Gavin's Manufacture of,	164		
Exhibition, The Society of Arts,	231, 255	Governor, Siemens' Improved Chronometrie,	227	Ironfounders' Casting-lades,	72		
Express Locomotive on the London and North-Western Railway, M'Connell's,	180, 201	Governor, Steam-pressure,	123	Iron in Scotland, Consumption of Pig,	125		
F							
Fabrics, Knox's Duplex Pattern,	166	Grain, Kilm-drying,	106	Iron-Refining and Puddling Furnaces, Jones',	81		
Fan, Chaplin's Duplex Pressure,	64	Grape Disease, Dr. A. P. Price on the Employment of the Higher Sulphides of Calcium, as a means of Preventing and Destroying the Oidium Tuckeri,	193	Ironstone Bricks and Pottery, Elliot's,	67		
Feed Apparatus for Steam Boilers,	170	Grape Disease, The Madeira,	12	Iron-works, Darling's Malleable,	180		
Ferrule and Safety Valve Lever, Cawood and Sunter's,	73	Grate, Rotatory Fire,	172	J			
Figured Fabrics, Cochrane's,	164	Grates, Feret's Reflecting Fire,	173	Jacquard Machinery, Houston's Improvements in,	53		
Filter, Mill's Combined Refrigerator and,	256	Gravitation, and the Doctrine of Ratios to the Measurement of the Solar System, Application of the Principles of,	50	Japan, The American Expedition to,	29		
Fire-arms, Needham's Breech-loading,	23	Guages, Fife's Steam and Water,	91	Jet-Pump, Thomson's,	217		
Fire Engines, Shand and Mason's Ship,	101	Guano, Pettitt's Artificial or Fish,	195	Jute, Capper's Method of Bleaching,	137		
Fire Grates, Finlay's,	66	Gu Battery, Revolving,	284	K			
Fireproof Laths,	284	H					
Fisheries, Guano, H. Green on Pettitt's,	286	Hammer, Brown's Steam,	133	Key, Ratchet Brace, and Self-adjusting Screw,	284		
Fish Guano, Pettitt's Artificial or,	195	Hammer, Condie's Steam,	191	"Kitchener," Harrison, Radclyffe, and Blunt's,	221		
Fish Joints for T Rails,	264	Harman's Tubular-framed Hoist,	107	Knitting, Nottingham Framework,	269		
Fish Manure as a Substitute for Guano, Mr. J. B. Lawes on,	287	Hat, Flanagan's Eolian,	122	L			
Flax Gill, Westley's "D,"	184	Health Committee of the Borough of Liverpool on the Sewerage, Paving, Cleansing, and other Works, under the Sanatory Act, Newlands' Report of the (Review,)	213	Lamp, and on the invention of the Safety Lamp, Dr. Glover on a new Safety,	286		
Flax Plant, Prof. Hodge's Report on the Gases evolved in Steeping Flax, and on the Composition and Economy of the,	193	Heliostat, Forster's,	123	Lamp, Dr. Watson's Electric,	57		
Flour-Mills, Currie's Patent,	232	Hoe, Martin's Revolving Turnip,	77	Lamps, Ogilvie's Candlesticks and,	67		
Flushing Apparatus, Adamson's,	234	Hoist, Harman's Tubular-framed,	107				
"Flyers"—Onions v. Crowley—Action for Infringement—Manufacture of,	173						
Fog-Bells for Steamers, Reflecting,	240						
Food, Concentrated Articles of,	196						
Forces, The Parallelogram of,	144						

	PAGE		PAGE		PAGE
Lamps, Thomson's Ship, Barrack, and Telegraph,	113	Strength, and the Causes of Deterioration, Fairbairn's Report on the Mechanical Properties of,	217	Patents, Provisional Protection for Inventions, 29, 54, 78, 101, 126, 150, 174, 198, 221, 246, 269, 293	
Laths, Fireproof,	234	Metal Working and Ornamentation, with some allusion to the newly-discovered Art of Nature Printing, Mr. W. C. Aitken on Ancient and Modern,	288	PATENTS, RECENT:—	
Law Amendment Act, 1852, Patent,	252	Meters, Keenedy's Motive Power and,	46	Aerated Water Apparatus: F. Mathieu,	69
Law as to Patents for Inventions in Austria,	276	Milk as a Manufacturing Ingredient,	77	Agricultural Steam-Engines: W. Allchin,	113
Do. in Bavaria,	203	Milk, Fadeuilhe's Patent Solidified,	55	Air Motive Engines: J. R. Napier and W. F. M. Rankine,	235
Do. in France,	3	Milk, Removal of the Turnip Flavour in,	195	Bleaching, Jute: J. Capper and T. J. Watson,	137
Do. in the German States of the Zollverein,	106	Millstones, Barnett's Permeable,	155	Block-printing for Calico: R. Sandiford,	89
Do. in Prussia,	131	Millstones, French,	ib.	Block Sheaves: A. Brown,	69
Do. in Russia,	227	Mines, Clough's Safety Apparatus for,	213	Blowing and Exhausting Fans: A. Chaplin,	209
Do. in Spain,	251	Mines in Cornwall, Government School of,	290	Boiler, Conical Firebox: J. Cameron,	260
Do. in the United States of America,	39	Mines, Norcombe's Safety Apparatus for,	214	Bottles, Screw-stoppered: J. Scott,	165
Do. in Wurtemberg,	183	Minig Borer, Thomson's American,	149	Brick Machines, Water Die for: J. Heritage,	230
Law of Patents, Wordsworth's Summary of the (Review),	144	Moral Sanatory Economy, by H. M'Cormac, M.D. (Review),	239	Bricks and Pottery, Ironstone: W. G. Elliott,	67
Laws, American Patent,	169	Motive Engines, Napier and Rankine's Air,	235	Brushing and Cleansing: C. B. Clough,	15
Law, The New Patent,	159	Motive Power. J. Anderson,	165	Buildings, Portable: J. H. Porter,	69
Level, Gillespie's Inclinator, or,	86	Moulding in Metal, Hoby and Kinniburgh's Method of,	262	Candlesticks and Lamps: G. S. Ogilvie,	67
Library Desk, or Devonport, Allen's,	212	Moulding in Metal, Julian Bernard's Method of,	259	Candlewicks, Manufacture of: N. Card,	165
Life-Boat, Colonel Chesney on the Tubular Double,	217	Museums, Libraries, and Picture Galleries (Review),	49	Caoutchouc, Manufacture of: W. Johnson,	161
Life-Boat, Hutchins',	228			Carriages and Wheels: M. Davis,	166
Life-Boat, Roberts',	217	N		Carriages, Basket-work: J. Emery,	233
Life or Surf Boat, Astley's,	59, 73	Nail Manufacture, The Cut,	251	Casks, Manufacture of: J. Robertson,	234
Life Raft, Parratt's Tubular,	287	Newspaper Stamping Machines at Somerset House, Hill's,	2	Chimney Tops and Flues: R. Lister,	260
Light, Lord Brougham's Experiments and Observations on the Properties of,	98	Newspaper Stamps in the Forms, Printing,	220	Chronometers, Marine: G. Pbilcox,	261
Lights, Relative Purity and Generation of Heat of Artificial,	125	New York Exhibition, 1853, The, 126, 147, 177		Cinder-basket: M. Walker,	45
Literature, Science, and Art in the House of Commons,	126	Norton's Percussion Blasting Cartridge, . 78, 195		Clearing Apparatus for Yarn: W. Stevenson,	207
Locks, Mr. A. C. Hobbs on the Principles and Construction of,	285	Norton's Projectiles, Captain, . 28, 90, 147		Clockwork, Turret: C. Millar,	117
Lock-Spindle, Cavanagh's Tubular Adjusting,	255	Norton's Railway Danger Signals, Captain, . 245		Composite Metal: E. A. Chamberoy,	114
Locomotive Engines and Railway Axles, M'Connell's,	23	Nottingham Framework Knitting,	269	Daguerreotypes, Crayon: J. E. Mayall,	45
Locomotive Engines, M'Connell's,	186			Dental Instruments: J. A. Young,	185
Locomotive Engines, Stubbs and Grylls',	22	O		Distributor, Combined Seed, Manure, and Liquid: W. C. Spooner,	279
Locomotive Expenses on the Eastern Counties Railway,	146	Oil, Cotton Seed,	290	Distributor, Manure: W. Tasker,	280
Locomotive, Messrs. Dodds' "Ysabel,"	150	Oil, Removal of the Viscous Constituent of,	50	Dog-cart, Adjustable: J. Begbie,	141
Locomotive on the London and North-Western Railway, M'Connell's Express,	180, 201	Ores, Mr. Stansbury on Machines for Pulverizing and Reducing Metalliferous,	242	Drain Pipes: G. G. Mackay,	137
Looms (Action for Infringement), "Continuous Check Strap" for Power,	292	Organs, Forster's Improvements in,	218	Dress and Ornamental Fastenings: J. G. Taylor,	168
Loom, Boyd's Noiseless Power,	280	Originators, The Claims of,	249	Dressing and Sizeing Machines: W. B. shall, jun ,	210
Loom for Narrow Fabrics, Lord Berriedale's Continuous-action,	85	Oscillations of the Steam Pressure Indicator, On the Occasional,	10, 40	Drill, Universal Ratchet: F. A. Calvert,	262
Lubricating Machinery, Johnson's Patent for,	166	Outlines of Geology, VI.,	65, 83	Duplex Pattern Fabrics: A. L. Knox,	161
Lubricating Shaft-bearings, Hick's Method of,	140	Ovens, Day's Truss for Supporting the Crowns of,	255	Evaporating and Concentrating Apparatus: G. J. Higginson,	258
Lubricator, Little's Self-Regulating,	149	Ovens, Slater's Biscuit,	120	Figured Fabrics: J. R. Cochrane,	164
Lubricator, Self-Acting,	239	Oysters,	153	Fire-arms, Breech-loading: J. Needham,	23
M				Fire-Grates: J. Finlay,	66
Macadamized Roads for Streets of Towns, Mr. J. Pigott Smith on,	285	P		Flax Gill, "D": W. K. Westly,	184
M'Dowall's High-speed Tension-Sawing Machine,	33	Paper for Preventing Forgery, Millet's Safety,	256	Flour Mills: J. Currie,	232
Madeira Grape Disease, The,	12	Paper-knotting Machine, Siebe's Cylindrical,	107	Flushing Apparatus: J. Adamson,	234
Magnet in the Useful Arts, The,	28	Paper Manufacture, The,	292	Forging Machine, Metal: J. H. Johnson (H. & G. H. Richards),	88
Manure, and Liquid Distributor, Spooner's Combined Seed,	279	Paper, Raw Materials for,	269	Furnace, Smokeless: J. L. Stevens,	43
Manure Distributor, Tasker's,	280	Parallelogram of Forces, The,	144	Furniture, Portable: A. D. Brown,	140
Manure from London Drainage, Dry,	148	Patent Office, Abuses in the United States,	196	Gas Burners: D. Laidlaw,	70
Marine Engineering on the Thames,	28	Patent Law Amendment Act, 1852,	252	Gas Burners: J. H. Johnson (M. Marmonty),	137
Marine Engines, Cavé's Compensating,	257	Patent Laws, American,	169	Gas-heating and Cooking Apparatus: W. F. Rae,	139
Marine Engines, Economical,	169	Patent Laws—Arts and Science—Harbours of Refuge—Geological Museum—Ordinance Survey of Scotland—Scotch Grievances,	147	Gas Lights applied to Ventilation: R. Brown,	91
Marine Engines for Screw-Propulsion, by Messrs. Scott, Sinclair, & Co., Greenock, Double-g geared,	1	Patent Laws, Defects in the Administration of the Present,	287	Glass Bottles and Jars: G. Wilson,	92
Marine Memoranda—Progress of Screw Propulsion, . 146, 197, 219, 246, 267,	289	Patent Laws, Reform in the American,	292	Guages, Steam and Water: G. Fife, M.D.,	91
Market, Manchester, Covering the Smithfield,	269	Patent Law, The New,	159	Houses, Portable: R. Walker,	162
Masts and Spars, M'Gavin's,	208	Patents for Inventions, The Law as to; in—		Illumination and Heating: A. M. Dix,	44
Mechanical Negligence, Curiosities of,	54	Austria, . 276		India-rubber Springs: W. C. Fuller and G. M. Knevit,	163
Mechanical Powers, The Simple Machines or,	37	Bavaria, . 203		Iron for Ship-building, Manufacture of: R. M'Gavin,	164
Mechanical Science during the past Year (1852-3), Mr. Fairbairn's Address on General Improvements in,	194	France, . 3		Lamps, Ship, Barrack, and Telegraph: M. Thomson,	113
Mechanic's Library, 14, 43, 66, 92, 112, 134, 160, 184, 206, 232, 258, 279		The German States of the Zollverein,	106	Locomotive Engines and Railway Axles: J. E. M'Connell,	23
Metals, as derived from Repeated Meltings, exhibiting the Maximum Point of		Prussia, . 131		Locomotive Engines: J. E. M'Connell,	186
		Russia, . 27		Locomotive Engines: Stubbs and Grylls,	22
		Spain, . 251		Lubricating Machinery: J. H. Johnson (M. Rapeand),	166
		United States of America,	39		
		Wurtemberg, . 183			

	PAGE		PAGE		PAGE
Lubricating Shaft Bearings: J. Hick, . . .	140	for the Exhibition of 1851, and Schools of Design, . . .	25	Rasping Dyewood, Mucklow's Machine for, . . .	188
Meters, Motive Power and: J. Kennedy, . . .	46	Phosphorus for Lucifer Matches, Amorphous, . . .	244	Rasping Machines, Self-acting Feeder for Beet-root, . . .	15
Motive Power: J. Anderson, . . .	165	Photographic Plates and Illustrations of Microscopic Objects in Natural History, Dr. Lankester on, . . .	193	Ratchet Brace and Self-Adjusting Screw-Key, . . .	284
Moulding in Metal: J. Bernard, . . .	259	Photometer, Dr. Price's New, . . .	215	Readers and Correspondents, To, 32, 56, 80, 104, 128, 152, 176, 200, 224, 248, 272, 296	
Moulding in Metal: J. W. Hoby and J. Kinniburgh, . . .	262	Photo-printing for Woven Goods, Smith's Chromatic, . . .	153	Reaper Improved, Hussey's American, . . .	96
Ovens, Biscuit: W. Slater, . . .	120	Phytoglyphy, Branson's, . . .	266	Reaping Machine, Atkins' Self-raking, . . .	8
Pencils, Ever-pointed: R. Pinkney, . . .	70	Pipes and Sheets by Hydrostatic Pressure, Weems' Manufacture of, . . .	108	Reaping Machinery, A. Crosskill on, . . .	194
Plough, Seed-sowing: P. Forbes, . . .	112	Plaiting and Braiding Machine, . . .	239	Reaping Machines, . . .	268
Power Loom, Noiseless: R. Boyd, . . .	280	Plaiting and Braiding Machine, Booth's, . . .	202	Refrigerator and Filter, Mills' Combined, . . .	256
Pyroligneous Acid Retorts: E. Mucklow, . . .	138	Platina Plating, Savard's Method of, . . .	257	REGISTERED DESIGNS:—	
Quarrying Slate: S. F. Cottam, . . .	70	Plough, Forbes' Seed-sowing, . . .	112	Carriage Spring, Compound: J. J. Catterson, . . .	143
Railway Brake: K. Heggie, . . .	115	Plough, Ritchie's Drill, . . .	157	Door-frames for Furnaces, Water-space: J. Illegius, . . .	24
Railway Joint Chair, Compound: J. Bell, . . .	235	Ploughs, Bentall's Self-registering Dynamometer for, . . .	219	Envelope, American: Waterlow & Sons, . . .	283
Railways: H. Greaves, . . .	119	Ploughs, Hill's Wrought-iron Skim or Paring, . . .	157	Gold-sifter: R. Lambert and T. Danby, . . .	48
Railways, Safety Apparatus for: R. Walker, . . .	211	Polisher, Baudet's Continuous Movement Metal, . . .	5	Hat, Eoliou: Flanagan & Co., . . .	122
Railway Wheels: T. C. Ryley and E. Evans, . . .	139	Potatoes Grown from Peels (Review), . . .	238	Ink-bottle: Blackwood & Co., . . .	212
Railways, Working: G. Stewart, . . .	168	Pouch, Advertiser, and Sample Bag, Bremner's Victoria, . . .	168	Library Desk, or Devonport: J. W. & T. Allen, . . .	212
Rasping Dyewood: E. Mucklow, . . .	188	Press, Hennah and Bourne's Duplex Embossing, . . .	149	Ornamental Watch-chain Connector: Whitmore and Winstone, . . .	213
Regulators, Steam Pressure: M. Baxter, . . .	67	Printing for Calico, Sandiford's Block, . . .	89	Pen, Reservoir, and Ink-bolder: R. Watkins, . . .	71
Roasting Jacks: T. Suttie, . . .	70	Printing for Woven Goods, Smith's Chromatic Photo, . . .	153	Pouch, Advertiser, and Sample Bag, Victoria Copper: S. Bremner, . . .	168
Rolling Wrought-iron Wheels: W. Johnson (J. S. Gwynne), . . .	184	Printing Machine, Glover's Polytint, . . .	255	Tent or Sleeping Cabin, Universal: H. Harrison, . . .	48
Rotatory Engine and Pump: T. Elliot, . . .	92	Prizes to be Given by the Society of Arts, List of Subjects for, . . .	243	Throttle Valve: Mills and Whittaker, . . .	93
Rotatory Engine: A. Parsey, . . .	283	Projectiles, Captain Norton's, . . .	28, 147, 177	Windows, Universal Safeguard for Cleaning: W. Duckworth, . . .	121
Rotatory Engines: C. Harford, . . .	135	Propeller, Sayer's Steam-ship, . . .	158	Registered Designs, Lists of, 32, 56, 80, 104, 128, 152, 176, 200, 224, 248, 272, 296	
Rotatory Steam-Engine: R. Barclay, . . .	186	Propulsion, Experiments in Screw, . . .	53, 100	Regulators, Baxter's Steam Pressure, . . .	67
Safety-valve, Self-acting: G. Humphrey, . . .	237	Propulsion, Progress of Screw, 146, 197, 219, 246, 267, 289		REVIEWS OF NEW BOOKS:—	
Screw-jacks, Traversing: G. England, . . .	236	Propulsion, Steam-ship, . . .	50	Atmospheric Impurity with Disease, On the Connection of. By H. M'Cormac, . . .	239
Sewers and Drains, Cleansing: R. Blades, Liverpool, . . .	114	Prussian-Blue, . . .	125	Decimal Coinage, The. By A. Millward, . . .	238
Shearing Machine, Metal: W. Williams, . . .	44	Pulverizer, Gray's Parallel Lever Subsoil, . . .	157	Draughtsman's Book of Industrial Design, The Practical. By Wm. Johnson, C.E., . . .	26
Sheathing Iron Ships: W. Seaton, . . .	140	Punching Machine of Duplex Action, Angle-Iron Shearing and, . . .	278	Electrical Illumination, A few Remarks on the Present State and Prospect of. By J. J. W. Watson, . . .	122
Shipbuilding Templates: A. Burns, . . .	282	Punching Plate-iron of Various Thicknesses, Table of Pressures Necessary for, . . .	183	Form in the Decorative Arts, An Attempt to Define the Principles which should determine. By M. Digby Wyatt, . . .	262
Ships and Boats: F. Lipscombe, . . .	282	Pyroligneous Acid Retorts, Mucklow's, . . .	138	Fuel, A Rudimentary Treatise on. By T. S. Prideaux, . . .	237
Ships' Bottoms, Preservation of: J. E. Cook, . . .	136	Q		Glass, On the Manufacture of. By G. Shaw, . . .	48
Shipbuilding, Timber: S. Schollick, . . .	260	Quadrature of the Circle; a Puzzle for Mathematicians, The, . . .	71	Gold-Diggers and Buyers, Australia the Ancient Ophir, Hiuts to intended. By G. F. Goble, . . .	264
Ships' Masts and Spars: R. M'Gavin, . . .	208	Quarrying Apparatus, Cottam's, . . .	70	Health Committee of the Borough of Liverpool on the Sewerage, Paving, Cleansing, and other Works, under the Sautory Act, Report to the. By J. Newlands, C.E., . . .	213
Shot, Hollow Expanding Cylindro-conoidal: J. Norton, . . .	90	Queen's College, Birmingham, . . .	53, 196	Home Resorts for Invalids, on the Climate of Guernsey. By S. E. Hoskins, M.D., F.R.S., . . .	263
Starcb, Manufacture of: E. Tucker, . . .	91	R		Industrial College for Artisans, Notes on the Organization of an. By T. Twinning, jun., . . .	263
Steam-Engines and Boilers: J. Harrison, . . .	16	Rails, Fish-joints for T, . . .	264	Industrial Drawing. By D. H. Mahan, LL.D., . . .	237
Steam-Engines: R. Burn, . . .	68	Railway Axle-box, Barrans', . . .	245	Moral Sanatory Economy. By H. M'Cormac, . . .	239
Stopcocks: H. Wilks, . . .	235	Railway Axle, French's, . . .	197	Museums, Libraries, and Picture Galleries. By J. W. Papworth, . . .	49
Sulphuric Acid, Alkalies, and their Salts: G. Robb, . . .	207, 208	Railway Brake, Heggie's, . . .	115	London Railway, Proposed. By P. M. Parsons, C.E., . . .	238
Tents: R. Lambert, . . .	47	Railway, Crosskill's Portable Farm, . . .	155	Patents, Summary of the Law of. By C. Wordsworth, . . .	144
Thermometers, Elastic Scales for: W. Mackenzie and G. Blair, . . .	68	Railway Carriage Axle-box, Adam's, . . .	150	Perspective Divested of all Difficulty, The Principles and Practice of. By R. Abbutt, F.R.A.S., . . .	169
Thrashing Machinery: Rev. A. Willison, . . .	134	Railway Danger Signals, Capt. Norton's, 245, 269		Perspective Explained, Theoretically and Practically, Duffin's First Principles of (Review), . . .	169
Tubes, Metallic: T. Potts and J. S. Cockings, . . .	143	Railway, Girard's Water Pressure, . . .	158	Perspective—Report of the Commissioners	
Turned Wooden Boxes: W. Kendall, . . .	141	Railway Joint Chair, Bell's Compound, . . .	235		
Velvet, Dressing and Finishing: F. B. Frith, . . .	167	Railway, Locomotive Expenses on the Eastern Counties, . . .	146		
Warp Delivery for Power-loom: C. Parker, . . .	210	Railway, Parsons' Proposed London (Review), . . .	238		
Washing Machine: J. Eldridge, . . .	68	Railway Point Key and Signal, Yorston's, . . .	134		
Water-pressure Engines: J. Sinclair, . . .	115	Railways, Greaves', . . .	119		
Weft Forks, Power-loom: Tayler and Slater, . . .	121	Railway Signal, Bouch's "Form and Colour," . . .	229		
Weft Forks, Power-loom: W. Stevenson, . . .	43	Railway Signal, Carrick's Self-acting, . . .	27		
Weft Winding Machine: P. Carmichael, . . .	120	Railway Sleeper, Day and Laylee's Semi-tubular Transverse, . . .	255		
Window Fastenings: Rev. M. Andrew, . . .	167	Railways, Rolling Stock on British, . . .	220		
Windows, Raising and Lowering: F. Russell, . . .	236	Railways, Safety on, . . .	51		
Window Sash Fastener: W. Westley and R. Bayliss, . . .	281	Railways, Stewart's System of Working, . . .	168		
Pedo-motive Carriage, . . .	191	Railways, Walker's Safety Apparatus for, 197, 211			
Pencils, Pinkney's Ever-pointed, . . .	70	Railway Trains, Mr. Fairbairn on the Retardation and Stoppage of, . . .	242		
Pen, Reservoir, and Inkholder, Watkins', . . .	71	Railway Wheels, Ryley and Evans', . . .	139		
Perspective, An Illustrated Definition of, . . .	95	Railway Working Expenses and Rolling Stock, . . .	28		

PAGE		PAGE		PAGE		
	Perspective, The Science of Vision or Natural. By A. Parsey,	169	Ship-building, Schollick's Improvements in Timber,	260	Steam Engines, Allechin's Agricultural,	113
	Potatoes Grown from Peels,	238	Ships and Boats, Lipscombe's,	282	Steam Engines and Boilers, Harrison's,	16
	Smoke Nuisance, Strictures on the Police Committee and the Inspector of,	123	Ships' Boats, Russell's Plan for Lowering,	256	Steam Engines, Burn's,	68
	Tables of Circles, Spheres, Square, &c. By Charles Todd,	96	Ships' Bottoms, Cook's Method of Preserving,	136	Steam Engines, Pipe and Ball Governor for,	150
	Water Scheme, Remonstrance of L. D. B. Gordon, Civil Engineer, against the adoption of Mr. Bateman's Plan for carrying out the Loch Katrine,	238	Ships for Tonnage, Mr. Henderson on the Speed and other Properties of Ocean Steamers, and on the Measurement of,	218, 240	Steam Engine, The Irish Engineering Company's Portable,	205
	Wheat with Profit, A Word in Season, or how to Grow,	238	Ships' Masts and Spars, M'Gavin's,	208	Steamer, Direct-action Inclined Engines of the "Duncan Hoyle,"	110
	Working Classes of Nassau, Letters on the Condition of the. By T. Twinning, jun,	263	Ships, Seaton's Method of Sheathing Iron,	140	Steamers, and on the Measurement of Ships for Tonnage, Mr. Henderson on the Speed and other Properties of Ocean,	218, 240
	Rifle, Gilby's Breech-charging and Self-priming,	226	Ships' Tables, Sayer's Equilibrated,	173	Steamers, British and American Lines of,	205
	Roasting Jacks, Suttie's,	70	Ships, Wymers's System of Boat Gear for,	278	Steamers, Reflecting Fog-Bells for,	240
	Root-grater, Baxter and Bushe's,	156	Shot, Norton's Hollow Expanding Cylindrical,	90	Steamers under Way, Stopping and Backing,	145
	Rotatory Engine and Pump, Elliot's,	92	Siemens' Improved Chronometric Governor,	227	Steam Hammer, Brown's,	133
	Rotatory Engine, Duplex Elliptic,	24	Signal, Bouch's "Form and Colour" Railway,	229	Steam Navigation in Hull, Oldham on the Rise, Progress, and present Position of,	216
	Rotatory Engine, Parsey's,	283	Signal, Carrick's Self-acting Railway,	27	Steam Pressure Governor,	123
	Rotatory Engines, Harford's,	135	Silk Dyed in the Worm,	28	Steam Pressure Regulators, Baxter's,	67
	Rotatory Steam Engine, Barclay's,	186	Simple Machines or Mechanical Powers, The,	37	Steam-ship Building under Cover,	101
	Rotatory Steam Engine, Nicole's,	256	Siphons, Lieut. Heathcote's Exhausting,	52	Steam-ship Propeller, Sayer's,	158
	Rotatory Valve Engine and its Advantages, Locking on Locking and Cook's,	216	Siphons, Self-exhausting,	148	Steam-ship Propulsion,	50
	Royal Academy, The Exhibition of the,	58	Siphons, Exhausting,	73	Steel, Heath v. Smith—Action for Infringement—Manufacture of,	197
	Royal Institution, The,	275	Slate, Fireproof Laths of,	284	Stoll's Patent,	124
	S		Sledge for Carriages, Snow,	264	Stopcock, Frost and Co.'s Eccentric or Compensating,	87
	Safety Lamp, Dr. Glover on a New,	286	Slips, Scott's Continuous-action Screw Purchase for,	258	Stopcocks, Wilks',	255
	Safety Valve, Humphrey's Self-acting,	237	Sluice Valves for Hydraulic Works, Roe's,	291	Stoves, Beuret and Dertelle's Domestic,	159
	Safety Valve Lever, Cawood and Sunter's Ferrule,	73	Sluice Valves, Jennings',	27	Stuffing-box Gland Adjustment, Barlow's,	264
	Safety Valve, Water Gauge, and Alarm, Wheeler's Combined,	94	Small Diameter Steam Boiler, Holcroft and Hoyle's,	278	Submarine Telegraph, The English and Belgian,	77
	Sailing Vessels, Brodie's Improvements in,	215	Smelting by Electricity, Pichon's Method of,	257	Sugar-Pans, Charcoal Kilns and Vacuum,	63
	Salt, Soda from,	292	Smelting Furnaces, On the Application of the Blast to,	71	Sugar-Works, Irish Beet,	28
	Samnelson's Rotatory Digger,	111	Smoke, A. Fraser on the Consumption of,	266	Sulphuric Acid, Alkalies, and their Salts, Robb's Patents for,	207, 208
	Sawing Machine, M'Dowall's High Speed Tension,	33	Smoke Nuisance, Strictures on the Conduct of the Police Committee and the Inspector of (Review),	123	Sun-fish Oil,	153
	Sawing Machine, Worssam's Deal,	230	Soap as a Vehicle of Art,	290	Sunk Vessels by Buoyant Gas, Raising,	220
	School of Mines in Cornwall, Government,	290	SOCIETIES, PROCEEDINGS OF SCIENTIFIC:—		Suspension Bridge over the Clyde at Glasgow,	62
	Scientific Observations at Sea,	76	British Association at Hull, The, 170, 192,	215	T	
	Scotch Grievances:—Patent Laws—Arts and Science—Harbours of Refuge—Geological Museum—Ordnance Survey in Scotland,	147	Institution of Civil Engineers, 27, 51, 73, 98, 124, 145, 218, 240, 266,	285	Tables of Circles, Spheres, Squares, &c., Todd's (Review),	96
	Scott, Sinclair, & Co., Greenock, Double-gear Marine Engines for Screw Propulsion, by Messrs.,	1	Institution of Mechanical Engineers, 27, 97,	172, 242	Telegraph Company in Ireland, The Electric,	150
	Scrap Iron Forging, Stenson's Improvements in,	219	Liverpool Polytechnic Society,	267	Telegraphic Longitude,	289
	Screw Jacks, England's Traversing,	236	Marlborough House, Department of Science and Art,	267	Telegraph, The English and Belgian Submarine,	77
	Screw-Key, Ratchet Brace and Self-Adjusting,	284	Royal Institution,	242, 275, 288	Telescopes, Mr. Sollitt on the Composition and Figuring of the Specula for Reflecting,	192
	Screw Propeller, Hunt's Governor for,	277	Royal Scottish Society of Arts, 27, 52, 74,	145, 267	Telescope, Varley's Graphic,	215
	Screw Propeller, The lateral Action of the,	94	Royal Society,	98, 242	Templates, Burns' Shipbuilding,	282
	Screw Propulsion, by Messrs. Scott, Sinclair, & Co., Greenock, Double-gear Marine Engines for,	1	Scientific Department of the Board of Trade, Museum of Practical Geology,	267	Template for Iron Shipbuilders,	213
	Screw Propulsion, Experiments in,	53, 100	Society for the Encouragement of National Industry in France,	161	Tent, or Sleeping Cabin, Harrison's Universal,	48
	Screw Propulsion, Marine Memoranda, Progress of,	146, 197, 219, 246, 267,	Society of Arts,	28, 51, 145, 242, 266,	Tents, Lambert's,	47
	Screw Purchase for Slips, Scott's Continuous-action,	258	Soda from Salt,	292	Thermometers, Mackenzie and Blair's Elastic Scales for,	68
	Screw Steamer, The "Brilliant" Madeira Packet Brig, as an Auxiliary,	52	Soda Water, Lamplough's Consolidated,	174	Thermostat, for Regulating Temperature and Ventilation, Ward on a New,	217
	Scythe, Boyd's Double-action Self-adjusting,	157	Sounding, Deep Sea,	220, 264	Thrashing Machine, Moffitt's American,	203
	Seed, Manure, and Liquid Distributor, Spooner's Combined,	279	Soundings, and Errors therein from Strata of Currents, with Suggestions for their Investigations; Dr. Scoresby on Deep Sea,	216	Thrashing Machinery, Willison's,	130, 134
	Shearing and Punching Machine of Duplex Action, Angle-Iron,	278	Sowing Plough, Forbes' Seed,	112	Throttle-valve, Mills and Whittaker's,	93
	Sewers and Drains, Blades' Method of Cleansing,	114	Spring, Catterson's Compound Carriage,	143	Tiles, Borric's Cellular Roofing,	220
	Sewers, Compound,	25	Spring Protectors, Carriage,	191	Timber Tree, A New,	290
	Sewing Machine, Wickersham's American,	181	Springs, Coleman's India-rubber,	97	Time Ball for the Clyde, Electric,	293
	Shaping Machine, Renshaw's Engineer's,	230	Springs, Fuller and Knevitt's India-rubber,	163	Tools, Renshaw's Patent Composite Cutting,	60
	Shearing Machine, Williams' Metal,	44	Stamping Machines at Somersset House, Hill's Newspaper,	2	Tools, Softening Cast-steel for,	214
	Sheathing Iron Ships, Seaton's Method of,	140	Stamping Vessels, Salt and Lloyd's Process for,	97	Tube Manufacture—Bower v. Hodges <i>et al.</i> —Action for Infringement,	148
	Sheaves, Brown's Block,	69	Starch, Tucker's Manufacture of,	91	Tubes, Potts and Cockings' Metallic,	143
	Shipbuilding Templates, Burns',	282	Steam and Ether Engine, Rennie on the Combined,	217	Tunnelling and Excavating Machine, Talbot's,	244
			Steam Boilers, Hill's Mode of Preventing Deposit in,	101	Turbine, M'Adam's (Belfast),	13
			Steam Boilers, Prevention of the Deposit in,	123	Turned Wooden Boxes, Kendall's,	141
			Steam Engine, Barclay's Rotatory,	186	Turnip-cutter, Williamson's Double-action,	204
			Steam Engine, Manifold and Lowndes' Combined Expansion,	231	Turn-tables, Self-moving,	93
			Steam Engine, Nicole's Rotatory,	256	U	
					Umbrellas (Infringement), Holland's Patent,	245
					V	
					Vacuum Sugar-Pans, Charcoal Kilns and,	63
					Velocipede, or Pedo-motive Carriage,	191
					Velvet, Frith's Machine for Dressing and Finishing,	167
					Ventilation, Brown's Gas-lights applied to,	91
					Viscous Constituent of Oil, Removal of the,	50

W		PAGE			PAGE			PAGE
Warp-delivery for Power Looms, Parker's, .		210	Gordon, Civil Engineer, against their adopting Mr. Bateman's Plan for carrying out the Loch Katrine (Review), .		238	Winding-motion for Ring-and-traveller Spinning Frames, .		28
Washing for Clothes, Steam, .		149	Weaving, Stop-motion for Floats in, .		246	Window Fastenings, Andrew's, .		167
Washing Machine, Eldridge's Domestic, .		68	Weft-forks, Stevenson's Power Loom, .		43	Window Sash Fastener, Westley and Bayliss', .		281
Watch Chain Connector, Whitmore and Winstone's Ornamental, .		213	Weft-forks, Tayler and Slater's Power Loom, .		121	Windows, Duckworth's Universal Safeguard for Cleaning, .		121
Water Gauge and Alarm, Wheeler's Combined Safety Valve, .		94	Weft-winding Machines, Carmichael's, .		120	Windows, Russell's Method of Raising and Lowering, .		236
Water Meter, Hartin's Cylinder, .		132	Weighing Machines and Weighing Cranes, James's, .		42	Windows, The Mechanism of Carriage, .		283
Water Meter, Taylor's Improved, .		242	Wheat with Profit, A Word in Season, or how to Grow (Review), .		238	Winter Garden, Dublin, .		290
Water Power—M'Adam's (Belfast) Turbine, The Economy of, .		13	Wheelbarrow, Captain Wilson on a New, .		218	Wollaston, Thomson's Biographical Account of Dr., .		98
Water-pressure Engines, Sinclair's, .		115	Wheels, Davis' Carriages and, .		166	Working Classes of Nassau, Twining's Letters on the Condition of the (Review), .		263
Water-pressure Railway, Girard's, .		158	Wheels, Johnson's (Gwynne's) Method of Rolling Wrought-iron, .		184	Worssam's Deal Sawing Machine, .		230
Water Scheme—To the Honourable the Lord Provost, the Magistrates and Town Council, and to the Water Rate-payers of the City of Glasgow, the Respectful Remonstrance of Lewis D. E.			Windguard, Feret's Spherical, .		101			
			Winding Engine erected at Mr. Astley's Colliery, Dukinfield, Mr. Fairbairn on a New, .		242	Y		
						Yarn, Stevenson's Clearing Apparatus for, .		207

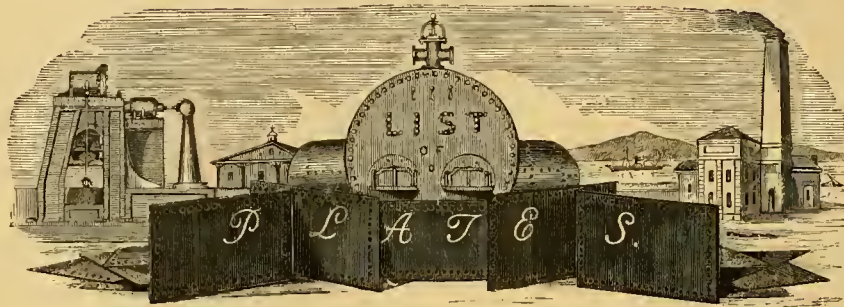

AND BINDER'S DIRECTIONS.

Plate	To face	Page	Plate	To face	Page
CXX. Scott, Sinclair, & Co.'s Double-Geared Marine Engines, .		1	CXXXIII. Scott, Sinclair, & Co.'s Engines of the <i>Duncan Hoyle</i> Steamer, .		110
CXXI. " " " " " " " "		ib.	CXXXIV. Bellhouse's Twin Steam-Boiler, .		131
CXXII. Practical Draughtsman, .		20.	CXXXV. Hartin's Water-Meter, .		132
CXXIII. M'Dowall's High-Speed Tension Sawing-Machine, .		33	CXXXVI. Sayer's Steam-Ship Propeller, .		158
CXXIV. James' Weighing-Machine, .		42	CXXXVII. Glasson's Oval Tubular Boiler, .		160
CXXV. Dr. Watson's Electric Lamp, .		57	CXXXVIII. London and North-Western Express Locomotive, .		180
CXXVI. Scott, Sinclair, & Co.'s Charcoal Kilns, .		63	CXXXIX. " " " " " "		ib.
CXXVII. " " " " " "		ib.	CXL. " " " " " "		201
CXXVIII. Scott, Sinclair, & Co.'s Vacuum Sugar-Pans, .		64	CXLI. Worssam's Deal-Sawing Machine, .		230
CXXIX. Jones' Refining and Puddling Furnaces, .		81	CXLII. Renshaw's Engineer's Shaping-Machine, .		231
CXXX. " " " " " "		82	CXLIII. Scott's Continuous-Action Screw-Purchase for Slips, .		258
CXXXI. Fearn's Metallic Ornamentation, .		86	CXLIV. Holcroft and Hoyle's Small Diameter Steam-Boiler, .		278
CXXXII. Bower's Gas Retorts and Combined Gas Apparatus, .		105	CXLV. " " " " " "		ib.

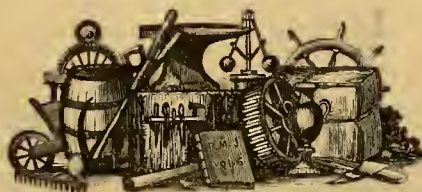

DOUBLE-GEARED MARINE ENGINES.

MESSRS SCOTT, SINCLAIR & CO GREENOCK.

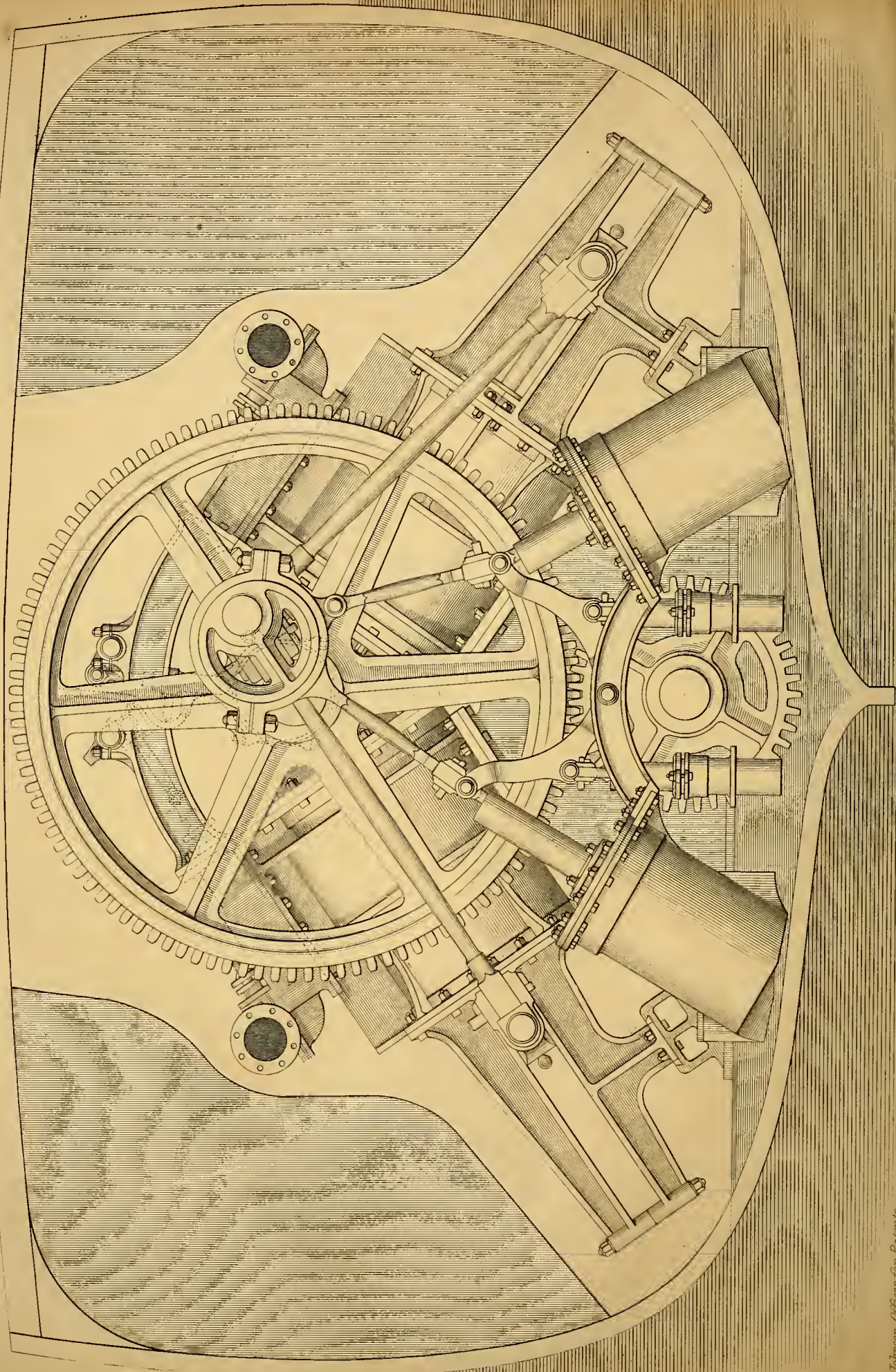

DOUBLE-GEARED MARINE ENGINES.

MESSRS SCOTT, SINCLAIR & CO GREENOCK.

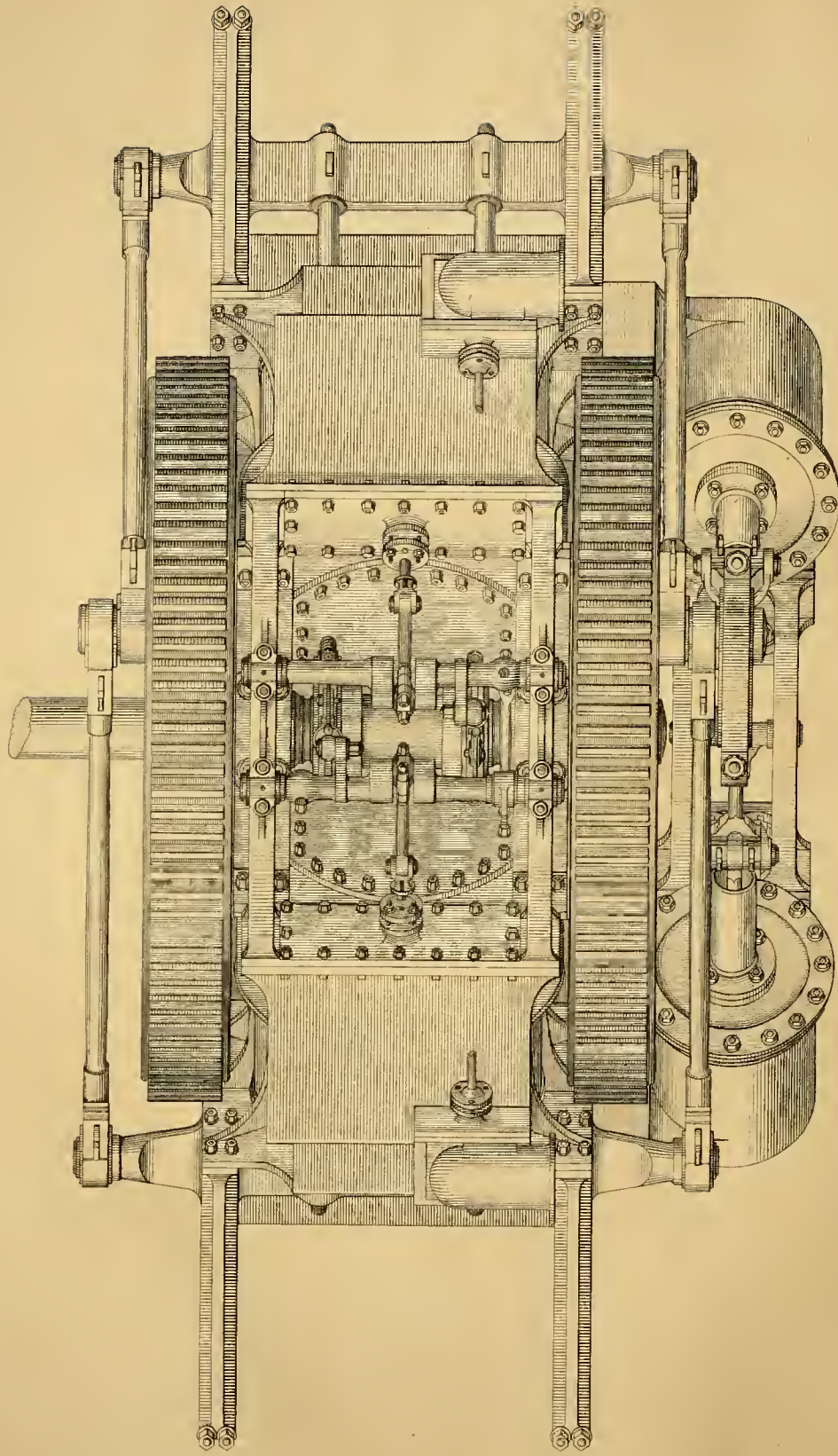

12 9 6 3 0
 Inches Feet

THE
PRACTICAL MECHANIC'S
JOURNAL.

DOUBLE-GEARED MARINE ENGINES FOR SCREW PROPULSION, BY MESSRS. SCOTT, SINCLAIR, & CO., GREENOCK.

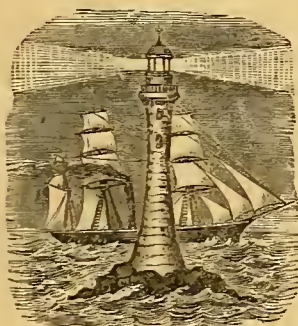

(Illustrated by Plates 120 and 121.)

THE engines which we have introduced in our two leading plates of the present volume, under the distinctive title of "double-geared," are, perhaps, the most compact specimens of their class in existence, for the space actually occupied by them, fore and aft the ship, is but 12 feet 6 inches, although the cylinders are each 52 inches diameter, with a power of 250 horses, and the ship is 260 feet in length. But in assigning the engines this high character, we do so, not because the makers have contrived to cram a complex mass of machinery into an unduly limited space, but because, whilst the grand feature of compactness has been thus well kept in view and secured, the whole details have been combined under a convenient, workmanlike, and symmetrical form. It is essentially necessary to observe this part carefully, because no statement as to an extraordinary condensation of parts can be said to be worth anything, if such arrangement has been arrived at only by impairing the conveniences of attendance and efficiency of action, as not infrequently exemplified in marine engines of an earlier date. Here, every weight is well balanced; all the working parts are clear and open; and the combined whole is stable, firm, and well bound together. The general character of the engines must be immediately obvious, even to the ordinary observer, from our two views. That in plate 120 is a transverse section of the ship, showing the engines in complete external front elevation. Plate 121 contains a corresponding plan of the engines. The cylinders are 52 inches diameter, and 3 feet 9 inches stroke, placed diagonally athwart the ship, and at right angles to each other, whilst the piston-rods project through the lower covers, to allow of long return connecting-rods. Each cylinder has two piston-rods for greater steadiness, their outer ends in each case being keyed into a cross-head fitted at each end with slide-locks, for working in a pair of inclined open guide-frames bolted to the bottom cylinder cover, and supported beneath by projecting bracket-pieces, recessed and bolted down upon pedestal-pieces on the engine sole-plate. From each end of this cross-head, immediately outside the guide-frame, a plain straight connecting-rod of round section, passes up to actuate the main first-motion shaft. The upper ends of these connecting-rods are jointed to

side studs, or crank pins, fast in two opposite arms of a pair of large spur-wheels, which give motion to the screw-shaft by means of a pair of corresponding spur-pinions, fast on the shaft beneath a single pin in each wheel, answering for the two opposite connecting-rods on the same side of the engines. The main spur-wheels are 11 feet 5½ inches diameter, with 108 teeth of 4-inch pitch, and 14 inches in breadth on the face. They are keyed on the extremities of a common shaft, which is conveniently placed in the angular space formed by the two ends of the inverted steam cylinders, being carried in a pair of pedestals cast with angular bracket-pieces to bolt down upon the cylinders. The plan, plate 121, shows that the wheels are equally compactly placed, one on each side the cylinders and the general mass of machinery, and just filling up the space inside the connecting-rods. The pinions on the screw-shaft are 4 feet 6 inches diameter, so that the ratio between the screw and the engine's rate is 2½ to 1. By this arrangement, each piston is directly coupled to both of the large wheels, and the increased length of the cross-heads which the plan involves, is counterbalanced by the effect of the double piston-rods, for by this division of the pressure, the cross-strain leverage is proportionately diminished. The system of duplex gearing also insures a good, substantial, and well-balanced connection of the first-motion shaft with the screw-shaft. The air-pumps are both situated on one side of the engines, and are worked from the connecting-rod stud of the spur-wheel on that side, the pump cylinders being bolted at their lower ends by their foot branches to the sole-plate, whilst their upper ends are connected together by a couple of arched cross-pieces. They are thus well bolted together and to the main framing, their intermediate connecting brackets answering to carry the stud centres of a pair of bent levers for working the bilge and feed pumps. The whole of the pumps are constructed on the trunk principle, of which class Mr. Humphries' engines of the *Dartford* are so well known as the earliest type.

As the throw of the main driving studs would be too great for the purposes of the air-pumps, it is very ingeniously reduced by means of an eccentric set upon the stud, so as to bring the real working centre nearer to the centre line of the first-motion shaft. One of the connecting-rods for working the pumps is formed in one piece, with the eccentric ring, and the other is jointed to the ring on the opposite side; both rods descending to joint eyes on the upper ends of links which are again connected by bottom joints, in the recesses of the plunger trunks of the pumps. The same intermediate joints of the lower ends of the connecting-rods also afford the means of connection with the upper ends of the bent levers of the bilge and feed pumps, which levers thus serve the purpose of radius bars for the air-pump rods. The links for working the plunger trunks of the bilge and feed pumps are jointed

nearly at the middle of the bent levers, so as to give the required short stroke, the pumps themselves being set vertically, one on each side the screw-shaft, on the sole-plate.

The cylinder valves are combinations of the four-ported class, so successfully introduced on the Clyde by Mr. Thomas Wingate, and the equilibrium valve. With this arrangement, the engines are handled with very great facility, and a very free exhaust is obtained. They are actuated by a pair of eccentrics on the main first-motion shaft, rods from which pass upwards to short levers, on a pair of parallel rocking shafts, working in end hearings overhead. These hearings are carried upon a pair of parallel arched frame-pieces, stretching across between the two valve-chests, so that they thus hind the upper ends of the cylinders. The rocking shafts are cranked at their centres, and have short connecting-rods jointed on to the crank-pins, and extending right and left to their respective valve-spindles. The steam enters the valve-chests on each side, through the elbow branches opening into stop or expansion valve-chests at the lower corners of the valve-casings; and the exhaust steam passes off to the condenser by passages round both sides of the cylinders. The condenser is entirely within the engine, beneath the cylinders. It answers, indeed, as the supporting pedestal for the cylinders, which are bolted down upon it.

The gear for handling the engines is more clearly shown in the plan, plate 121, a rocking lever being fitted to work loose on one of the parallel rocking shafts, to allow of both engines being started from the same platform.

The engines are intended for an iron screw steamer, of 1190 tons, o. m., now building by Messrs. Scott, Sinclair, & Co., to run between Glasgow and New York. This ship will shortly be upon her station, when we shall duly note and report upon her performances.

HILL'S NEWSPAPER STAMPING MACHINES AT SOMERSET HOUSE.

The ugly faint red impression which stands at the corner of every newspaper sheet, as a record of the legal penny payment into the "stamp and tax" department of our "inland revenue," involves a much larger amount of industrial exertion in the subordinate grades of Government employment, than the ordinary newspaper reader generally imagines. The gigantic power of the press of this country has necessarily grown up under, or rather hand-in-hand with, the circulation of an enormous aggregation of individual impressions. The *Times* alone, with its 30,000 or 40,000 daily copies, creates an immense demand for stamping labour; and if we stop a moment to consider the sum of the daily and weekly printed contributions of only a few of the other leading papers of the time, we shall see that the State stamping business is on the grandest scale, and that busy industry must be hard at work in the stamping factories of Somerset House, Edinburgh, Manchester, and Dublin. The weight of paper stamped daily at Somerset House, ranges from some fifteen to twenty tons.

But as respects the modes of performing the work, the staid pace of a Government Department is somewhat liable to be outrun by the stirring movements of the busy world outside. In these essentially utilitarian days, so fraught with "the trading spirit and the thirst for wealth," fresh enterprise is continually bursting forth; new expedients are continually being tried, and every growth of mechanical contrivance is continually being tested and adopted, as its merits command, for the securing further economical advantages, and higher and more perfect results. Machinery driven by steam-power has long been employed in the stamping department at Somerset House—Sir W. Congreve's compound printing machines, for impressing the medicine and hank-note stamps—and Mr. E. Hill's embossing machines for impressing the medallion postage stamps; but, until the last few months, all the newspaper stamps throughout the kingdom have been impressed by unaided manual labour. It is true that some attempts have been made in earlier days to adapt mechanical appliances to this purpose; and they failed, it is said, not so much from any mechanical difficulty in making the actual impression, as from difficulty in handling the paper so as to bring the unwieldy sheets under the operation of the ma-

chine with sufficient rapidity, as well as removing them out of the way when stamped. In other words, the intrinsic action of the stamping movement was less in fault than the feeding and discharge processes. It is our business now to show how these difficulties have been removed by the mechanical skill of Mr. Edwin Hill, of the stamp department, a gentleman whose name is associated with many other manufacturing contrivances of modern times. That gentleman, assisted by his son, Mr. Ormond Hill, has been successful in getting to work, in Somerset House, a set of machines, of which we now present the engravings. In these views, fig. 1 is an external side elevation of the apparatus, and fig. 2 is a corresponding vertical section.

The principal parts of the machine are, first, a small hammer-shaped arm, *A*, to one end of which the die, *B*, is attached, so as to form the head of the hammer. The other end of this arm has pivots, like the trunnions of a cannon—the whole in shape much resembling an old-fashioned forge-hammer. When in action, this hammer-shaped arm turns upon its trunnions, first into the horizontal position *backward*, so as to present the

Fig. 1.

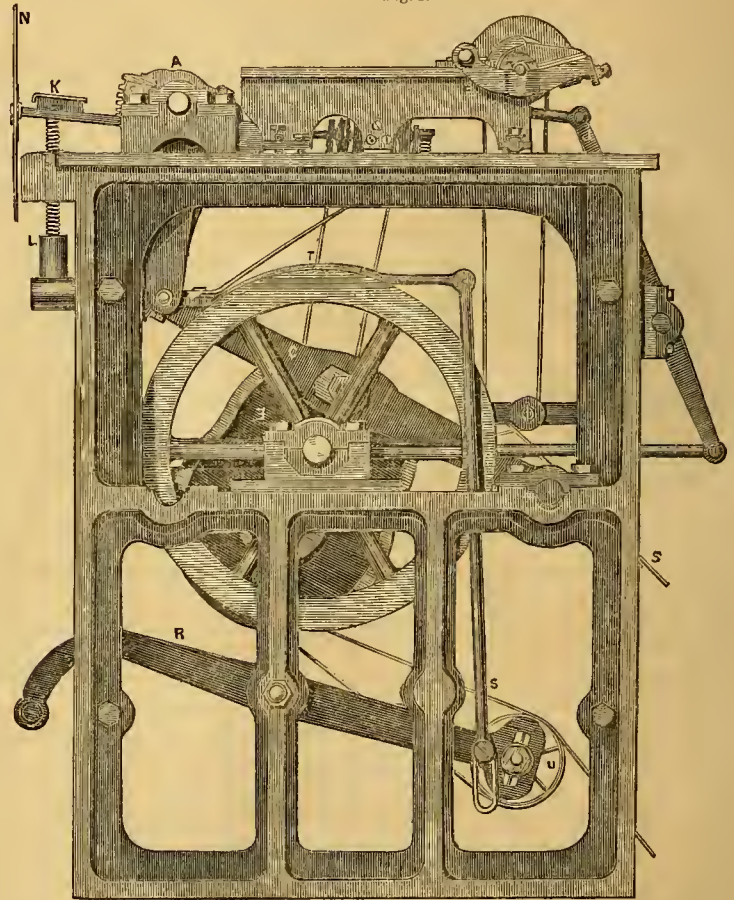

face of the die upwards, to receive the ink. It next turns completely over upon its trunnions into the horizontal position *forward*, that is, into the position of a forge-hammer when it has fallen; and this last movement brings the inked face of the die down upon the paper, and impresses the stamp.

In order to give the arm, *A*, these backward and forward motions, a segmental-toothed wheel is attached to it. This wheel gears with the teeth of the toothed sector or arched head of the long lever, *C*, which lever, carrying the tumbler indicated by the dotted circle, *D*, is thrown up and down alternately by the action of the cam, *E*.

The inking apparatus, *F*, has but little peculiarity. Its distributing table, *G*, is circular, upon Congreve's plan; but it is moved when required, not by a ratchet, but by a slack band, that being found a simpler, cheaper, and more effective plan. So long as the inking rollers continue in contact with the table it remains at rest, for the slight friction of the slack band is overpowered by the adhesion of the ink; but the moment the inking rollers, by passing out of contact, set the table at liberty, the slack band partly turns the table, and thereby presents a

new path for the rollers to travel over. The sliding frame, u, which carries the inking rollers, i, is worked backwards and forwards by the lever, j, which derives its motion from cranks behind.

The small table, κ, receives the corners of the sheets of paper, one after another, for stamping. This table is a portion of an arm, l, which has the same centre of motion as the arm, a, in order to preserve parallelism between the die and the table, notwithstanding that the position of the table may require adjustment. It is covered with vulcanized caoutchouc, and is supported by pillars, l, resting upon a strong spring, m, made to give way in case of any thick substance endangering the machine by getting into the place of the paper.

The beater, x, is a four-armed wheel, placed just clear of the outside of the small table, κ. Its arms are mere haws or loops of light whalebone. Its purpose is to rid the machine of the stamped sheet, by pushing its corner down under the table the instant it has received the stamp. For this purpose, the moment the impression is completed, the beater wheel makes a quarter turn, bringing its upper arm down upon the paper, a little outside of the edge of the small table, κ, and thereby striking the corner of the sheet off the table, to make room for the corner of the next sheet. Whilst the impression is being given, the beater stands still, and its looped whalebone arm, which has just struck down the stamped sheet, now helps to support the sheet that is next presented for stamping. This beater is one of the most essential parts of the machine,

Fig. 2.

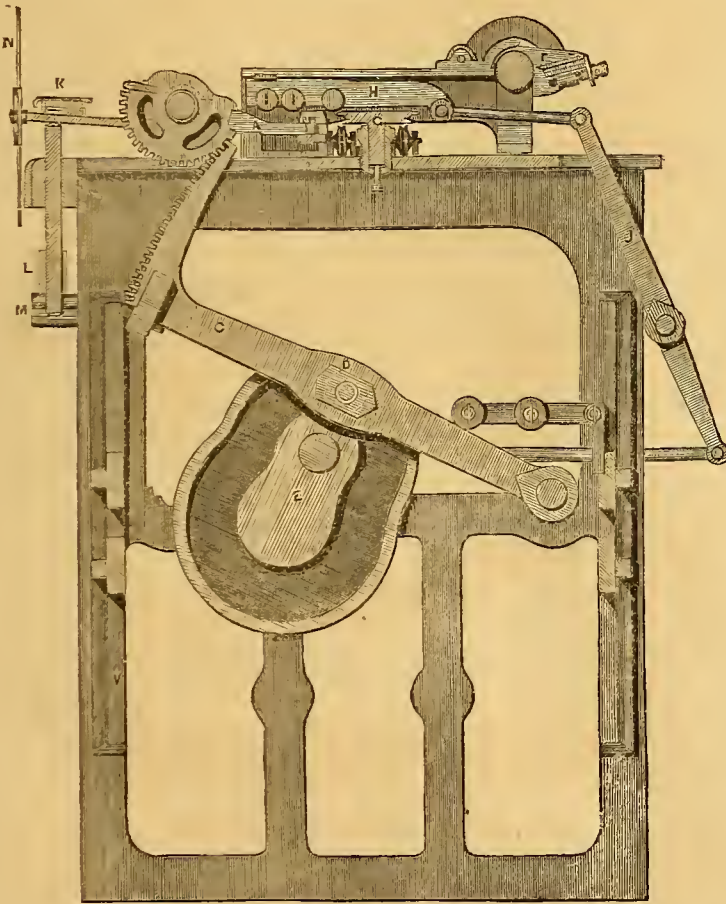

inasmuch as it effects the instant removal of the paper when stamped; an indispensable part of the operation, the means of accomplishing which, however, were by no means obvious. It is worked by a ratchet, which derives its motion from the die arm through the medium of a pair of bevel wheels.

A treadle is attached for starting and stopping the machine, which, when pushed down by the boy's foot, depresses one end of the lever, u; the other end of which lever, by lifting the break, r, releases the strap, s, and the lever at the same time forces up against this strap the tightening pulley, v. The treadle is so hung as to be moveable sideways, as well as up and down. When depressed, it is also forced by the foot into the lower notch of the upright board, v, which, being fixed upon the floor,

holds down the treadle. When the machine has to be stopped, the boy with his foot pushes the treadle sideways out of the lower notch, upon which it at once rises, being counterbalanced by the elasticity of the strap, and the weight of the break and its rod added to that of the tightening pulley. The break falls upon the strap, which also is at the same moment slackened by the depression of the tightening pulley; the machine therefore stops, and the treadle lodges in the upper notch of the board, v, which secures it from accidental depression, as otherwise the machine might be set in motion dangerously, when intended to be at rest. As the machine has to be started and stopped incessantly, it is quite necessary that the apparatus for this purpose should be more than usually efficient in its operation.

The speed of the machine being considerable, and its principal movements either reciprocating or intermittent, or both, great care has been necessary to prevent jolting. The application of the crank secures the inking apparatus a smooth motion; and the curves of the cam, by which the tumbler wheel is alternately lifted and depressed, are so traced as to give to the tumbler, whenever it is moved, a motion similar to one swing of a pendulum, and therefore free from jolting. For, to set a pendulum in motion, it is merely drawn to one side by the finger and thumb, and then released, and its motion, in swinging across to the other side, which gradually accelerates to the midway point, then gradually diminishes to nothing, so that the pendulum may be caught on the other side just as its motion is completely exhausted; thus the pendulum neither receives any blow at starting, nor gives any blow in stopping; and as in this machine, the long lever, the hammer, and the beater, all derive their motion from the tumbler, their motion is similarly free from jolts, both at the beginning and the ending of each traverse.

The speed is 100 strokes per minute; which, were it not for the incessant stoppings, would give 6000 impressions per hour; the actual performance, however, is a little more than 4000 impressions per hour for each machine. Each machine is attended by two boys, one of whom feeds, whilst the other opens the reams, and prepares the paper for the machine, and after stamping, removes it, and ties it up again in reams.

These machines are now in regular use at Somerset House, where they obviously add very much to the despatch of business in the Stamp Office, and materially increase the facilities for wielding that powerful arm of public opinion—the newspaper.

THE FRENCH LAW RELATING TO PATENTS FOR INVENTIONS,

WITH NOTES, BY JAMES JOHNSON OF THE MIDDLE TEMPLE.

Letters patent for inventions (Brevets d'Invention) are regulated in France by a law bearing date the 5th July, 1844, the material parts of which are as follow:—

1. Every new discovery or invention, in any branch of industry, confers upon its author, under the conditions and for the time hereafter mentioned, the exclusive right of working the same for his own benefit. Such right is constituted by the documents issued by government, denominated *brevets d'invention*.

3. The following cannot be patented:—(1.) Pharmaceutical compounds, or medicines of any kind, these being governed by special laws and regulations, principally by a decree of the 18th August, 1810; (2.) schemes and projects of credit and finance.

4. The duration of patents shall be five, ten, or fifteen years: the payment in respect of a patent for five years shall be 500 francs (£20. 16s. 8d.); for a patent for ten years, 1000 francs; and a patent for fifteen years, 1500 francs. These sums shall be paid by yearly instalments of 100 francs, and the patent will expire if default shall be made in payment of any one instalment.

2. The following will be deemed new discoveries or inventions:—The invention of new industrial products, the invention of new means, or the new application of known means, for the attainment of an industrial result or product.

5. Persons desirous of obtaining a patent shall deposit, under seal, at the office of the secretary of the prefecture in the department where he is domiciled, or in any other department where he may elect to be domiciled—(1.) His petition to the minister of agriculture and commerce; (2.) a description of the discovery, invention, or application forming the subject of the proposed patent; (3.) the drawings and specimens requisite to the due comprehension of the description; and, (4.) a memorandum of the documents deposited.

6. The petition shall be restricted to a single principal object,* with the necessary details and its proposed applications. It shall mention the duration which the applicant desires for the patent, within the limits fixed by article 4; and shall contain no restrictions, conditions, or reservations. It shall give a title, comprehending a summary and precise designation of the subject of the invention. The description must not be written in a foreign language, and must not contain alterations or interlineations. Words erased must be counted and verified; the pages and references marked with the applicant's initials. It must not refer to other weights or measures than those set forth in the table annexed to the law of the 4th July, 1837, viz., the kilogramme, the mètre, and the litre. The drawings must be traced in ink, and according to scale. A duplicate of the description and the drawings must be annexed to the petition. All the documents shall be signed by the applicant, or by his attorney, whose authority must remain annexed to the petition.

7. No documents will be received except on production of a receipt proving payment of a sum of 100 francs (£4. 3s. 4), on account of the tax on the patent. A *procès-verbal*, prepared without charge by the secretary-general of the prefecture on a special registry, and signed by the applicant, shall evidence every deposit, and declare the day and hour of the receipt of the documents. A transcript of the *procès-verbal* shall be delivered to the depositor on payment of the expense of the stamp.

8. The time of the patent shall begin to run from the day the documents are deposited, according to article 5.

9. Immediately after the registration of the petition, and within five days from the date of the deposit, the *préfets* shall transmit the documents, under the seal of the inventor, to the minister of agriculture and commerce, annexing thereto a certified copy of the *procès-verbal* of deposit, the receipt proving payment of the tax, and, if there have been one, the authority mentioned in article 6.

10. When the documents shall have been received by the minister, they shall proceed to the opening, to the registration of the petitions, and to the preparation of the patents, according to the order in which the petitions were received.

11. The patents which shall have been applied for in due form, shall be delivered out without previous examination, at the risk and peril of the applicants, and without government guarantee either as to the reality, the novelty, or the merit of the invention, or as to the fidelity or accuracy of the description. A decree of the minister, declaring the formality of the petition, shall be delivered to the applicant, and shall constitute the patent. To this decree shall be annexed the certified duplicate of the description and the drawings mentioned in article 6, after their conformity with the originals shall have been recognised and established in case of need.

The first copy shall be delivered free of charge; upon every other copy applied for by the patentee or his agent, shall be imposed a tax of 25 francs. The expense of a drawing, in case there be one, shall be defrayed by the person requiring it.

12. Every application in which the formalities prescribed by sections 2 and 3 of article 5, and by article 6, have not been attended to, shall be rejected. Half of the sum paid shall be forfeited to the treasury, but credit will be given to the applicant for the whole of it, if he again makes application within three months, reckoning from the date of the notification of the rejection of his previous petition.

13. When the petition for a patent is rejected by reason of the application falling under article 3, the tax shall be refunded.

14. A royal ordinance, inserted in the *Bulletin des Lois*, shall announce every three months the patents issued.

15. The duration of patents can only be prolonged by a law.

16. The patentee, or the persons entitled to the patent, shall have the right, during the currency of the patent, to make alterations, additions, or improvements in the invention, by complying, in lodging the petition, with the requisitions of articles 5, 6, and 7. These alterations, additions, or improvements, shall be proved by certificates issued in the same form as the original patent, and shall have, from the dates of the petition and grant respectively, the same effect as the original patent, with which they will expire. Every petition for a certificate of addition shall be subjected to a tax of 20 francs. The certificates of addition obtained by any one person entitled under the patent, shall accrue to the benefit of all.

17. A patentee who, in respect of an alteration, addition, or improvement, desires to take out a principal patent for five, ten, or fifteen years, in place of a certificate of addition expiring with the original patent, must comply with the requisitions of articles 5, 6, and 7, and pay the tax mentioned in article 4.

18. Only the patentee, and those claiming under him, acting as aforesaid, can, during a year, obtain a valid patent for an alteration, improvement, or addition to the invention forming the subject of the original patent; nevertheless, every person wishing to obtain a patent for an alteration, improvement, or addition to a discovery already patented, may, in the course of the said year, make a formal application to the minister of agriculture and commerce, which shall be transmitted to him, and shall remain deposited under seal. At the expiration of the year, the seal shall be broken and the patent issued; but the original patentee shall always have the preference in respect of alterations, improvements, and additions, for which he himself shall, during the year, have demanded a certificate of addition or a patent.

19. Whoever shall have obtained a patent for a discovery, invention, or application, connected with the subject of another patent, shall have no right to make use of the invention previously patented; and, on the other hand, the proprietor of an original patent shall not make use of an invention subsequently patented.

20. A patentee may assign the whole or a part of his property under a patent. The entire or partial assignment of a patent, whether as a gift or for valuable consideration, can only be made by a notarial act, and after payment of the whole tax mentioned in article 4. No assignment shall be valid with respect to third parties, until after registration in the office of the secretary of the prefecture in the department in which the deed shall have been made. The registration of assignments, and all other acts effecting a change of property, shall be made on production and deposit of an authentic abstract of the deed of assignment or change. A copy of every *procès-verbal* of registration, accompanied by the abstract of the deed above-mentioned, shall be transmitted by the *préfets* to the minister of agriculture and commerce in five days from the date of the *procès-verbal*.

21. There shall be kept, at the office of the minister of agriculture and commerce, a register, in which shall be entered the assignments, &c., of each patent; and every three months a royal ordinance shall announce, in the form prescribed by article 14, the assignments, &c., registered during the preceding three months.

22. The assignees of a patent, and the persons who shall have derived from a patentee, or those claiming under him, the right of using the discovery or invention, shall have the full benefit of certificates of addition subsequently obtained by the patentee, or those claiming under him. On the other hand, the patentee, or those claiming under him, shall have the benefit of the certificates of addition subsequently obtained by the assignees. Every person having a right to the benefit of certificates of addition, may obtain a copy from the minister of agriculture and commerce, on payment of a fee of 20 francs.

23. The descriptions, drawings, specimens, and models of patents issued, shall remain deposited, until the expiration of the patents, with the minister of agriculture and commerce, where they may be inspected by any one, free of charge. Any person may obtain, at his own expense, copies of the said descriptions and drawings, according to the forms laid down in the rule framed under article 50.

24. After payment of the second annual instalment, the descriptions and drawings shall be published textually or by abstracts. At the beginning of each year shall also be published a list of the titles of patents issued in the course of the preceding year.

25. The descriptions, drawings, and list published in pursuance of the last article, shall be deposited in the office of the minister of agriculture and commerce, and of the secretary of the prefecture of each department, where they may be inspected free of charge.

26. At the expiration of the patents, the original descriptions and drawings shall be deposited at the *Couservatoire Royal des Arts et Métiers*.

27. Foreigners may obtain patents in France.

28. The formalities and conditions prescribed by the present law shall be applicable to patents demanded or issued under the last article.

29. The author of a discovery or invention already patented in a foreign country, may obtain a patent in France: but the duration of this patent shall not extend beyond that of the patent previously obtained abroad.†

30. Patents shall be null and of no effect in the following cases, viz., (1.) If the discovery, invention, or application is not new; (2.) if the discovery, invention, or application is not patentable under article 3; (3.) if they refer to principles, methods, systems, discoveries, and theoretical or purely scientific conceptions, the industrial applications of which are not shown; (4.) if the discovery, invention, or application is contrary to the order, safety, morals, or laws of the kingdom—without prejudice, in this case and that of the last section, to the penalties which may be

* It has been the practice in England, until lately, to allow several distinct inventions to be included in one patent; but the law officers of the Crown have recently notified their wish to discontinue this practice.

† A similar provision has been inserted in the Patent Law Amendment Act, 1852.

incurred by reason of a making or sale of prohibited objects; (5.) if the title under which the patent has been applied for, fraudulently indicates something which is not the true subject-matter of the invention; (6.) if the description annexed to the patent is insufficient for carrying the invention into effect; or, if it does completely and fairly state the real methods adopted by the inventor, (7.) if the patent has been obtained contrary to article 18. Certificates of alterations, improvements, or additions, not made dependent upon the original patent, shall also be null and of no effect.*

31. No discovery will be held new, which, previous to the date of the deposit of the petition, shall have received publicity in France, or in a foreign country, sufficient to enable any one to execute it.

32. A patentee will be deprived of his rights under the following circumstances:—(1.) If he should fail to pay the annual payment before the commencement of each year of the term of the patent; (2.) if he shall not put his invention or discovery into execution within two years from the date of the signature of the patent, or if he shall cease for the space of two consecutive years to work the patent—unless, in either case, he can justify his inaction; (3.) if he introduces into France objects made in a foreign country, similar to those protected by his own patent. Models of machines, the introduction of which is authorized by the minister of agriculture and commerce in the case contemplated by article 29, are excepted from the operation of the preceding paragraph.

33. Whoever, in his trade inscriptions, advertisements, prospectuses, marks, or stamps, shall assume the title of patentee, without possessing a patent issued according to law, or after the expiration of a patent; † or who, being a patentee, shall describe himself as patentee, or refer to his patent, without adding thereto the words—“*sans garantie du gouvernement*,” (without the guarantee of government,) shall be liable to a penalty of from 50 to 1000 francs. In case of a repetition of the offence, the penalty may be doubled.

The remaining articles of this law relate to proceedings for repealing patents, and against persons infringing. The only articles it seems necessary to give at length are—

40. All attacks upon the rights of a patentee, either by the manufacture of the things patented, or by the use of patented processes, constitute the offence of infringement. The offence will be punished by a penalty of from 100 to 2000 francs.

41. Those who shall have knowingly secreted, sold, or exposed to sale, ‡ or brought into the French territory, one or more imitations of patented articles, shall be liable in the same manner as a person guilty of infringement.

43. In case of a repetition of the offence, the person guilty of infringement shall be liable to an imprisonment of from one to six months, over and above the penalty mentioned in articles 40 and 41. A repetition will be established when, within five years, a previous conviction can be proved for any offence against the present law. Imprisonment for from one to six months may be inflicted, if the infringer be a workman or servant who has worked in the factory or business of the patentee; or if the infringer, having joined a workman or servant of the patentee, obtained a knowledge from him of the patented processes.

BAUDET'S CONTINUOUS MOVEMENT METAL POLISHER.

M. Armand Baudet, a jeweller of Paris, has lately effected a considerable improvement upon the ordinary barrel-polishing machine, as used for polishing small articles of metal on the mutual attrition principle. Hitherto the barrel has been fitted with, and made to revolve on, spindles coinciding with the axial or centre line of the barrel. M. Baudet retains the barrel in exactly the same form, but set diagonally as to its spindles—so that the axis of revolution makes an angle with that of the barrel. The new arrangement is represented in our engraving, in perspective elevation. The two spindles, *ab*, are attached at opposite edges of the barrel ends, and the whole is supported in hearings, *cc'*, resting on the frame, *b*, as in the ordinary machines—being fitted with fast and loose pulleys for driving, and also a fly-wheel to equalize the motion.

The articles to be polished, as jewellery, or other small objects in metal, are introduced through an opening, *d*, in the position occupied by the bung-hole of an ordinary barrel, a species of bung being, of course, provided to close the opening.

M. Baudet recommends that, for jewellery, the barrel should not be

above one-third filled, and that the speed should be proportionate to the diameter of the barrel. With this arrangement, the articles under operation will partake of a kind of duplex or differential movement, their own weight causing them always to descend to that part of the barrel which is lowest. This causes a traverse from end to end, each end being alternately raised and lowered in the course of a revolution. This, combined with the simple rotatory movement, must necessarily turn over the articles in all conceivable directions.

M. Baudet's experience shows that this machine will produce the

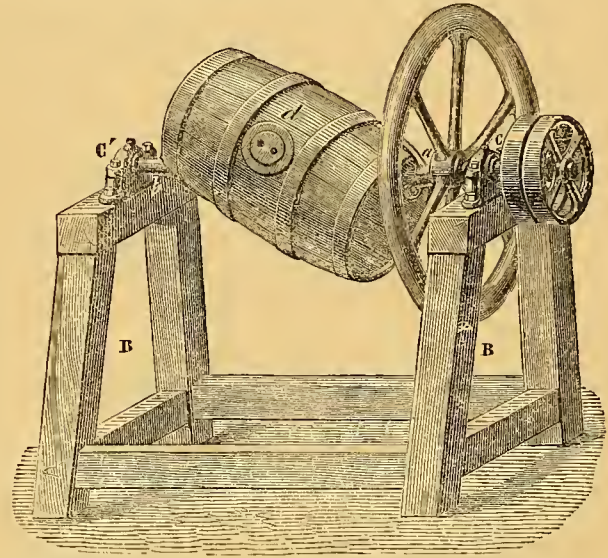

intended polish in one-fifth or one-sixth of the time required by the common method—a very beautiful polish, moreover, being obtained, in some cases, as excellent as that produced by burnishing. This system is obviously applicable to many of the industrial arts, being capable of variation in size and form to suit many particular purposes.

SOME ACCOUNT OF THE MARQUIS OF WORCESTER'S CENTURY OF INVENTIONS.

I.

Two hundred years ago, wanting only a twelvemonth, a nobleman, high among his order, and distinguished by his share in the vicissitudes of the time, having long diversified political activity with scientific pursuits, sat down to task his recollection for an outline of researches and points attained to—his former notes on such matters having perished or been mislaid—and so doing, built himself a monument which has maintained, or even increased, its interest, when illustrious birth, fortune and misfortune, and even political activity, would only have made him a cipher on the pages of the historian.

The century, or hundred, selected out of matters “by him tried and perfected,” seems to have been drawn up in 1655, and published a few years after, being then addressed, in the first place, to the king, (Charles the Second,) and, secondly, to the Houses of Parliament, in a very prolix and ceremonious preface or introduction; but that the noble author's character is otherwise well reputed, it would suffer with the perusal of such profuse protestations of patriotic ardour. Will they only select one of his proposals, he and his possessions are devoted to its execution. Recompense is quite foreign to his views, although his wings are clipped by his losses (in the civil war). No. “I cannot be satisfied,” he says, “in serving my king and country, if it should cost them anything.” All he desires in this life is, to pay his debts, put by a maintenance, and bestow all else on the service of the parliament, which is shown in some lengthy similes to be the steward of the sovereign—a metaphor that would be improved by a reversal. They have but to give the word,

“For certainly you'll find me breathless to expire,
Before my hands grow weary, or my legs do tire.”

But as it was quite open to his lordship to write letters in cipher, or introduce improvements in art and manufacture, without parliamentary permission, we must presume that all this rigmarole is to be taken by the rule of contraries. There is no such excessive modesty in regard of the commodity thus offered to the nation:—“The treasures buried under these heads—both for war, peace, and pleasure—being inexhaustible,” but any sort of *quid pro quo* is altogether repudiated.

* This article comprises, in a few clear words, the rules which, in our English law, have to be laboriously gathered from many volumes. With the French law before us, it would not seem a very difficult performance to digest into a short intelligible code, the whole of our statute and case law relating to this subject.

† This provision seems to be but an act of justice towards the public, and might, we think, be beneficially introduced into our law.

‡ It was decided, in the case of *Minter v. Williams*, (Welster's Pat. Cases, 137,) that the mere exposure to sale of a patented article is not an infringement.

The collection is entitled, "A Century of Names and Scantlings," the former being briefly enumerated in one list, and the outlines stated in a second, which, however, with a few exceptions, vouchsafe the end and object only, not the means to be employed; and shrouding even the former in blank, if not enigmatic terms, so as to present a startling and paradoxical result. No systematic order is adopted; several similar projects seem frequently to have suggested one another to the writer's memory, an important item or two being, however, reserved to give weight to the conclusion.

To go through the list *seriatim* is inexpedient, many of them admitting of an indefinite number of solutions equally consistent with the vagueness of the terms announced. Taking them, however, in groups, irrespective of the order of their occurrence, we shall see the character of objects then deemed worth pursuing, and the success then attained to, or believed so to be.

It may here be noticed, that a second edition, varying slightly, was issued by the author, and it has since been several times printed—once in the 'Harleian Miscellany,' for instance, and also in the 'Gentleman's Magazine,' 1748. The latter, and an edition by Partington, offer solutions of some articles, but not exhibiting special ingenuity or research. The latter volume contains, however, some curious biographical material. In reference to one of the Marquis' subjects, 'Stuart's Anecdotes of the Steam Engine' is worth consulting; and the curious will there make some acquaintance, by the aid of a poor engraving, with his lordship's exterior—a set of features far from handsome, and with an expression suggestive of little besides good nature and respectability: eyes, however, rather wide apart, are a pre-natal indication of engineering ability.

The series is headed by five schemes for writing in cipher, or cryptography, as it has been called—an art which has lost much of its dignity as an accomplishment of the statesman, and an instrument of warlike or diplomatic contest, owing, in some measure, to a heightened moral feeling, which—in private society, at the post-office, and, to some extent, abroad—makes that secret which lies within a seal. A recent instance, however, of its employment will be found in 'Napier's Peninsular War,' in the notes to which a French dispatch will be found, and its successful rendering by the lady of the author, aided, however, by knowing subsequent events, and working at it deliberately; and it is obvious, that to baffle an enemy's penetration for a time is comparative efficiency. Those who, for recreation, desire to estimate the practicability of Worcester's asserted inventions in this line, are referred to 'Rees' Cyclopædia,' and, generally speaking, to works somewhat antiquated, the subject being as old at least as the Greek seytale, a strip of characters legible only when wound round and upon a particular staff, while sympathetic inks of various colours, invisible till washed with a reagent, were familiar to the Romans.

No. 10 is the converse of the writings last under discussion—one that every one can read—the "universal character," on which so much ingenuity has been spent. The term, however, has been carelessly applied to two matters considerably different: 1st, An alphabet representing, by a complete set of analogies, the *sounds* composing speech; as, loudness by the size of the marks, pitch by their position, articulation by a slight picture of the forms assumed by vocal organs; and, 2dly, An alphabet of ideas spoken of the elements combined by mental association. The difficulty of this latter is illustrated by the failure of Leibnitz, and though the scope of the former is definable, no degree of superiority will, it seems, induce men to adopt a change. None of the improved music notations have obtained so much as a hearing, nor have the phonotypists "carried" their mere *corrections* of the common alphabetic characters. In the language, however, of science, where new sets of ideas arise, there is scope for the construction of symbols. As to the vehicle of common intercourse, the Anglo-Saxon tongue seems disposed to make itself universal by driving back its rivals. Some other proposals for ciphers occur, as by various media, by writing in the dark (which, with us, assumes the useful form of an alphabet for the blind), notation by smell, taste, and touch, by the crossing of weavers' threads, and a knotted string (the mode of ancient Mexico), all sufficiently credible in fact, however dubious in value.

No. 80 suggests that some of the uses of such inventions were exceptionable. It is a mode of knotting a glove-fringe to record cards thrown away at primero, as to which Mr. Partington thinks it "scarcely too much to aver, that taking an undue advantage of an opponent savours very much of foul play, if not of absolute cheating." To borrow the address on the Exhibition consignment from Italy, Mr. P.'s is "a ease posed with softness," nor would his lordship's ghost probably impugn it for being too unqualified. However, something similar, though less complete in the mode—viz., of holding the cards—is authorized by Hoyle, and the morality is perhaps unaltered by keeping account out of

or inside the head. At the following article to this, we must, however, throw up the defence. Honest ingenuity is not occupied in devising a dice-box to retain at pleasure the (four) true dice, and throw out (four) loaded ones, and the box having, moreover, transparent holes (a usual precaution, it seems, among gentlemen of the good old times). As notions then were, however, the Marquis avows the paternity, and presents his offspring to parliament and at court. Secret communication includes also most species of telegraph, two of which (one for night use) are projected; but it is not worth while to conjecture what means were intended, out of a host which have been proposed. For all stationary lines, electricity has superseded them; and for extempore or moveable telegraphing, no general plan can be laid down. A rule sooner or later will cease to be a secret, and new combinations are needful for security. Among such modes, one distinction is important—the writing or signal may be plainly blank and obscure, signifying nothing, or it may bear a pretended meaning and conceal a real one. The superiority of the latter is obvious; an attempt at deciphering an intercepted message may fail, but it is still safer when nothing seems to need deciphering. A mere blank sheet of paper would excite suspicion of invisible fluid, but this would be covered by writing a pretended message in common ink. Dissimulation, says Lord Bacon, is but the skirts of secrecy. It is matter for speculation, that while so much of the ingenuity is bestowed on secret marks, none is given to an end that has employed some of the most refined art and artists in later times—the security from forging, involving accurate and multiplied reproduction of the model. Coupled with the preceding, are modes of secret transmission and conveyance. An old mode was to write on leaf-metal, and roll it up into an earring, or on a bladder to be blown all over the inside of a flask. Silkworm's eggs, it will be remembered, were smuggled into Europe in a cane, and the same story is told of the introduction of saffron. In the 'Century,' we have suggestions of hollow spoons, knives, and forks; a comb, too, is so applied (thanks, we may suppose, to the clumsy make of old specimens, though a scroll wrapped round a pin would be lodged in a narrow apartment). Minuteness, however, is by no means the only security from detection. Papers have been sewn between the messenger's boots, and the famous letter from Charles the First, intercepted by Cromwell, would have travelled safely in a saddle but for a treacherous hint.

The Irishman who dropped a kettle overboard "had not lost it, for he knew where it was," but to look up a thing usually secures it almost as much as its secretion. We have several suggestions hereupon; thus, a single small key locking numerous bolts; the smallness of the key may perhaps mean a substitution of a screw for a lever, and several bolts, shooting in parallel lines, are sometimes in the present day connected by a frame. No. 72 is a scutehon, to vary a lock 10,000,000 times—an anticipation, apparently, of the ring-letter padlock; a brilliant invention, yet achieving little popularity, perhaps because involving the chance of inaccessibility to the owner, who forgets his password, and finds his property so well secured that he cannot get at it himself—for the combinations of only six letters allow a range of more words than are likely to be thought of in any ordinary space of time. Moreover, the scutehon will not allow its fidelity to be even tampered with, but will sound an alarm; and, however speedy be the tempter's retreat, it will set a mark on him, but, it seems, using him tenderly, as Walton did the frog. This must mean marking his hand by nitric acid, for instance, a stain as indelible for the time as Duncan's blood seemed to his murderer. The modern detector-locks record the fact of an attempt, leaving the author thereof to conjecture; but Worcester's lock, even if overpowered, still watches the depredation, notes down the number of clandestine visits, and, to a farthing, the amount of the abstractions. Partington suggests a cash-holder, releasing and counting only one coin at a time; but if so, it would be needful to have one receptacle for each species of coin; and, besides, one would rather learn from a "Chubb" that the thief did not, because he could not, take any at all. No. 74, a door changing its way of opening with facility, from outwards to inwards, or *vice versa*, or by halves. A Mr. Hawkins is said to have had some such plan in 1796, and chaise doors to have worked in the first alternative. (See 'Gent's Mag.' 1748.) No. 79 locks at one turn all such drawers of a cabinet as have been opened, which would be easy or otherwise according to the situation of the drawers. They are said to unlock separately; but it would seem an improvement to deprive them of independence in this respect, equally with the reverse operation. So much for modes of fortifying, now for those of assaulting a lock. Thus, we have an engine, portable, to open any door with "only one crack." Query, however, if this means one uttered by the door. If not, this may be a kind of petard, a contrivance already known; but a violent explosion seems not what is intended, the crack rather indicates the crisis in wedging or screwing. Gunpowder, however, and the weapons that employ

it, form a strong section of the list. There had been too much chance to study them—too much experience of their effect. One, No. 44, is a pistol in the innocent guise of a key, the barrel-end being (visibly) no thicker than paper. The next item begins harmlessly, "a most concealed tinder-box;" it will give you a light without thrusting your hand from out the bedclothes. The ulterior result is, that you are provided with a pistol. This seems but on the defensive, and unjustly reproached as "a good idea"—for a highwayman. As privacy is so much dwelt upon, we should expect to meet with the air-gun—a very ancient notion—but apparently not worked on by Lord Worcester. Nor do we meet with any ingennities of secret defence, the quilting of James the First, or chain mail of Cromwell, used against the assassin when external armour was disappearing. By No. 8 we are to point a cannon as surely by night as by day, and not by observation previously taken. The article follows a night telegraph, but is far less conceivable. Within certain limits, concave mirrors would throw a ray of light, and still more with applications as in our own times of electricity.

Col. Colt was not more desirous of quick firing than our author; but his schemes, though more varied than the Colonel's, were less fortunate in obtaining adoption. Partington writing, when "revolver" was no household word or a practical weapon, could only suggest that Worcester's charges were successively rammed down the barrel to a series of touch-holes, the locks sliding back a notch after firing the outer charge: if this be practicable, it may have been among the suggestions, and are offered, all different, and applying to weapons of all magnitude. One actually fired a cannon, in royal presence, twenty times in six minutes, and so safely, that butter lay unmelted in the breach. As to this case, the solution stated above is excluded by a statement, that the charges to follow were six feet away from the gun. No idea then existed of converting steam to deeds of mischief—a column of bullets, 240 per minute—though, for experiment, the Marquis had burst a cannon by steam power. We find a memorandum of a plan outstripping that in the 'Century,' for ordnance charged and discharged simultaneously, twenty times in two minutes, threefold faster than the Marquis's, and approved by the Royal Society, to whom it was shown by Mr. Ellis in 1747. There are also two places for firing at one touch any number of pieces—not lying together, *a la Fieschi*, but as the broadside of a ship. An electric spark would now effect this; and before that medium was familiar, one Bouchon fired 100 rockets on such terms with experimental success. Other missile propellers occur; a cross-bow for two bolts is no great matter; nor would a way of throwing bombasses, and 100 lb. weight bullets, even to the distance of a quarter of a mile, excite much interest at Woolwich. True, it is by a spring, and without sound, to make an agreeable surprise to the besieged; but in such matters self-shelter is subordinate to destruction; and ever since Isaiah, the battle of the warrior has been with confused noise. The mechanical elasticity, as of twisted ropes, in the "Scorpion," can never compete with that released by chemical disunion. No. 9 is a cunning device, a little article to be taken on board the enemy, "*tanquam aliud agens*," as if you had nothing particular in your pocket; winding it up, you will attach it judiciously to the ship's timbers, at the time set to it, a week afterwards, it will infallibly sink the ship. A percussion shell and a watch are quite capable of doing this. How far strangers have the *entrée* of a ship's hold, and in war time, too, is best known to the nautical mind. What follows is still more Warnerian. With an eye probably to the point just hinted, he will show how to dive and fix it—ay, from a quarter of a mile off. What Fulton's submersible ship might have done to the bottoms of our navy is conjectural; certain "carcasses," however, were actually made in the late war; they were to float to their destination, hide their time, and explode; one of them did drift and burst on the beach, and killed some innocent bystanders. No light is thrown by the *Gentleman's Magazine* on any of the preceding matters—the writer opining that there were ways enough of killing men already. It may be a relief, however, to learn that there is a preventative (No. 11) for the last engine—it is not to come home to ourselves to fasten on our ships, even by night; to this effect internal partitions have been suggested, so that a single leak should not fill the ship; but the language rather intimates that the evil is to be kept at a distance. In truth, to guess the precautions against it we must know better what it is. No. 12 is allied to the last, and renders any number of shot hulled immaterial, be they between wind and water; or if a whole plank goes, a quarter of an hour is to see everything reinstated. This "quarter of an hour" is a favourite period of his lordship's, and perhaps amounts to any little while. In the matter of shot-holes under water, a few minutes would seem long enough; a sheet of oakum has been used for this purpose externally—the influx of the fluid pressing it into the aperture; a more singular suggestion is that of a piece of beef so placed. No. 13 is a man-trap, or men-trap, to kill or catch by a false deck an entire boarding party as soon as fairly on board. Partington

sees here a double deck, with just room between for gunpowder; but in case of blowing up, "making prisoners" seems out of the question, and the article provides for making all fair and square again to receive a second deputation. No. 16, a bomb-proof sailing castle, carrying a force of 1000 men; but the bomb-proof qualities of the ships at Gibraltar availed their occupants little, nor in our days is a vessel capable of ten hundred men an invention; but though we cut our ships in half at the dockyard, we don't expect each portion to sail off on its own account. The Marquis's vessel was thus tripartite; but it is not obvious what would be gained. No. 28, a bridge for a half mile of water, carried about by six horses, must be interpreted of a swimming bridge—a pontoon; that is, in truth, no bridge at all, but a float. There are other military matters offering no noticeable pretensions, and some better suited, perhaps, for unwarlike enterprise. No. 49 is an instrument "in the way of a tobacco tongs," (meaning probably the jointed zigzags known as lazy tongs—*i. e.* tongs for the lazy,) whereby to scale a wall, and if expedient scale hack again. This combination of levers has been also applied to fire-escapes; and we have a fellow-contrivance, *viz.*, a very portable ladder to be drawn from a pocket, and fixed up to 100 feet above. Perhaps the actual ladder was of rope, and hoisted by jointed rods, or by a kite, as once at Pompey's Pillar; and whatever his modes, the Marquis would have been an invaluable member of a corps of burglars.

Inventive art in its childhood is addicted to toy contrivance. Bishop Wilkin, not long before, had concocted a volume of such amusements; and this is appropriate to the preliminary exercises of inventiveness. Still it was hardly reasonable to submit to the parliament, even of a merry monarch, a bird to fly any way, and for as long as desired, varying the performance by hovering and chirping. A commentator says that Merlin did as much, only that his bird was on wires. It is to be feared that the Marquis also had wires, by a mental reservation. However, his flying successes were not confined to feathered bipeds; under his management a boy 10 years old achieved that desideratum—Wilkins, the great authority on this point, having only proved that men ought to fly. *Nota bene*, however, that the flying took place in a barn. No. 92 is a hobbyhorse to ride at the ring, possessing points of great superiority, but which we can now ill appreciate. No. 88 is a talking head, a notion ascribed to Roger Bacon, but really dating back to a time when physical knowledge was the slave of priestly jugglers. Of more innocent deceptions, the invisible girl may be referred to as a better illustration of this item than the mechanical flute-player which has been cited—it was an acoustic trick, not an articulating machine.

Practical jokes were to be expected: an innocent looking chair, clasping with iron arms the person who trusts himself into it—a piece of furniture mentioned by Evelyn among the *notabilia* at the Borghese Palace; but it reminds one of a less sportive device in some old feudal castle—a chair which descended a shaft, bearing the victim from the hanquet to a dungeon. No. 85, "an untoothsome pear;" the first bite shoots out a set of bolts, that it can no more be extracted from the mouth than a reel from a bottle. One would wish it like the ball of Phalaris, to be tried on its inventor. No. 47 is a ball, which being thrown into water exhibits the true time by the depth of immersion; those who possess a watch not requiring a pond, &c., will hardly set much store by this affair—the use of fluid for chronometry is a retrograde movement. A fountain working like an hour-glass, and that can be turned by a child—a favourite expression of the writer's to denote great facility—will afford cascades in variety: snow, ice, and thunder, with (somewhat incongruously) the chirping and singing of birds. On the latter head some hints will be found in Hero of Alexandria—whether the snow and ice were frozen water, and if so, how frozen, we cannot say. No. 22 also seems a piece of hydrotechy—a popular garden feature with our ancestors, and many devices in which are probably lost; a floating garden, however, which is described with all sorts of erections, involves no special novelty—requiring only, a critic says, a very roomy barge.

No. 56 is a contribution to the annals of perpetual-motion seeking: a wheel, with 16 weights so attached to the circumference, that while in revolution, as each is about to descend, it hangs out further from the centre than all those then ascending; the consequence he, with civil exultation, begs the reader to judge. Should science, however, be wanting, practical proof is at hand. The Marquis appeals to actual trial before his late Majesty and suite, upon apparatus of ample magnitude erected in the Tower, the lieutenant whereof being a producible testimony. The most noted of such efforts, as described by Gravesande, revolved for two months, when the maker in a real or pretended pet destroyed it; we are not informed how Worcester's perpetuity came to an end. It may be noticed that the problem is sometimes evaded by applying a current of terrestrial magnetism, which certainly will be as perpetual as the apparatus that receives it; besides this, by reducing friction a force may be greatly economised—thus a spinning-top has retained its impulse

for a remarkable time. The fallacy of our present scheme was demonstrated by Desaguliers, and again some twenty years back in the *Mechanic's Magazine*; but such ideas are not easily "laid," and the plan will probably have more revivals.

Another machine to "numerate and subtract, and that whether sums

or fractions," would probably in those days be deemed more improbable than the last; it was probably a simple species of a class not unknown in ancient times, but of which a living compatriot has given by far the finest example.

ATKINS' SELF-RAKING REAPING MACHINE.

Fig. 1.

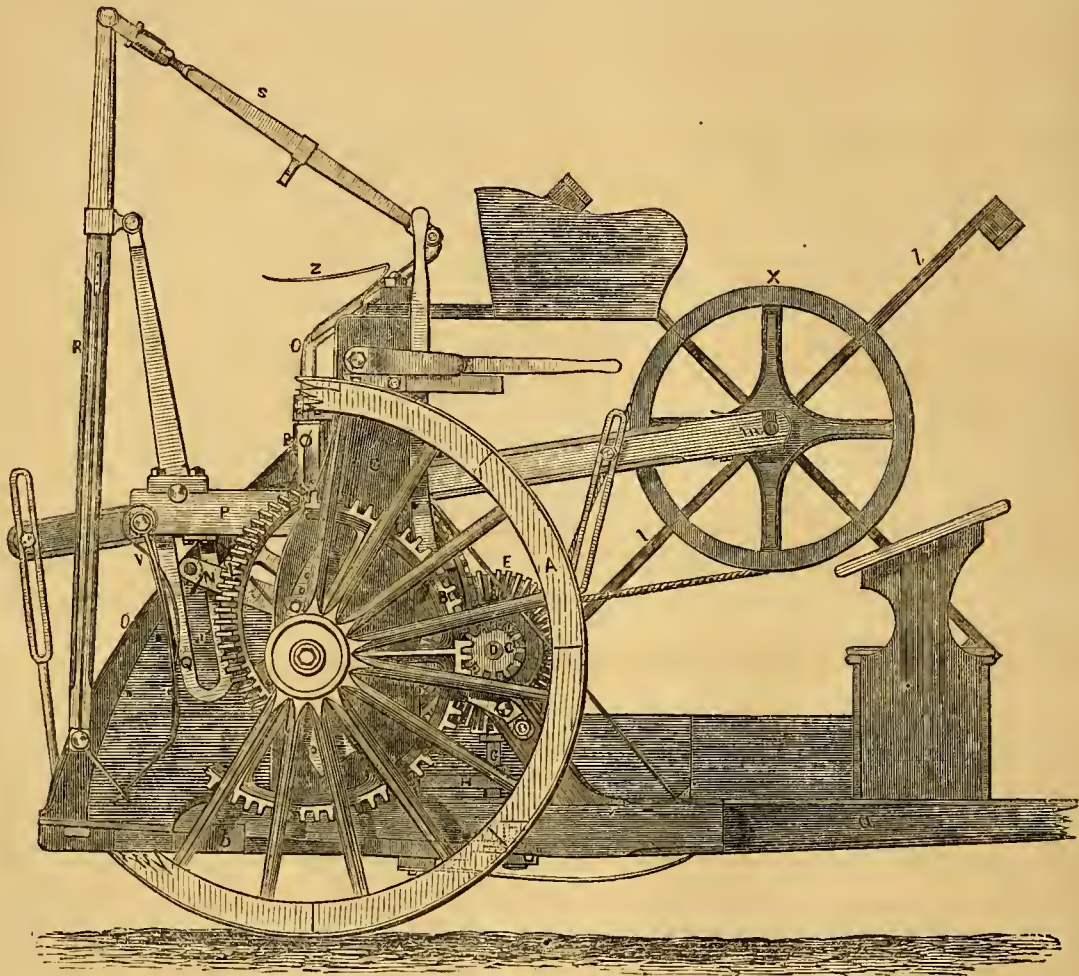

A very extraordinary piece of mechanism, rivalling even the "copping motion" of the self-acting mule in intricacy and beauty of action, has been recently brought over from America by Mr. J. S. Wright, of Chicago, and patented in this country by Mr. J. H. Johnson. This is a self-acting raker for reaping and mowing machines, the invention of Mr. Jearum Atkins, of Chicago, Illinois, originally a millwright, but now, and for some years past, a crippled and disabled man. The entire reaper is represented in the large engravings annexed, to which are added detailed views of the cutting-knife.

Fig. 1 is a side elevation of the reaper complete, but with the shafts and front carrying wheels broken away. Fig. 2 is a corresponding end view of the machine, looking on the raking apparatus from behind; fig. 3 is a plan of the cutter, with its actuating mechanism; and fig. 4 is a corresponding plan of the same.

Framework.—At *a* are two long wooden beams, joined together at their forward ends, and attached by means of a strong iron bolt or draw iron to a pair of front wheels, similar to those of a common waggon, to the tongue of which the horses are attached for working the machine. *b* are two long bars, attached by iron bolts to the under side of the beams, and extending out at right angles with the draft of the machine, a distance equal to the width of swath which the machine is designed to cut, and to the foremost bar the sickle is attached, which, being put in motion, (as hereafter described,) crowds against and cuts off the standing

grain. These bars or sills support a platform, made of boards, and sheeted with iron or zinc on the upper side, on which the cut grain falls, where it remains until a suitable quantity is collected for a bundle. *c* are two posts, framed into the beams, and firmly connected at their upper ends by a cross-bar and long iron bolts, extending through from outside to outside of the posts. These posts are supported on the side next the forward wheels by two wooden braces, which are framed into the beams, forming a part of the superstructure which supports the machinery.

There is a long cross-bar, *d*, resting upon the heads of the posts, and firmly joined to them by means of iron straps, which straps overhang the whole superstructure, and passing down through the beams, are secured by nuts screwed on the under side. This cross-bar extends over the entire platform, and is joined to a brace, *e*, which stands upon the platform, and is supported in an oblique position by another brace, *f*, the foot being framed into the sill which connects the long cross sills supporting the platform, the forward end being pointed and extending forward of the sickle, for the purpose of separating the grain to be cut from that which is to be left standing.

Sickle Gearing.—*A* is a strong wooden wheel, turning upon a cast-iron axle, that protrudes from the side of the post, *c*, and supporting one end of the machine, the other end being supported by a wheel of smaller size.

A spur wheel, n, is keyed on to the boss of the wheel, a, and turns with the wheel by the forward motion of the machine. This wheel gears into a spur pinion, c, on the shaft, d, on which is also a bevel wheel, e, which, by gearing into a bevel pinion, f, on the head of the

perpendicular shaft, g, communicates motion to said shaft, the lower end terminating in a crank, which, through the connecting-rod, i, communicates a vibratory motion to the sickle, j. This sickle operates in a manner similar to the sickles of other reaping machines. On the perpendi-

Fig. 2.

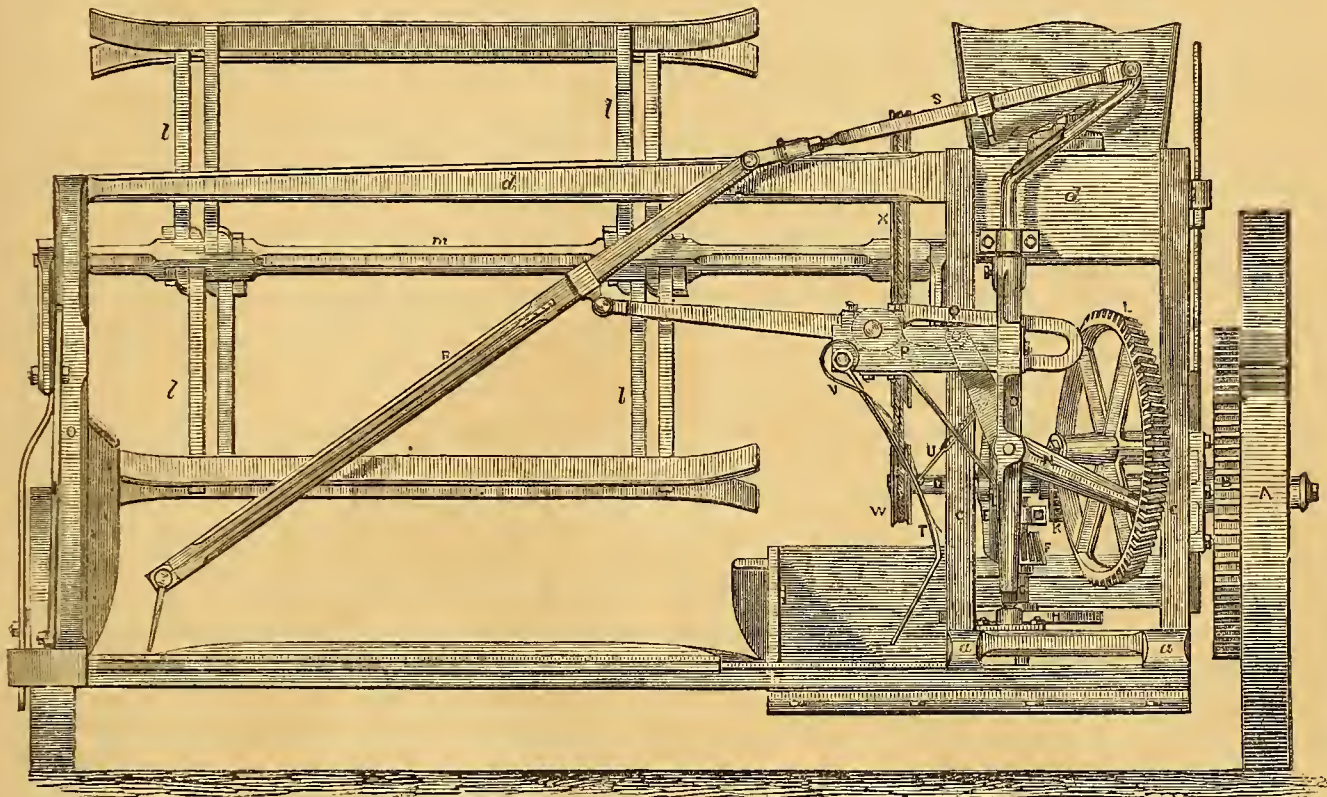

cular crank-shaft, g, is a small cast-iron fly-wheel, n, for the purpose of steadying the motion of the crank, and preventing the vibrations of the sickle from communicating a jarring irregular motion to the gearing.

Raking Apparatus.—Behind the post, c, opposite the main travelling wheel, a, is suspended upon an iron axle a bevel wheel, l, which receives motion by gearing into the bevel pinion, k, on the shaft, d, and communicates motion to the raking apparatus. In the same vertical plane with the centre of the axle of the wheel, l, and at a distance from the wheel, equal to one-half its diameter, stands a vibrating iron post, o, turning in foot-

step bearing, and secured at the top to a horizontal iron pillow block, standing out from the framework. This post has a large opening through the centre, but unites in one bar at its extremities. In the opening in the post, o, and on the same horizontal plane with the axle of the wheel, l, is suspended upon pivots, which pass through the post on either side, a short axis, serving as a fulcrum to the lever, n, which lever is attached to the wheel, l, by means of a socket on the rim of the wheel, into which the end of the lever is nicely fitted, and in which it turns freely as the wheel revolves.

Fig. 3.

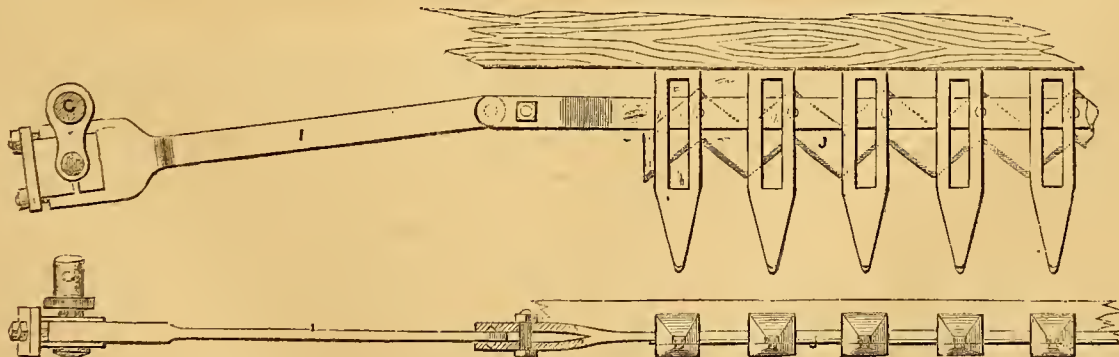

Fig. 4.

Opposite the wheel, secured in the other extremity of the crooked lever, n, is a roller, which turns upon a pin, and rolls freely through a long opening in the lever, q. Two short horizontal wooden bars, p, p, are framed into the post, o, and connected at their outer ends by a bar framed across them. Between these two bars, the iron lever, q, is sus-

ended upon a short axis, which rests upon and is secured to the bars by means of iron caps and bolts. To the outer end of this lever, q, which is forked, the rake, r, is attached by means of an iron clasp spanning round and bolted to the handle or bar of the rake, and turns upon a long iron pin which passes through the fork of the lever.

An iron rod, *s*, connects the upper end of the rake bar with the upper end of the iron post, *o*. This rod is forked at both ends, one end spanning the top of the post, *o*, to which it is secured by a pin, while the other end is secured in the same manner to the upper end of the rake. A steel spring, *z*, rests upon and is riveted to the oblique part of the post, *o*, for purposes hereafter described.

To the cross-bar connecting the bars, *r r*, is suspended by iron hinges a broad sheet-iron plate, *t*, furnished with long teeth on its lower edge, that extend down nearly to the head of the machine. On the back of this plate is a small staple into which the link, *v*, is inserted, the upper end being fastened by a pin which is screwed into the side of the lever, *x*. The plate, *t*, is prevented from turning loosely upon its hinges by means of two coiled springs, *v v*, which are fastened to the bar to which it is suspended, and pass down and press against the back of the plate, on the side next to the link, *v*, by which the link is kept tight.

Movement and Operation of the Raker.—The end of the lever, *x*, attached to the wheel, *l*, moves in a true circle, and has uniform velocity, as will be seen by the uniform turning of the wheel. It will also be seen that the portion of the lever, *x*, which extends from the centre of the post, *o*, to the wheel, describes at each revolution of the wheel the surface of a cone, whose depth is equal to one-half its base, and whose apex is in the centre of *o*.

Let us now suppose the bed of the machine to be covered with grain, and the raker to be set in motion by turning the wheel, *l*. While the wheel, *w*, makes about one-sixth of a revolution, the position of the levers, *x* and *q*, and of the rake and connecting-rod, *s*, will have changed; and the rake will have swept across the entire head of the machine, collecting the grain into a compact bundle against the tooth-plate, *t*. While this operation has been going on, it will be seen that the position of the post, *o*, has not been sensibly changed; but as the wheel continues to revolve, and the lever, *x*, is carried through the upper part of its circumference, the post, *o*, with the whole structure attached to it, will be made to vibrate through a quarter of a circle. The bundle of grain will be carried off the bed entirely around behind the machine, when, by the continued motion of the wheel, an action of the machinery directly the reverse of that which closed up the rake and collected the grain, causes it to open out its full length behind the machine, depositing its contents on the ground; and as the lever, *x*, is carried through the lower circumference of the wheel, *l*, the post, *o*, is turned back a quarter of a circle, the rake thereby being made to swing around over the head of the machine for the similar collection of a succeeding bundle.

In all fields of grain, the quantity which will be thrown into the bed of the machine while the rake is making one revolution, will vary according as the grain is heavy or light. It is therefore necessary that the rake and sheet-iron plate, against which the grain is compressed, should be so arranged, as that they will close sufficiently near to grasp and hold a small, or yield to make room for a large quantity. This object is secured by the springs, *v*, which hold the plate up against the rake with sufficient force to retain whatever may be grasped between them, while, at the same time, they allow the plate to yield, to adapt itself to any increase of quantity. The spring, *z*, is for the purpose of steadying and supporting the connecting-rod, *s*, as it approaches the lower point of its descent, and for preventing that tremulous motion of the rake which would otherwise take place while it is extended. The link, *v*, is for the purpose of holding the plate, *t*, firm against the action of the springs. It will also be seen, that while the rake, after having delivered its bundle, is being swung around for the collection of a succeeding one, this link, by the rising and falling of the lever, *x*, which takes place during the operation, draws the plate back towards the post, *o*, out of the way of the grain which may be lying on the platform, and again, at the proper time, lets it down against the action of the rake.

With reference to the motion of the rake it may be observed, that it is quickest at those points where a quick motion is most needed, as, for instance, while it is sweeping the platform to collect the grain, and while opening in the rear of the machine for delivering the bundle. Again, it may be observed, that when the rake is nearly closed upon the grain, the velocity, which is no longer needed, by the peculiar action of the roller which is fastened in the end of the lever, *x*, and moves in the opening of the lever, *q*, is exchanged for power to compress the grain and hold it firmly to its place, while it is being carried around for delivery upon the ground. This rake has at present but one rate of motion, but is designed to be so arranged by suitable gearing, as that it can be made to take hauls more or less frequently, at the discretion of the operator. The machine has a reel, of which *m* is the shaft and *l* the wings, suspended over and in front of the sickle, for the purpose of inclining the grain back towards the platform preparatory to its being cut, and to bring the cut grain on to the platform. This reel receives motion by means of having a large pulley, *x*, upon its shaft, over

which a belt passes from the pulley, *w*, on the outer arm of the horizontal arbour, *p*.

The Knife—Improvement to prevent Clogging.—It is due to Mr. Atkins to remark that, with the exception of the knife, and finger-points through which the knife plays, the whole arrangement of the reaping, as well as of the raking parts, is original. Mr. Hussey's preference is decidedly for a smooth edge and an acute angle; but other reaper-builders, and several farmers, in whose experience and judgment Mr. Wright places great reliance, consider the sickle edge best, and his preference just now is for a serrated edge, with an angle of about 45 degrees.

Murray's Back-edged Knife.—It will be seen that the knife-bar is on the upper side, and instead of being placed, as usual, flush with the back edge, it is in the middle of the blade, and as far forward as the angle of the cutting will allow. The back, too, instead of being left straight, is cut zig-zag, as shown by the dotted lines, and each alternate edge is beveled the other way, and serrated.

The object to be accomplished is this:—In either reaping or mowing, a fibre hangs upon a finger, and gradually works to the tightest place, and is fastened. Another and another works to the same place, a like process being seen on other fingers, till the knife becomes choked and immovable. The Murray knife-blades resting upon the fingers, and the edges front and rear being in close contact with them, it will be seen that any matter accumulating upon the fingers will be picked off by the sharp points of either the front or rear edge of the knife. It is impossible to choke it.

It is the invention of Bronson Murray, Esq., of La Salle county, Illinois. For several years he had used mowing machines, and was continually troubled with choking of the knife, when the grass was wet either by dew or rain. Three summers since he had constantly to pick out the fingers during a rainy day, when a new plan occurred to him, and taking his knife to a blacksmith, he had triangular pieces cut out of the back edge, and teeth roughly hacked in, returned to the mowing, and has not since been troubled with clogging.

It will also be observed that cutting out these pieces lightens the knife considerably; and being necessarily driven with high speed, and the dead-weight to be twice overcome at each stroke, every ounce there saved is a relief to the team.

Connection of Pitman and Knife-bar.—A difficulty has always existed in the flattening of the holt which fastens together the pitman and knife. With a short stroke, high speed, and several pounds weight in the knife, the bolt does not long continue to work well, being either flattened or broken.

To obviate this, a conical point of steel projects from either side of the pitman or connecting-rod, *r*, about one-fourth of an inch. The knife-bar, *j*, is forked at the end, either fork having in it a conical hole steel-bushed to fit the points on the pitman. The forks being sprung apart to receive the conical points into the holes, are then kept together by a bolt and nuts, and as the knife is driven back and forth, they will spring a little, and in a measure relieve the blow upon the points.

ON THE OCCASIONAL OSCILLATIONS OF THE STEAM-PRESSURE INDICATOR.

I.

In applying the pressure indicator to the cylinder of a steam-engine, it not unfrequently happens that the pencil, instead of calmly rising at the commencement of the stroke, to such a height as we might fairly suppose to be due to the pressure of the steam then entering the cylinder, suddenly bounds to a height considerably greater—often greater, indeed, than the height due to the pressure indicated at the same time by the boiler-gauge. This inordinate leap of the pencil is the first and greatest of a series of oscillations which appear upon the diagram, as undulations of continually decreasing amplitude, and increasing breadth. Like a pendulum moving in a resisting medium, or when retarded by any other kind of uniform resistance, every vibration becomes shorter than that which preceded it, till, finally, the communicated force is exhausted, and the motion ceases; so it is with the piston of the indicator, and therefore with the pencil, which is rigidly attached to it: it oscillates for a time, alternately above and below the position at which the pressure of the steam in the cylinder would at the given instant maintain it; but in every oscillation it makes, it deviates less and less from that position, and finally comes to rest in it. The pencil, from that instant, steadily traces the curve of contemporaneous pressures within the cylinder; for then the tension of the spring of the instrument, and that of the steam, are in equilibrium, and undisturbed by any other force. This state of things continues usually throughout the remainder of the stroke of the piston of the engine, the tension of the spring varying simultaneously, as the elasticity of the steam by expansion becomes less, and finally disappears altogether on the opening of the eduction valve.

The annexed diagram exemplifies this common, though dubious, action of the instrument—often regarded as the effect of some imperfection peculiar to it, and which it ought not to exhibit.

Fig. 1.

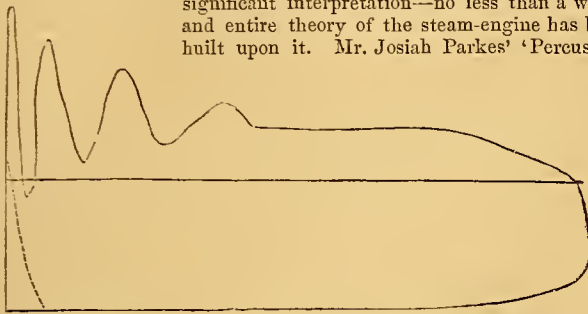

The phenomenon has indeed received a still more significant interpretation—no less than a whole and entire theory of the steam-engine has been built upon it. Mr. Josiah Parkes' 'Percussive

Theory' is still fresh on the minds of many of the present generation of engineers, and stands embalmed for posterity in vol. iii. of the 'Transactions of the Institution of Civil Engineers.' Mr. Parkes' deductions have, indeed, been regarded as erroneous by the greater part of the profession; but although his theory (as he calls it) has been denied and abused beyond measure, it has not been refuted; and he has the satisfaction of knowing, that, for twelve years, no better explanation of the facts he accumulated has been offered. This is in itself some satisfaction for the humiliation attaching to the authorship of a professional blunder; it shows, at least, that the error is not quite elementary; and, after all, it may yet appear, that although Mr. Parkes sadly misconceived the phenomenon which he undertook to explain, his interpretation is still not quite destitute of principle.

Mr. Clark, in his generally excellent 'Treatise on Railway Machinery,' has devoted considerable space to the elucidation of the action of the indicator in its application to the locomotive; and one step further would have given him the key to the true explanation of the oscillations it exhibits so profusely at high speeds. His discussion, as far as it extends, is a good example of practical logic operating with imperfect premises. He has come by much that is true, but not the whole truth, and much that will be appealed to in future, when this phenomenon is discussed.

But, laying aside what has been said and done, we proceed to examine the problem independently, and unfettered by preconceived hypotheses.

Let us examine it, in the first place, by the light shed upon it in the diagram. The pencil of the indicator is driven suddenly to a height, at which the tension of the spring exceeds the counteracting elasticity of the steam upon it; it, of course, descends in obedience to the preponderating pressure of the spring, and it does not stop at the position in which the two pressures upon it are equal, but proceeds below this position proportionally to the height it had risen above it. Again it ascends from this too low position, at which its motion in that direction was expended, and rises to a height proportionally exceeding that due to the steam-pressure in the cylinder, again to descend too low, and so on, through a greater or less number of oscillations. In this way, the piston (and, therefore, the pencil) of the indicator continues to oscillate (nearly equally) on each side of the position in which the two pressures upon it—the pressure of the steam and the pressure of the spring—are equal, every succeeding oscillation becoming less, till, finally, the piston comes to rest under the equilibrium of the pressures acting upon it. As long as the oscillations of the piston continue, the pencil will of course go on tracing an undulating curve upon the paper, or rather a series of waves, of continually diminishing altitude. It will also happen, from the nature of the diagram—that is to say, from the relation of the two motions therein co-ordinated—that the undulations traced by the pencil are not only necessarily highest, or of greatest amplitude, at the commencement of the stroke: it does not yet appear that this is necessarily the case; but also that they are there—as shown in the preceding figure—narrower and more abrupt, their contours approaching to the vertical, and their turning points consisting of acute angles. These characteristics of the lines of undulation traced by the pencil, are obviously connected with the slow motion of the piston of the engine at the beginning of the stroke. As the piston-velocity increases towards the middle of the stroke, the undulations become wider and more rounded at their extremities; their sides deviate more and more from the vertical; and, finally, they would reach their maximum width, were the oscillations to continue so long, when the piston of the engine had reached the middle of its stroke. The reason of this is very easily surmised. The two motions co-ordinated are of different kinds. The vertical motion of the pencil—its oscillations, so long as they continue, are uniform motions—each oscillation may be

supposed to occupy the same space of time; whereas the motion of the piston of the engine is a variable motion, accelerated throughout half the distance, and retarded in the remaining half. And it is this variable motion which in the diagram is the abscissal axis—the length horizontally; and the motion of the piston of the indicator enters into the diagram ordinately. It is therefore plain, that if the oscillations are performed in equal intervals of time, and the paper upon which they are traced by the pencil pass through unequal spaces in these equal intervals, then the undulations must of necessity appear of different widths: they will be narrowest when the pencil is moving slowest, and consequently broadest towards the middle of the stroke of the piston, when the paper is moving quickest.

Taking advantage of this principle, it would be easy to construct an instrument by which the velocity of the piston, at all positions of its stroke, would be represented. It would only be necessary, for that purpose, to connect the pencil with a weighted spring, which, being set in motion, would vibrate isochronously, and the indications representing equal intervals of time would, of course, vary in breadth in the inverse ratio of the velocity of the piston: they would be broadest when the velocity is greatest, and narrowest when the velocity is least. A pendulum might also be substituted for the spring; the spring is, in fact, a pendulum, in which the elasticity of the metal replaces the external force of gravity in the ordinary pendulum. Both obey the same law of uniformity of vibration, independently of the range; whether the amplitude be great or small within proper limits, which it is not here necessary to assign, the time of oscillation remains the same for the same pendulum, no matter what the moving force is, provided only it is a free and constant force.

It has already been noticed, that this phenomenon of oscillation takes place at the commencement of the stroke of the piston; and it may be further observed, that it is most marked in the diagrams of those engines which have the least amount of cushioning, or in which the period of induction is unduly prolonged. It is also a concomitant of all cases of late induction—of all cases in which the steam is too late of being admitted into the cylinder, or when there is some amount of lag. The phenomenon, in fact, occurs invariably when the circumstances are such that the steam is suddenly admitted into a vacuum space; and the more vacuum the condition of the cylinder then is, (when the steam begins to be admitted,) and the more quickly the induction valve opens, the more marked is it; the oscillations of the piston of the instrument, and therefore of the pencil, are proportionally greater in amplitude, and more numerous; or it is longer before an equilibrium of the pressures is established between the spring of the instrument and the elasticity of the steam.

Referring to the preceding figure, it will be observed that the induction is continued to the end of the stroke; that the pencil rises suddenly, describing the vertical line from *a* to *b*, instead of tracing the dotted curve from *c* to *d*, which it would have done, had the induction ceased at *c*, and the quantity of vapour then in the cylinder been retained, and made to serve as cushioning to the piston. At the end of the stroke, therefore, and when the piston of the engine is absolutely at rest, the piston of the indicator is at its lowest position, and the spring of the instrument is about 10 lbs. below its zero at *e*. When, therefore, the induction valve begins to open, the first effect of the steam admitted is to destroy this vacuum, and to add its pressure to that of the spring; for below the atmospheric line, *ee*, the pressure of the steam and the tension of the spring act in the same direction—both act upwards. But we must here clear our notions respecting the nature of the steam-pressure. We are so much in the habit of employing this term as synonymous with the property of expansibility of the fluid, that it has almost ceased to express the relation of an effect; we speak of the elasticity of the steam, its tension and pressure, as identical phenomena, and regard the terms as mutually convertible. This is at least inaccurate, and all inaccuracy of language leads to confused perception. Like other gases, as atmospheric air, steam possesses the property of elasticity—it tends to expand itself indefinitely; and the energy with which that tendency is manifested upon the surface of a retaining envelope, is the tension of the gas—which being known with reference to any convenient superficial unit, as a square inch, and expressed in terms of the weight necessary and sufficient to balance it, is properly termed the pressure.

This is the systematic relation of the terms, as applied to a limited volume of confined gas; but if the gas were unconfined, as in the case of the atmosphere, we might neglect altogether its property of elasticity in speaking of its pressure. This term would then be used to signify the weight of a column of the fluid on the unit-area of base. It is thus that the pressure of the atmosphere is measured by means of the barometer, and stated in terms of the height of the column of mercury which it counterpoises, or of the weight (in lbs.) which that column would

have if its transverse section were exactly one square inch. Now, supposing a barometer, at the time that its column stands at 30 inches of height, (and consequently indicates an atmospheric pressure of 14.7 lbs. on that unit of surface,) to be enveloped by an air-tight casing, along with some portion of the air then surrounding it, the mercurial column would still continue to stand at the same height as before, and no change would be perceived to have taken place in the relation of the two pressures. But now we would regard the pressure as derived from the elasticity of the confined air, whereas formerly we attributed it directly to the weight of the column of atmosphere. We might further increase the height of the mercurial column by forcing more air into the vessel enclosing the barometer, and in like manner diminish it by extracting air, thereby producing effects quite identical in character with those we witness in the exposed barometer, and which we attribute, without hesitation, to changes of atmospheric pressure.

Moreover, if we look a little more closely into the circumstances of the enclosed and exposed barometer, it very soon appears that the two sets of conditions are at least very much alike, if not entirely identical. In both cases the pressure upon the mercury is communicated by a stratum of the fluid, which sustains and is pressed upon by a stratum above it, and this again bears the weight of another stratum overlying it—and so on to the limit of the atmosphere in the case of the exposed barometer, and until the interior surface of the envelope is reached in the case of the enclosed barometer. But in this last case, the surface of the envelope exerts a pressure exactly equal to the amount of pressure which all the strata above it would exert by their weight upon those interposed between it and the surface of the mercurial cistern. Now, it can make here no difference of effect, that the compression is produced by one kind of surface rather than by another—by a surface of iron, rather than by a surface of gas; the mercury will still be submitted to the same amount of pressure, and will therefore stand in both cases at the same height.

For illustration, let us suppose a cylinder so long as to reach to the superior limit of the atmosphere, the pressure of the column of air contained in it will not differ from that exerted on any other equal area, as a square inch. Suppose that it is 14.7 lbs. on this unit. We may also imagine a piston acted upon by a spring to be situated at the bottom of the cylinder, for the purpose of indicating the pressure; and further, that the cylinder is supplied with stop-cocks at certain positions above the piston. Now, it is easy to see that the entire column of gas being in equilibrium, there would be no derangement of that state produced by shutting any one or all of the cocks, with which we have supposed the cylinder to be provided. The pressures exerted on the two opposite sides of the plug, would simply be those which the two contiguous layers of the fluid previously exerted upon each other at that point—the weight which the superior part of the column exerted on that upon which it rested, and the reaction which the inferior part of the column opposed to further compression by the superincumbent weight. The pressures on the two sides of the plug are, therefore, manifestly and necessarily equal; and it is quite as clear, that the circumstances of the part of the column below the stop-cock will not be affected by removing altogether the part above it. The only new condition introduced, by thus annihilating the pressure above the cock, would simply be, that the plug would henceforth be required to sustain the unbalanced pressure; it would be required to resist, in virtue of its position, and by its strength alone, a pressure exactly equal to that previously obtained from the weight of the superincumbent column of gas.

The conclusion then is, that in any body of confined gas, the pressure it exerts on the unit of area of the containing surface is that due to the weight of a column of the gas, having an equal area of base, and a height proportional to that pressure and the density of the gas conjointly. It is not necessary to take into account the condition, that in an open column of the gas, extending upwards in an indefinitely prolonged tube, the density would continually diminish more and more as it ascended; it is only with the weight of the column we have to do, and not with the height to which it would reach, if so circumstanced. This problem may arise as a question of interest in general physics, but it has no importance in terrestrial mechanics. The only possible form in which it can present itself in this relation, is in accordance with the very simple hypothesis, that the density is uniform throughout the entire height of the column, and the same as it is observed to possess at the surface of the earth. For example, at the temperature of 32° F., a cubic foot of atmospheric air weighs 0.080763 lb. under a barometrical pressure of 30 inches of mercury—say 15 lbs. on the square inch; the height, therefore, of a column of air, of that temperature and density through-

out, and exerting that pressure on the unit of base, would accordingly be 26,750 feet, (fully five miles,) and this is called the height of a homogeneous atmosphere. Supposing the temperature of the air to be 212° instead of 32°, the height of the homogeneous atmosphere would then be 36,550 feet, or nearly 7 miles; and a homogeneous atmosphere of steam of this pressure, and at this temperature, would have an altitude of no less than 57,620 feet, or nearly 11 miles. Calculations of this sort are necessary in questions relating to the velocity of sound, &c., but are merely illustrative for the purpose we have presently in view.

We have made reference to the barometer as the instrument by which the pressure of the atmosphere is measured; but it is very manifest that the column of mercury by which the atmospheric column is balanced might be replaced by a piston and spring, but for the mechanical difficulty of the application—the difficulty of maintaining a Toricellian vacuum behind the piston, which we so easily insure above the mercury in the tube of the barometer. The steam-engine indicator would exactly answer the purpose, but for this difficulty; and it is so applied when used to determine pressures lower than that of the atmosphere: what it then determines is the extent to which the atmospheric pressure exceeds the pressure on the other side of the piston—technically, the degree of vacuum. If in these circumstances the vacuum were complete or perfect, it would consequently indicate simply the pressure of the atmosphere. Again, when the instrument is employed to measure the pressure of the steam, that of the atmosphere still enters into consideration; it then indicates how much the steam-pressure acting on one side of the piston exceeds the atmospheric pressure acting on the other side of it.

THE MADEIRA GRAPE DISEASE.

The disease which almost entirely destroyed the grape crop of Madeira in 1852, first exhibited itself as a peculiar kind of mouldiness upon the skin of the young fruit. Examined by the microscope,

Fig 1.



the mouldiness was seen to consist of a species of fungus, known to botanists as *Oidium Tuckeri*. (BERKELEY.)

Our engraving, fig. 1, represents the fungus in the shape of tubular and round elongated bodies, as seen in the field of the microscope. Underneath them are the skin and part of the pulp of the grape. In the pulp are shown several cells, containing, along with chlorophyll, (green colouring matter,) sometimes rhomboidal crystals of oxalate of lime, A, and sometimes raphides, or acicular crystals of sulphate of lime, B.

The fungus itself is composed of oval vesicular bodies, or cells, placed end to end. At first they keep distinct, but in time the ends become

more closely united, as at c, and at length the partitions entirely disappear, when a continuous tube is formed, as we see at d. Each cell contains numerous spores—minute seeds—which, when placed in a suitable nidus, produce new plants like their parents. In the centre of each cell, and surrounded by the spores, is a drop of oily fluid, the nature of which is not known, nor the purpose it serves. A small degree of pressure suffices to burst a cell, and let out the spores. If a cell is placed in water, the walls absorb moisture, and swell, and finally burst. In fig. 2 are shown some spore-cases with spores inside, and other spores that have made their escape. The sacs, or cases, measure in breadth from 0.012 to 0.02 millimètres; in length, from 0.028 to 0.04 millimètres. The spores measure in breadth from 0.004 to 0.006 millimètres, and in length from 0.004 to 0.02 millimètres.

No trace of the fungus has been found in the interior of the grape, nor can anything like a root be discovered in or beneath the skin. When it appears on the leaves, it seems to remain on the outer side of the general integument. Hence, since, to all appearance, only the more tender parts of the vine were affected—most of which decayed in the natural course of things, viz., the grape, the leaves, and green shoots—it is hoped that the trees are not permanently injured, and that, if there be no special circumstances to develop the fungus, the vines of the present year will escape attack. But this is a conjecture, the correctness or incorrectness of which a few months will establish. In the meantime, it must be admitted, the prospects of the island are not very bright. On pruning the plant, it has been found that there is much dead wood to cut away, and that, in what remains, there is an unusually small quantity of sap. But a still worse fact remains to be told. Some of the vines near Funchal put forth unseasonable fruit during January last, and the disease showed itself upon the grapes precisely the same as before.

After the appearance of the disease, the grape ceased to increase in size, and in the end split open, disclosing a little stiff pulp, and stones out of proportion to the size of the fruit. It is thought that the fungus, by filling up the pores of the integument, by abstracting the juice of the interior, and by intercepting the rays of the sun, prevented the usual growth of the grape and its ripening. The bursting open of the grape may be accounted for in this way: the moisture of the skin and the nearest layer of pulp was absorbed by the fungus, whilst the stones and the central part of the pulp grew at the usual rate, the distension of the interior causing the exterior part to give way.

The same fungus attacked parts of various other plants, such as rose leaves and pumpkins; and all the plants which suffered from it gave out a fetid odour, in the same manner as plants attacked by the *uredo caries*, a fungus which occasions what is called *stinking rust*. Some persons attribute the disease to the excessive dampness of the period when the vines were putting out their young shoots, namely, at the end of February, and through the month of March.

It is a very singular circumstance connected with the history of this malady, that not only were the vines of Madeira attacked, but that the same disease attacked the grapes of Spain, Italy, Sicily, the South of France, and parts of Germany and Switzerland, though not to the same extent as in Madeira. In those countries, however, the disease appeared in the grapes of 1851, whilst nothing of the kind was known in Madeira until 1852. The disease assumed its severest form on the Continent in the latter year. The currants of the Ionian Islands were quite lost last season. Another curious circumstance is, that the malady did not make its appearance in Teneriffe until a considerable time after the formation of the grape, so that it had strength to survive the attack, and it yielded the usual quantity and quality of wine. At the Azores, where the vine is cultivated only to a small extent, the disease was not known, nor was the orange, the staple produce of the island, in the least affected.

It is very difficult to obtain an estimate, on which reliance can be placed, of the loss which the island of Madeira has sustained by this disease. I have heard the produce of ordinary years variously estimated at from 18,000 to 25,000 pipes, and the produce of 1852 at from 500 to 3000 pipes. There is no doubt, however, that the wine is all of a very bad quality, and is quite unfit for exportation. In previous years, about 8000 pipes have been sent out of the island.

It seems that the malady was first noticed near Margate in 1845, and its nature was then ascertained. In 1848, it was observed at Versailles, and soon spread through the neighbourhood of Paris. That the fungus is the disease, and not the result of the disease, is thought to be shown in various ways. The disease would not otherwise have spread so rapidly from plant to plant, and from country to country. On the

Continent, the fungus has been removed from individual plants, sometimes by washing, sometimes by fumigation, sometimes by throwing flowers of sulphur over the diseased parts, and in such cases the grapes grew and ripened in the usual manner.

THE ECONOMY OF WATER POWER—M'ADAM'S (BELFAST) TURBINE.

The following rather extraordinary facts may be worthy of the attention of practical engineers and mercantile men. They relate to the results of some experiments made to find the useful effect produced by a turbine water wheel, lately erected here for Messrs. Richardson, Sons, & Owden, designed and made by Messrs. M'Adam of the Soho Foundry, Belfast. This establishment consists of a large spinning mill, and is driven by two steam engines, in connection with the turbine referred to.

The steam engines are of themselves quite able to drive the whole works, and their dimensions are—

Cylinder,	40 inches diameter.
Stroke,	7 feet.
Speed of piston,	336 feet per minute.
Area of piston,	1257 square inches nearly.

In order to arrive at the power of the turbine, the experiments were conducted in the following manner:—

The water being shut off from the turbine, and the entire works driven by the engines at the regular speed, a set of diagrams (No. 1) were taken off the engines, and found to measure as under:

Engine A cylinder, top,	11.31 lbs.
“ “ bottom,	11.88 “
Engine B cylinder, top,	11.87 “
“ “ bottom,	14.08 “

2)49.14

Engine A, No. 1.—Turbine driven without water.

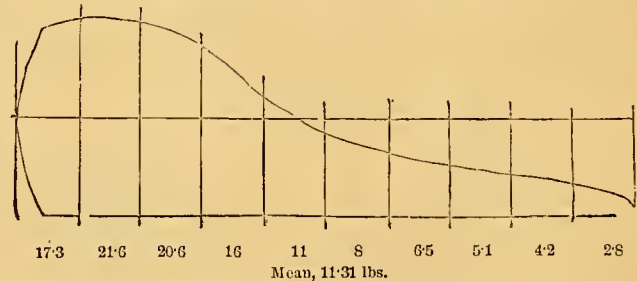

Engine A, No. 1.

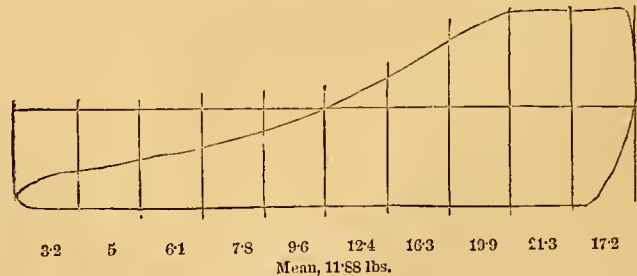

Engine B, No. 1.

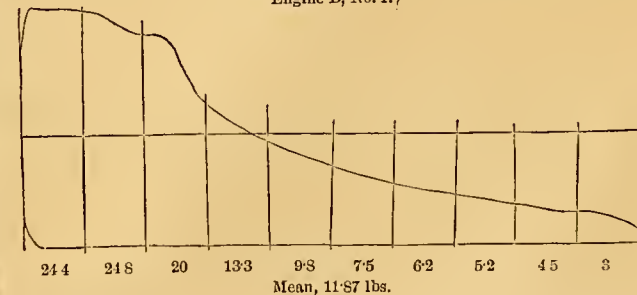

Mean, 11.87 lbs.

Engine B, No. 1.

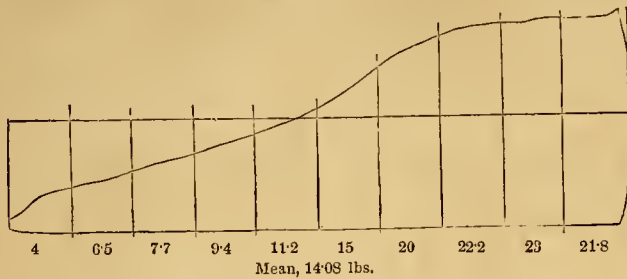

Equal to an average pressure on one cylinder of 24.57 lbs. per sq. inch; and the area of the cylinder being 1257 square inches, the absolute indicated horses' power of the engines will be—

$$\frac{\text{Area. Lbs. Speed.}}{1257 \times 24.57 \times 336} = 314\frac{1}{2} \text{ horses' power nearly, to } 33000$$

drive the whole works.

The next half of the experiment was made by allowing the water to flow through the wheel, and cutting off the steam, till the engines were driving at exactly the same speed as in the former half of the experiment, when a new set of diagrams (No. 2) were taken, which measure as under:

Engine A, No. 2.—Turbine with full water, 11½ inches deep.

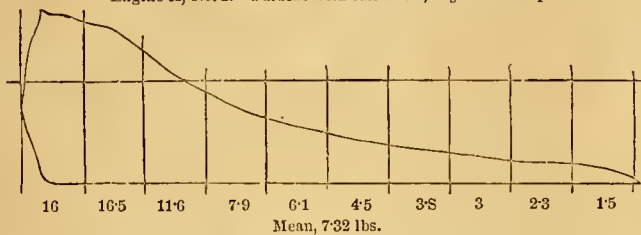

Engine A, No. 2.

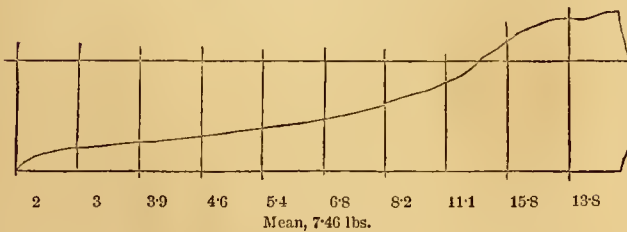

Engine B, No. 2.

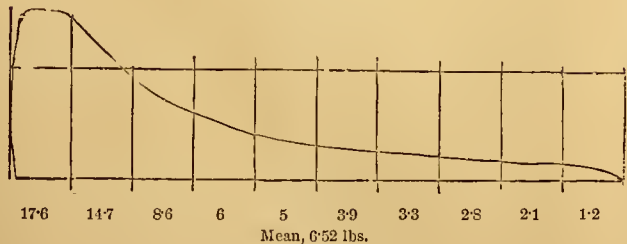

Engine B, No. 2.

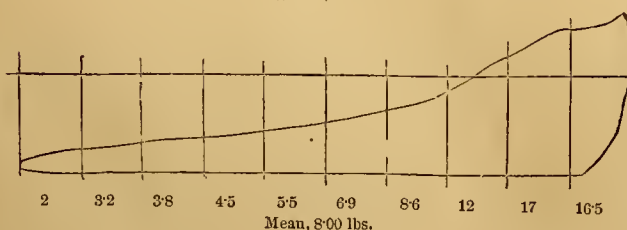

Engine A cylinder, top,	7.32 lbs.
“ “ bottom,	7.46 “
Engine B cylinder, top,	6.52 “
“ “ bottom,	8.00 “

2)29.30

Equal to an average pressure on one cylinder of 14.65 lbs. per sq. inch; and which, reduced to horses' power, will be—

$$\frac{\text{Area. Lbs. Speed.}}{1257 \times 14.65 \times 336} = 187\frac{1}{2} \text{ horses' power nearly, exerted } 33000$$

by the engines when aided by the turbine.

Now, 314½, minus 187½, leaves 127 horses' power as having been accomplished by the turbine; and if we suppose 2 horses' power to be equivalent to the extra friction of the engines when loaded, and 1 horse's power to drive the turbine without water, we still have 124 horses' power as having been given out by the turbine.

The water consumed.—The water is derived from an artificial pond of large extent, in which the water is collected during the night, the top level generally sinking as the day advances. The greatest height of the fall is 48 feet, and at the time of making these experiments it was 47 feet. The quantity of water used was determined by rules founded on experiments made in Scotland some years ago, and which may be seen in any modern book treating of hydraulics.

The method of conducting the experiment is this:—In the tail-race there is a board fixed right across the race, and made water-tight at the bottom and both ends. The water is made to flow over the upper edge of this board, and is confined at each side by perpendicular sides, which reach higher than the height of the overflowing water; the water, therefore, flows over what is called a rectangular notch; and, in the case before us, it was 100 inches wide, and the depth of the water, from the top of the board to the top of the water (at dead level), was 11½ inches.

By the rule above referred to, 11½ inches deep, and 100 inches wide, gives a discharge of 1580 cubic feet per minute; but from this must be deducted the condensing water from the engines, &c., which does not pass the turbine, amounting, by measurement, to 60 cubic feet per minute, thus leaving 1520 cubic feet, as having passed through the turbine per minute.

1520 cubic feet, multiplied by 62½ lbs. (the weight of one cubic foot of water), gives 95,000 lbs. falling through 47 feet, equal to 95,000 × 47 = 4,465,000 lbs., falling through one foot per minute; and this reduced to

$$\frac{4465000}{33000} = 135 \text{ horses' power nearly, without making any allowance whatever for anything. Here, then, we have 135 as the absolute power of the water, and out of this we have 124 horses' power of useful effect. The per centage of effect will therefore stand } 124 \times 100 = 92 \text{ per cent. of the absolute power of the water. } 75 \text{ per cent. } 135$$

is considered a very fair result for the very best water-wheels, but here we have at least 90 per cent. of the total weight of the water consumed; a result far better than anything I ever read or heard of before, and which, I think, is well worthy of the attention of all parties interested in the use of water as a motive power.

In conclusion, I may mention that the above (or similar) experiments have been made repeatedly with results varying but slightly from the above, and in every case the greatest care was exercised; and in order to guard against too hasty conclusions, there were full sets of experiments taken on different days, and also at different times on the same day.

ROBERT DEMPSTER.

Bessbrook, Newry, Ireland, March, 1853.

MECHANIC'S LIBRARY.

Agricultural Chemistry, Farmer's Manual of, 4s. 6d. Normandy.
 Astronomical Observations with Airy's Zenith Sector, 4to, £2. 2s., cloth.
 Bridges, On the Construction of Military, 3rd edition, 21s., cloth. Douglas.
 Chemistry, Encyclopædia of, 2nd edition, 21s., cloth. Booth & Moritt.
 Domestic Architecture, Vol. II., 8vo, 21s., cloth. Turner.
 Electric Illumination, 8vo, 1s., sewed. J. J. W. Watson.
 Elementary Mathematics, Course of, 24th edition, 8vo, 15s., cloth. Goodwin.
 Encyclopædia Britannica, 8th edition, edited by Trail, Part I., 4to, 8s.
 Euclid, Elements of, 12mo, 4s., cloth. H. J. Hose.
 Gold, Practical Guide to Testing, 12mo, 1s., cloth. Keates.
 Great Exhibition, Lectures on Results of, Second Series, 7s. 6d., cloth.
 Life-Boat, Cruise of the "Challenger," foolscap 8vo, 1s., sewed.
 Mechanical Philosophy, Principles of, 8vo, 10s. 6d., cloth. Tate.
 Mines, Records of the School of, Vol. I., Part II., royal 8vo, 2s. 6d., cloth.
 Naval and Mail Steamers of United States, 4to, 50s., half-bound. Stuart.
 Painters' and Grainers' Assistant, 3rd edition, 12mo, 21s., sewed. Barber.
 Patentee's Manual: A Treatise on the Law and Practice of Letters Patent, 8vo, 5s., cloth. J. & J. H. Johnson.
 Practical Mechanic's Journal, Vol. V., 4to, 14s., cloth. Jobson.
 Steam Navy, Letter on a, 8vo, 1s., sewed. Captain Housason.

SELF-ACTING FEEDER FOR BEET-ROOT RASPING MACHINES.

In the treatment of such roots and fruits as the beet, apple, and potato, for the obtaining of their saccharine and farinaceous constituents,

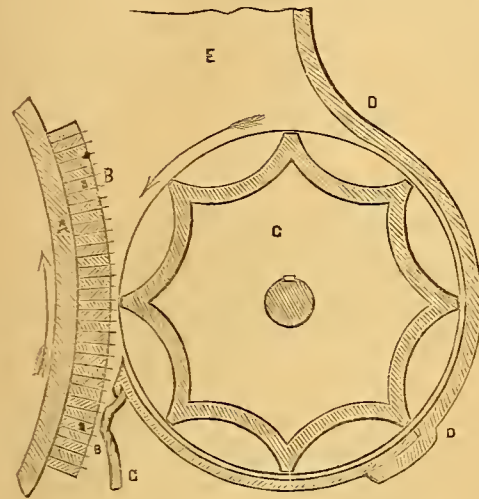

so extensively practised on the continent, the raw productions are reduced to a pulpy condition, by the grinding or rasping effect of a series of saw blades, set on the periphery of a rapidly-rotating cylinder of large diameter. Such matters have usually been fed into the rasping machine, by being thrown into chests fitting to the rasping face of the cylinder, a labourer stand-

ing by to push up the pieces to the saw-teeth, by means of a pair of wooden blocks, termed "pushers," or "poussoirs," one being grasped in each hand, and applied alternately to feed up the materials. By this rude system of feeding, much time was lost, whilst the pulpy reduction was never accomplished to the satisfaction, as regards uniformity, of the advanced manufacturer. This was especially the case in the best sugar works, now so extensively spread over the continent; and a Magdeburg machinist has therefore introduced a self-acting feeder, which we now engrave.

In our figure, A, is a portion of the cast-iron cylinder, on which the saw blades, B, upwards of 200 in number, are mounted, and kept at the required intervals apart by means of filling-in pieces of hardwood. The rotatory feeder, C, is a deep and coarsely-fluted cast-iron cylinder, of the same length as the cutting face of the saw-drum—a cast-iron cover, D, being fitted to encircle and cover in the greater portion of the feeding surface. The upper portion of this cover, in conjunction with the drum face, forms a hopper, E, into which the roots are thrown, as the only feeding action required. The arrows indicate the direction of rotation of the two revolving parts.

The action of this simple but accurate feeder is plainly obvious; for as each fluted recess comes round, it contributes its quota of the raw substances to the cutting surfaces, keeping up a constant and uniform supply.

As the saw-blades wear shorter by use, and by the occasional sharpening which is necessary, the lower portion of the feeder cover is made adjustable, and its front portion is always kept as near as possible to the saw-teeth by the piece, C, so as to prevent the escape of any partially unground matters—the finely reduced pulp only being permitted to fall through.

Whatever portions escape past the feeder ridges, instead of meeting the saw-teeth fairly, are again rapidly carried forward, as the feeder revolves, for a second presentation to the cutters, mixed up with whatever fresh deposits have been made in the meantime through the hopper. The feeder is driven from the drum-shaft by means of a double-speed cone, making from 20 to 60 revolutions per minute, whilst the drum makes 1200. At this rate of working, a drum, 40 inches in diameter, 20 inches long on the face, and mounting 240 saws, is capable of converting five tons of sugar beet-roots into a fine homogeneous pulp per hour. Under the old manual system, reducing half this quantity could be got through, and that by no means well and uniformly disintegrated.

RECENT PATENTS.

BRUSHING AND CLEANSING.

C. B. CLOUGH, Tyddyn, Mold, Flintshire.—Patent dated Aug. 19, 1852.

These improvements relate as well to certain mechanical arrangements of rotary brushes for various cleansing purposes, as to the application of gutta percha, leather, india-rubber, or other elastic material, to form the foundations of brushes, as well as for the rollers employed in the apparatus.

Fig. 1 is a side elevation, and fig. 2 a front view of a small apparatus applicable to ordinary domestic purposes of brushing and cleansing; but

adapted principally for use at doorways and other places, for brushing and cleansing boots, shoes, &c., and drawn to a scale of about two inches to a foot. *a* represents the framework or standards of the apparatus,

Fig. 1.

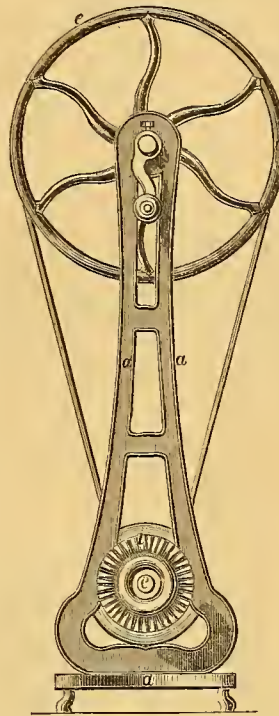
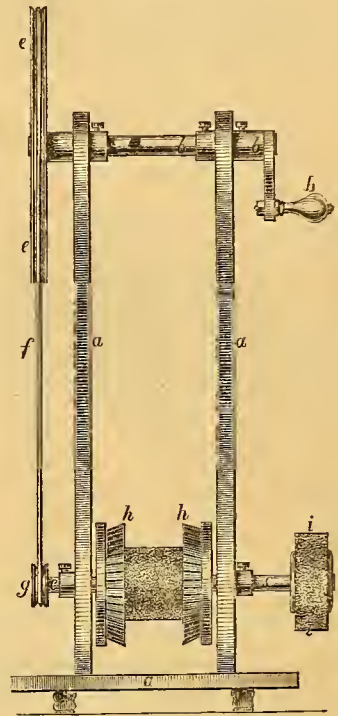

Fig. 2.



supporting two revolving shafts, *b* and *c*. The upper shaft, *b*, is the driving-shaft, and is furnished with a winch-handle, *d*. Upon the other end of the shaft, *b*, a pulley, *e*, is keyed, giving motion to the shaft, *c*, by means of a gut or cord, *f*, passing round it, and the small pulley, *g*, at

Fig. 3.

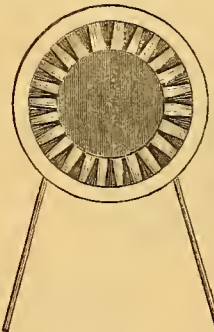
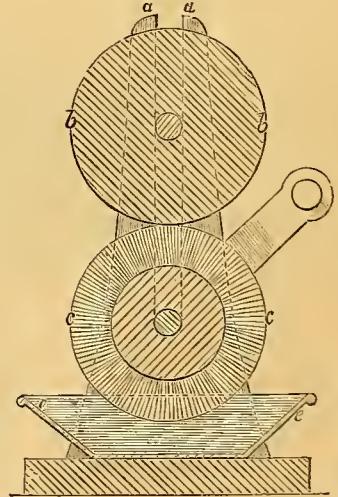

Fig. 4.



the end of the shaft, *c*. Upon the shaft, *c*, are keyed two brushes, *h* and *i*, which, upon the handle, *d*, being turned by an attendant or otherwise, will revolve swiftly, and thereby brush or clean boots, shoes, or other articles that may be held in contact with them. Fig. 3 is

another construction of brush (having an interior set of brushes), that may be employed instead of, or in combination with, either of the before-mentioned brushes. Fig. 4 represents a section of a small apparatus, which is adapted principally for the purposes of laying on, by continuous brushing, paste, gum, colour, paint, tar, varnish, or any other similar material, on to paper and fibrous fabrics, and for other similar purposes. *a* are the standards of the apparatus in which the journals or axles of the roller, *b*, and revolving brush, *c*, are mounted. Upon one end of the axles of the brush, *c*, a winch-handle, *d*, is keyed. *e* is a trough or reservoir to contain the paste, colour, or other fluid or material to be laid on. The method of using this apparatus is as follows:—first, raise the roller, *b*, and place the end of the paper or fabric between it and the brush, *c*; then lower the roller, and turn the winch-handle, *d*.

STEAM-ENGINES AND BOILERS.

JOSEPH HARRISON (of Philadelphia), Oxford Square, London.
 Enrolled June 8, 1852.

The improvements specified by Mr. Harrison relate to boilers of the marine, locomotive, and stationary kinds. Figs. 1, 2, 3, and 4, represent an arrangement suitable for marine purposes. This plan does not differ externally from boilers now in use; but the arrangement of the heating surface varies from the usual mode, these variations having been made with a view to obtain a more efficient kind of fire surface, as well as to increase this surface without enlarging the size of the boiler. The fire-box is carried forward from the fire-place some distance into the interior of the boiler, to which it conforms in shape, and is surrounded with a water-space, as shown in fig. 3. The open space in

Fig. 1.

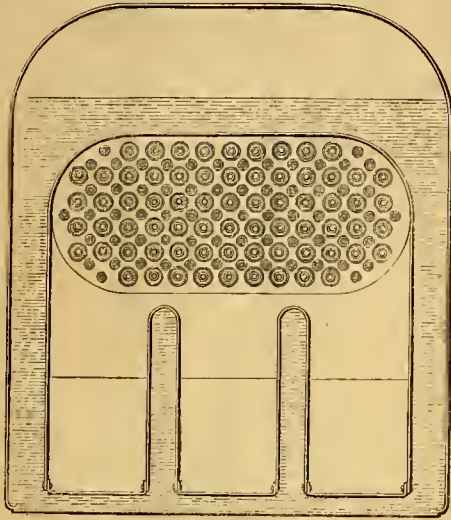

the fire-box above the fire is filled at certain intervals with horizontal tubes, distributed as delineated in fig. 1, leading from the water-space immediately over the fire-doors, to the extreme end of the part of the fire-box extending into the boiler. These tubes have water covering their interior surfaces. After the flame and combustible gases have passed

Fig. 2.

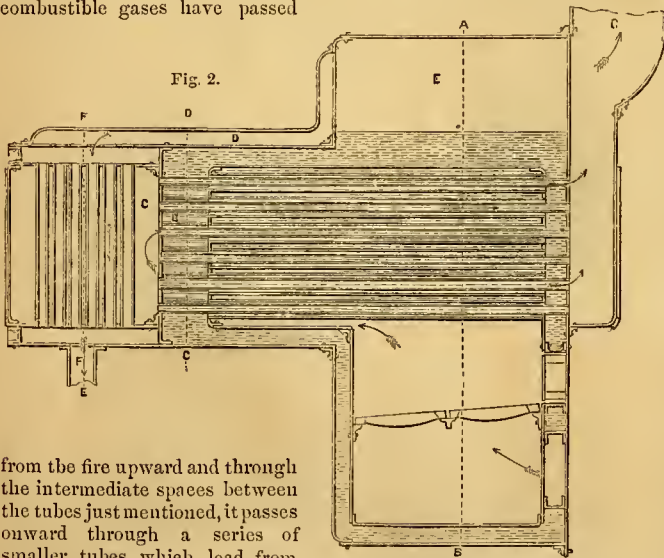

from the fire upward and through the intermediate spaces between the tubes just mentioned, it passes onward through a series of smaller tubes, which lead from the external fire-box to the smoke-chamber, c, through the water-space, v. The smoke-chamber, c, has a series of vertical tubes, so disposed as to leave the tubes leading from the fire-box free for cleaning, from the front end of the boiler; and the heating surface in the smoke-chamber is arranged so that it may be used either for generating steam by surrounding it with water, or the water from the boiler may be shut off by shutting the holes leading from the water-space, v, to the jacket of the smoke-box, if required. In the latter case, the smoke-chamber is intended to be used for drying or superheating the steam previous to its entering the cylinders of the engine; for which purpose, the steam-pipe, n, figs. 2, 3, and 4, may be arranged so as to bring the steam from the steam-chamber, e, to the top of the smoke-chamber, whence it is brought in contact with

the interior heated surfaces of the smoke-chamber, and is discharged in its way towards the cylinders at the opening, F; or the opening, F, being closed, and the surface of the smoke-box and interior vertical tubes being filled with water, and used for generating steam in like manner with the other parts of the boiler, then the steam-pipe, n, serves as a means of conveying the steam from the top of the smoke-box to the steam-chamber, e. After the combustible gases from the fire-box have been brought in contact with the interior surface of the smoke-chamber and the vertical tubes contained therein, they return again to the back end of the boiler through a series of tubes which lead from the smoke-chamber to the chimney, a, passing through the entire length of the series of tubes first alluded to.

Fig. 5 shows a mode of making a fire-box or boiler stay, which is intended to be used in the boiler just described, as well as in all the other of these improved arrangements of boilers. This is in place of the ordinary screw-stay for connecting the exterior to the interior parts of the furnace or fire-box. This stay consists of a wrought or cast-iron tube, one end being closed so as to present a rounded end. The contrary end, which forms the stay, is turned conical at the point, A, and is made to fit steam-tight into a corresponding conical hole in the interior of the furnace, either above or in the vicinity of the fire. After passing through the interior sheet of the furnace, this tube is prolonged until it reaches the interior side of the external sheet of the boiler or fire-box. Directly opposite this tube, a hole is bored through the exterior plate to allow a bolt to pass through, so as to draw the tube tight into the conical hole, thereby connecting the inner and outer surface of the fire-box, and making a secure stay.

Free circulation is made into the interior of this stay by two or more holes made through the portion of the tube in the water-side, which permits free ingress of water, and egress of steam in the direction of the arrows. The object in making the stay in this form, is to secure the very efficient fire surface surrounding the part which extends into the fire-box, and at the same time to make a secure stay, removable at pleasure without difficulty, by simply unscrewing the bolt,

Fig. 3.

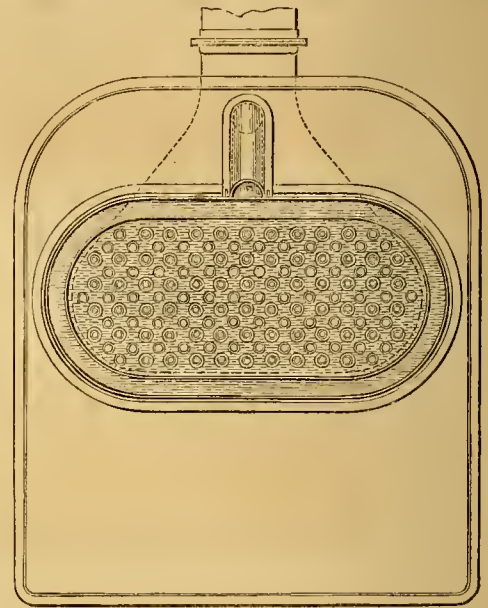

Fig. 4.

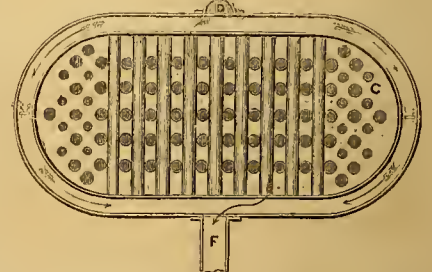
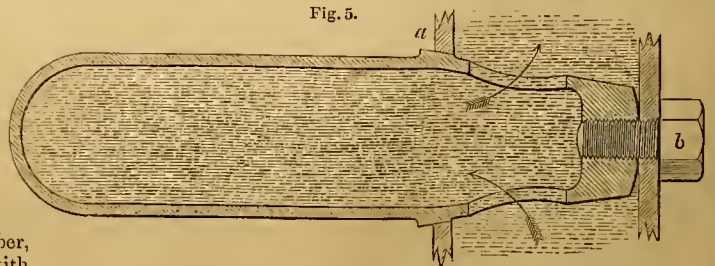

Fig. 5.



is a matter of much importance in boiler repairs. The use of such stays enables the boiler to be more thoroughly cleaned, by taking them out occasionally at the points where mud or other matter is most likely to collect. It will be seen that the tubular stay, above described,

will enable them to be cleaned or taken out, if necessary. These tubes may be placed in the intermediate space between the present stays. The ordinary stays may be removed, and the new arrangement of tubular stay used between each of these cross tubes, and at any other parts of the fire-box, either above or around the fire, where it may be

Fig. 6.

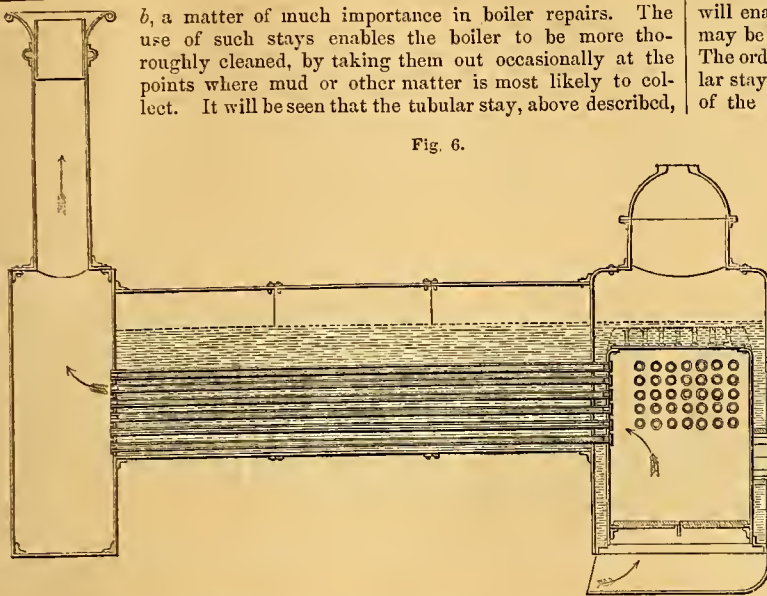

Fig. 7.

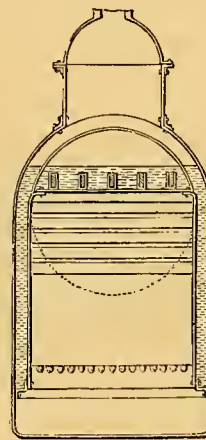

Fig. 9.

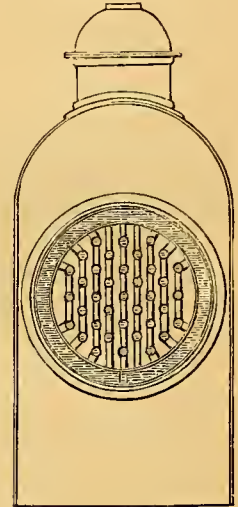

Fig. 8.



deemed necessary. This arrangement of cross tubes may be applied, as well as the tubular stay, to any locomotive boiler now in use, thereby increasing the fire surface to a very considerable extent, at the part where it is most efficient.

These improvements may also be applied to marine or other boilers, at any parts of the fire-box or flues

does not differ so far, as it is used for increasing fire surface, from the "teats," well known and long used, the improvement consisting only in the mode of putting them in so as to make them act as a stay.

Figs. 6, 7, and 8, represent a boiler as at present used for locomotives, with certain additions for increasing the fire surface in the fire-box. These additions consist in using the tubular stay, which has been alluded to in the description of the new marine boiler, and in placing a series of tubes fitted with water across the fire-box above the fire. A series of screw-plugs opposite each tube

Fig. 10.

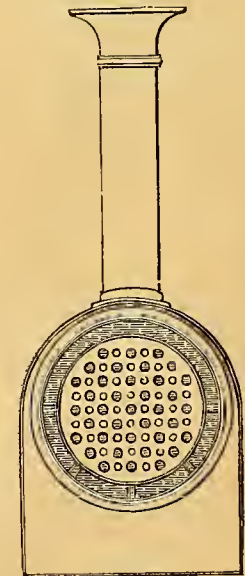
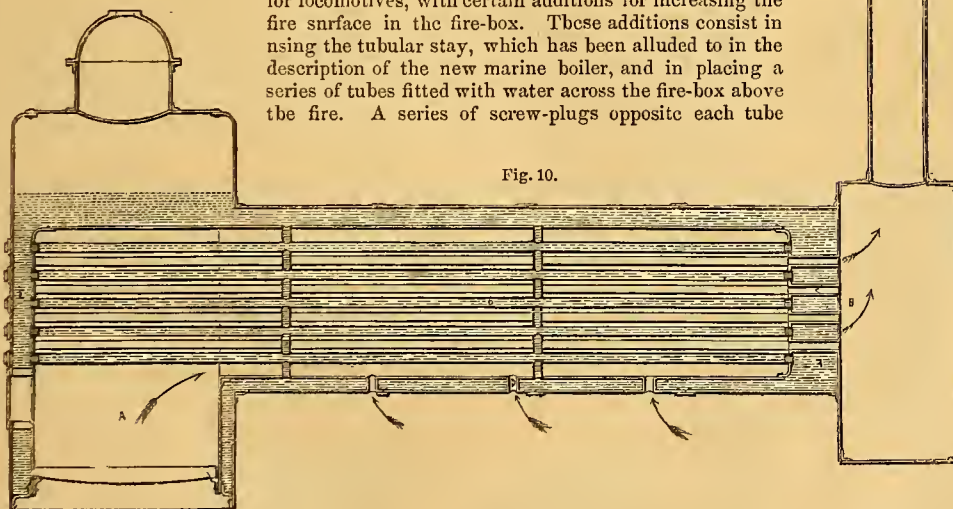

Fig. 11.

Fig. 12.



where it would be advisable to increase the fire surface.

Figs. 9, 10, and 11, show an arrangement somewhat similar to the mode of constructing marine boilers, as previously described. In this case, also, the external form of locomotive boiler is precisely similar to that generally in use, the variations being in the mode of getting fire

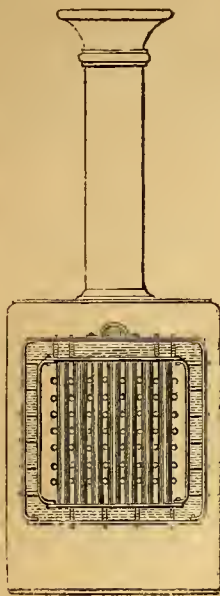

Fig. 13.



surface in the interior of the boiler and fire-box. The fire-box is extended forward, as in the instance of the marine boiler; it is cylindrical in form, as shown in the section, until it reaches within such distance of the tube sheet at the smoke-box, B, as may be deemed most desirable. A series of tubes, D, D, figs. 10 and 12, containing water, leading from the back water-space, F, to the front water-space, E. These tubes are so disposed as to let the flame and combustible gases from the furnace, A, pass between and around them in their journey forward to the end of the internal cylinder, after reaching which, the heat that may still remain unabsorbed, passes on through the tubes, C, C, which run through the water-space, F, F, into

Fig. 14.

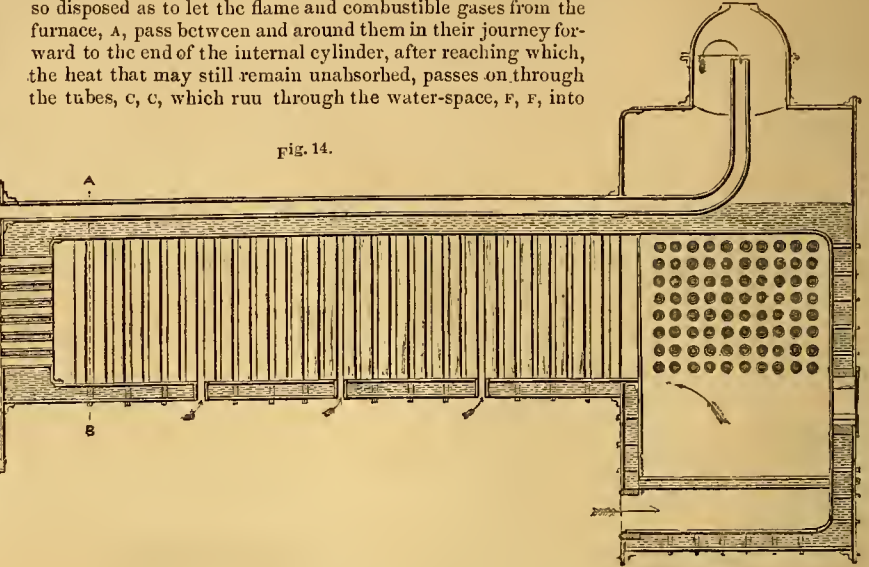

Fig. 16.

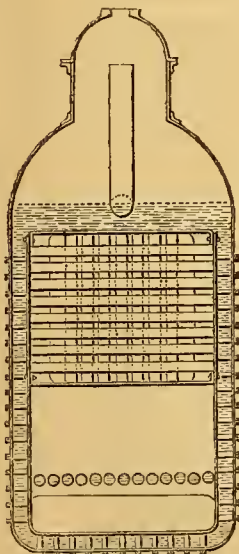
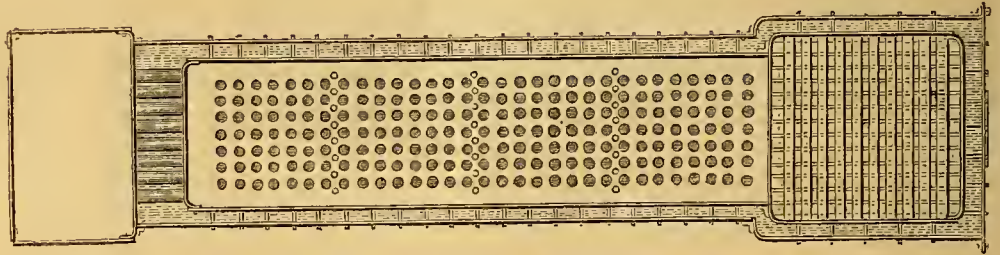

Fig. 15.

the smoke-chamber, B, and up the chimney, in the direction of the arrows. For the purpose of supporting the tubes, D, D, it is intended, if necessary, to connect each row vertically with a small pipe or pipes, connected with the water-space surrounding the interior cylinder, thereby adding to the means of circulation, and, at the same time, supporting the longitudinal tubes. By experiment it is found that these tubes, D, D, may, in most cases, be made so short that no stay or support will be needed, whilst, at the same time, a sufficiency of surface can be brought in contact with the fire to take up all the heat that may be generated. The faint lines in fig. 11 show the arrangement of short flues leading through the water-space, F, F, into the smoke-chamber, B. For sustaining a more perfect combustion of the gases that pass from the fire, holes are made below, so as to let in at pleasure a certain amount of pure air, which will become partially heated in being allowed to circulate between the sheet-

Fig. 18.

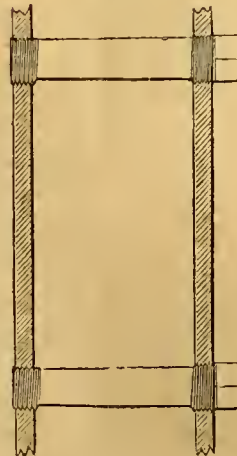

Fig. 19.

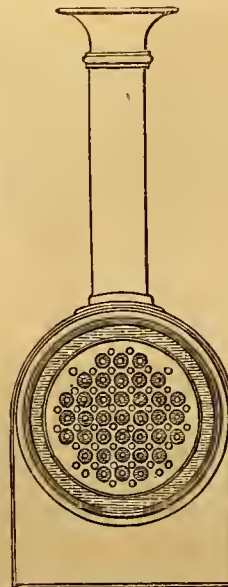
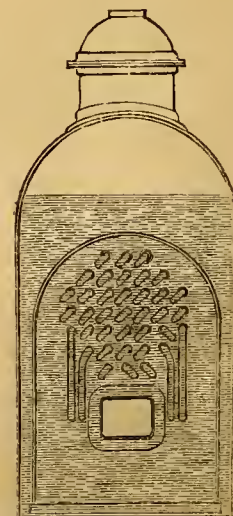
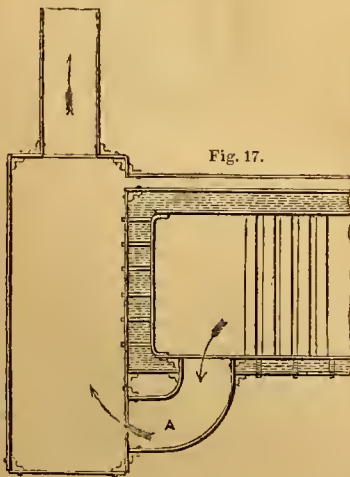

Fig. 20.



the smoke-chamber, B, and up the chimney, in the direction of the arrows. For the purpose of supporting the tubes, D, D, it is intended, if necessary, to connect each row vertically with a small pipe or pipes, connected with the water-space surrounding the interior cylinder, thereby adding to the means of circulation, and, at the same time, supporting the longitudinal tubes. By experiment it is found that these tubes, D, D, may, in most cases, be made so short that no stay or support will be needed, whilst, at the same time, a sufficiency of surface can be brought in contact with the fire to take up all the heat that may be generated. The faint lines in fig. 11 show the arrangement of short flues leading through the water-space, F, F, into the smoke-chamber, B. For sustaining a more perfect combustion of the gases that pass from the fire, holes are made below, so as to let in at pleasure a certain amount of pure air, which will become partially heated in being allowed to circulate between the sheet-

Fig. 17.



iron jacket and the boiler, before entering the tubes.

Figs. 13, 14, 15, 16, show an arrangement of a locomotive boiler, somewhat different from the one last described. It has the middle or waist part of the boiler, between the smoke-box and fire-box, made square, with the corners slightly rounded. The fire-box is extended forward, also of square form, with a regular water-space surrounding it within; it reaches within a short distance of the tube sheet at the smoke-chamber. Instead of the horizontal tubes filled with water, the interior chamber forward of the fire-box is filled with vertical tubes containing water, so arranged as to allow the flame from the fire to pass in between and amongst them, until it reaches the forward end, when it passes off into the smoke-chamber through a series of tubes surrounded with water.

Fig. 23.

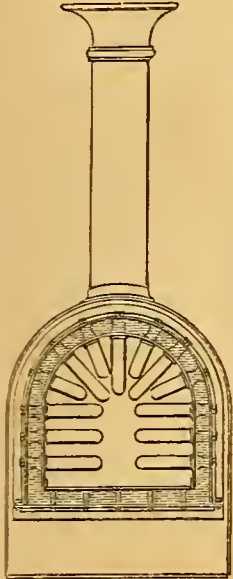

Fig. 17 shows an arrangement of this boiler, wherein the tubes leading into the smoke-chamber are dispensed with, the smoke being carried off through the curved flue, A, into the smoke-chamber. If it is required, the square part of the prolonged fire-box may be carried entirely into the smoke-chamber, and the entire intermediate space filled with the vertical or cross tubes, thereby dispensing with the short flues leading into the smoke-chamber, as well as with the curved flue last described. Figs. 14 and 18 show the lower part of a fire-box for a

Fig. 24.

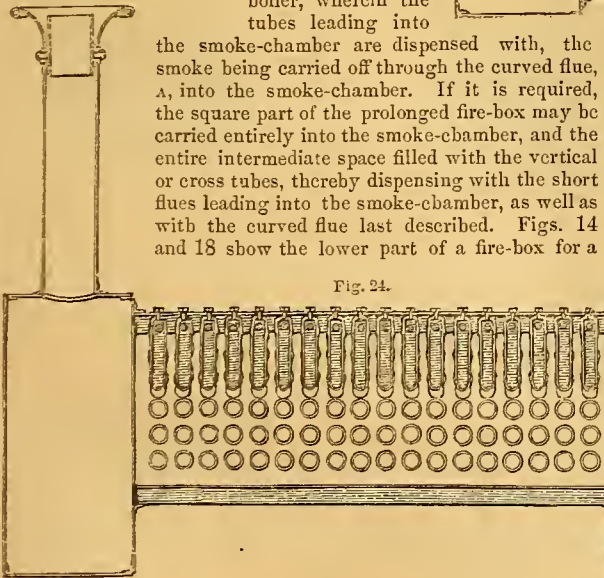
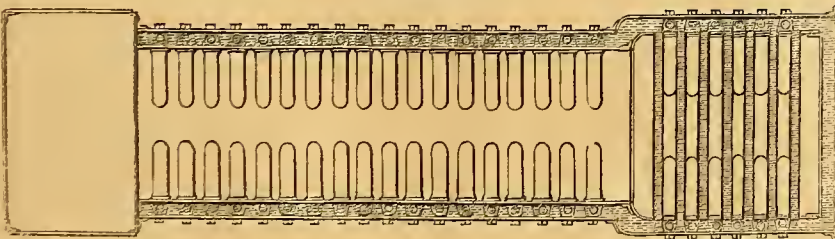

Fig. 26.



locomotive boiler, made like the ordinary marine boiler, thereby dispensing with the usual ash-pan, and admitting a simple mode of making a water-grate, by introducing tubes, lengthwise or crosswise of the fire-box, filled with water, and connecting the opposite water-spaces of the fire-box. In this arrangement it is intended to put the boiler together with the screw bolts, so that the back of the fire-box may be easily removed, after which, by removing the stays and short tubes in front, the whole interior fire-box may be taken out for repairs.

Figs. 13, 14, and 15, show the same arrangement of steam-pipe as is shown in the marine

Fig. 21.

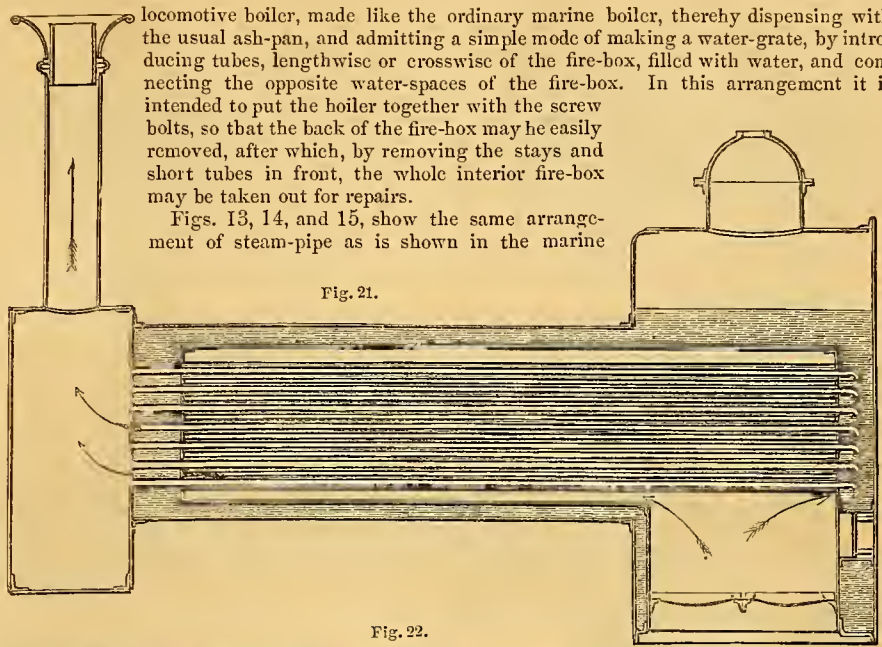
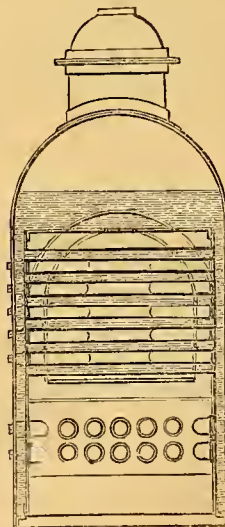

Fig. 22.



Fig. 25.



boiler. Figs. 19, 20, 21, and 22, show an arrangement of boiler suited to the present form of locomotives—a portion of the flame, or combustible gases, being passed through the tubes containing water, by means of the tubes with the bent ends connecting them with the back plate of the furnace, and leading thence into the smoke-chamber. Figs. 23, 24, 25, and 26 show another modification of the locomotive boiler. In this instance the fire-box is extended into the forward part of the boiler without interruption, until it reaches the smoke-chamber, making a clear

open space or single flue, half round at the top, straight sides and bottom, with rounded corners. To obtain the necessary amount of fire surface in this boiler, the whole interior surface is studded at regular intervals with tubular stays, of such length and diameter as may be found most convenient, and so distributed as to bring the greatest amount of surface in contact with the flame or heated vapour, previous to its reaching the smoke-chamber. It is intended to put this boiler together in such a manner with bolts, as will enable it to be taken

apart without difficulty, after taking out the tubular stays. Figs. 27, 28, 29, 30, 31, and 32, show a slight modification in the mode of arranging the water-pipes in the interior of a locomotive boiler. In this case, the tubes or pipes containing water are made much larger than in any previously described; and the mode of attaching the ends of the tubes is slightly different, as, instead of passing from end to end of the fire-box, they are in some cases attached to cross pipes in the fire-box, and in others are bent at right angles, and attached to the cylindrical part of

the fire-hox. Fig. 27 shows a mode of putting in the inside flue, so as to take the flame at any point of the tube containing water that may be deemed most advisable. A small tube, flattened on one side, is put across the tube containing water; into this the cross tubes are fixed, the smaller flue leading to the smoke-box. Fig. 29 shows an arrangement for introducing atmospheric air into the fire-hox, and for heating it before it is allowed to mix with the combustible gases evolved from the fire: two or more pipes of cast or wrought-iron, or of fire-clay, if necessary, are placed

Fig. 27.

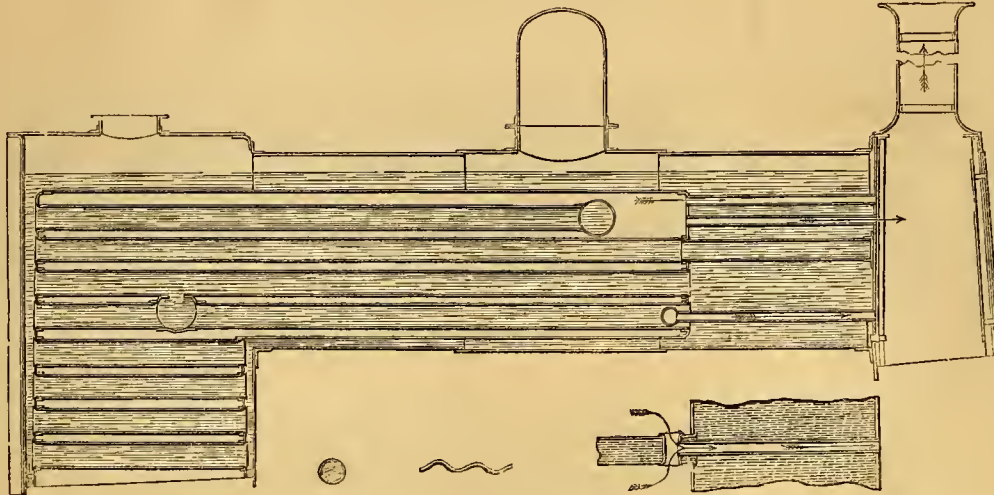

Fig. 30.

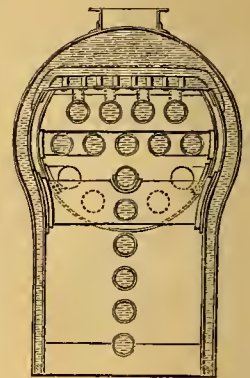

Fig. 28.

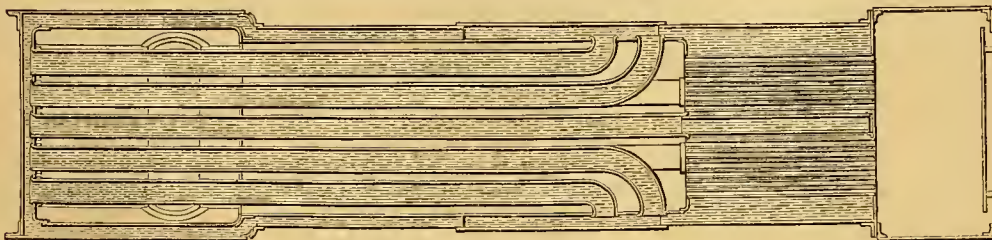

Fig. 31.

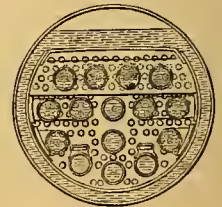

Fig. 29.

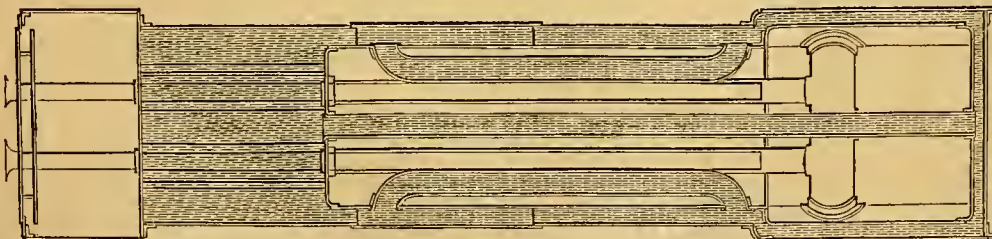
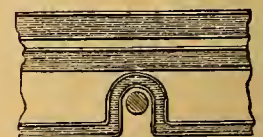

Fig. 32.



within the fire-box, extending forwards to the tube sheet, fitting closely to the tubes that come opposite to them. Pipes are fitted to the tubes leading through the smoke-hox to the external air, which are furnished with funnel-shaped mouths, so that the forward motion of the engine, as well as the vacuum caused by the escape steam, will cause the air to pass with great velocity through the pipe across the smoke-chamber, and through the tubes leading from the smoke-chamber to the fire-box, and into the tubes placed in the fire-hox. By passing through these last-mentioned tubes, which will be highly heated, the atmospheric air will become also heated; and when mixed with the combustible gases within the fire-hox, will cause a much more perfect combustion of the smoke and gases than could take place without the introduction of fresh atmospheric air. By this arrangement of introducing heated air in connection with

the peculiar form of fire-hox, whereby more space is given for combustion, and a consequent better mingling of the oxygen with the gases, coal may be burned in locomotives without inconvenience from smoke, thereby causing great economy in fuel. It is usually intended to make the prolongation of the fire-hox cylindrical in form, and to prevent it from crushing by external pressure; or it may be made corrugated. By this means all stays between the inner and outer cylinders may be dispensed with, excepting a few to support the inner cylinder in its place.

Under the third head the patentee describes a "stationary or chimney boiler," intended to accomplish a more perfect combustion of the fuel, and a consequent consumption of a greater portion of the smoke, and at the same time to dispense with the very expensive towers now used as chimneys. Figs. 33, 34, and 35, show vertical and horizontal sections of the

Fig. C.

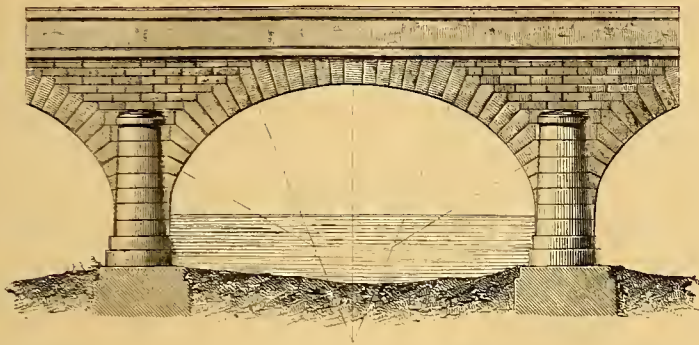

Fig. B.

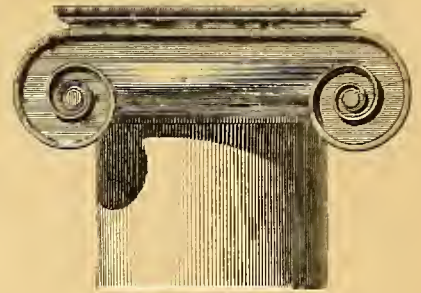
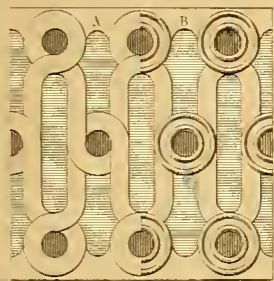
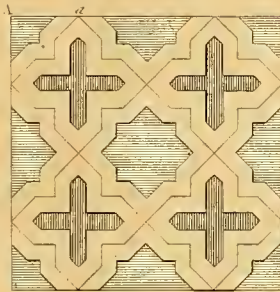

Fig. J.

Fig. K.



AB = 220



Aa = 90

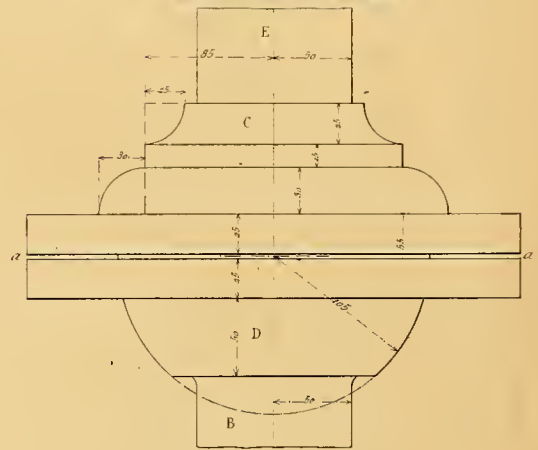
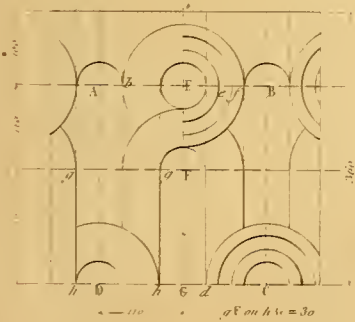

Fig. 3.

Fig. 10.

Fig. 11



of on h is = 30

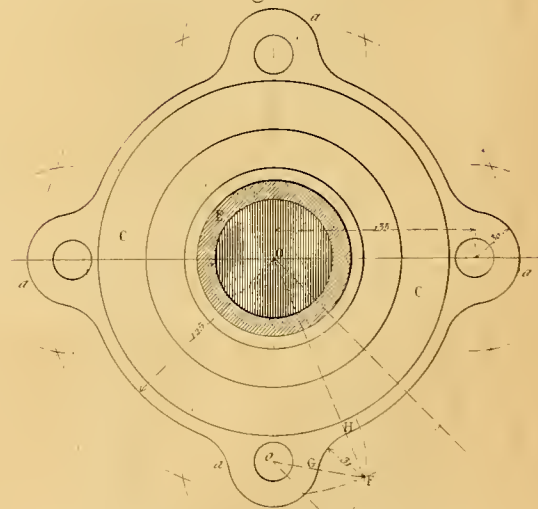
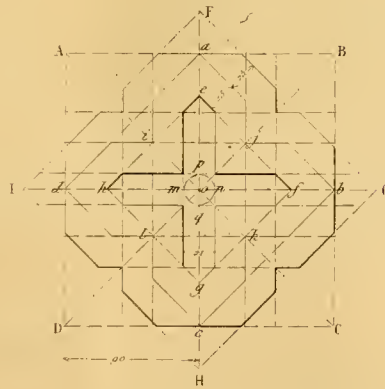
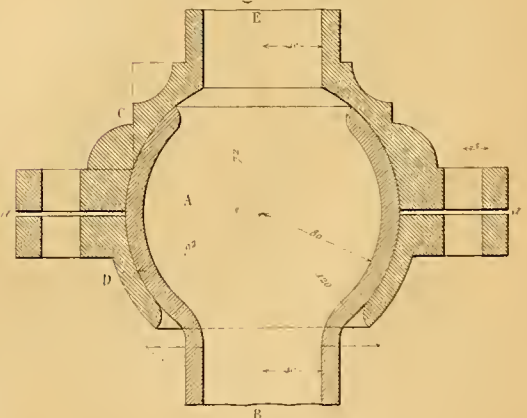
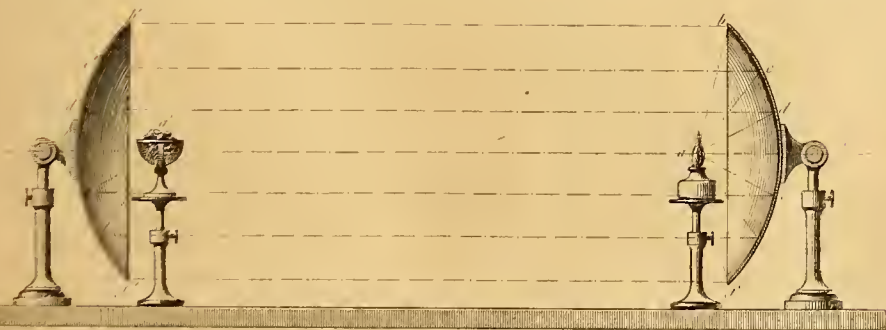

Fig. 5^b

Fig. D.

Fig. D²



chimney boiler; it is of circular form throughout, for facility in making, and for greater strength. The flame and combustible gases from the fire-box or furnace, A, ascend and in part pass off through the flues, B, seven in number, and through three smaller flues. The remaining portion of the flame passes from the fire through short flues, into the upper chamber of the boiler, coming in contact, in their passage to the top of the boiler, with the external surface of the seven vertical tubes, through which the flues, B, pass, as well as in contact with the three vertical tubes, through which the smaller flues pass. The flame and gases, after they reach the top of the inner chamber of the boiler, are carried out to the external air, through a series of small flues, leading from the roof of the interior chamber to the extreme top of the boiler. For a more perfect combustion of the gases in the upper chamber, a series of jets of pure air may be admitted, at convenient points, through the outer diameter of the boiler. It is intended to surround the boiler with a casing, leaving a small space between it and the exterior surface of the boiler. The air being taken from the space just mentioned, will be partially heated before entering the boiler, and

consequently better adapted for aiding the combustion of the gases which may have passed off from the fire into the upper chamber. At any part of this boiler, either in the fireplace or upper chamber, where a stay may

Fig. 33.

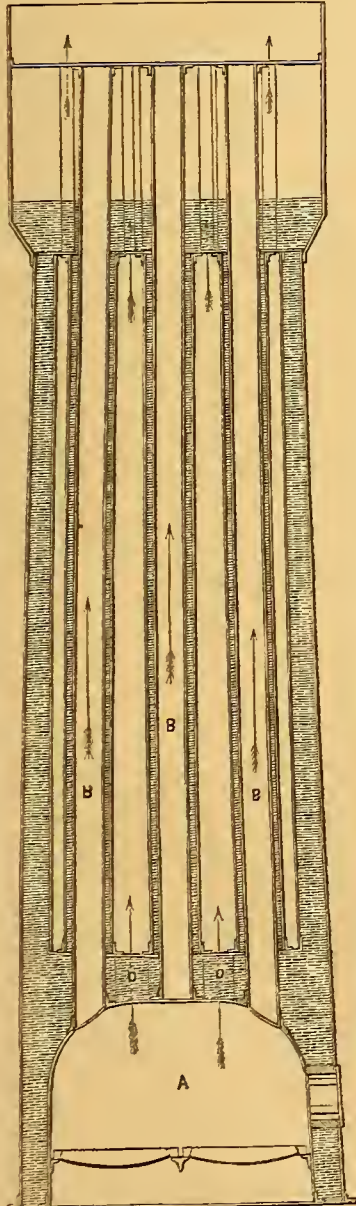

Fig. 34.

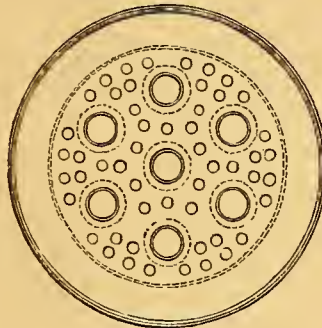

Fig. 35.



Fig. 38.

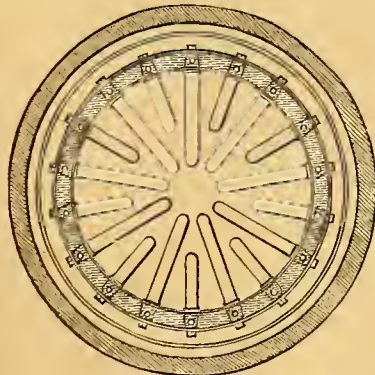

Fig. 36.

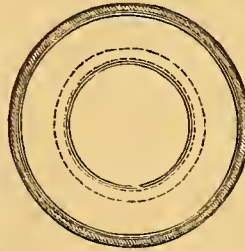
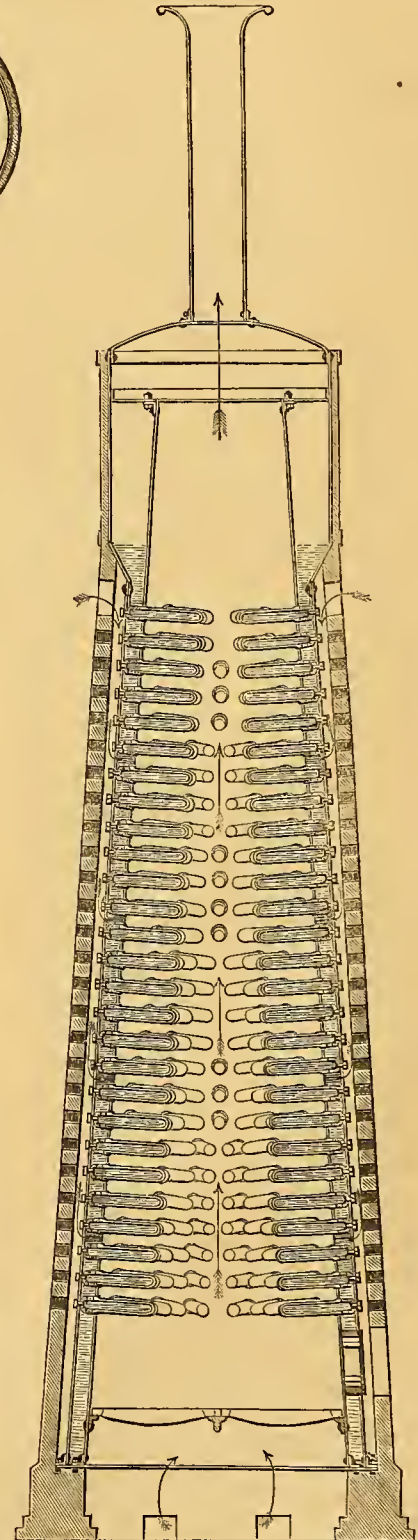

Fig. 37.



be needed for connecting the inner to the outer plate, it is intended to put one of the tubular stays, unless there should not be room for the projecting end. Figs. 36, 37, and 38, show another modification of the chimney boiler.

In this case the boiler has a clear passage to the external air at the top. It is circular in form, for greater strength, with an enlargement of the top, for steam room. To absorb heat from the flame and gases

which pass upward from the fire, the interior of the boiler is studded with tubular stays, so arranged as to bring the greatest amount of fire surface in contact with the flame, previous to its reaching the top of the boiler. This chimney boiler may be made square or oblong in its cross section; in which case the tubular stay may be used for increasing the fire surface; or, if necessary, the whole interior may be filled with cross tubes filled with water. In like manner the boiler, if of circular form, may be filled with cross pipes, disposed as may be most convenient for accomplishing the desired end. The chimney boiler is intended to be put together with bolts at the bottom, so that the interior may be taken out, if necessary, for repairs, or for clearing the interior surface from mud, &c. In the foregoing description of various forms of boiler, it will be manifest that an effort is made to apply the main portion of the heat to the external surfaces of tubes filled with water, instead of allowing the flame and gases to pass through small tubes, as is now generally used in locomotive as well as in marine boilers. It is very obvious that the more combustible gases evolved by the fire are kept in connection, the greater the chances of active combustion; whereas, by a very simple experiment, it will be found that combustion cannot be kept up to any great extent in a small tube, say from $1\frac{1}{2}$ to $2\frac{1}{2}$ inches diameter, except for two or three feet after the flame first enters from the fireplace. Beyond four or five feet, it is very doubtful whether it is worth while to carry the dead weight of tubes which are now used in the boilers of locomotive engines. By putting water inside the tubes, instead of around them, the mass of combustible gases are connected together by being distributed between the tubes, and thereby a better combustion takes place, which may be to a great extent improved by letting in atmospheric air into the fire-box, above the fire and amongst the tubes. Figs. 14 and 18 show a mode of putting on the hack sheet of the fire-box with screw-bolts and planed surfaces, or packed joints, so that it may be taken off at pleasure, by taking out the stay-bolts, giving greater facility for repairs and cleaning, whilst it permits the entire box to be taken out as soon as the stays. The series of small flues leading to the smoke-chamber are removed whenever these flues are used. The section of a tube below (fig. 27), shows a mode of protecting the upper surfaces of the tubes or other portions of the boiler which contain water, in which, from the great quantity of steam bubbles which may be thrown against these surfaces, there is danger of the water being driven away from them, causing these portions to be thereby burnt. To remedy this evil, the patentee places in the upper portion of each tube containing water, or at any other point where the same difficulty is likely to arise, a thin metal shield, curved in such a manner, and fitting so closely, as to intercept a great portion of the ascending steam, and leading it off towards the end of the water tube; or in the other portions of the boiler not tubular, away from the points of fire surface where danger might be apprehended by the water being driven away. By extending these shields through the entire length of the water tube, and through to the front tube sheet at the smoke-box, and by perforating the curved surface of the shield with holes, the steam will be discharged in rapid currents upwards, and between the series of flues leading from the fire-hox to the smoke-hox, which current will tend in a great degree to keep the flues just mentioned from being coated with mud or other incrustations.

Claims:—1st. Extending the fire-hox into the boiler in the manner hereinbefore in this specification, and by the said drawings, substantially described.

2d. In connection with such extension, the placing in the fire-box, and extension thereof, a series of horizontal, vertical, or diagonal tubes containing water, and either using the ordinary flues much shortened, thereby saving useless weight, leading from the fire-box to the smoke-chamber, or not, as may be deemed best, arranging the parts in the manner described, or in any other manner substantially the same as hereinbefore and in the said drawings described.

3d. Using and adapting the "teats," well known to boiler-makers, in such manner as to form tubular stays of cast or wrought-iron, or any other metal, for obtaining fire surface in the fire-box, or any other part of a steam-boiler, and at the same time making a secure connection (easily removed) between the inner and outer plates of boiler, as substantially hereinbefore described.

4th. Applying tubes of any given diameter, filled with water, above the fire in the fire-box of locomotive or other boilers now in use, and as they are now generally made, substantially as hereinbefore described.

5th. The use of return flues leading through the horizontal water pipes, as described in the marine boiler, as well as in the inner flue leading through the water tubes of locomotive boilers, to carry off a portion of the gases to the smoke-chamber, so as to present a double heating surface to the water contained in the water tubes, whether these flues are made to pass through the whole length of water tube or not, and made so as to receive the gases at any point throughout the whole length of water, substantially as described.

6th. The construction of the chimney boiler substantially as described, including the various modes of obtaining fire surface by the use of vertical water pipes, with or without inside flues through them, or by filling the interior chamber above the fire with "teats," serving the double purpose of giving fire surface and making a secure stay, or with cross pipes either in connection with the short flues at top of boiler or not.

7th. In connection with the extension of the fire-hox into the body of the boiler, the introduction of metal or clay pipes, for the purpose of heating the fresh supply of atmospheric air that may be introduced into the fire-box, and for distributing this air amongst the combustible gases evolved from the fire, so as to cause a better consumption of the fuel, and a consequent consumption of the smoke where coal is used, either in locomotives or stationary engines.

By forming a locomotive boiler with the prolonged fire-hox, advantage may be taken to indent the under side of boiler so as to leave the axle clear, whilst the centre of gravity of the engine is lowered in a corresponding degree; this being prevented in the usual form of boiler, on account of the tubes being in the way of such indentation.

LOCOMOTIVE ENGINES.

W. STUBBS AND J. I. GRYLLS, *Llanelly*.—Enrolled December 2, 1846.

Messrs. Stuhbs and Grylls' invention relates, first, to a mode of constructing locomotive boilers with two tubes, and in such manner as to

Fig. 1.

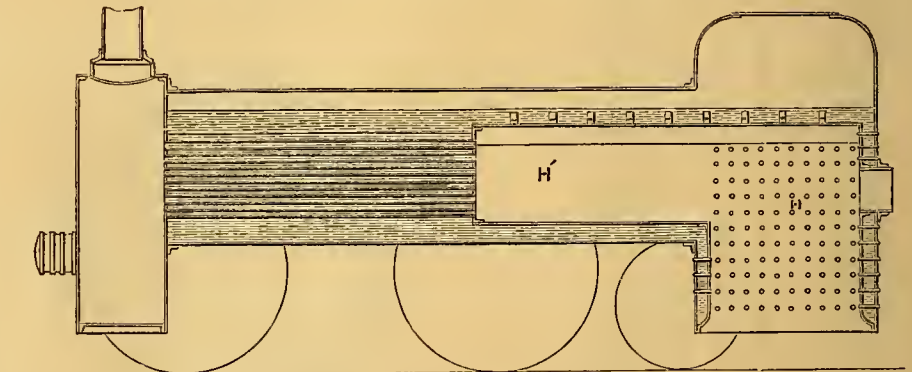

allow of introducing the wheel axle, and to a plan for communicating the steam power to the driving wheels by a double-piston cylinder, on the principle first introduced by Mr. Bodmer. The second head, which we shall more particularly notice, is illustrated by fig. 1 of our engravings. In that figure, the two cylinders are placed underneath the boiler. In this engine, four of the wheels are connected by side rods with the cross-heads of the two cylinders, and in such manner that each cylinder drives two wheels, each cylinder moving a cross-head, and each cross-head, by two connecting-rods, moving the wheels. H is the fire-box, and H' is a tube or continuation of the fire-box. This fire-hox differs from those at present in use, inasmuch as the part, H', projects into the cylindrical part of the boiler, two, three, or more feet, as may be necessary. The object of this improvement is to remove the ends of the small flue-tubes to a distance from the direct action of the fire, and by such means a saving will be effected in their durability. The arrangement of cylinders given under this head will be found very convenient, and, at the same time, it will tend to prevent side oscillation in the locomotive engine.

In fig. 2, the boiler and tube of the engine shown is very similar to that described in respect to fig. 1, with this important difference, that the boiler and tube are recessed underneath, to admit of the lowering of the boiler, and yet allow of employing wheels of large dimensions; the diameter of the wheels shown is nine feet, but this part of the invention can be used with driving wheels of other diameters, for the purpose of

reducing or bringing down the centre of gravity. *n* is the fire-box, and tube, *n'*; *i* is the recess, and *o* is the axle of the driving wheel.

Another head relates to driving engines by means of eccentrics fitted with antifriction rollers, as a substitute for the ordinary cranks.

Fig. 2.

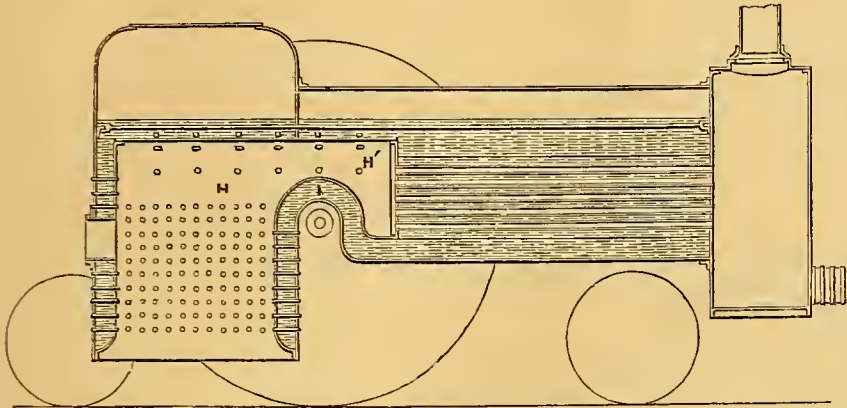

A mode of building broad-gauge engine-boilers with double bodies, and plans of six and eight-wheeled carriages, for producing superior steadiness, sum up the specification.

LOCOMOTIVE ENGINES AND RAILWAY AXLES.

J. E. M'CONNELL, *Wolverton*.—Enrolled February 28, 1852.

The portions of Mr. M'Connell's invention which we have here selected for illustration, relate, first, to the supplying atmospheric air to the fuel or flame in the fire-box of the boilers of locomotive engines by means of tubular stays, it being a well-known fact, that a very large proportion of the gases evolved or given out from the coke is not burned for the want of a sufficient supply of oxygen. Much of the gas so evolved being carbonic oxide, which is given out from the coke, and only requires to be mixed with about 1-5th of its whole bulk of atmospheric air to produce perfect combustion, being without this incombustible. The air necessary for this purpose is supplied to the flame by means of tubular stays, *a*, figs. 1 and 2, screwed into the inner and outer plates, forming the water-space of the boiler, and placed at convenient distances between

Fig. 1.

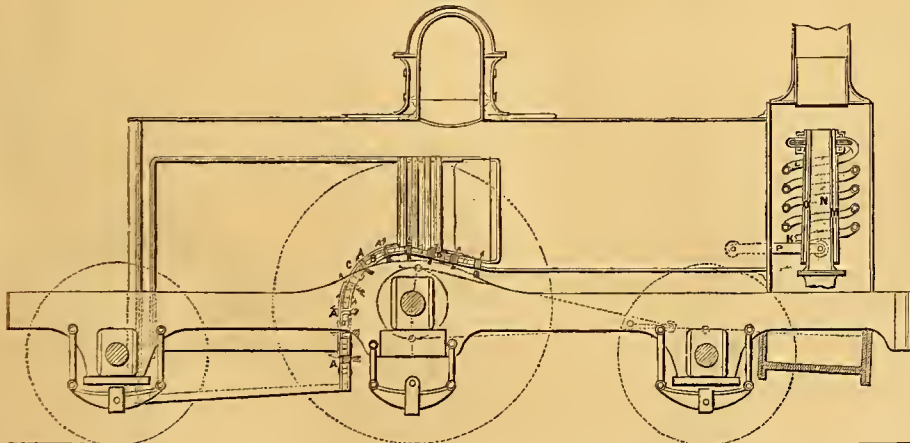

the other solid stays, *b*. The quantity of air to be admitted through these several stays may be controlled by caps or valves over each, to be acted on at pleasure by the engine-driver. Another of Mr. M'Connell's improvements consists in a transverse indentation of the water-space of the bottom of the boiler, forming as it were a bridge wall, thereby allowing the centre of gravity of the boiler to be lowered. The extending the fire-box into the body of the boiler, so as to shorten the tubes (as shown in the figure), has been patented by Mr. Joseph Harrison, so that Mr. M'Connell's invention is confined to indenting that portion of the boiler immediately over the axles, so as to allow the weight and centre of

gravity to be lowered in proportion to the depth of such indentation, at the same time doing no injury to the boiler, the line or curve of indentation being shown by the letter *a*.

Another of Mr. M'Connell's improvements consists in adapting a

peculiar form of apparatus to the smoke-box of locomotive engines, for heating the water before it enters the boiler by means of the heated gases passing through the smoke-box, and the exhaust steam, before it leaves the blast-pipe. The water is forced into, and passes up the coils of pipe, *κ*, fig. 1, and enters the annular space, *ο, m*, which is around the blast-pipe, *κ*, passing down the annular casing, and into the boiler, through the pipe, *p*. By this arrangement a double object is effected; for, by forcing the water first through the coils of pipe, a portion of the heat from the heated gases passing through the smoke-box is taken up; and as the water passes down the annular space around the blast-pipe, another portion of heat from the exhaust steam of the engines is taken up, thereby saving much of the heat that now passes into the atmosphere, and reducing the consumption of coke necessary to maintain the power of the engine.

Under these heads the patentee claims:—

The supplying atmospheric air to the fuel or flame, after it has left the surface of the fire, by means of tubular stays inserted in, and adapted to, the fire-box, as described. The indenting of a locomotive boiler immediately over the crank axle, substantially as described. The adaptation of an apparatus so placed in the smoke-box of a locomotive boiler for heating the water before it enters the boiler, both by the heated gases that pass through the smoke-box, as well as by the exhaust steam, as described.

Fig. 2.

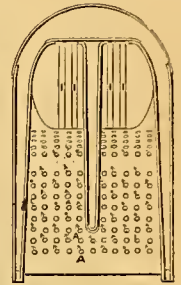

BREECH-LOADING FIRE-ARMS.

JOSEPH NEEDHAM, *Piccadilly*.

Our illustrative figures will show that Mr. Needham's ingenious invention is founded on the principle of the "Prussian Needle Gun;" but the ignition needle which he employs, is a species of stout striking spindle. Fig. 1 is a side elevation of the lock portion of a rifle, and fig. 2 is a corresponding longitudinal section. Figs. 3 and 4 are side and end views of the duplex cam, which works the needle action in loading and unloading. *a* is the barrel of the rifle, which is fitted to the stock, *b*, in the ordinary way, by the tail-piece, *c*, and slotted eyes, *d*. The breech end of the barrel is half cut away at its upper side, for a short distance; and into this portion of the barrel is fitted the short gun-metal tube, *e*, which turns on the fixed pin, *f*, in the end of the barrel. The end of the tube, *e*, has a square-threaded screw cut upon it, which takes into a similar internal screw in the cap, *c*. This cap has a handle, *h*, formed upon it, for the purpose of turning it when required. A small double-crown cam, *i*, is screwed into the inside of the cap, and serves to push back the needle, *j*, as will be hereafter described. The needle is simply a short piece of steel wire, which fits into a socket, *k*, on the end of the notched spindle or pin, *l*, and secured in its socket by a small pinching screw. A helical spring, *m*, embraces the spindle, *l*, and gives it the impelling force necessary for the explosion of the cartridge, *n*. A feather, *o*, is formed on each side of the socket, *k*, and these wings retain the spindle, the proper side up, by sliding in the slots in the interior of the bore of the tube, which contains the needle apparatus. *p* is the "sear," and *q* the "sear spring," both of which are attached to the moveable tube, *e*. The sear is pressed by its spring into a notch in the end of the spindle when

the latter is pushed back, and retains it until released by the action of the trigger, *r*, which tends to draw down the "sear;" thereby causing it to turn on its fixed centre, *s*, and release the spindle, which is immediately impelled forwards by the pressure of the helix against the socket,

k. The cartridges are each fitted with a gutta percha capsule, *t*, having a short tail, *u*, formed upon it. The interior of the capsule is fitted with a thin metal disc, slightly dished, and the cavity or cup thereby formed is

to fig. 2, it will be seen that the end of the cap, *o*, when the tube, *e*, is down, projects a slight distance out the hore of the barrel, but, by means of the screw-threads in the cap, the partial turning of the handle, *h*, causes the cap to recede a short distance, sufficient to clear it from the end of the hore. The tube, *e*, is now free to be turned back on its centre, *f*, until it assumes the position shown in dotted lines in fig. 1. The cartridge is then introduced into the breech of the gun, into which it fits tightly by the gutta percha capsule, *t*; the tag, *u*, is left out, as shown, and the tube, *e*, is shut down when the handle, *h*, is pressed into its place, and retained by the spring-catch, *w*. The replacing of the handle into its original position causes the end of the cap, *g*, to be forced tightly into the breech of the harrel, at the same time bringing the inclines of the double cam, *i*, into such a position as to correspond with the wings, *o*, on the needle socket. The gun is now ready for firing, which is effected in the ordinary manner, by drawing the trigger; the helical spring then forces the needle into the capsule, which explodes the fulminating powder contained in the small metal disc. The tube, *e*, is then opened, as before described, and the capsule removed. In order that the turning of the screw-cap may leave no space between the junction edges, they are cut obliquely, to correspond with the screw-thread. By this means, when the end of the cap is forced into the hreech of the harrel, the oblique junction edges of the cap and tube leave no space for the entrance of dirt into the screw.

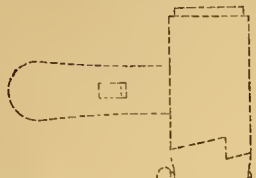

Fig. 1.

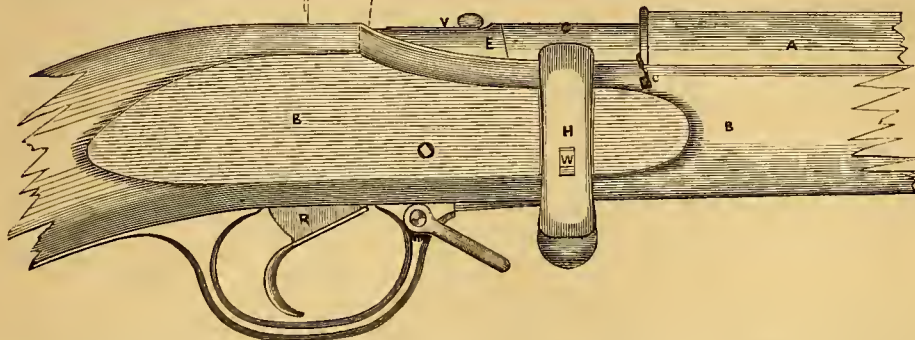

Fig. 2.

filled with fulminating powder. A piece is cut out of the bottom of the capsule, so as to leave the fulminating powder free to be acted upon by the needle. This capsule, by being made to fit tightly into the

arm, more especially with the view of preventing any gaseous escape on firing; but what we have already detailed will be sufficient to point out the general nature and value of the improvements.

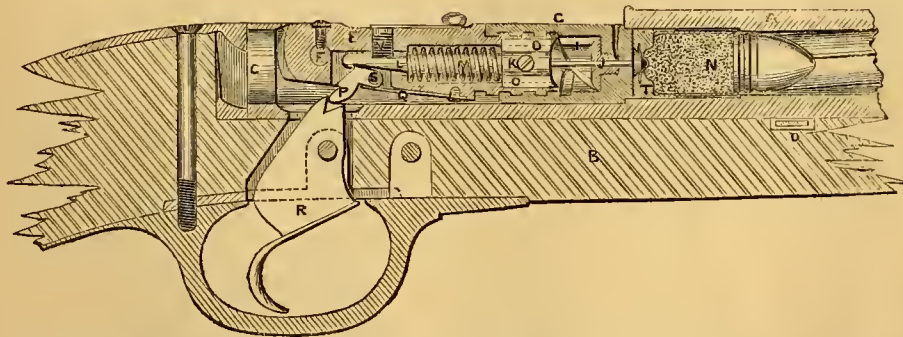

Fig. 3.

Fig. 4.

breech of the harrel, prevents the escape of the gases on firing, which would otherwise take place. After each shot the capsule is left in the breech, and must be removed therefrom by the small tag or tail, *u*, before another cartridge can be introduced.

To guard against accidents, a small safety bolt, *v*, is fitted to the upper side of the tube, *e*. The lower portion of this bolt is cut away on one side, and takes into a notch on the upper surface of the spindle when in action; but, by simply pushing the small arm from one notch to another on the surface of the tube, the peculiar shape

of the bottom of the bolt unlocks the end of the spindle, and allows it to be released by the trigger.

The handle, *h*, of the cap, *o*, fits into a recess or groove in the side of the stock, being almost flush therewith; it is retained in this position by a small spring-catch, *w*, fitted into the side of the stock. This catch is so arranged as to release the handle when a slight pull is applied; but, nevertheless, holds it sufficiently tight to prevent it from turning accidentally. To effect the loading of the gun, the handle, *h*, is turned over, and with it the cap, *g*, to the extent of nearly half a revolution; this brings round the double cam, *i*, to the same extent, and its inclined edges pressing against the ends of the wings, *o*, on the socket, *k*, force back the needle until the end of the spindle, *l*, is caught and retained by the sear. On reference

REGISTERED DESIGNS.

WATER-SPACE DOOR-FRAMES FOR FURNACES.

Registered for Mr. JOHN HIGGINS, Primrose Iron-Works, Oldham.

This is an application of the well-known principle of securing the non-conduction of heat by a cool water-space, as adopted in smiths' and furnace-tuyeres, anvils, and, latterly, in the side-plates of the puddling furnace, as patented by Mr. Jones of Bilstou. Mr. Higgins has represented his con-

trivance under several forms, as applied to single and double flue, and Butterly or waggon boilers. Our engraving represents the hollow door-frame for a single flue boiler, the cover, or side-plate, being removed to show the water-space. A pipe is cast on each side, opening into the hollow of the frame, and the boiler feed-water enters by one of these pipes, and, after flowing through the enclosed space, passes off by the other to the boiler. The feed is thus highly heated before it enters the boiler, and, whilst it economises the furnace-heat, it relieves the fireman from the oppression which he meets with at present, where single solid frames only are used.



CORRESPONDENCE.

DUPLIX ELLIPTIC ROTATORY ENGINE.

As I have been much interested by the description of Messrs. Wright & Hyatt's beautiful invention, I have taken the liberty of enclosing a sketch of a mode of avoiding the dead points of the action, which, I think, would be an improvement. The annexed figure is a transverse section

of the engine so arranged. It has two pistons, A, B, crossing each other at right angles, and passing through the main shaft, c, which is expanded into a cylinder at that part. Then the openings of the ports being narrow, and carried a sufficient distance round the cylinder on each side, it appears that we should have an engine of nearly uniform action, which, if I judge rightly, would combine nearly the power of two engines, (one

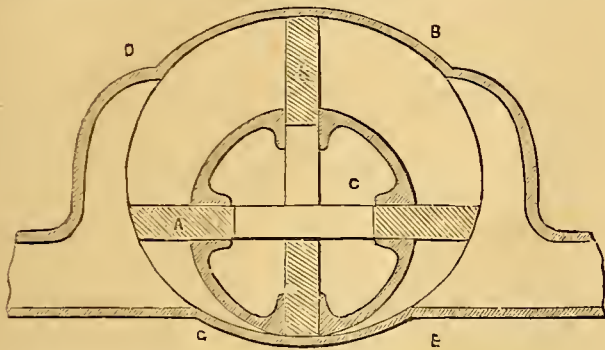

of the pistons constantly passing through the effective space, D F, E G, whilst the other is neutral, the steam being on both sides of it,) and with little more than the weight and friction of one, and requiring no fly-wheel. The bearings of the pistons are lengthened by passing them through the shaft, and the steam passages being very long, are made proportionally narrow, so as to favour the retention of the true ellipticity of the cylinder. The shaft is to be countersunk into the cylinder ends, and kept tight by a narrow annular packing of Schiele's antifriction curve. From some trials which I have made, it seems that the eccentric piston will fit in any ellipse between the proportions laid down by Messrs. Wright & Hyatt, and a true circle—the shaft being correspondingly shifted until it coincides at last with the centre of the circle—the power similarly decreasing to nil. The pistons can, therefore, be made of the requisite thickness for strength.

GEO. P. RENSHAW.

Nottingham, January, 1853.

COMPOUND SEWERS.

I beg to submit to you a proposed section for a main sewer, which, it appears to me, may be introduced in some places with much advantage. I am not aware that a section of the particular shape has been noticed before. It is intended, you will observe, to combine the benefits to be derived from the common pipe drain, along with the superiority, in other respects, of the large brick sewer. The base is of stone, and the stout brick-work, springing up from this foundation, leaves a central tapered sewage passage, terminating in side ledges for sustaining, on one side a gas, and on the other a water-main. Above this level, the structure is 1½ bricks thick, and the crown is one brick.

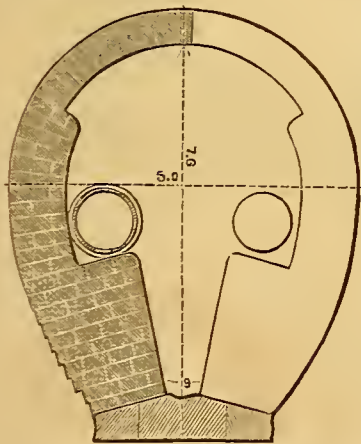

Perhaps it is not worth while to occupy your space by attempting any lengthened description of this section, as the points in its favour, and also against it, will be readily seen by all practical men.

E.

Liverpool, March, 1853.

REPORT OF THE COMMISSIONERS FOR THE EXHIBITION OF 1851, AND SCHOOLS OF DESIGN.

Ideas, thought, observation, taste, and other similar themes, have been copiously written upon, and made the subject of popular essays, by men of the highest reputation and talent; yet, notwithstanding all their excellence, if a clear and comprehensible definition of either of them be

called for, no one can give it in such a direct manner as to show them to be thoroughly understood. In like manner, design seems to be an *ignis fatuus*, eluding an exposition which would enable schools or institutions to be made certain and fruitful sources of skill and taste in the ornamental, decorative, and fine arts. In your review of the Second Report of the Commissioners for the Exhibition of 1851, you remark that, "It is obvious that, to meet this need of the age, some definite system of proceeding must be struck out;" and I presume, as the Government School of Design has been given up, that some part of the balance from the Great Exhibition will be expended by the Commissioners, or through their influence, on the grand site of 150 acres, "secured for the benefit of the arts and sciences cultivated by us." "Mr. Warrington Smythe, Professor Edward Forbes, and Dr. Playfair," show, in their lectures, "the immense expenditure (of the School of Design), to no purpose, of time, and money, and talent," &c.; but in any future institutions connected with the Royal Academy of Art, or schools that may be organized by parochial authorities or otherwise, as proposed by the "Department of Practical Art as the mode of proceeding for establishing classes or schools for elementary instruction in art," can a better result be expected?

"The blunders that were committed by persons attempting to achieve things which the simplest knowledge would have told them were impossible to be accomplished." So say the Commissioners. Notwithstanding which, have those blunders, and the immense expenditure that attended them, disclosed a definite system of the art of design, that can now be taught in classes and schools, as clearly as addition, subtraction, multiplication, and division? Certainly not; and as I told the meeting at the Royal Institution, at Manchester, in 1838 (which took place for the formation of a School of Design), that the first step should be to ascertain and recognize the principles and practice of design, or any attempt at satisfactory results from such schools would be as vain as to set up colleges for the general production of Homers, Miltons, and Shakespeares.

The third section of the circular of the Department of Practical Art details "the duties of the masters, with a list of the articles and examples requisite for teaching," but they by no means constitute the requisite definite system. Their circular says, "My lords already have fully recognized the great importance of elementary drawing to all classes of the community," &c., &c. The qualifications of "masters appointed to elementary drawing classes are expected to be acquainted with the works used by the Department of Practical Art on geometry and perspective," &c. Now, as so much stress is laid upon elementary drawing, for cultivating the taste of the community at large, as well as the artisan and designer; and they justly name *geometry* and *perspective*, as the bases "for free-hand drawing of the solid forms used in the elementary schools,"—how is it that these authorities for the guidance of national skill and taste persist in teaching geometry and perspective, and the drawing of solid forms, in a manner at variance with the laws of nature, and the optical effect of every student's eye; when, for many years, the Daguerreotype and Talbotype, or sun drawings, "have proved how far the pencil of the draughtsman has been from the truth," as Arago says, and substantiated the natural principles of perspective and visual or optical geometry, previously published by me under the title of 'The Science of Vision, or Natural Perspective'?

While this system of perverting the ideas and judgment of students and the public is persisted in, and masters are bound to it by government authorities, can excellence, or a general suffusion of skilful designing, ever be established on false elementary principles? The system imperatively necessary "to meet the need of the age," can only be developed upon an application of the principles of abstract geometry to the various practical purposes of trade, ornament, and art; and upon a sound knowledge of the eyesight, and its *modus operandi*, in producing upon the mind those effects or optical forms which are imprinted, like sun drawings, in the eye, and are the only correct and legitimate outlines for the drawing of solid forms.

The eye has always been the emblem of wisdom; and it is only by a better and more universal knowledge of optics and natural perspective, that a perfect comprehension of light, and shade, and colour, as well as correct outline, can be acquired; and the *definite system*, so much desired, must still remain a mystery until the correct elementary principles are clearly taught and instilled into the mind and practice of designers and artists generally.

It is not generally known, that what is called and taught as perspective, is not perspective at all, it having been treated mathematically, while it ought to have been treated optically, as the outlines in the representation of solid forms, to be correct, ought to be the effects of the eye of the artist, or delineator. Nothing can show the deficiency of science and art more clearly than the sun drawings, which are denounced by the public, and by art and science, as out of drawing, *i.e.*, incorrect, because those

delineations CONVERGE the *perpendicular* as well as the *horizontal lines* of buildings, &c.

From the public not having been taught to understand this effect of every one's eyesight, and the so-called art of perspective having established a practice in art which has familiarized the public eye to a system of drawing, omitting an unavoidable effect on the sight of every observer, sun drawings, made by an instrument constructed on the principle of the human eyesight, for want of knowing the true optical principles and effect, are regarded as distortions of nature. Till this blindness is removed, a definite system, and a sure practice of art, cannot be established. The subject is one that is very simple, but it can only be known by a short practical study of the eye, and the elementary principles of the art. A description of it is insufficient for the reader to understand it. Ainsworth's definition in his dictionary is brief and correct, viz., "*La pars optices que res objectas oculis aliter quam re ipsa sunt representat*,"—"that part of optics by which things seen by the eye, are represented different to the thing itself"—because the eye alters the geometrical shape, and gives it an optical outline, which is the perspective and object of art truly to delineate. Any one knowing the elementary rules of true perspective drawing can produce these effects, which certainly establishes a standard of taste, both for the draughtsman and the public, as no difference of opinion can exist as to correctness, when the truth of the representation can be demonstrated optically.

As I am the author of the 'Science of Vision, or Natural Perspective,' it may be imagined that I have a partiality for my own views on the subject; but my theory having stood the test of the severest investigation by men eminently qualified to detect any error or deficiency, and the subsequent discovery of photographic drawing having introduced a new character into the fine arts (which can only be demonstrated to be correct by my theory), it must be evident that I am justified in denouncing the common practice of teaching spurious perspective, and am desirous of pointing out a definite system for the art of design. There is one thing which has militated seriously against the adoption of the true principles of perspective, viz., that art has been misguided by the theories of science. Science knows now that art has been wrong; but as science uses perspective in astronomy, &c., it knows it is wrong too; and that, if science attempted to rectify art, it would have to rectify itself; and so the progress of improvement is slow, as those authorities who are expected by the public to advance knowledge, as usual, are silent, and the truth awaits its own recommendation from a future generation.

ARTHUR PARSEY.

London, March, 1853.

P.S.—The Royal Academy has not had a Professor of Perspective for many years. The celebrated Turner, R.A., was the Professor, and the last time he lectured on the subject, he left off in the middle of his lecture, with the declaration "that he had puzzled himself, was sure he had puzzled the students, and that he should give it up." Since which time our National School of Art, which is considered the standard, has been without any guide on the great, first, and only principles of pictorial art and design, as the professorship has been suspended for many years. My offer to deliver a course of lectures in the Royal Academy was respectfully declined, although the late John Constable, R.A., William Etty, R.A., and R. R. Rainagle, R.A., after attending my lectures, gave me testimonials of the soundness and perfection of my system.

TRANSPORT OF CLEOPATRA'S NEEDLE.

I observe, in your March number, a proposal to transport Cleopatra's Needle from Egypt to England, by means of a fir raft, or caisson, and I am induced to trouble you with the present communication, because the proposal involves a great principle, which, if carried out, would effect an important change in the timber trade, and would greatly tend to cheapen timber, besides having various other good effects. The principle to which I allude is that of conveying certain kinds of timber across the seas in rafts, formed somewhat like ordinary sailing vessels, instead of in ships. I suggested the adoption of this system in the *Shipping Gazette*, of 28th December, 1850. Mr. Elmes' proposal is at least, on his part, a confirmation of its practicability.

Instead of using a mass of stone to ballast and stiffen the raft, or log

ship, hardwood might be placed in the bottom. And perhaps it would be well to adopt the custom of merchant ships, that of laying the timber parallel to the keel, so that three or four iron hoops, or bars, might be placed round the mass to bind the whole tightly together—the spaces on the sides of the raft between these bars being filled up with deals, which, if nailed at the ends only, would not be much damaged, thus making an unbroken and smooth surface along the raft's sides. The bow and stern would also have to be sheathed with deals in the same manner, and so lessen the friction of the water.

Of course the raft would approach the shape of a ship as much as possible, and might be made of any dimensions. It should be masted and roughly rigged, like an ordinary ship. As timber is of little value in the countries where it is grown, the masts might be each in one piece, and they would sell for nearly their full value after arrival at their destination. A raft formed thus would contain more timber than a ship of the same dimensions. By using bars, instead of bolting the timber together, little or none of the timber would be damaged.

The advantages gained over a ship would be, that the whole hire of the ship would be saved; which would be so much the greater, as freights have advanced 30 per cent. on last year's quotations. The only offset against this is, the first expense of the iron bars and outfit of the raft, and their carriage to the port of loading. The bars and outfit, however, after having been stripped from the raft, would again serve several times for the same purpose.

Sunderland, March, 1853.

X. Y. Z.

REVIEWS OF NEW BOOKS.

THE PRACTICAL DRAUGHTSMAN'S BOOK OF INDUSTRIAL DESIGN: Forming a Complete Course of Mechanical Engineering and Architectural Drawing.

By William Johnson, Assoc. Inst. C. E. Parts 1, 2, and 3. 4to. Plates and Wood Engravings. Longman, Brown, Green, & Longmans, London. 1853.

(Illustrated by Plate 122.)

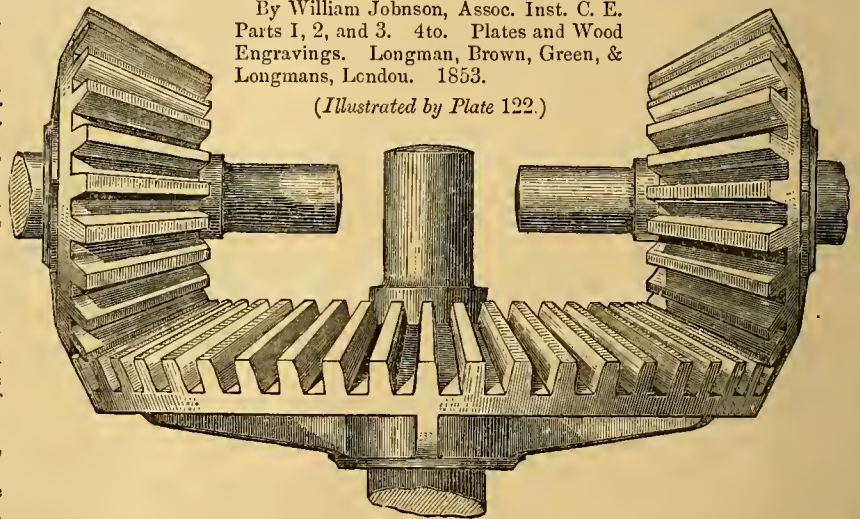

The mass of inquiries for practical text-books, and plain rudimentary guides to scientific information, which so constantly accumulate on our desk, strongly indicate the difficulties of the anxious student, in his attempts to combine that knowledge and thought which are at once the delight and the prerogative of man. Every week brings us some task of this nature, and scarce a day passes over our head without some melancholy illustrations of that misapplied ingenuity, and consequent waste of intellectual force, which is usually traceable to the lack of a little consideration over a plain-speaking textual guide. It is true that the student cannot reasonably complain of a want of generally instructive matter. The Mechanic's Institution or library of every little town usually furnishes that. But there is reason for lamenting the practically inaccessible nature of the great bulk of specific details, which every young inquirer must primarily endeavour to master. Sound works are indeed before him, but they are too often enveloped in mystery, and mixed up with irrelevant matter, which stops the reader at the very outset of his researches. Connected as we are with what are pre-eminently industrial pursuits, we cannot but welcome the coming of any honestly-disposed work, bearing such a title as we have quoted above; for its aim is, at any rate, laudable, and it proposes to fill a void which has long been felt as a weighty evil. The *Practical Draughtsman's Book of*

Industrial Design, is founded upon the well-known work of MM. Armengaud, and is brought out here with their concurrence. Its preface tells us that—

"It is intended to furnish gradually developed lessons in geometrical drawing, applied directly to the various branches of the industrial arts: comprehending linear design proper; isometrical perspective, or the study of projections; the drawing of toothed wheels and eccentrics; with shadowing and colouring; oblique projections; and the study of parallel and exact perspective; each division being accompanied by special applications to the extensive ranges of mechanics, architecture, foundry-works, carpentry, joinery, metal manufactures generally, hydraulics, the construction of steam-engines, and mill-work."

It is to be comprised within nine divisions, appropriated to the different branches of industrial design. These include linear drawing—the geometrical representation of objects, or the study of projections—the conventional colours and tints for the expression of sectional details—curves, as helices and spirals—gearing and patterns—shading and colouring—perspective—and an appendix on drawing instruments.

Our composite plate, 122, presents a series of examples of the figures which have already appeared in the three parts of the work now published; and we quote the following descriptive matter from the text of the work:—

"To draw a stone balustrade of an open-work pattern, composed of circular and straight ribbons interlaced, figs. J and 10.—Construct the rectangle, A, B, C, D, its corners being the centres of some of the required circles, which may accordingly be drawn, with given radii, as A, B, C, D; after bisecting AB in E, and drawing the vertical E O, make EF equal to EA, and with F as a centre, draw the circle having the radius, F G, equal to A B, drawing also the equal circles at C, B, E, &c. Draw verticals, such as g h, tangents to each of the circles, which will complete the lines required for the part of the pattern, J, to the left. The rosettes to the right are formed by concentric circles of given radii, as E, C, E, F. The duplex, fig. J, may be supposed to represent the pattern on the opposite sides of a stone balustrade. Where straight lines are run into parts of circles, the student must be careful to make them join well, as the beauty of the drawing depends greatly on this point. It is better to ink in the circles first, as it is practically easier to draw a straight up to a circle, than to draw a circle to suit a straight line.

"To draw a pattern for an embossed plate or casting, composed of regular figures combined in squares, figs. K and 11.—Two squares being given, as ABCD and EFGH, concentric, but with the diagonals of one parallel to the sides of the other, draw first the square, a b c d, and next the inner and concentric one, e f g h. The sides of the latter being cut by the diagonals, A C and B D, in the points, i, j, k, l, through these draw parallels to the sides of the square, A B C D, and finally, with the centre, o, describe a small circle, the diameter of which is equal to the width of the indented crosses, the sides of these being drawn tangent to this circle. Thus are obtained all the lines necessary to delineate this pattern; the relief and intaglio portions are contrasted by the latter being shaded."

Fig. C represents the beautiful curve of the oval of five centres in its application to the construction of bridges; and the objects represented in figs. D and D', are an example of the application of the parabolic curve.

"They are called *Parabolic Mirrors*, and are employed in philosophical researches. The angles of incidence of the vectors, a b, a c, a d, are equal to the angles of reflection of the parallels, b b', c c', d d'. It follows from this property, that if, in the focus, a, of one mirror, b f, the flame of a lamp, or some incandescent body be placed, and in the focus, a', of the opposite mirror, b' f', a piece of charcoal or tinder, the latter will be ignited, though the two foci may be at a considerable distance apart; for all the rays of calorific falling on the mirror, b f, are reflected from it in parallel lines, and are again collected by the other mirror, b' f', and concentrated at its focus, a'."

Fig. B practically illustrates the *Ionic Volute*, and affords a lesson as well upon shading, and the effect of shadows. The remaining figures furnish an elevation, plan, and longitudinal section of a *Spherical joint*, for connecting pipes where play is required without interfering with the fluid passage. These figures, being selected from the purely elementary portion of the work, are necessarily amongst the most unattractive of its contents, which, however, already present some features of increasing interest. For example, Plate 10, in the third part, contains a large sheet, printed in eight colours, to illustrate the "application of colour and conventional tints," forming a peculiarly novel and valuable feature in works of this kind. We may add, that each number contains eight quarto pages of plates, executed with all the accuracy and beauty of finish for which the French are so celebrated; and to this array of illustrations is also added, examples of finished machine drawings. The meter, in the first part, may be particularly mentioned as an excellent specimen of accurate drawing and effective engraving.

PROCEEDINGS OF SCIENTIFIC SOCIETIES.

INSTITUTION OF CIVIL ENGINEERS.

DECEMBER 21, 1852.

This was the annual general meeting for the election of the officers of the Institution, and other general business. After reading the report of the retiring Council, the principal papers read during the past session were recapitulated and commented on, and the following premiums were presented:—

Telford Medals to Captain Mark Huiish, Colonel Sam. Colt, Messrs. Braithwaite Poole, Frederick Richard Window, Charles Coles Adley, Eugène Bourdon (Paris), Pierre Hippolyte Boutigny (d'Evrenx), and George Frederick White.

Council premiums of books to Messrs. John Baldry Redman (for the third time), William Thomas Doyne, William Bindon Blood, George Donaldson, Christopher Bagot Lane, and William Bridges Adams.

The resignation of Mr. J. Miller from the Council, in consequence of long-continued illness, was accepted with regret; and, at the ballot, the following members were declared to form the Council for the ensuing year:—James M. Rendel, *President*; I. K. Brunel, J. Locke, M.P., J. Simpson, and R. Stephenson, M.P., *Vice-Presidents*; G. P. Bidder, J. Cubitt, J. E. Errington, J. Fowler, C. H. Gregory, J. Hawkshaw, J. R. McClean, C. May, J. Penn, and J. S. Russell, *Members*; and T. Brassey and T. R. Crampton, *Associates*.

JANUARY 11, 1853.

"On the Nature and Properties of Timber, with Notices of several Methods, now in Use, for its Preservation from Decay," by Mr. H. Potter Burt.

JANUARY 18.

Discussion of Mr. Burt's paper "On the Preservation of Timber."

JANUARY 25.

After the termination of the discussion on Mr. Burt's paper, the President directed attention to the Dublin Exhibition, and Mr. Roney, who was present, solicited the members for contributions of exhibitable articles.

"On the Construction of Fire-Proof Buildings," by Mr. James Barrett.

In the lobby, one of Jennings' Sluice Valves was exhibited. The improvement was stated to consist in simplifying the construction, by casting the body and the faucet ends in one piece, thus avoiding the use of bolts, nuts, and joints. The slide was first fitted, and made to work properly on the body of the valve; it was then removed, and, with two gun-metal faces, was turned, ground, and accurately fitted. The slide, through which a small hole had been previously drilled, was again placed in the valve, the two faces were introduced, and all firmly bolted together. The joints of the faces, which were dovetailed to the body, were then made with lead, or with iron cement; the bolt was removed, the hole plugged, and the valve was completed, at considerable saving of time and cost. These valves were stated to have been extensively used under considerable pressures.

FEBRUARY 1.

"On the Pneumatics of Mines," by Mr. Joshua Richardson.

FEBRUARY 8.

Discussion on Mr. Richardson's paper.

FEBRUARY 15.

"On the Use of Heated Air as a Motive Power," by Mr. R. Cheverton.

FEBRUARY 22.

Discussion on Mr. Cheverton's paper.

MARCH 1.

"On the Increased Strength of Cast-Iron produced by the Use of Improved Coke," by Mr. William Fairbairn.

MARCH 8.

"Experimental Investigation of the Principles of Locomotive Boilers," by Mr. D. K. Clark.

MARCH 15.

Discussion on Mr. Clark's paper.

INSTITUTION OF MECHANICAL ENGINEERS.

ANNUAL GENERAL MEETING, BIRMINGHAM, JANUARY 26, 1853.

"On an Improved Railway Chair," by Mr. John M'Conochie, Wednesbury.

"On Iron, and some Improvements in its Manufacture," by Mr. J. D. M. Stirling.

"Description of Cugnot's Original Invention of the Locomotive Steam-Engine for Common Roads," by Mr. E. A. Cowper.

ROYAL SCOTTISH SOCIETY OF ARTS.

MONDAY, 13TH DECEMBER, 1852.

DAVID STEVENSON, ESQ., F.R.S.E., PRESIDENT, IN THE CHAIR.

The President delivered a short address on taking the chair: after which, at the request of the Council, William Swan, Esq., F.R.S.E., gave an exposition of eclipses, with an account of the remarkable phenomena observed at the total solar eclipses of 1842 and 1851.

JANUARY 10, 1853.

"On the Principle of Ascent from the Centre of Gravity," by Mr. John Campbell, of Carbrook.

"On the Cause of Upright Movement, or Ascent from the Centre of Gravity, illustrated by the Anti-Lunar Tide," by the same Author.

"On a Self-Acting Railway Signal," by Mr. Andrew Carrick, Glasgow.

The author stated that the signal consists of a hollow cast-iron column, fifteen feet high, having a circular orifice near the top, nine inches diameter. This orifice is obscured by a thin copper disc, six inches diameter, so that a circle of daylight is seen through the column during the day, and a bright circle is seen during dark by means of a lamp and reflector. A vertical rod, fixed to the locomotive engine, touches a lever at the signal column, and sets a pendulum in motion inside the column. The motion of the pendulum causes the disc to vibrate across the orifice, and indicates to the engine-driver that a train is ahead of him. The extent of the vibration will enable him to judge how far the said train may have run since it passed the signal-post. If the disc be at rest, no engine has passed within the

last fifteen minutes. The author's intention is, that such a signal should be placed near both ends of tunnels and curves, where the engine-driver cannot see far before him.

Some discussion arose in regard to this proposal, and several objections were stated—some of which resolved themselves into this, that the diameter of the disc was greatly too small to be seen at a proper distance. Others had reference to the shock which the lever would sustain by the stroke given by the engine while moving at a rapid rate; and others to the interference of the lever with the locomotive, should it be necessary to run backwards along the line.

JANUARY 24.

"On the Adaptation, to Every-day Practice, of the Capillary Tube Method of Preserving Vaccine Lymph," by W. Husband, M.D.

"On a Stop-Cock, with India-rubber Tube and Improved Action," by Mr. James Robb, Haddington.

"On an Elastic Self-Adjusting Castor," by the Same.

The Secretary called the attention of the Society to a notice in the proceedings of the American Association for the Advancement of Science, held in 1850, of a peculiar property of a mixture of lard and rosin, which, in place of being harder than lard, is much softer, and, at ordinary temperatures, remains in a semi-fluid state. It is stated to be an excellent substance for applying to pistons, and does not, like lard, corrode brass-work. The best mixture is said to be three parts of lard to one of powdered rosin, *by weight*, stirred together under a gentle heat.

FEBRUARY 28.

"On the Initial Velocity of Shot—Range at Different Velocities—Eccentric Shot,"—by George Lees, LL.D.

"On a New Process of Stereotype Moulds, with Notices of the History and Results of the Process of Stereotyping," by Daniel Wilson, LL.D.

Mr. Dixon Vallance, Greenshields, exhibited, in action, a working model of his Condensed Water-Pressure Wheel, by which he endeavoured to show its superiority to the Overshot Water-Wheel, the water being applied to it in both ways.

SOCIETY OF ARTS.

WEDNESDAY, 8TH DECEMBER, 1852.

JOHN SCOTT RUSSELL, F.R.S., IN THE CHAIR.

R. D. Hay, Esq., of Edinburgh, read a paper "On the Geometrical Principles involved in the Construction of the Human Frame." In this paper the author endeavoured to enforce the observations he has already made before the Society, and the truth involved in his theory of the natural principles of beauty developed in the human figure; and to reduce to geometrical principles certain simple and elementary conclusions. He attempted to establish the occurrence of a series of angles throughout the human frame, and which he would dispose in groups. He thus obtained what he calls "harmonious angles;" and to these he refers the correct proportions of the human frame, as well male as female, not only as regards dimensions, and the relative position of the centres of articulation, but also with relation to outline and contour.

WEDNESDAY, 15TH DECEMBER.

ROBERT STEPHENSON, ESQ., M.P., F.R.S., V.P., IN THE CHAIR.

A paper was read by Mr. Norton, describing an "Indicator for Registering Numbers, Distance, and Time." He proceeded to detail the various operations of the instrument, which is a considerable improvement upon the preceding ones, describing its effect in each instance of the well-known turnstile, &c. He also showed another form of the contrivance, by which he was enabled to set in motion a power that centralized in one point, and, at the same time, registered the ingress and egress from any number of stiles, situated at various distances from each other. This arrangement admitted of instant communication being made to each turnstile, and, consequently, of all the gates being locked at the same moment. He likewise explained its application to carriages and other things in motion, and an ingenious contrivance, by which a person who engaged a cab, for instance, might find the "fare" indicated according to the distance travelled. A lengthened discussion succeeded, in which the various qualities of the instrument, under many varieties of circumstances, were elicited.

MONTHLY NOTES.

MARINE ENGINEERING ON THE THAMES.—Amid the general prosperity of the mechanical and constructive arts, marine engineering seems just now to stand forward very prominently. One single firm—that of Messrs. Penn of Greenwich—has just now eleven pairs of marine engines in a forward state. Of these, the engines of the *St. Jean d'Acre*, 100 guns, and 650 horse power, are just finished, and the following are in hand at the Greenwich works:—400 horse power, for the *Royal Albert*, 131, building at Woolwich, and to be ready for putting on board in the latter end of July; 400 horse power, for the *Royal George*, converting into a screw steam-ship at Chatham; 400 horse power, for the *Euryalus*, 50, building at Chatham; 400 horse power, for the *Cæsar*, 90, building at Pembroke. All these are on Messrs. Penn's duplex-trunk principle—now in such high and deserved favour—and are for screw war-vessels. 350 horse power trunk engines, similar to the engines fitted in the *Impérieuse*, for the *Palka* Russian steam-frigate; 700 horse power, on the trunk principle, for the *Himalaya*, building for the Peninsular

and Oriental Company, supposed for the Australian service. This magnificent vessel will be much larger than the *Great Britain*, and her engines are similar to those in the *Agamemnon*, only of larger dimensions. 400 horse power oscillating engines for the *Vectis*, and one pair of 400 horse power oscillating engines for the *Valetta*, both belonging to the Peninsular and Oriental Company, and intended to carry the mails from Marseilles to Malta; 400 horse power oscillating engines for the Royal Mail steam-ship *Tamar*, building by Mr. Pitcher at Northfleet; 130 horse power oscillating engines for a war-steamer, building by Mr. Green for the Brazilian Government; 130 horse power oscillating engines for a war-steamer, building by Messrs. Wigram for the Brazilian Government; 50 horse power for the *Mermoid*, building by Messrs. Wigram for the Coast Guard service.

SILK DYED IN THE WORM.—In the course of speculations upon the known curious fact, that certain colouring matters, when given to animals along with their food, actually become incorporated in the system, and tinge the bones—as, for example, in the purple-dyeing of the living bones of the pig, by eating madder—M. Roulin, a French philosopher, has cleared his way for producing naturally-dyed silk. Indigo was first tried, the food of the silkworms being coloured by this dye, and eaten just before the spinning of the cocoons. M. Roulin mixed the indigo with the mulberry leaves, and at once obtained blue cocoons. Then casting about for a red matter capable of being eaten by the worms without injury to them, he came upon the *Bignonia chica*, and succeeded in obtaining red silk. Thus, this very elegant discovery, so long dormant and useless, now offers to become a valuable point in art-manufacture, and M. Roulin, who is still going on with his practical trials, anticipates the early production of silk, as secreted by the worm, of many other colours.

CAPTAIN NORTON'S PROJECTILES.—Captain Norton has forwarded us the following note for publication:—To-day, Ed. Le Fevre, Esq., fired one of my hollow expanding iron rifle-shot, having four projections on it, to fit easily into the four grooves of my rifle, fourteen to the pound bore, at five planks of deal, each an inch thick, at the distance of twenty yards, in Mr. Carey's shooting gallery. The charge within the shot was half a drachm of Hall's rifle powder, confined with a patch of thin calico greased on the side. A few grains of gunpowder were first put into the barrel, just enough to fill the nipple, and by the fire to pierce the centre of the calico patch. The shot penetrated four of the planks, and lodged in the fifth *point foremost*. I consider that the fact of similarly-formed shot of *cast malleable iron*, such as Mr. Onmanney's patent, being well adapted for rifle cannon, to be now fully established.—*Cork, 15th March, 1853.*

JOHN NORTON.

THE IRISH BEET-SUGAR WORKS.—The Beet Sugar Company, which we noticed some time ago, as being established at Mount Mellich, Queen's County, now seems ready to prosper. The whole works have been rebuilt, and the concern is now under the management of Mr. Wilhelm Hirsch, a gentleman who has gained considerable experience in the continental sugar factories. Within the last two months, he has sent eighty tons of sugar into the Dublin market; and, according to the opinion of the Cork grocers, it is superior, by 3s. per cwt., to the best imported sugar. Something is being said of the establishment of a factory in Cork. This looks well for the commercial success of the project.

RAILWAY WORKING EXPENSES AND ROLLING STOCK.—The cost of upholding and working the locomotive stock of the York, Newcastle, and Berwick line, for the last half year, is £56,789. The consumption of coke per mile, per train, is 40·39 lbs., the cost being 1·77d. Repairs and renewals come to 3·33d. per mile, and the total cost is at the rate of 7·24d. per mile, per train. There are 164 engines in working condition on the line, 23 under repair, 3 rebuilding, 14 requiring trifling repairs, and 5 working, but requiring to be entirely rebuilt, making a total of 209 engines. The number of miles run during the half year is 1,916,998, and, during this time, £20,421 has been expended on repairing and rebuilding carriages and waggons. The engineer's report on the new system of "fish-jointing" the rails—13 miles having been so treated—is most satisfactory.

WINDING MOTION FOR RING AND TRAVELLER SPRING FRAMES.*—The American invention, known in this country as the "Niagara throstle," has been lately modified and arranged, with a new winding motion, by Mr. Kimball, of Blackstone Mills, Massachusetts, who now winds the yarn on a bobbin, without either a top or a bottom head. Amongst the advantages which the inventor enumerates as being secured by his plan are, the superior lightness of the spindle, enabling it to be driven at a more than ordinary rate; less cost of bobbins, which are also less liable to fracture; removal of the upper head, doing away with the inconvenience of the bead getting rough, and breaking down the ends; without the bottom-head the bobbin will run as well as before, even if, by accident, it should not go down on the "collar"—whereas, with the head, it would run over, and make bad work; and it spools off easier and better, as in common ring-spinning the ends are apt to break off, and get drawn in under the heads. Mr. Kimball also states, that he has put the motion on a 120-spindle frame, which has now run two years—running it up to 115 turns on the front roller, No. 26 yarn, and 22 twist, spinning 8 skeins per spindle per day. In the same room are 120 frames of the ordinary kind, running at 80 turns only of the front roller, and their performance is much inferior to the new plan. The bobbin, when filled, has a taper at each end, like our "Dyer's frames;" that is, it commences to fill, with a traverse equal to the whole length of the yarn on the bobbin, the traverse being gradually shortened, until the bobbin is full.

THE MAGNET IN THE USEFUL ARTS.—One of the most recent uses to which magnets have been applied in the arts is in the manufacture of paper. Most persons must have observed on the leaves of books, more particularly those of an old date, certain offensive marks like spots of "ironmould." If we examine one of these

* For previous papers on the "Ring and Traveller Throstle," see pp. 177, 209, and 217, of our third volume.

blemishes, we shall, at the centre of it, find a minute particle of iron, the oxide of which, gradually formed by the natural moisture of the paper, has spread around to perhaps the size of sixpence or even larger. These iron particles, which come from the machines employed, and cannot be avoided, are now removed from the paper by magnets whilst it is fluid in the state of pulp. In many of the large manufactories of Birmingham and elsewhere, powerful magnets have been recently brought into use for the purpose of effecting the separation of the iron and brass filings produced in the work carried on; the filings of both metals are afterwards applied to various useful purposes, for which they would be utterly useless when mingled together as they come from the workshop: there is probably no other means by which they could be separated. In some manufactories on the continent, and I believe also in this country, where heavy iron and steel work is carried on, magnets are kept always at hand for the purpose of extracting the particles of the metal which frequently find their way into the workmen's eyes. The "needle-grinder's mask" is the next application of magnetism to be noticed; and there are lessons to be learned from the history of this invention. Any one who has visited the districts in which the needle manufacture is carried on, needs not be reminded of the deadly effect upon the workmen of the process they are engaged in. Inhaling all day-long from their earliest years an atmosphere impregnated with the steel-dust given off from millions of needles in the process of sharpening—(one man alone can point ten thousand in an hour)—before the age of twenty their health is utterly ruined, at thirty they are emaciated old men, and death comes proportionately early. A remedy was provided: the simple plan that each man should wear whilst at work a kind of respirator of steel wire, so acted upon by magnets, as, by the power of attraction, to intercept the fatal dust in its passage to the lungs. (Sir John Herschel remarks, that "by these masks the air is not merely strained but searched in its passage through them, and each obnoxious atom arrested and removed.") Glad, one imagines they would be, to take advantage of the discovery; but, one and all, they refused to adopt it. They are intelligent men, and cannot but be convinced of the efficacy of the invention, for, at the end of each day's work, the magnets are found to be covered with steel-dust, which otherwise must have passed into the lungs; but still they will not adopt it, because at present their wages are very high, proportionally to the mischief they are exposed to, or, we may say, to the short duration of their lives, and they apprehend reduced pay if their employment should be made a healthy one. The utility of the compass-needle in all surveying operations, every one must be acquainted with, as it forms an essential part of the theodolite. To the miner penetrating the recesses of the earth, and in all tunneling operations, it is almost as indispensable as to the seaman. A recent application of magnetism is, to the separation of iron ore from foreign matters, on the principle described in reference to the filings of metals.—*Magnetism; by G. E. Dering, Esq.*

GOODYEAR'S (U. S.) PATENT FOR VULCANIZING CAOUTCHOUC.—An important decision has just been given by the U. S. Commissioner of Patents, in the matter of an application on the part of Charles Goodyear, the assignee, for the prolongation of letters patent for the manufacture of india-rubber. After several extended hearings, the Commissioner decided that no extension of the term could be granted, because the inventor, Nathaniel Haywood, has assigned away all his interest in the invention before the issue of the patent, and, by the American Patent Laws, no extension can be issued to any party but the inventor.

THE ELECTRIC LIGHT.—The electric light has no characters in common with other artificial sources of illumination. Its brilliancy as obtained from carbon points, approaches, if not quite resembles, the light of day; its shadows, for depth, are equal to those of the most brilliant sunlight; and its diffuseness equals for effect that of the glorious orb itself. Colours which, by all ordinary lights, change as by a chameleon property their hues, are seen by it in all their purity of tint as in the broad light of noon. The eye, unable to bear its close approach, sees it emanating from its source in a thousand rays, which the moisture of the air and the imbecility of the optic nerve render varied by the brilliant tints of the rainbow. For the distance that its rays can travel seen, no other light but that of the sun can approach it. At sea, when the atmosphere is serene, it can be seen as far as the earth's convexity will allow the visual plane to extend. A point of one-tenth of an inch radiating the light, seems at one mile distant as a globe of fire a foot in diameter. Through coloured media, its effects are grand in the extreme; and, when assisted by optical aids, it really seems to extinguish all other lights in its vicinity. Seen through a large polygonal lens, it has been perceived in all the brilliancy of its ordinary unassisted state at a distance of thirty miles from the place of exhibition. It requires no air to support it, and burns as well under water as it does in vacuo.—*Dr. Watson on Electrical Illumination.*

THE AMERICAN EXPEDITION TO JAPAN.—A correspondent from Madeira writes as follows:—"Another American steam-vessel, forming part of the expedition to Japan, has anchored in Funchal Roads, for the purpose of taking coal on board. The squadron will consist, I am told, of thirteen vessels, five of which are steamers. The one here at present is the *Poussatan*, and she is the third that has touched at Madeira. Her dimensions are 278 feet by 46, and she is of 2,500 tons burthen. She has 310 souls on board, including the captain, five lieutenants, three surgeons, purser, master, and five midshipmen, a lieutenant of marines, a chief engineer, and five assistants. She carries nine guns, all of them 68-pounders, and a few brass field-pieces. She moves by paddles, and is propelled by two engines, each of 500 horse power, and these, with the boilers, &c., weigh altogether about 300 tons. The cylinders have a diameter of 70 inches, and the pistons a stroke of 10 feet. The boilers are of copper. She has a single chimney of nine feet diameter. The engines were designed by Charles H. Haswell, the chief engineer to the United States' navy, and were constructed last year at Mehaffey's Gosport Iron Works, Virginia. She has taken 700 tons of coal on board here, and she will coal again at the Cape of Good Hope. She is not strongly manned, men having been obtained

with much difficulty. The other vessels of the squadron are kept back from the same cause. It is said the American government is about to send out five vessels on a separate surveying expedition into the same quarter as that to which the present expedition is going."

PROVISIONAL PROTECTIONS FOR INVENTIONS

UNDER THE PATENT LAW AMENDMENT ACT.

When the city or town is not mentioned, London is to be understood.

Recorded January 8.

57. William Henderson, Bow-common—Improvements in manufacturing sulphuric acid and copper from copper ores, reguluses, and matts.

Recorded January 15.

106. Hippolyte C. Vion, Paris—Certain improvements in apparatus for refrigerating.

Recorded January 17.

116. Adolphe Iglesia, Fitzroy-square—Improvements applicable to machinery or apparatus for reeling or winding silk, cotton, or other fibrous substances, for the purpose of measuring or gauging the same.—(Communication.)

Recorded January 21.

154. William E. Newton, Chancery-lane—Improvements applicable to clocks and other timekeepers, for the purpose of indicating not only the time of the day, but the day of the week, the month, and the year, which invention he intends to denominate "Hawes' Calendar Clock or Timepiece."—(Communication.)

Recorded January 26.

196. Antoine G. Cazalat, Paris, and South-street, Finsbury—Invention of a new barometer and steam gauge.

Recorded January 28.

218. Thomas S. Pridaux, Garden-road, St. John's-wood—Improvements in the manufacture of iron.

Recorded January 29.

228. Thomas H. Wilson, Twickenham—Invention for securing carriage gates, doors, shutters, and sash casements.

Recorded January 31.

243. David S. Brown, Old Kent-road—Improvements in barometers, part of which invention is applicable to the registry of other fluctuations than those of barometers.

248. Richard Palmer, Bideford, Devon—An invention which may be used for cutting turnips, mangold-wurtzel, carrots, and other roots, or for bruising them only, or reducing them to a pulp, and for mixing them with meal, as may be required, and also for grinding or crushing apples for cider.

255. Edmund Leach, Rochdale—Improvements in the mode or method of preparing and spinning cotton, wool, flax, and other fibrous substances, and in the machinery or apparatus employed therein.

258. Frederick Lawrence, Pitfield-street, William Davidson, Halstead, and Alfred Lawrence, Pitfield-street—Improvements in engines to be worked by steam or other fluid.

Recorded February 1.

276. Alfred V. Newton, Chancery-lane—Improvements in block-printing machinery.—(Communication.)

Recorded February 2.

279. Auguste E. L. Bellford, Holborn—Invention of a new and useful composition of matter, termed "metallic oil," to be used for lubricating the axles of wheels and the rubbing or working parts of steam-engines, and every description of machinery and apparatus, for softening hemp and other fibrous substances, preparatory to spinning the same, and for other purposes.—(Communication.)

281. Auguste E. L. Bellford, Holborn—Improvements in life-boats and vessels of a similar nature.—(Communication.)

283. Auguste E. L. Bellford—Improvements in furnaces and apparatus combined therewith, for making wrought-iron directly from the ore, and for collecting and condensing the oxides or other substances evaporated in the process of deoxygenizing iron or other ores.—(Communication.)

285. John V. Kiddle, Elder-street—Improvements in cocks or taps.

287. Ismael I. Abadie, and Henri Lauret, Paris—An improved manufacture of parasols.

289. Thomas Paine, Woolwich—Improvements in heels for boots, shoes, and other coverings for the feet.

Recorded February 3.

290. Thomas Spiller and Anthony Crowhurst, Red Lion-square—Invention for the propelling steam vessels.

291. Manoa Bower, Birmingham—A new or improved apparatus to prevent the throwing up of mud by the wheels of vehicles.

292. John Heckethorn, Marquis-villas, Canonbury—Invention of an improved colouring matter for coating or covering the exterior or interior of buildings, some of the ingredients of which such colouring matter is composed being capable of conversion into size, paste, and ground-colour for priming, or giving the first coat or covering to work intended to be coloured with oil paint.

293. William S. Wright, Belgrave-square—An improved bath.

295. John Bower, Dublin—Improvements in and applicable to certain descriptions of engines for driving piles.

297. John H. Johnson, 47 Lincoln's-inn-fields, and of Glasgow—Improvements in gas burners, and in regulating the combustion of gas.—(Communication.)

299. Alfred Tylor, Newgate-street, and Henry G. Frasi, 84 Herbert-street—Improvements in water-closets.

301. John Crowther and Joseph Alsop, Huddersfield—Improvements in baking bread.

Recorded February 4.

302. William Brown, Birmingham—An improvement or improvements in the construction of metallic bedsteads.

303. David L. Price, Beaufort—Improvements in signalling by electricity on railway trains and railways, and in the appliances used therein.

304. Frederick J. Jones, Adde-street—Improvements in fastenings for bands, belts, straps, and other similar articles.—(Communication.)

305. Philip Webley, Birmingham—Improvements in repeating pistols and other fire-arms.

306. George Winwarter, 38 Red Lion-square—Certain improvements in the application of explosive compounds.

307. John Perkins, Manchester—Improvements in the treatment of certain bituminous mineral substances, and in obtaining products therefrom.

308. Robert Griffiths, Great Ormond-street—Improvements in the manufacture of bolts and rivets.

309. John Dudgeon, 42 Cornhill—Improvements in machinery used for raising propellers.
310. Jacob V. Asbury, Enfield—Improvements in railway carriages.
311. William Edgar, Giltspur-street—An improved hoot, particularly suitable for the use of emigrants and persons at sea.
312. George Letts, Northampton—Improvements in machines for cutting and mincing meat and other materials for sausages and other like purposes, and for filling the prepared skins with the meat and other materials when so cut.
313. William Walker, Manchester—Certain improvements in apparatus to be employed for the purposes of drying.
314. Alfred Woodward, Edglaston—Invention of a double-action vertical lever churn.
315. Alfred Woodward, Edglaston—Invention of a self-acting eam press.
- Recorded February 5.*
316. Richard Prosser, Birmingham—Improvements in the construction of printing rollers used in machines for printing calicoes and other substances.
317. Thomas Peacock, Ashton-under-Lyne—Certain improvements in weaving and in machinery for weaving hat plush and other cut-piled fabrics.
318. George Hewitson, Bradford—Improvements in machinery or apparatus for measuring or indicating the length of yarn as it is spun or wound on bobbins or rollers.
319. Antoine Wollowicz, Paris—Improvements in primers for fire-arms.
320. John Whitehouse the elder, and John Whitehouse the younger, Birmingham—Certain improvements in the manufacture of knobs for doors and other like uses, part of which improvements is applicable to the manufacture of certain articles of earthenware.
321. Charles F. Weyck-lagen, Barmen, Prussia—Certain improvements in the manufacture of carbonate of soda and potash.
322. William Crossby, Sheffield—Invention for the consumption or burning of smoke.
323. John Campbell, Bowfield, Renfrew—Improvements in the treatment or finishing of textile fabrics and materials.
324. Henry J. Nicoll, Regent-street—Improvements in garments for travelling.
325. Alexander Parkes, Barry Port, Carmarthen—Improvements in the separation of certain metals from their ores, or other compounds.
326. Edward Palmer, Woodford-green, Essex—Improvements in carriages used on railways.
327. Joseph Cowan, Liverpool—Improvements in propelling steam vessels.
- Recorded February 7.*
330. William Romaine, Sackville-street—Improvements in rendering wood more durable and unflammable.
331. William Scott, Robert Brough, James Rince, Brighton, and Thomas Mann, Stroud, Rochester—Improvements in steam-engines.
332. John L. Taberner, Lorn-road, North Brixton—Improvements in the mode of smelting iron and other ores, and in the manufacture of lime.
333. John L. Taberner, Lorn-road, North Brixton—Improvements in the application of granite and similar substances to ornamenting purposes, and to the construction of buildings.
334. Richard A. Brooman, 166 Fleet-street—Improvements in sail hanks for securing stay-sail jibs and other sails to their proper stays.—(Communication.)
- Recorded February 8.*
335. Auguste E. L. Bellford, 16 Castle-street, Holborn—Improvements in the treatment of bituminous and asphaltic matters, rendering them applicable to various useful purposes.—(Communication.)
336. Thomas Howarth, Rochdale—Invention of a certain improved cement for closing steam or other joints.
337. John Buchanan, Leamington—An improved propeller, as to affixing the blades in the boss, and affixing the bosses to the spindle or centre shaft, and in the mode of placing it, and in controlling, lowering, and detaching the same.
338. Thomas Allan, Adelphi-terrace—Improvements in protecting telegraph wires.
339. Thomas Allan, Adelphi-terrace—Improvements in galvanic batteries.
- Recorded February 9.*
340. Thomas Reynolds, Singleton-street, Hoxton, Henry Reynolds, Hoxton, and Stephen Reynolds, Charles-street, Westminster—Improvements in the means of retarding the progress of carriages.
341. Henry Pooley, Liverpool—Improvements in weighing machines.—(Partly a communication.)
342. William E. Newton, Chancery-lane—Improvements in machinery or apparatus for digging, excavating, or removing earth.—(Communication.)
343. William Binks, Timperley, and Samuel Bennett and Thomas Storey, Manchester—Certain improvements in pumps, or apparatus for raising and forcing fluids.
344. John Little, Glasgow—Improvements in lubricating mechanism.
345. William Birkett, Bradford—Improvements in treating soap-suds or wash-waters in which soap has been used.
346. John Seaward, Poplar—Improvements in marine engines.
347. Isalah J. Machin, Leigh-street—An improvement in nut-crackers.
348. Charles Iles, Birmingham—Improvements in pointing wire.
349. John Webster, Ipswich—Improvements in treating animal matters, and in manufacturing manure.
- Recorded February 10.*
350. James S. Wilson, Tavistock-square—Improvements in the construction of furnaces or flues, whereby economy in the use of fuel, the consumption of smoke or gases, and the utilizing thereof are insured.
351. William J. Curtis, 25 Behn-lane—An improvement in candlesticks.
352. Charles Cuyllis, Antwerp—Improvements in apparatus for regulating or governing the speed of steam or other engines.—(Communication.)
353. William E. Newton, Chancery-lane—Improvements in instruments or apparatus for facilitating the examination of various internal parts of the human frame.—(Communication.)
354. John Hunter, Glasgow—Improvements in the manufacture of textile fabrics.
355. William Fulton, Paisley—Improvements in the treatment, cleansing, or finishing of textile fabrics.
356. James Anderson, Auchnagie—Improvements in steam-engines.
357. William Ball, Ilkerton—Improvements in machinery for producing looped fabrics.
358. Henry M'Farlane, Lawrence-lane—Improvements in machinery for excavating.—(Communication.)
359. Robert Ash, 211 High-street, Southwark—Improvements in stopping bottles and other vessels.
360. George Hutchinson, Glasgow—Improvements in treating oils and other fatty matters.
361. Charles Breeze, Birmingham—Improvements in ornamenting papier-maché, japan, red iron, china, and other hard or bright surfaces with gold.
362. Robert Roger, Stockton-on-Tees—Improvements in obtaining motive power.
363. William Potts, Birmingham—Improvements in sepulchral and other commemorative monuments.
- Recorded February 11.*
364. Robert Thomas, Manchester—Improvements in machinery or apparatus applicable to planing, slotting, shaping, grooving, or other similar purposes.
365. Sir James Murray, Dublin—Improvements in deodorizing cod liver oil, in rendering it more agreeable and easier to use either by itself or mixed, and so as to be capable of being administered in larger quantities, and with greater success.
366. Antoine Sanguinède, Paris, and 16 Castle-street, Holborn—An improved clasp or buckle.
367. William Choppin, London—Improvements in locks.
368. Robert D. Kea, St. George's-road, Southwark—Improvements in bits.
- Recorded February 12.*
369. Thomas R. Mellish, Sloane-street, Chelsea—Improvements in the construction and mode of closing scent and other bottles.
370. John F. Stanford, Arundel-street—An improvement in the method of draining dwelling-houses and other buildings, and open and enclosed spaces in cities and towns where sewers and drains are now or may be hereafter constructed.
371. George Winwarter, Red Lion-square—Improvements in fire-arms.
372. Thomas J. Perry, Birmingham—Invention of a new or improved method of constructing cornice poles and picture and curtain rods, and other rods from which articles are suspended.
373. George Farry, Monmouth—Improvements in blast furnaces.
374. George H. Bursill, Offord-road, Barbury-park, Islington—Improvements in operating upon auriferous quartz, clays, and other minerals, preparatory to and in order to accomplish the separation of the gold and other metals, also in machinery or apparatus for effecting such improvements.
375. George L. Lysnar, 85 Parke-street, Grosvenor-square—Improvements in swivel hooks and such like fasteners.
376. William Pidding, Strand—Improvements in crushing, drilling, or otherwise treating ores, stone, quartz, or other substances in mining operations, and in the machinery or apparatus connected therewith.
377. William Pidding, Strand—Improvements in the treatment of oleaginous, fatty, or gelatinous substances, for purifying, decolorizing, compounding, or clarifying the same.
378. Charles Hadley, Birmingham—Improvements in the means of communication between the passengers, guard, and driver of a railway train, parts of which improvements are applicable to communicating on vessels.
- Recorded February 14.*
379. William E. Newton, Chancery-lane—Improvements in apparatus to be employed for veneering surfaces.—(Communication.)
380. Charles J. Burnett, Edinburgh—Certain improvements in apparatus or mechanism for driving machinery through the agency of water.
381. Peter Armand le Comte de Fontaine Moreau, 4 South-street, Finsbury, and 39 Rue de l'Échiquier, Paris—Certain improvements in treating fibrous substances.—(Communication.)
382. Peter Armand le Comte de Fontaine Moreau, 4 South-street, Finsbury, and 39 Rue de l'Échiquier, Paris—Improvements in the mode of giving flexibility to beds, sofas, seats, and other similar articles.—(Communication.)
383. Peter Armand le Comte de Fontaine Moreau, 4 South-street, Finsbury, and 39 Rue de l'Échiquier, Paris—Certain improvements in the manufacture of tiles for roofing.—(Communication.)
384. Jean A. Gervais, 4 South-street, Finsbury—Certain improvements in treating fermentable liquids, and in the machinery or apparatus employed therein.
385. Francis C. Moulton, 4 South-street, Finsbury—An improved mode of raising water.
386. Claude J. Lambert, 4 South-street, Finsbury—Certain improvements in the preparation of bread and biscuits.
- Recorded February 15.*
387. William Clark, 31 Chancery-lane—Improvements in the manufacture of colours and paints.—(Communication.)
388. John Bethell, 8 Parliament-street—Improvements in obtaining copper and zinc from their ores.—(Communication.)
389. Benjamin Greening, Manchester—Improvements in machinery for making fences, and other similar articles of wire.
390. Thomas W. Kennard, Duke-street, Adelphi—Improvements in apparatus for improving the draught of chimneys.
391. Frederick Chincock, 28 Regent-street, St. James's—Improved means of securing axles in their boxes.—(Communication.)
392. George Stiff, Brixton-hill—Certain improvements in manufacturing paper.
393. Adolphe Nicole, 80 Dean-street, Soho-square—Improvements in rotary engines.
394. Alphonse Rene le Mire de Normandy, Judd-street—Improvements in the manufacture of articles made of gutta percha.—(Partly a communication.)
395. William B. Whitton and George S. Whitton, 18 Princes-street, Lambeth—Improvements in the manufacture of sewer and other pipes.
396. Joseph and Alfred Ridsdale, Minories—Improvements in ships' side-lights, scuttles, or ports.
397. Henry Dircks, 32 Moorgate-street—An improved sewing-machine.—(Communication.)
398. Henry Francis, West Strand, St. Martin's-in-the-fields—Improvements in instruments for cutting wool, hair, and vegetable matters.
- Recorded February 16.*
400. Henry S. Ludlow, 107 Redcliff-street—An improved process for simultaneously removing dust, stones, or other foreign matter, and for separating the superior and inferior grains in wheat, barley, and malt.
401. Job Cutler, Birmingham—Improvements in the manufacture of spoons and forks, and other similar articles for domestic use.
402. Benjamin Cook, Birmingham—Improvements in apparatus for lighting fires.
403. George G. Mackay, Grangemouth—Improvements in the construction of drain pipes.
404. Joseph Skerthly, Kingsfield, Middlesex—Improvements in copying presses.
405. John Day, Islington—Improvements in apparatus for holding and protecting insulated telegraphic wires.
406. Edouard Sy, 17 Clifford-street, Bond-street—Improvements in book-binding.
407. John G. Perry, 12 Westbourn-street, Hyde-park-gardens—Improvements in book-binding, to facilitate the finding of places in books.
408. Charles Sheppard, near Bridgen, Glamorgan—An improved stove and apparatus for heating air for blast purposes.
409. Wright Jones, Pendleton—Improvements in machinery or apparatus for stretching woven fabrics.
410. Alfred V. Newton, Chancery-lane—Improvements in the manufacture of printing surfaces.—(Communication.)
- Recorded February 17.*
411. John C. Brown, Dover Castle—Improvements in the propelling of vessels.
412. William B. Adams, Adam-street, Adelphi—Improvements in railways.
413. James Murphy, Newport—Improvements in the permanent way of railways.
414. William Pidding, Strand—Improvements in the treatment and preparation of saccharine substances, and in the machinery or apparatus connected therewith.
415. Matthias Walker, Horsham—Improvements in vessels or apparatus for containing and preserving ale, beer, and other liquors.
416. Charles Gordon, Washington, U. S.—An improved goniometric protractor, or instrument for setting out and measuring angles and other geometric figures.

417. David Cochrane, Manchester—Certain improvements applicable to closing doors.
 418. Thomas C. Ogden, Manchester, and William Gibson, same place—Certain improvements in machinery or apparatus for spinning cotton and other fibrous materials.
 419. George L. L. Kufahl, Weymouth-terrace, City-road—Improvements in the application of atmospheric currents to the obtaining of motive power.
 420. William Hawes, 17 Montague-place, Russell-square—Improvements in the manufacture and refining of sugar.
 421. Charles Watt, Selwood-place, Brompton, and Hugh Burgess, 27 Grove terrace, Kentish-town—Improvements in coating iron with copper and brass.
 422. Isaac Frost, 49 Tavistock-terrace—Improvements in reaping or cutting crops.

Recorded February 18.

423. James Horsfall, Birmingham—An improvement or improvements in the manufacture of piano-forte wire, applicable also to articles of iron and steel generally.
 424. Peter Madden, Kingston, near Dublin—Improvements in propelling, steering, and regulating vessels.
 425. Charles B. Clough, Tyddyn, Mold—Certain improved apparatus for detaching boats or other floating vessels from their moorings or fastenings.
 426. William Darling, Glasgow—Improvements in the manufacture of malleable iron and other metals.
 427. Charles Kinder, Chesterfield—Improvements in mantel or chimney pieces.
 428. Henry Noad, Stratford—Improvements in treating corn or grain, and obtaining products therefrom.

Recorded February 19.

430. James C. White, Liverpool-street—Improvements in fastenings for harness, and which are also applicable to other like purposes.
 431. Frank C. Hills, Deptford, and George Hills, Lee—Certain improvements in refining sugar, and in preparing materials applicable to that purpose.
 432. William R. Dell, Warrington—Improvements in the manufacture of cylinders, coated with fine wire webbing, for dressing fine flour by the process of gravitation or sifting, without the aid of any internal brushes or fans.
 433. Charles Cowper, Chancery-lane—Improvements in the manufacture of oxide of zinc or zinc white, and in apparatus for that purpose.—(Communication.)
 434. Charles Nightingale, Wardoan-street, Soho—Certain improvements in drying and heating certain substances or articles.
 435. James Anderson, Auchnagie, Perthshire—Improvements in obtaining motive power.
 436. Pierre A. Tourniere, Upper Kennington-lane—Improvements in propelling.

Recorded February 21.

437. Wright Jones, Pendleton—Improvements applicable to steam pipes used for warming, drying, or ventilating.
 438. Samuel R. Samuels and Robert Sands, Nottingham—Improvements in looms for weaving.
 439. John O'Leary, Liverpool—Certain improved apparatus for indicating the number of passengers entering in or upon omnibuses, and also their exit therefrom.
 440. Joseph Ramage, Manchester, and Thomas Coffey, same place—Certain improvements in the manufacture of chandeliers, gas brackets, and lamp frames.
 441. James Mash, Kentish-town, and Joseph S. Bailey, Keighley—Improvements in weaving machinery employed in the manufacture of textile fabrics, and in the manufacture of such fabrics.
 442. William Pidding, Strand—Improvements in coverings for the feet of bipeds or quadrupeds.
 443. Richard Farrant, Pimlico—An improved chimney-pot.
 444. Ezra Miles, Sonbury, Bucks—Improvements in railway brakes.
 445. Thomas Bell, Bristol, and Richard Chrimes, Rotherham—Certain improvements in valves, applicable to the receiving and discharging of water or other fluids.
 446. Benjamin Barton, Old Kent-road—An improved bath, which can also be used as a life-boat.
 447. John C. Pearce, Bowling Iron Works, near Bradford—Improvements in steam boilers.
 448. John D. M. Stirling, Larches, near Birmingham—Improvements in the manufacture of wire.
 449. William Wilkinson, Nottingham—Improvements in the manufacture of ropes, bands, straps, and cords.

Recorded February 22.

450. James Hudson, Halifax, and Thomas B. Hudson, Malton—Improvements in the manufacture of bricks, tiles, and drain pipes or tubes.
 451. Pierre F. Gongy, Castle-street, and David Combe, King-street, Middlesex—Improvements in apparatus for skidding or stopping wheels of carriages and other vehicles.
 452. George Winiwarter, Red Lion-square—Improvements in the manufacture of fire-arms.
 453. John R. Cochrane, Glasgow—Improvements in the manufacture or production of ornamental or figured fabrics.

Recorded February 23.

454. Samuel Beckett, Manchester—An improvement or improvements in mule spindles, and spindles of a similar description, for spinning or twisting various fibrous substances, and in the mode of manufacturing and producing the same.
 455. John Smith, Uxbridge—Improvements in machinery for raising and forcing water and other fluids.
 456. Edwin S. Brookes and Joseph Black, Loughborough, and George Stevenson and William Jones, same place—Improvements in machinery for the manufacture of looped fabrics.
 457. Eduard Albrecht, Upper Fountain-place, City-road—Improvements in apparatus for transmitting and reflecting light.
 458. Reuben Plant, Brierley-hill, Staffordshire—Improvements in safety lamps.
 459. Robert Milligan, Harden-Mills, Bingley—Improvements in apparatus for washing slivers of wool.
 460. Samuel C. Lister, Bradford—Improvements in treating soap-suds.
 461. Asa Willard, St. John's, New Brunswick—Improvements in machines for manufacturing butter, to be called "A. Willard's Butter Machine."
 462. Adam C. Engert, Mora-place, City-road—Improvements in joints for the sticks of parasols, and other like purposes.—(Communication.)

Recorded February 24.

463. John Green, New-road, Marylebone—Invention of the more economic, speedy, convenient, and in every respect superior system of cooking to any now in use, and which he designates "Green's Economical Self-Basting Cooking Apparatus."
 464. William Spence, Chancery-lane—Improvements in machines for thrashing and winnowing corn and other agricultural produce.—(Communication.)
 465. Henry Walmesley, Failsworth, near Manchester, and Thomas Critchley, same place—Improvements in machinery or apparatus for retarding or stopping railway trains, which machinery or apparatus is also applicable as a signal or communication from one part of a train to the other.
 466. Peter McLellan, Bridge of Earn, Perthshire—Improvements in thrashing machinery.
 467. William Johnson, 47 Lincoln's-inn-fields, and Glasgow—Improvements in the treatment or manufacture of casouthouse.—(Communication.)
 469. Thomas De La Rue, Bonhill-row—Improvements in producing ornamental surfaces on paper and other substances.

470. Emile A. Herrmann, New Broad-street—Certain improvements in machinery for manufacturing woollen cloth.—(Communication.)
 471. James Lawrence, Colnbrook—Improvements in the drying or preparation of malt, meal, seeds, corn, and other grain.
 472. Thomas B. Jordan, New-cross, Kent—Improvements in machinery for planing slate.

Recorded February 25.

473. Francis Preston, Manchester—Improvements in the manufacture of certain parts of machinery to be used in preparing and spinning cotton or other fibrous materials.
 474. John Hynam, Finsbury—Improvements in the mode of manufacturing wax or composition tapers, and in the machinery or apparatus for that purpose.
 475. Benjamin Price, Fieldgate-street, Whitechapel—Certain improvements in the construction of furnaces or flues of steam boilers, coppers, and other like vessels for heating or evaporating liquids.
 476. John Grist, Hoxton—Improvements in machinery for the manufacture of casks, barrels, and other similar vessels.
 477. William Symington, 41 Gracechurch-street—Improvements in preserving milk and other fluids.
 478. John P. De la Fons, 13 Carltonhill—Improvements in applying skids or drags to omnibuses.
 479. Thomas Richardson, Newcastle-upon-Tyne—Improvements in the manufacture of certain compounds of phosphoric acid.
 480. Henry M. Nicholls, 39 Gower-place, Euston-square—Improvements in emission or reaction engines.
 481. Antonio F. Cossus, University-street, Middlesex—Improvements in filters.
 483. Frederick Goodell, Piccadilly—An improved apparatus for the distillation of rosin oil, and for an improved method of bleaching and deodorizing the same during the process of manufacture.—(Partly a communication.)

Recorded February 26.

484. Charles N. Wilcox, Islington—Improvements in the manufacture and application of certain extracts obtained from the elder-tree.
 485. Jean J. Fréchin, Bordeaux, France, and Finsbury—Improvements in the construction of locomotive engines.
 486. William M. Shaw, Brighton—An improvement in the construction of locomotive boilers.
 487. Joseph Brandeis, Great Tower-street—Improvements in the manufacture and refining of sugar.
 488. Mark H. Blanchard, Blackfriars-road—Improvements in the manufacture of pipes of earthenware, clay, or other similar materials.
 489. William E. Newton, 66 Chancery-lane—Improvements in machinery or apparatus applicable to wheels or axles for counting and indicating the number of rotations made thereby.—(Communication.)
 490. Ebenezer Thornton, Huddersfield—Certain improvements in the construction and arrangements of kitchen boilers and flues for ranges.
 491. Hon. James Sinclair, commonly called Lord Berriédale, 17 Hill-street—Improvements in weaving.
 492. Robert Griffiths, Great Ormond-street—Improvements in propelling vessels.
 493. Charles Tetley, Bradford—Improvements in obtaining power by steam and air.
 494. Charles Tetley, Bradford—Improvements in the manufacture of hobbins.
 495. Samuel Varley, Wainfleet, Lincoln—Improvements in making communications between the guards and engine-drivers on railway carriages.
 496. Earl of Dundonald, Belgrave-road—Improvements in producing compositions or combinations of bituminous, resinous, and gummy matters, and thereby obtaining products useful in the arts and manufactures.

Recorded February 28.

497. Theodore Baron von Gilgenheimb, Weidenau, Silesia—Invention of a new machine, with its adjuncts or other apparatus, to be used for agricultural purposes.
 498. James Murphy, Newport—Improvements in trucks, waggons, or vehicles for railway purposes.
 499. Thomas E. Merritt, Maidstone—Improvements in railway carriages, and in connecting and disconnecting them.
 500. Martyn J. Roberts, Gerard's-cross, Bucks—Improvements in the manufacture of mordants, or dyeing materials, which are in part applicable to the manufacture of a polishing powder.
 501. Edward H. Bentall, Heybridge—Improvements in harrows.
 502. George Duncan, Chelsea—Improvements in steam boilers.
 503. Peter Armand Le Comte de Fontaine Moreau, 4 South-street, Finsbury, and 39 Rue de l'Echiquier, Paris—Improvements in drying cigars.
 504. Joseph Major, 10 Little Stanhope-street—Improvements in preparing lotions, which he intends to call the "Synovitic Lotions."
 505. Samuel C. Lister, Manningham, near Bradford—Invention of heating and making cards.

Recorded March 1.

506. Robert Stephenson, jun., Newcastle-on-Tyne—Improvements in locomotive engines.
 507. Thornton Littlewood and Charles Littlewood, Rochdale—Improvements in machinery or apparatus used in the preparation of wool, silk, flax, and mohair to be spun.
 508. John Bethell, Westminster—Improvements in preserving wood from decay.
 509. Joseph C. Daniell, Limpley Stoke, Bradford—Invention of propelling vessels of all descriptions that float on water that are capable of carrying steam, or any other engines used for the purpose of giving power to propel vessels, also for propelling carriages on roads to which engines for the purpose of giving power to work them can be applied.
 511. Edward Charlesworth, York—Improvements in bill or letter holders.
 512. William Rowett, Liverpool—Improvements in making paddle-wheels for vessels propelled by motive power, which is called "The Cylinder Paddle-Wheel."
 513. Charles Flude, Old Kent-road, and James Waterman, Southwark—Improvements in the application of heat for producing evaporation, generating steam, and for general heating purposes, and also in the economical production of combustible gases for the purpose of illumination.
 514. John M'Adams, Massachusetts, U.S.—Improvements in machinery or apparatus for printing on leaves of books their designations, numbers, or devices, or those of their pages, which machinery or apparatus may also be used to advantage for printing designating numbers or devices on various other articles.
 515. Robert L. Bolton, Liverpool—Invention of a new mode of obtaining and using power by explosion of gases.

Recorded March 2.

516. Laurence Hill, junior, Port-Glasgow—Improvements in the production of motive power.—(Communication.)
 517. Charles H. Hall, Liverpool—An improved apparatus for cooking by gas or vapour.
 518. Howard A. Holden, Alfred Knight, Edward Bull, and John Banfield, Birmingham—Certain improvements in communicating and giving signals between the engine drivers and guards on railway trains, being in connection with a mode already patented for effecting the same object.
 519. James Abbott, Acerrington—Certain improvements in and applicable to machines

for winding yarn or thread, called "winding machines used in the manufacture of cotton and other fibrous substances."

520. Alexis Soyer, Fenchurch-street—Improvements in preparing and preserving soups, which he denominates "Soyer's Osmazone Food."
 521. John Smith, City-road, William H. Smith, same place, and Alexander Williams, Great Tower-street—Certain improvements in metallic plates, and in producing devices or ornamental patterns thereon, and in the apparatus and machinery to be used for such purposes.
 522. Edward D. Moore, Ranton Abbey, near Ecclesball—An improved mode of treating the extract of malt and hops.
 523. Lewis Jennings, Fludyer-street—An improved apparatus for regulating the speed of machinery.
 524. Alfred A. de Reginald Heley, Westminster—An improved door or finger plate.
 525. Robert Waddell, Liverpool—Improvements in steam-engines.
 526. Marcel Veillard, Le Mans, France—Improvements in drying yarns.
 527. Willoughby T. Monzani, Camden-town—Improvements in reaping machinery.

Recorded March 3.

528. William Clark, Islington—Improvements in propelling and steering vessels, and in the apparatus used therein.
 529. James Murdoch, 7 Staple inn, Middlesex—An improved process for the manufacture of iodine.—(Communication.)
 530. Simon O'Regan, Belfast—Improvements in apparatus for consuming smoke.
 531. Charles Humpage, King's Norton, Worcester—Invention for the application of certain materials to the manufacture of coffin furniture.
 532. Auguste E. L. Bellford, 16 Castle-street, Highborn—Improvements in locomotives, part of which improvements are applicable to other steam-engines.—(Communication.)
 533. Martin Billing, 142 High Highborn—Certain improvements in metallic bedsteads.
 534. Samuel Colt, Spring-gardens, Middlesex—Improvements in rotating breech fire-arms.—(Partly a communication.)
 535. Samuel Colt, Spring-gardens, Middlesex—An improved construction of blower.—(Communication.)
 536. Samuel Colt, Spring-gardens—Improved machinery for forging metals.—(Partly a communication.)
 537. Samuel Colt, Spring-gardens, Middlesex—Improvements in rotating breech fire-arms.—(Partly a communication.)
 538. Bernard Chaussonot the elder, Paris—Improvements in apparatus for aerating liquids.
 539. William E. Newton, 66 Chancery-lane—Improvements in primers for fire-arms.—(Communication.)
 540. John Wright, Camberwell—Improvements in machinery for manufacturing bags or envelopes of paper, calico, or textile fabrics.
 541. Thomas Crick, Leicester—Improvements in the manufacture of boots, shoes, clogs, and slippers.
 542. James Waterman, Park-street—Improvements in treating brewery and distillery grains, for the production of food for cattle, and for extracting the bitter principle and other products from the refuse hops of breweries.

Recorded March 4.

543. John Hinks and George Wells, Birmingham—Invention of a new or improved metallic pen.
 544. Robert C. Ross, Edinburgh—An improved machine or instrument for cutting files and forging metal.
 545. George Elliot, St. Helen's, Lancashire—Certain improvements in manures.
 546. Joseph S. Hall, Regent-street—Improvements in cutting out parts of boots and shoes.
 547. William Sandilands, Elm Tree Lodge, South Lambeth—An improved hopper for a piano-forte.
 548. Samuel H. Huntly, Marylebone—Improvements in controlling and regulating the flow or pressure of gas.
 549. Henry McEvoy, Birmingham—Improvement in covered buttons.
 550. George W. Bott, Manchester—Improvement in apparatus called "pressers," employed in the preparation of cotton and other fibrous materials for spinning.
 551. James Boydell, Smethwick, near Birmingham—Improvements in the construction of bedsteads.
 552. John D. M. Stirling, Larches, near Birmingham—Improvements in manufacturing coated metal.

Recorded March 5.

553. Mary A. Smith, Marylebone—Improvements in the manufacture of toys, models, and other like articles of ornament or utility.
 554. John Gedge, Strand—Improvements in the construction of fire-arms, and in the means of loading the same.—(Communication.)
 555. Baldwin F. Weatherdon, Chancery-lane, and Charles Deatry, Guernsey—Improvements in the construction of certain floating vessels, and in the mode of propelling them.
 556. Thomas W. Cross, Leeds—Invention of a portable fire-engine.
 557. William Todd, Rochdale—Improvements in steam-engines.
 558. Joseph Maudslay, Lambeth—Improvements in screw propellers for ships and other vessels.
 559. Richard A. Brooman, Fleet-street—Improvements in machinery for making pipes and tubes.—(Communication.)
 560. John Hirst, junior, Dobeross, York, and William Mitchell, Crosland Moor, near Huddersfield—Improvements in stretching fabrics.

Recorded March 7.

561. Richard Barter, M.D., Blarney, Cork—Improvements in cutting roots and other vegetable substances.
 562. William Barrington, Mallow, Cork—An improvement in life-boats.
 563. James G. Lynde, junr., Great George-street—Invention of a pressure governor, or self acting apparatus for regulating the flow of water.
 564. Henry Mapple, Child's Hill, Hendon—Certain improvements in electric telegraphs and apparatus connected therewith.
 565. André Calles, Finshury—Certain improvements in manufacturing typographic characters.
 566. Jacques François Dupont de Bussac, London, 19 Royal Avenue-terrace, Chelsea—Certain improvements in paving and covering places.—(Communication.)
 567. Godfrey Simon and Thomas Humphreys, Pennsylvania, U. S.—Improvements in carriages.
 568. William Matthews, 5 St. James-street, Nottingham—Improvements in piano-fortes.
 569. Joseph J. W. Watson, Old Kent-road—Improvements in illuminating apparatus, and in the production of light.
 570. Thomas W. Dodds, Rotherham—Improvements in the treatment and manufacture of iron and steel.
 571. Charles Parker, Dundee—Improvements in weaving.
 572. John Little, Glasgow—Improvements in cooking apparatus.
 573. Thomas W. Dodds, Rotherham—Improvements in the manufacture of wheels and axles.
 574. Thomas T. Chatwin, Birmingham, and Robert M. Leish, same place—Improvements in rollers, rods, or poles, for window blinds, curtains, maps, and such like purposes.

Recorded March 8.

575. Charles Finlayson, Manchester—Improvements in apparatus for converting reciprocating into rotatory motion for steam-engines, and for other purposes.
 576. Thomas J. Perry, Lozells, Warwick—A new or improved method of constructing cornice poles, and picture and curtain rods, and other rods from which articles are suspended.
 577. Thomas Dryland, 81 Bishopsgate-street Within—An improved portable iron stove.
 578. Jacques F. Pinel, Pall-mall—Improvements in deodorizing sewage water and cess-pools, and in manufacturing manures.
 579. Nicolas Schmitz, Gofontaine, Prussia—Improvements in cleansing and separating ores and coal.
 580. Charles Baker, Southampton—Improvements in moulds for the manufacture of bricks.
 581. John Wright, Camberwell—Improvements in the construction of bedsteads and other frames.
 582. Alexander Samuelson, Hull—Improvements in the manufacture of bricks and tiles.
 583. Frederick W. Emerson, Penzance—Improvements in obtaining tin from ores.
 584. James Veevers, Littleborough, and Henry Ashworth, same place—Certain improvements in machinery or apparatus to be employed in the preparing of cotton and other fibrous materials for spinning.
 585. Thomas Glover, Woodstock—A certain improvement in the construction of buttons, and in the mode of applying the same to gloves and other articles of dress.
 586. John Colquhoun, Paisley—Improvements in bleaching or sulphuring silk, woollen, cotton, and other woven fabrics and yarns.
 587. John J. A. M'Arthy, 36 Howland-street, St. Pancras—Improvements in gunnery and projectiles, with pouch for the latter, which are adapted for muskets, rifles, pistols, and heavy cannon for field-pieces, or forts, batteries, ships of war, and other vessels.

Recorded March 9.

588. James Kimberley, Birmingham—A new or improved gas stove.
 589. Samuel Blackwell, Oxford-street—An improved strap or band for connecting together certain parts of harness and saddlery, applicable also to other purposes where straps or bands are used.
 590. William Pidding, Strand—Improvements in the treatment or manufacture of caoutchouc or gutta percha in fabrics obtainable therefrom, and in the machinery or apparatus employed therein.
 591. Theophilus J. Nash, 202 High Highborn—Improvements in churns.
 592. Edward Maitland Stapley, Lawrence-lane—Improvements in machinery for breaking and dressing flax and other fibrous materials.—(Communication.)
 593. William A. Holskamp, 58 Ossulston-street, Somerstowu.—An improved castor for legs of furniture, and other purposes.

DESIGNS FOR ARTICLES OF UTILITY.

Registered from 9th February, to 10th March, 1853.

- | | | | |
|-----------|------|---|---------------------------------------|
| Feb. 9th, | 3419 | Henry and John Gardner, Strand,— | "Fish-tail burners." |
| 10th, | 3420 | Benjamin Sawdon, Huddersfield,— | "Portable gas apparatus." |
| — | 3421 | Dent, Allcroft, & Co., Wood-street,— | "The club-house cravat." |
| 18th, | 3423 | J. Barlow, King William-street,— | "Spring hat suspender." |
| 19th, | 3424 | J. Baker, Birmingham,— | "Pencil-case." |
| — | 3425 | G. Marr, Russell-square,— | "Gas stove." |
| 25th, | 3426 | M. Roth, M.D., Old Cavendish-street,— | "Russian bath." |
| — | 3427 | Hargraves, Harrison, & Co., Wood-street,— | "Parasol joint." |
| March 3d, | 3428 | E. Thornton, Huddersfield,— | "Gas retort." |
| — | 3429 | C. B. Curtis, Lombard-street,— | "Screw nozzle for powder-cannisters." |
| 7th, | 3430 | J. Taylor & Sons, Warwick-lane,— | "Syringe." |

DESIGNS FOR ARTICLES OF UTILITY.

Provisionally Registered from 9th February, to 10th March, 1853.

- | | | | |
|-----------|-----|---|--|
| Feb. 9th, | 402 | Hyman Lewiston, Mary-street, Kingsland-road,— | "Bib for infants, or chest-protector." |
| 28th, | 403 | J. Morris, Clapham-road,— | "Corkscrew." |
| Mar. 4th, | 494 | N. Ager, Picnic,— | "Valve." |
| 5th, | 495 | A. J. Schott, St. James's,— | "Drum castanet." |
| 10th, | 496 | W. G. Haig, New North-road,— | "Watch protector." |

TO READERS AND CORRESPONDENTS.

THE UNITED STATES.—We have frequently alluded to the way in which books and heavy parcels of drawings, &c., have been sent to us from the United States without prepayment; and during the past month a copy of the Report of the U.S. Commissioners of Patents came to our address with a charge of £2. 10s. for postage upon it. Although we place great value upon these reports, and are sensible of the politeness of the Commissioners in sending them to us, yet, as we cannot afford to accept the favour at so high a cost, and as we can purchase the book in London for 10s., we were compelled to refuse it. In future, we shall be obliged to our friends in the United States favouring us with heavy communications, or with books for review, if they will transmit them to us through our publishers in New York, Messrs Stringer and Townshend.

J. F.—Much more than the subject seems really to deserve, has already been said. We have no credible particulars by us, that carry us in the least degree beyond what has been long since clearly elucidated. We shall not lose sight of the matter, but in the meantime we can only refer our correspondent to the "Imperial Cyclopædia of Machinery," for a plate and general description of the machinery.

H. M., Stockton.—Electro-magnetism, as a motive power, has never been treated of in any separate work, but our correspondent may find much interesting matter of this kind in the "Franklin Journal," "Philosophical Magazine," "Silliman's Journal," and others.

RECEIVED.—"Magnetism. A Lecture. By G. E. Dering, Esq."

H. S., London.—We regret that we have been obliged to postpone this paper for a month.

L. G.—We have been compelled to keep back these notes also.

INQUIRE.—The cause of his complaint has entirely arisen from causes beyond our control; but we shall shortly give the set complete, and on a more elaborate scale than at first intended.

J. D., Friargate.—The point is a very deceptive one, and has often led to lengthy discussions, although it is really a very simple affair. Theoretically—length makes no difference—practically, however, it does; because the deviation of the hand less affects the objectionable angle between the axis of the instrument and its work, as the length increases; and the workman's perception of this difference is heightened by the larger handle which usually accompanies superior length. See an elaborate illustrated paper on this subject, by Professor Sang, in a back volume of the *Transactions of the Royal Scottish Society of Arts*, to be found, no doubt, in the Preston Institution Library.

A Correspondent from Merthyr wishes to know, "what the viscous constituent of castor-oil is, and if by any means it can be removed, so that the oil may be rendered thin and fit for lubrication." As to the other inquiry, see reply to "Chemists, Mostyn," in this *Journal*, Part 54, last volume.

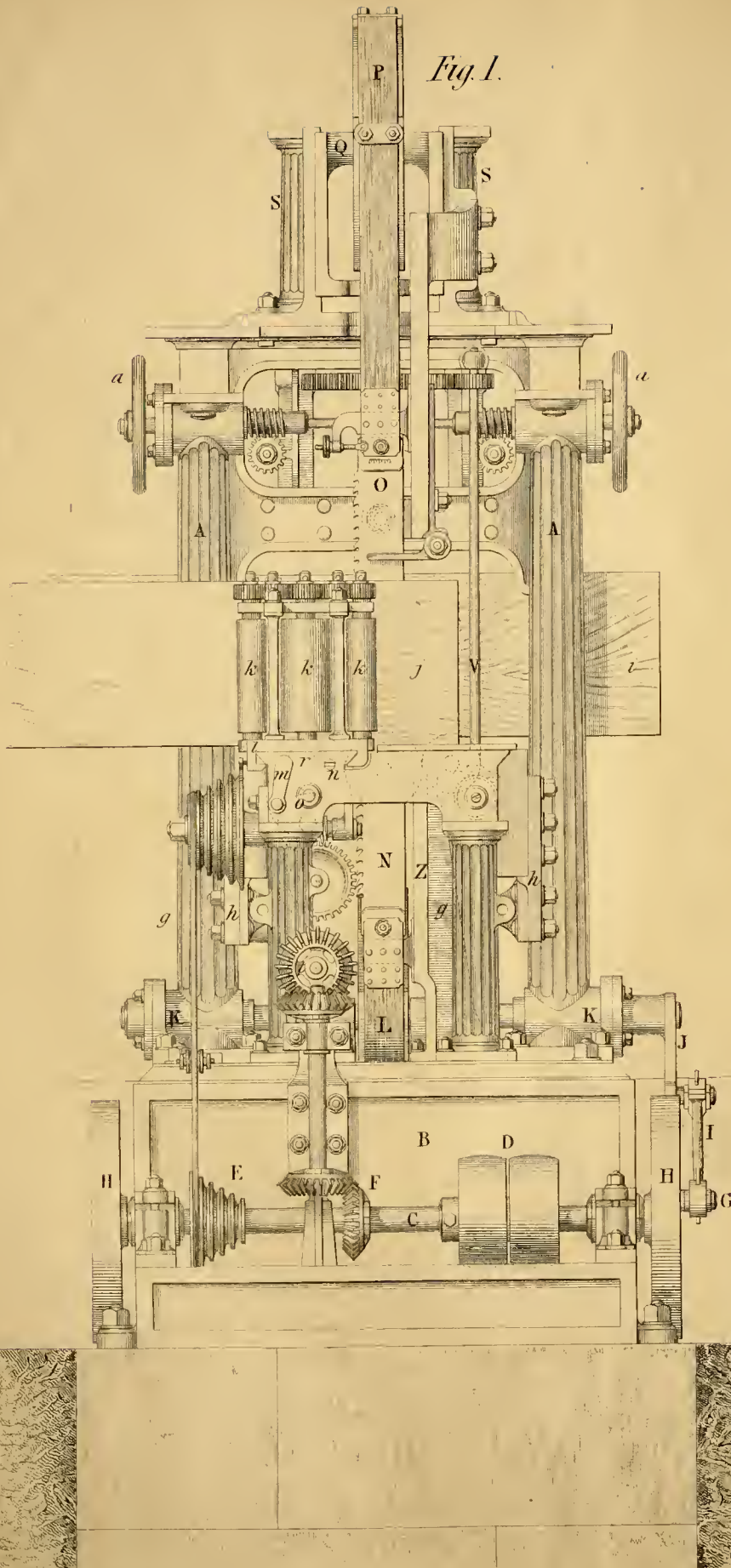

Fig. 1.

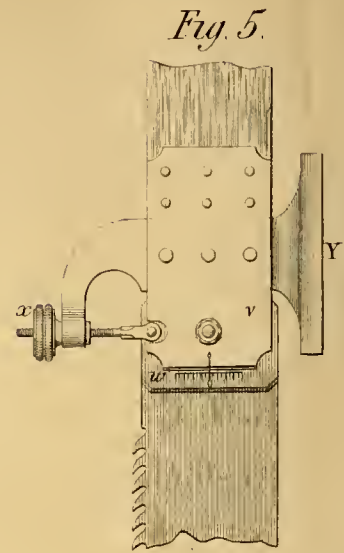

Fig. 5.

Fig.

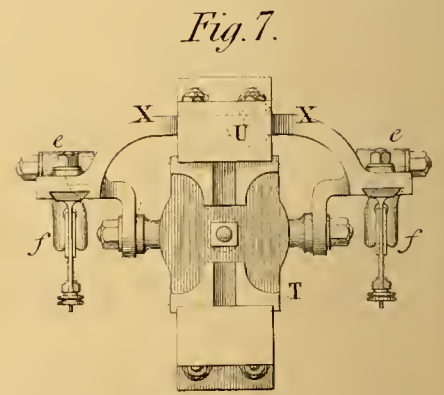

Fig. 7.

Floor Line

Scale for Figs. 1, 2, 3, & 7. 3/4 In. = 1 Foot
 Scale for Fig. 4. 1 1/2 In. = 1 Foot
 Scale for Figs. 5 & 6. 2 Ins. = 1 Foot

S. ENGINEERS, JOHNSTONE.

*Concise
My copy*

Fig. 2.

Fig. 3.

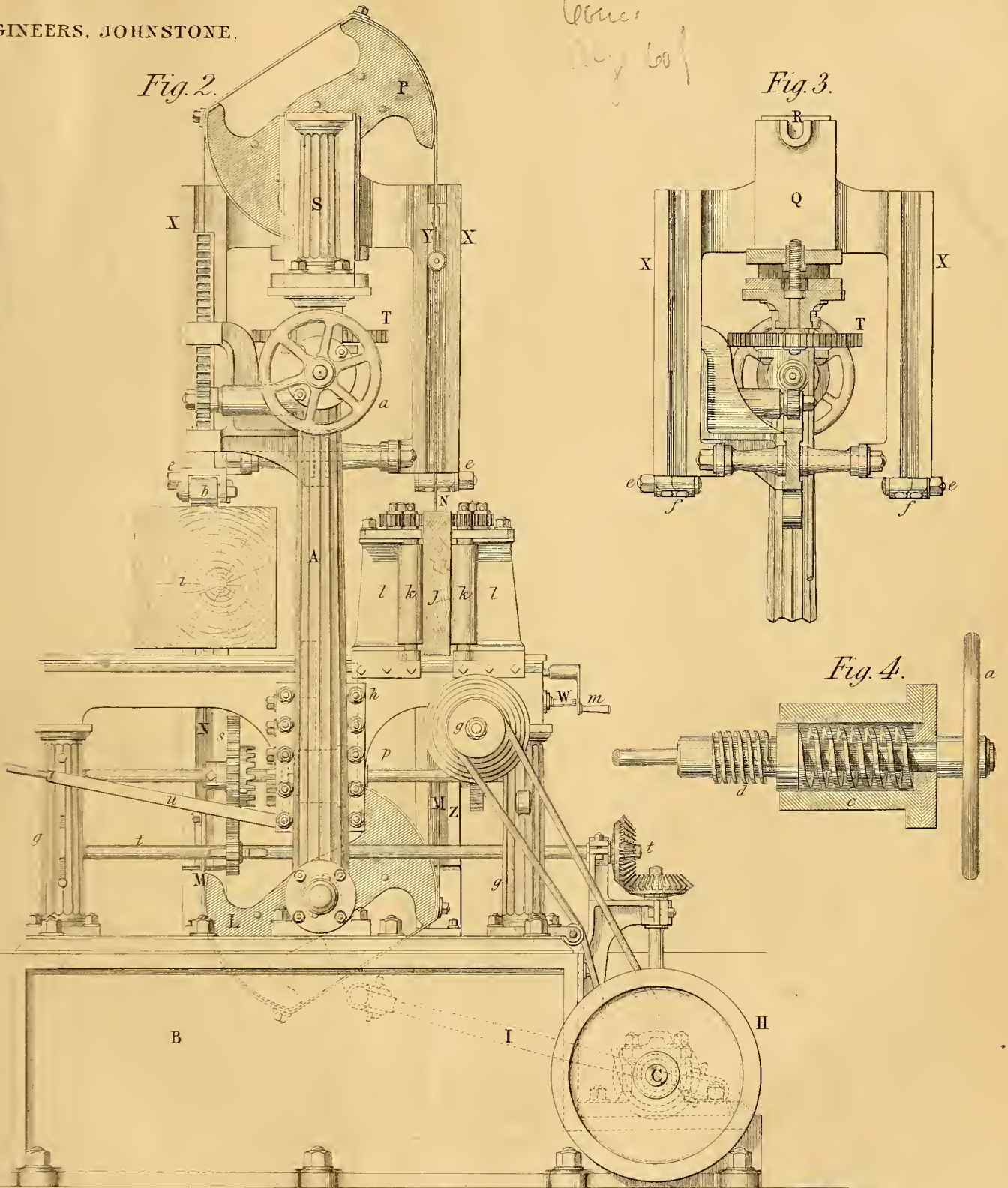



JOHN Mc DOWALL & SONS, ENGINEERS, JOHNSTONE.

10011

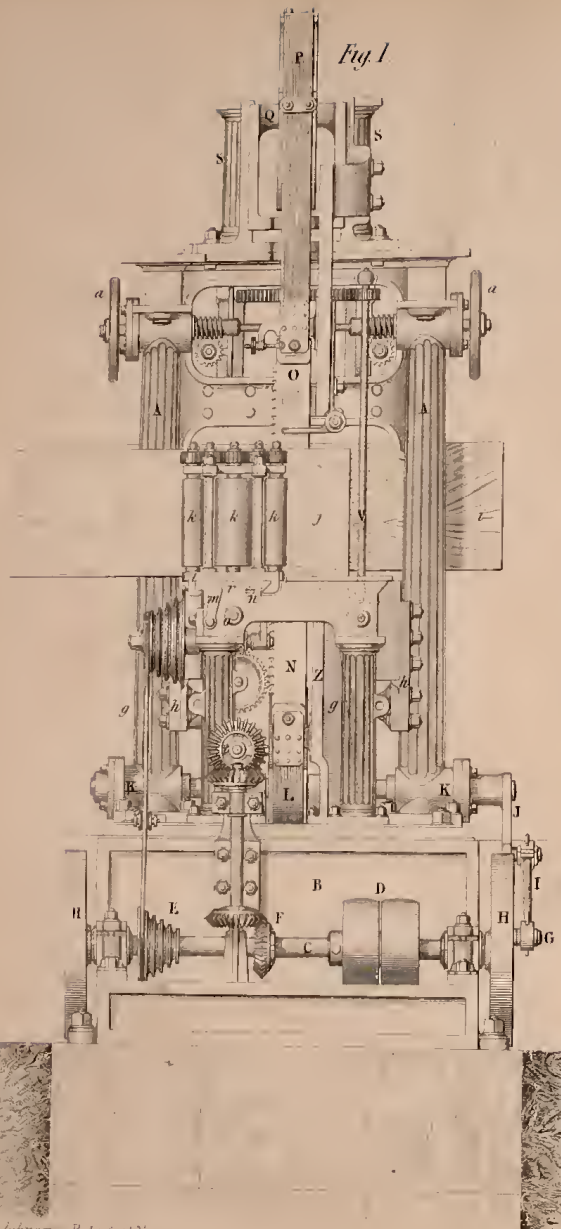

Fig. 1.

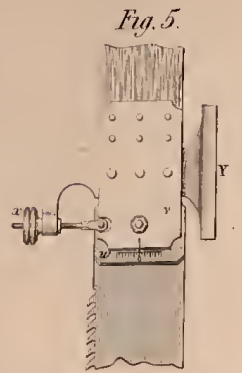

Fig. 5.



Fig. 6.

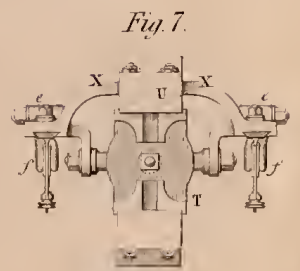

Fig. 7.

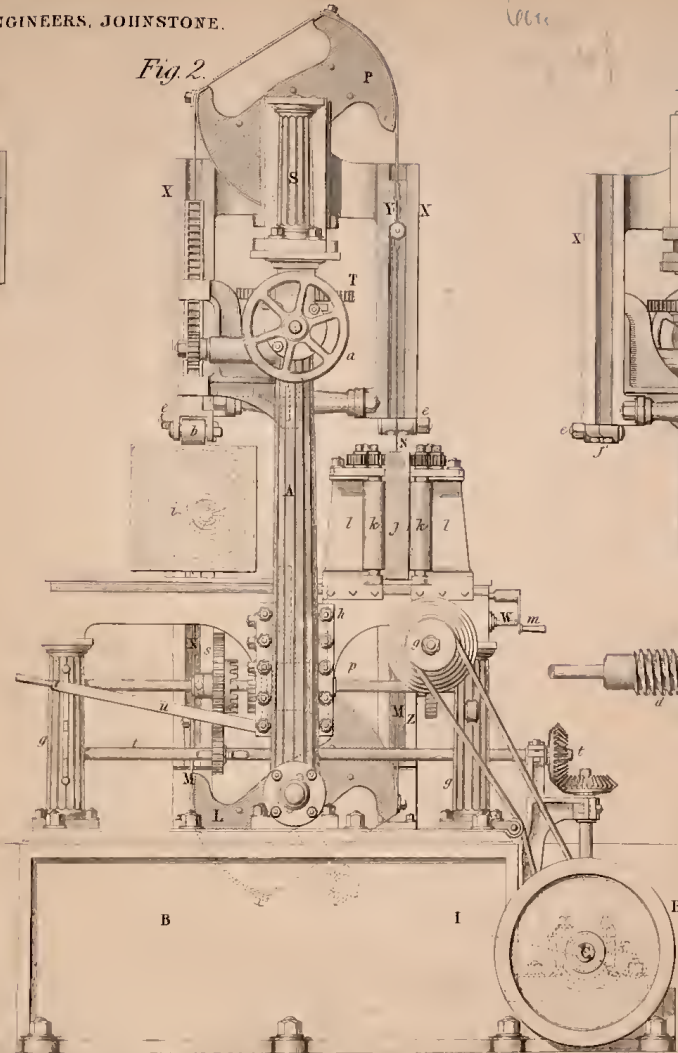

Fig. 2.

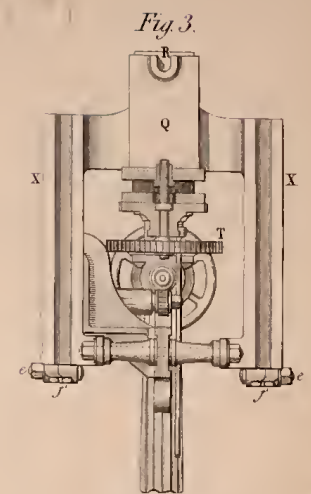

Fig. 3.

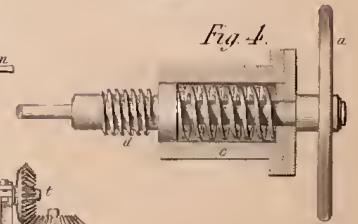

Fig. 4.

Floor Line
 Scale for Figs. 1 2 3 & 7 3/4 In. = 1 Foot
 Scale for Fig. 4 1 1/2 In. = 1 Foot
 Scale for Figs. 5 & 6 2 In. = 1 Foot

M'DOWALL'S HIGH SPEED TENSION SAWING-MACHINE.

By MESSRS. J. M'DOWALL & SONS, *Walkinshaw Foundry, Johnstone.**(Illustrated by Plate 123.)*

HAVING already given elaborate illustrations of Mr. M'Dowall's "Wood-Planing" Machine,* we now follow up our account of what that gentleman has done for the improvement of wood-cutting contrivances, by giving a still more elaborate plate of his recently-patented sawing machinery.

The leading essential feature of this invention consists in the so arranging sawing machinery, that an effective amount of tension may be given to the saw, without the necessity of using the ordinary heavy saw-frame and huckles; whilst the machine may be driven at a much higher velocity than has been usual hitherto, and the "rake," or "overhang," of the saw may be easily and accurately adjusted to suit the amount of feed given to the timber. By the existing mode of procedure, a whole log or haulk is usually cut up into planks or boards at once; a heavy frame being used, with as many saws set in it as shall give the required number of cuts. Loss frequently occurs from this system, by reason of the impossibility of judging, from external appearances, as to the actual state of the heart of the log, so that a number of boards are commonly lost in the centre, owing to the log being spongy or unsound at the heart. It is therefore desirable, in many cases, such as when the timber is intended for pattern-making, that the log should first be opened up the centre, in order to show how the wood is, and to enable the sawyer to cut it up in such a way as will best economise the material—laying the flat side against a "fence." But this single cut cannot be economically effected with the existing machinery, as loss would arise from working a single saw at the present slow rate which the heavy saw-frame involves. But Mr. M'Dowall proposes still to work in most cases with a single saw, driving it at such increased rate of speed as will enable the sawyer to perform as much, or nearly as much work, as when using a series or frameful of saws, whilst the machinery is exceedingly manageable, and may be readily adjusted or altered to suit various purposes.

Our plate, 123, furnishes seven detailed views of one branch of Mr. M'Dowall's latest improvements in this class of machinery—or the tools of conversion—wherein these points are practically carried out. Fig. 1 is a complete side elevation of the machine, showing a baulk of timber in the act of passing through. Fig. 2 is a corresponding front view at right angles to fig. 1, and looking on the cutting edges of the saws. Fig. 3 is a detached elevation of the upper adjustable tension apparatus and saw-guides. Fig. 4 is an enlarged longitudinal section of one of the hand-wheel arrangements for setting the holding-down apparatus. Fig. 5 is a side view, also enlarged, of the adjustable saw "huckle," for varying the "rake" of the saw; and fig. 6 is a corresponding edge view of the same. Fig. 7 is a plan of the upper saw-guides and adjusting movement.

The main framing, *A*, of the machine, consists of a pair of strong cast-iron columns, connected together by a cross-beam, and surmounted by an entablature, and carried upon a base or foundation plate, *B*. It is actuated by the main horizontal shaft, *C*, carrying fast-and-loose hand pulleys, *D*, receiving motion in the usual way. This shaft, together with many other details laid bare in our engravings, is entirely concealed beneath the floor, the level of which coincides with the upper line of the box foundation plate, or base, *B*. The latter has a short low projection cast on one side, serving to carry the two end pedestals for the shaft, *C*,

the movement of which is taken off by the cone pulley, *E*, at one end, the pair of bevel-wheels, *F*, near the centre, and the crank-pin, *O*, at the opposite end. Two fly-wheel discs, *H*, are carried on the shaft, to steady the action, and it is in one of these that the crank-pin, *O*, is fixed. From this pin a connecting-rod, *I*, passes up to a pin on the lever, *J*, fast on one end of a horizontal shaft, arranged to vibrate in hearings at *K*, in the lower portions of the two main pillars, *A*. This shaft has keyed upon its centre a double lever, *L*, with segmental ends, to the two opposite corners of which are attached the ends of a pair of flexible steel belts, *M*. These belts are respectively attached by coupling joints to the two lower ends of the pair of vertical parallel saws, *N*, the upper ends of which are again connected by adjustable huckles, *O*, with a corresponding pair of flexible straps fastened to the overhead double lever, *P*. In this way the two saws are formed into an endless belt, which, when kept up to the required tensional strain, answers, instead of the common frame, in keeping the saws up to their necessary steady working condition; and as the crank-pin, *O*, revolves, it communicates a rocking movement to the lower shaft, carrying the bottom lever, *L*, and from this, through the saw-belt, to the upper lever, *P*, overhead—thus giving the required alternate longitudinal traverse to the two saws. The short shaft of the upper oscillating lever, *P*, is carried in end bearings in the vertical slide-piece, *Q*, as at *R*, in fig. 3—this piece being fitted to traverse vertically between the two inner faces on the short pillars, *S*, cast together, and bolted down as a single standard upon the top of the entablature of the main frame. In the bottom cross-piece of the slide, *Q*, is a nut, through which works the upper screwed end of a vertical spindle, carrying a small spur-wheel, *T*, at its lower end—this spindle having a central collar, bearing on the fixed portion of the framing, to afford a bottom support. This wheel, *T*, has in gear with it a spur pinion, *U*, on the top of the shaft, *V*, passing down to the lower portion of the framing, where it is connected by a pair of bevel pinions, with a horizontal spindle projecting at *W*, to receive an adjusting lever key, which may be shipped on at pleasure for the purpose. By this means the attendant can at once set the upper lever, *P*, up or down, to give the necessary tension to the saw-belt, by turning the spindle, *W*. The saws are guided vertically by upper and lower guides on each side the main framing. The upper guides, *X*, are sustained by the overhead framing to which they are bolted; they have V groove faces to receive slide-pieces, *Y*, fast to the connecting huckles. The lower ends of the saws are similarly guided by the standards, *Z*, bolted down on the main base plate.

The hand-wheels, *A*, on each side, are for setting up and down the bearing pulleys, *B*, which press upon the baulk in passing through. The spindles of these hand-wheels pass through box-pieces, *C*, each containing a helical spring, abutting between one end of the box and a collar-piece fast on the spindle, the inner projecting end of which latter carries a worm, *D*, in gear with a worm-wheel fast on a spindle, carrying a spur pinion, gearing with a vertical rack on the upper part of the pulley-holder. In this way, by turning the hand-wheel, the sawyer can raise or lower his holding-down apparatus. The helical springs allow the bearing pulleys, *B*, to rise a little, when irregularities occur in the baulk surface; the worms, *D*, in such cases, acting as racks, by means of which the backward movement of the worm-wheels, due to the upward pressure of the baulk, forces the springs more or less into their box-pieces.

To the back of each of the guide-pieces, *X*, is fitted a smaller guide-piece, *E*, formed with projecting fingers, *F*, which embrace the saw, and steady it laterally during working; and being capable of vertical adjustment in grooves on the main guide-piece, *X*, to suit the various thicknesses of wood to be sawed, the steadying resistance it affords can always be brought as near to the point of greatest strain, or vibration, as possible.

The timber traverse apparatus, and fence and feed rollers, are carried on separate framing, supported by the four short pillars, *G*. This fram-

ing is set within the main pillars, *A*, and is steadied by means of flanges bolted to flanges, *h*, on these pillars.

The feed details are different on each side of the machine. The large baulk, *i*, is traversed upon horizontal rollers, whilst the deal, *j*, is passed between vertical fence and feed rollers, *k*. These vertical rollers revolve in bearings in slide-pieces, *l*, which work in dovetail grooves in the framing, like the slide-rest of a lathe. The inner slide, which carries the fence rollers, is set up to the required distance from the line of cut of the saw, by the handle on the projecting end of a screw, working in a nut attached to the under side of the slide. The outer slide, carrying the feed rollers, is set in a similar manner by a screw, worked by a handle fitting on its projecting end, *n*.

There are three rollers in each slide, the middle one being larger in diameter than the other two. The three are geared together by small spur-wheels overhead, so as to work in concert. Motion is given to the middle rollers by means of a horizontal shaft, *o*, carrying bevel-wheels gearing into corresponding wheels on the lower projecting ends of the roller-spindle. The bevel-wheels on the shaft, *o*, are fitted to it with a feather, so as to be capable of traversing along it to suit the different positions of the slides. The shaft, *o*, carries a spur-wheel, hid by the central part of the framing, in gear with another spur-wheel on the shaft, *q*, carrying a worm-wheel worked by a worm on the shaft of the cone-pulley, *g*, which last receives motion from the corresponding cone-pulley, *e*, on the shaft, *c*. The shaft, *p*, also gives motion to the feeding rollers for the haulk of timber on the other side of the machine. To effect this, it carries a spur-wheel in gear with an intermediate wheel, which again gears with a wheel on the end of one of the two horizontal rollers, *r*, carrying the baulk up to the saw. The two rollers are geared together, so as to work in concert; and they lie immediately below the two corresponding overhead pressure-rollers, *b*, already described. On the shaft, *p*, is also a loose spur-wheel, *s*, in gear with a pinion on the lower horizontal shaft, *t*, deriving motion from the main shaft, *c*, by means of bevel-wheel connections. The spur-wheel on the shaft, *p*, which gives motion to the horizontal rollers, *r*, is loose on that shaft, and is formed with clutch-pieces at each side, fitting into a corresponding clutch-piece fixed to the shaft, and to another fixed to the spur-wheel, *s*. Its boss is formed with a ring groove, to receive the forked ends of a bent lever, *u*, by means of which it can be made to gear with the shaft, *p*, or with the loose wheel, *s*—sufficient play also existing to allow of its being out of gear with both. The gearing just described is so arranged that the spur-wheel, *s*, revolves in a different direction to that of the shaft, *p*, and also at a quicker rate. It follows from this, that when the wheel working the rollers is in gear with the wheel, *s*, the rollers will be caused to traverse back the haulk of timber, and at a quicker rate than that required for the sawing action.

The speed of the feed action is easily adjusted by means of the cone pulleys, *e* and *g*, so as to suit the overhang of the saw, obtained by the adjustable buckle, represented on an enlarged scale in figs. 5 and 6. The end of the flexible strap of the vibrating lever has a metal plate, *v*, riveted on each side of it; these plates projecting beyond the edge of the strap, so as to embrace the stout piece of metal, *w*, fast on the upper end of the saw. These plates are connected by a bolt—a horizontal slot being provided in the inner one, *w*, to allow of lateral adjustment, which is effected by means of a small thumb-nut, *x*, working on a small screw jointed at the opposite end to the plate, *w*. The screw passes through an eye in, and the nut works against the curved projecting end of the slide-piece, *y*, which is also secured between the two plates, *v*. The front one of these plates has cut upon it, immediately below the adjustment bolt, a central line, serving as an index for a graduated scale on the plate, *w*. The saw is set to the required rake, after loosening the bolt, by turning the thumb-nut, *x*, in either direction, until the index line on the plate, *w*, stand at the proper point on the scale, when the bolt is screwed tight, ready for use.

This descriptive enumeration completes our notes of the series of improvements in plate 123. But Mr. M'Dowall has also introduced more than one other modification of his plan of tensional, framless saws, as well as some minor arrangements for obtaining a "silent feed" action of peculiar nicety and elegance. These several improvements—the result of the specially devoted attention of an engineer, who has unquestionably done more for wood-working machinery than any other individual improver of either past or present time—we shall hereafter present in a collected form.

LORD BERRIEDALE'S IMPROVEMENTS IN BRICK MACHINERY.

Lord Berriedale, who, amongst many other varieties of mechanical contrivance, has given much attention to clay moulding apparatus, has introduced a convenient plan for enabling the brick or tile moulder to clear the grid or screen of the clay chamber during the action of the machine, without in any way interfering with the moulding process, so that an open screen may be constantly submitted to the passing clay.

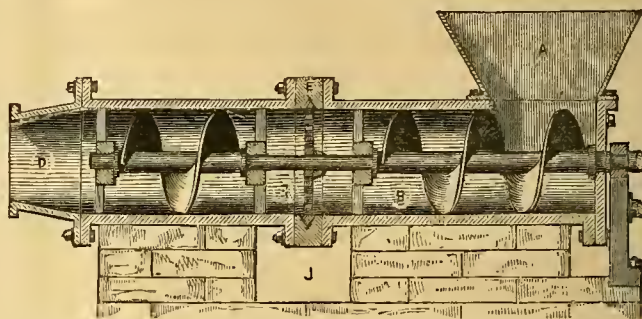

Fig. 1.—Side View of Brick Machine.

This object is effected in a very simple manner, by adjusting a traversing screen of greater length than usual in the centre of the clay chamber, as represented in our accompanying figures. Fig. 1 is a longitudinal section of a portion of a continuous brick-moulding machine fitted with this contrivance, and fig. 2 is a front view of the screen and its guide detached. The clay is supplied at *A* by a receiver in the usual way, and the crude mass is traversed along the chamber, *B*, by a broad screw, *C*,

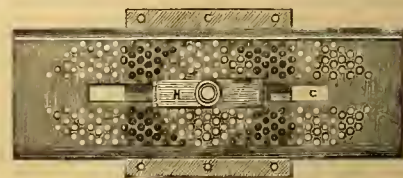

Fig. 2.—Face View of Brick Machine.

to act as guides for the traverse action of the screen, *F*. The screen is formed with top and bottom V-slide edges, to fit corresponding grooves in the guides, and it is about twice the length of the transverse section of the chamber, so that one-half may always be out of action. The screw-shaft is passed through its centre by a longitudinal slot, *G*, through which, however, the clay is prevented from passing by a stationary stop-piece, *H*, placed upon the shaft immediately behind the screen. This piece is shaped to a double incline on the feeding side, so as to impede the passage of the clay as little as possible; and as it extends over as much of the slot, *G*, as is at any time opposed to the clay, it preserves the operation of the screen uninjured.

The plan of working is pretty clear from the figures. When the screening apertures require clearing out, the attendant has simply to draw the screen plate far enough to one side along its guides, to present a set of clear openings to the clay, when those which have been choked will, of course, be laid bare for clearance, by passing through the holes a set of clearing-rods formed to fit the spaces. The screen may then be traversed back again to present a freshly-cleared surface. In fig. 2, the

central portion of the screen is in action, so that, if drawn to either side, one of the end portions will be put to use, whilst the central part may be cleared. The matters detected and retained by the screen are removable by the bottom aperture, *j*.

Fig. 3 is a side elevation of an arrangement, showing Lord Berriedale's system of severing the stream of clay into bricks, without any stoppage of the exuding material; and fig. 4 is an end view of the apparatus. The clay, *a*, is here issuing in three distinct lines, to produce three separate sets of bricks; and as these three streams are constantly passing at a uniform rate, whilst the cutting apparatus is stationary, or has no

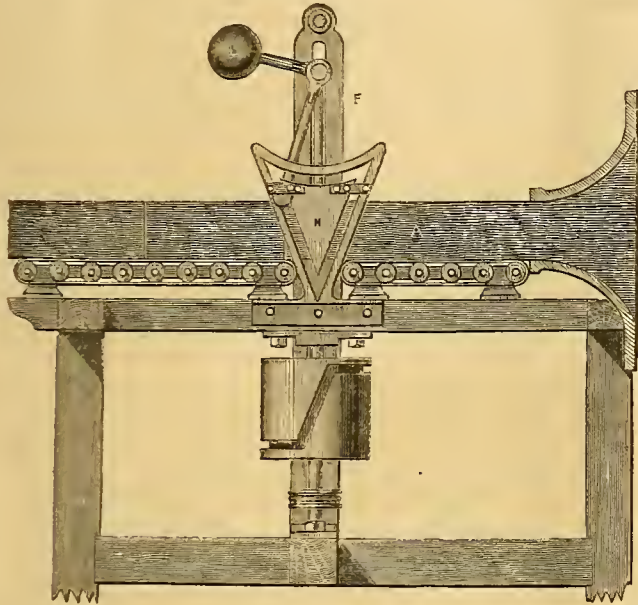

Fig. 3.—Side View of Cutting Motion.

horizontal traverse, it becomes necessary to proportion the rate of descent of the cutting wire, *b*, to that of the clay stream, that a clean vertical cut may be given, to produce square-ended bricks. This is ingeniously accomplished by giving the wire a differential action, through the agency of the two scroll cylinders, *c*. These scroll cylinders are driven simultaneously at a uniform rate, and they are each formed with a right

and left spiral inclined groove, joined by straight circumferential portions at each end. Into these grooves are fitted the pins, *d*, in the lower ends of a pair of connecting rods, which pass upwards to a cross-head, *e*, working in vertical guides, *f*. The same cross-head also has hung to it a pair of levers, *g*, having pins at their lower ends, fitting into the duplex inclined grooves of the fixed guide-pieces, *h*. The right and left inclines on the scroll cylinders, *c*, correspond to what may be termed the right and left inclines of the guides, *h*, the degree of inclination being exactly suited to the rate of the clay's motion, so that the wire may tra-

verse as much forward in cutting, both up and down, as will allow for the forward traverse of the clay. During the time a brick length is passing, the cutter remains stationary, as the plain circumferential portions of the grooves in the cylinders, *c*, are in action; but the moment the inclines come to bear on the pins, *d*, the wire, *k*, which is carried by the levers, *g*, is traversed down to make the cut, being guided along the back inclines of the pieces, *h*. On arriving at the bottom, the plain grooves at the lower ends of the cylinders, *c*, keep the wire stationary until another brick-length has passed, when the reverse inclines carry up the wire along the guide of the forward incline in *h*, so as to cut upwards in the same manner. The weight, *l*, then carries back the wire along the upper segmental grooves of the pieces, *h*, to the back position for a fresh stroke. Lord Berriedale at one time proposed to apply an arrangement of rollers to the mouth of the die, to polish the surfaces of the bricks, by revolving at a somewhat higher rate than that of the traverse of the clay, so as to give a slight rubbing action; but this plan he has now relinquished as more than doubtful. Indeed, except with certain qualities of clay, or with the clay at a certain degree of moisture, we are afraid the rollers would have a tendency to disintegrate and roughen the surfaces.

SOME ACCOUNT OF THE MARQUIS OF WORCESTER'S CENTURY OF INVENTIONS.

II.

No. 78, a watch going constantly after one winding up; it must be sometimes consulted, and the oftener the more true its response; as if, like a human being, its knowledge improved under catechising. Some have taken this for a perpetual motion, and so, perhaps, the reader was meant to do; but it is more probably a watch with a reserve of force charged in some way by lifting or opening it; the superior accuracy resulting from frequent use is perhaps mere generality. It was included in a patent obtained by the Marquis, and he says there that it may lie by several weeks; and further describes it as having no spring, chain, or windage up.

Another item enables even a child to stop a carriage he is in at once, and goes on to disclose this to mean a mode of releasing restive horses. There was a patent for this object in 1718, and also subsequently by Cook, the inventor of the life-buoy.

A winding staircase, enclosing another one in its noel, provides for servants or secrecy, but ordinarily the central space affords the light; as at Dover, three sets of steps are one over another, but occupying the same cylinder in point of horizontal section. Evelyn mentions a French staircase formed of four independent sets, but which he deems more remarkable for cost and difficulty than utility or pleasure.

A machine for drawing in perspective would be answered to by the camera, of which a description was extant, though little known at that time.

In contrast with the tendencies of invention in our day, we have two only assignable to manufacturing art. No. 83, a mill to rasp hartshorn, a child doing six men's work; a statement perhaps admissible, if the mill supplanted grating by hand. No. 87, a brass mould for candles; an invention attributed usually to the French, who might still have been the first to carry out the idea; the annals of early candle-making progress, however, are not easy to complete; its later history is well reviewed in the Crystal Palace Jury Report. The mould was to enable rapid and also superior production—it allowed the addition of an ingredient to the material, rendering it cheaper and more permanent. Water, which Partington suggests as to precipitate impurities in melting, could not lessen the price. Sulphuric acid has long been used abroad, and perhaps thus introduced here by his lordship, who probably did not himself practise chemical research. In the first edition, No. 88 was a coining machine; one man, without noise, knock, or fire, was in an hour to coin 100 lbs. The Marquis afterwards displaced it; perhaps on its becoming known that a fly-press, in lieu of hammering, was used for some years under Queen Elizabeth—its temporary user being fatal to the originality, as its discontinuance to the apparent value of the engine. That No. 88 was a fly-press, however, is matter of conjecture; such a machine is but comparatively without noise, and a hydrostatic press, which has been suggested, wants the alleged speed in operation.

Lastly, as to mechanical arrangements and sources of power, four articles relate to the screw of Archimedes: one being to make it transparent and not brittle, a purpose to which Pliny's malleable glass would have been suited, had the Roman inventors put his specifications on record. One Rochon, it seems, in some measure effected what is proposed, by woven or plaited wire saturated with clear glue. No. 14 is a substitute for an axle (capstan) at sea, enabling a small crew to weigh anchor, and in a confined space; for this purpose an arrangement of an endless screw was patented some time ago. No. 15, a boat to move at pleasure against wind and tide, or otherwise, having oars or propellers,

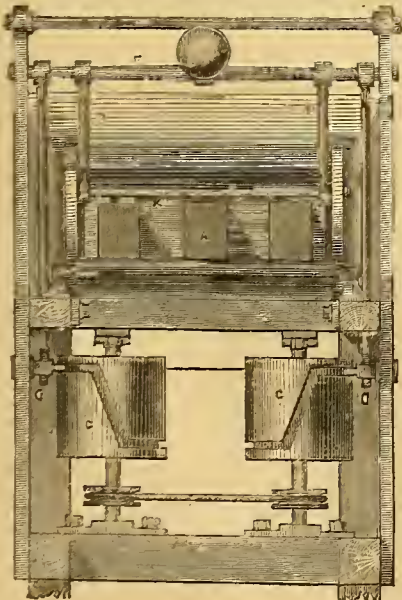

Fig. 4.—End View of Cutting Motion.

verse as much forward in cutting, both up and down, as will allow for the forward traverse of the clay. During the time a brick length is passing,

but unhelped by man or beast. Here, and in some other cases, it is not easy to perceive whether a new motive force be intended, or a conversion of power already acting. This, however, is decidedly not (as some construe it) an embryo steamer. It is more fully described in a patent of 1661, quoted by Woodcroft (*Steam Navigation*), which, on careful perusal, must be viewed as an *application* of force supplied by the wind and current; and a similar converter of wind-power was invented by one Desquignamere. No. 21, a hydraulic apparatus (avowedly borrowed from Clavius), is to make a weight that in ordinary cases takes up 100 lbs. to raise 200, and that at equal distance from the centre, and which, with some other points, is practicable, stipulating only for time in proportion. So of making 10 lbs. move 10 tons, as far on a level as itself falls vertically; which any suitable machine would do, unless the friction were excessive. By 94 a man shall raise, without stocks, a 500-ton vessel—which indeed he might do by the hydraulic press, or by bags gradually inflated, as in raising sunken ships. A Dutch invention is also compared with this, of a "camel" in two portions, to be brought under at each side the ship, the water pumped out, and thus raise it.

The three concluding articles are concerned about the great invention, the steam-engine; to have assisted in which is the proudest achievement of Lord Worcester, but for the general principle of which we must turn back to No. 68. "A most admirable way to drive up water by fire, not to draw or suck it in" (a far less available mode of action). He tells how he set about it: first he tested the power, bursting a closed cannon by heating the water within; then making his vessels of good proof, and to fill in succession with cocks, that as one is spent the other "begins to force and refill," the water shall run up continuously to a height of 40 feet. It is not easy to assign an exact shape and form to this description—the figure given by Stuart ('Anecdotes,' &c.) does not realize the expression, that each vessel in turn begins to force and refill; in his diagram, one would force and the other fill simultaneously. Whatever the apparatus, the aim clearly was to convert general expansion into a moving column of fluid, its actual attainment we will evidence forthwith; and it is strenuously maintained to have been thus first effected. Here, indeed, did raise enough water by steam-force to play sundry tricks, and his writings were known to the scientific of the time; it is clear, too, that others had been about applications of steam, as in pumping and navigation (see the patents in Woodcroft's treatise—Ramsay, for instance, in 1630, to raise water from low pits by fire); but no details remain to establish an accomplishment, and their non-adoption, unless explained, turns the balance of presumption against their success. True, the exigencies of the times left little leisure for such speculations, but historic rule must be adhered to in an account of discoveries, as in the law maxim, the non-apparent is as if non-existent. There is, however, an apocryphal narrative (see Scott Russell on *Steam Navigation*), which throws the Marquis, and all set up in competition with him, into the shade—a working steam-engine paddling a ship a league and more an hour; and this at Barcelona, before Charles the Fifth, a good century before. Substantiate this, and a Spaniard bears off the honour that America, France, and Great Britain dispute for. In reference to the present subject, the most formidable counter-claimant is De Caus, whose pretensions are as warmly supported by his Gallic compatriots as those of Papin against Watt in the matter of the condensing engine. His works were in circulation in France when Lord Worcester was residing there; but, in truth, as he was some time in the employ of Charles the First, the Marquis might well have acquaintance with his plans. The question is—whether these include the invention in the text? De Caus had (see 'Encyclopædia Britannica') a mode of raising water by expelling it from the boiler as this filled with the steam; he never contemplated continuous motion, nor is it probably capable of such adaptation. The expression in the text above indicates a boiler, and a recipient of the force there generated. One vessel of water rarefied, it says, drives up forty vessels; and thus harnessed, steam was, as we shall see, actually put to work.

No. 98 he designates a "semi-omnipotent engine." A model of this is to be the partner of his grave. By No. 99, one lb. raises one hundred lbs., the latter descending with the usual force. Both are by Stuart referred to the steam-engine, and, in some sense, the text confirms him, describing the last item as a steam water-work, and as founded on the two preceding it; but the former is rather a mechanical combination—a conversion of power. The text says, that however the *primum mobile* vary—backward, forward, &c.—yet the "pretended" operation is constant; and both it and the next article will be found in an appendant M.S., (see 'Stuart,') which expressly deals with combinations of what used to be called "the mechanical powers," comparing them to the compounds of the nine ciphers in arithmetic.

His last article is the crowning one—by which a child may raise water one hundred feet high and two feet (apparently in diameter).

This we must read as asserting it to be *governed* by a child's power; and its alleged silent working accords with its economy of repair. A book fully to set it forth is promised, and with "brass plates" of its structure; but the work never appeared, unless, indeed, it were swept away utterly by Savary, who is *accused* either of plagiarism, and of burning the copies of the store he had plundered, or, at least, to have in this manner made away with an earlier rival in the art of dealing with steam. If appreciation of results be an element in discovery, the Marquis is not behindhand: he, in an auxiliary essay, calls it the most stupendous machine in the whole world, yet—as steered by a helm, and a bit and bridle (the metaphors clash a little)—ruled by a child, but of power to supply the place of man, beast, wind, or mill; then it is capable of employment for pumping water away, or supplying it for mines, irrigation of land, and water-works for towns; for making rivers portable (portative), and a multitude of other objects; for "whosoever is master of weight (of water raised) is master of force, whosoever is master of water is master of both." Whether *his* boiler would have proved such a cornucopia is questionable, but on one head its practical success is now beyond the reach of dispute. He obtained an act in 1663, for a privilege in erecting water-works, and though no trace of these is known in any English authority, Stuart has obtained from the diary of a foreigner a notice clearly in point. Cosmo de Medici, a visitor here in 1699, was shown an engine at Vauxhall, as on the Marquis of Worcester's design; it was worked (managed) by one man, raised the water forty feet, and being of superior efficiency to another engine moved by two horses, must have derived its power from some artificial source. What would be otherwise thought too marvellous, the above-mentioned inventions account for.

What now shall we say of the chapman, after looking through his wares, which were set forth to win parliamentary patronage! In his own day, though attracting notice—for seven committees sat on his water bill—his fortune while living seems to have been that of the inventor—neglect. His memory has encountered both eulogy and contempt, the 'Century' being with Lord Orford "an amazing piece of folly," and with Hume "a ridiculous compound of lies, chimeras, and impossibilities." Nor, indeed, is such language unprovoked by his barely honest enigmas, the extravagance of his statements, and his puffing introduction, the whole composition redolent of the busy charlatan; but others, better qualified to sit in judgment on scientific questions, have arrested such easy indiscriminating censure. An able contributor to steam literature calls him illustrious—a man of genius; and to this side, opinions at present more generally incline. Were nineteen-twentieths of his schemes either trivial or delusive, it would not disqualify him from honourable remembrance. His exaggerated views, his false theory, his credulity in his perpetual motion and flying experiments, passing even, as often happens, into quackery, are akin to inventorship, and not to be coldly compared with the dealings of ordinary routine. It was by wandering out of the straight path that he came upon the steam-engine, perceived its pre-eminence, and made it a reality.

A still nicer point to define is the degree of originality—of absolute creation—in reference to what he began on, compared with what he left. He professes not to set down the inventions of other men, speaks sometimes of experiments, and of being led on by degrees. In his preface, he appeals not only to past deeds, but to present capacity:—"No good spring but becomes more plentiful by how much more it is drawn, and the spinner to weave his web is never stinted, but further enforced." And the sincerity of his attribution of the success to himself, is evidenced by a document (see Partington's edition), addressed only to One whom none think to deceive—a thanksgiving for the inspiration that led him to the water-engine, and a prayer to be guided in using it for his and others' good. Many of the inventions are such as his eventful life, his military and political position, may have suggested the want of, and mode of satisfying. Exile and imprisonment also had afforded leisure for working them out: there is a story of his watching a pot-*bd* raised by the steam in his apartment in the Tower. He states that he had been engaged in such pursuits for thirty-five years, and had at that time expended some ten thousand pounds. Others, it is true, had cultivated such branches of science; ancient topics had been revived, and foreign ideas introduced; useful art was more appreciated, and therefore improved. Again, on the practical side, the Marquis admits his obligation to Kulloff—in execution only, it is true; but, however strictly we take this, he must constantly have modified as he worked out his master's instructions. But if the Marquis only embodied the theories of the day, and controlled to that object the labours of his workman, he must, upon principle, receive the iron crown of the inventor—the triumphal honours of subjugating a province of natural force to the empire of art. That he *did* construct a steam-engine rests on undisputed coincidence—that he *first* did so, was publicly affirmed and uncontested.

THE SIMPLE MACHINES, OR MECHANICAL POWERS.

The simple machines, or, as they are commonly termed, the mechanical powers, are usually said to be six in number, viz.: 1. the Lever; 2. the Wheel and Axle; 3. the Pulley; 4. the Inclined Plane; 5. the Wedge; and 6. the Screw. However, as it is evident that the wheel and axle is merely a practical modification of the lever, both being identical in principle, whilst the wedge and the screw are really inclined planes, many mechanics have reckoned but three powers. That even the latter modified enumeration should have been countenanced so long would be a matter for surprise, were it not probable that the very elementary character of the case has prevented men of elevated theory from completely investigating it; while, on the other hand, practical men pass it over as unimportant. But as it is undeniable that the series should be developed and classified in an orderly manner, the following remarks are offered with this view.

The elementary machines, or mechanical powers, on one or more of which all machines are based, appear to be these five: 1. the Lever; 2. the Incline; 3. the Toggle, or knee-joint; 4. the Pulley; and 5. the Ram—of which latter class, the hydraulic press (more aptly named the Bramah press, after its inventor) is the chief representative. The series are classed in order; the second and third, and also the fourth and fifth, having a respective affinity, as we shall see presently.

The lever is commonly divided into three orders, or classes. The first kind is when the fulcrum, *F*, fig. 1, lies between the power, *P*, and the resistance, or weight, *R*; the distance, *P F*, being greater than *F R*. A

Fig. 1.

Fig. 2.

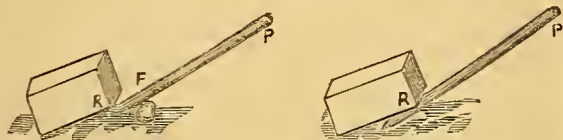

crow-bar, when applied as shown in the first figure, is a lever of this class, which is a very numerous one. Steelyards, scissors, and the reverse or vacuum safety-valves of low-pressure boilers, are also good examples. The second order embraces those cases in which *R* lies between *P* and *F*, as when a crow-bar is applied, as shown in fig. 2. Fig. 3

Fig. 3.

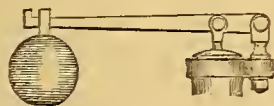

represents the common external or pressure safety-valve of steam-boilers, which belongs to this class—oars of boats, nut-crackers, and the treadles of lathes, as commonly constructed, &c., might also be instanced. We now come to the third order, which it will be seen cannot with propriety be included as a power, that is to say, as a means of overcoming a greater resistance by a proportionally prolonged exertion.

This class, of which the human arm is commonly named as the type, and of which the pendulum of a clock, fig. 4, is also an excellent example, differs from the second in the power being applied between the fulcrum and the resistance. Now, it is evident from these premises, that the human arm, the pendulum, and machines of their class, are merely inversions of the second order of levers, in which the power and resistance change places, the muscle of the arm acting disadvantageously in raising a weight; the power, *P*, requiring to be greater than the resistance, *R*, but *R* moving through a proportionally greater space, or with greater velocity. Hence, levers of this class have been termed *losing* levers.

Thus we arrive at a natural distinction, or second series, which we shall trace throughout, terming them—for want of a better name—mechanical *speeds*, inversions of, and antagonistic to, the *powers*, the places of *P* and *R* being simply interchanged.

There are, then, two classes of power-levers as described above, as the first and second orders respectively, and two corresponding orders of speed-levers. A familiar example of the first order of speed-levers occurs in the schoolboy's "cat," which, as is well known, is a cylinder of wood tapered at the ends. When the end, *P*, fig. 5, of the "cat" is struck a smart blow through the very short space intervening between it and the ground, as *P R* is here much greater than *F R*, the former, in its quick passage through a large arc, acquires sufficient momentum to raise the toy to a considerable height in the air. The tilt-hammer, and those used

in the forging of bolts, nails, &c., (such as fig. 6,) are other examples, Scissors with long proportionate blades, when cutting near the points, are also of this class of speed-levers, as distinguished from the pendulum shown before in fig. 4; the lever pyrometer for measuring the expansion of heated metals, garden shears, fire-tongs, the treadle of a knife-grinding machine, which are speed-levers of the second order. Bent-levers have been sometimes enumerated as a fourth class, but they may obviously be resolved into one of the two former kinds of powers and speeds.

Fig. 5.

Fig. 6.

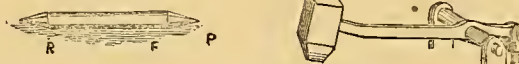

A claw or kent hammer, fig. 7, in drawing a nail, illustrates a power bent-lever of the first order; the hammer of a house-clock, when raised by the pin-wheel, fig. 8, a speed bent-lever of the same class. From the nature of the case, bent-levers of the second class cannot be distinguished from those of the first. As before stated, the wheel and axle—which embraces wheelwork of most kinds, and windlasses—is merely a modification of the lever. It has been aptly termed a *perpetual* lever; and the distinction between a power and a speed-lever will be here equally as apparent as in the simple form; for instance, between a crane-movement and a watch-movement respectively. A humming-top, also, exemplifies a speed-wheel and axle. The lever has necessarily a radial motion, as distinguished from some cases of the other powers; and unless both power and resistance be applied tangentially, an increasing or diminishing effect will be obtained, as is exemplified in the action of gravity on the bent-lever safety-valve. This principle, when judiciously introduced, is serviceable in overcoming the *inertia* of mechanism. The fuseses of watches and spring-clocks, and eccentric-toothed gearing, are instances of the application of the wheel and axle to produce a varying effect.

The second power is the incline. We do not call it the inclined plane, because this would not apply in many of its most important applications—as curvilinear inclines in cams, snails, spirals, and Gwynne's *Rolling Incline Movement*, for example. To this class

Fig. 7.

Fig. 8.

Fig. 9.

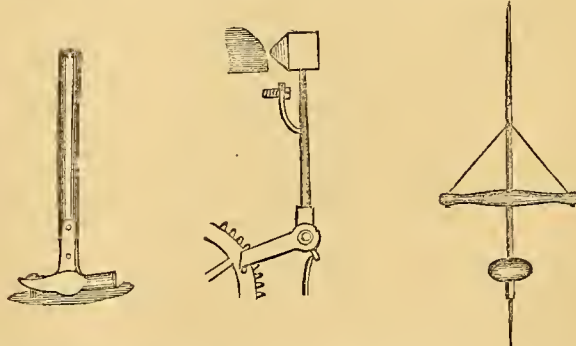

belong edge-tools, wedges, &c. A conical or taper "drift," used to enlarge or "open" a hole, is another illustration. An incline wrapped round a cylinder, or cone, generates a screw. The conical screws of augers and gimlets, and the pointed helices of cork-screws, combine the screw with the direct incline. The sliding rings employed to compress the springs of rat-traps, and watchmaker's sliding-tongs, the rudders of ships, and vanes or weathercocks, illustrate a radial variety of the incline, the power of which equals the resistance when the arms subtend an angle of 90°—increasing to infinity as they approach parallelism. Since, from our premises, an inversion of a power becomes a speed—the positions and velocities of the power and resistance being interchanged—the contrast between power and speed inclines becomes evident; as, for instance, in the motion of a train of carriages up and down a slight incline, considered in relation to the force of gravity. A kite rising from the ground, the sails of a ship and windmill, are instances of speed inclines, when making any angle less than 45° with the plane of their motion. In practice, it frequently happens that the result is defeated by the excess of load put upon the machine; but the principle is not impaired, as will be illustrated by the ventilators fixed in windows, and the windmill toys of children, which, being free to revolve on their axes, move at a much greater velocity than the power applied. The Archimedean drillstock, fig. 9, is an example of a speed application of the screw—

its uses as a power do not need illustration. The force may be applied either to the screw or box, and either in the direction of the axis or the plane of rotation; giving, in any case, either a power or a speed according to the pitch. Screws are frequently applied tangentially to screw-wheels as powers, and also as speeds; as, for instance, in driving the shafts of thrashing machines, and the flies of musical boxes, at high velocities. They are then termed *endless screws* or *worms*; or, more correctly—according to the systematic nomenclature used by mechanicians of the modern school—"tangent screws." The great friction inseparable from the application of the incline in many forms—and on which its successful use in practice, in preventing retrogression as a power, frequently depends—interferes, however, in many cases, with its advantageous application as a speed where great strains exist. The third power, the toggle, has been described by Moffatt, as the "machine of oblique action." It is here termed the "toggle," from the "toggle joint" (fig. 10), one of its principal and most energetic applications, and in accordance with the simple names of the other powers. Deflected strings (fig. 11) and rods, Medhurst's printing-press motion (fig. 12), and the crank movements

Fig. 10.



Fig. 11.



Fig. 12.



applied to many machines for shearing and punching metal, belong to this class, which has many practical varieties. The bones of the leg form a toggle, jointed at the knee, which we exert in lifting. The crank is, in fact, a circular application of the toggle, having no leverage when the power is applied to the crank-pin in its circle of rotation. It is owing to the existence of this power that thin plates are so easily deflected when

Fig. 13.



flat, and that two tightly-fitting pieces, placed end to end, are simultaneously forced, or "trapped," into their places with facility. This power is forcibly applied in Fairbairn's Patent Riveting Machine. A bow and arrow, fig. 13, and lazy-tongs, fig. 14, are familiar examples of the application of the speed-toggle; the crank in a steam-engine, when approaching the dead points, is another instance. The toggle has an affinity to the incline in acting obliquely, and in its circular applications, as shown in a screw and twisted cord respectively: each is frequently used in practice in conjunction with the lever. The latter is used by carpenters to stretch their saws in frames, fig. 15, as the screw is by smiths. Twisted chains are used

to draw together the sides of a boat, when this is necessary, before fixing the

Fig. 14.



cross seats, or "thwarts;" and the traveller will have noticed the wire stays used to support the telegraph posts round curves in the railway, which are tightened by twisting. A simple circular application of the speed-toggle occurs in the school-

Fig. 15.

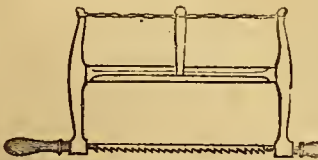

boy's toy, in which a perforated disc (commonly a heavy button) is spun with great velocity by a twisted thread, fig. 16, extended between the hands, which are dexterously moved a short space between each stroke, the momentum communicated to the disc having sufficient power to wind the thread up for the return. The Ceylonese drill-

Fig. 16.



stock, fig. 17, is a more refined example. The useful effect of the toggle, as a power and speed, obviously varies between *nil* and infinity, according to the angular position of the parts, and the direction in which the force is applied; hence it is a most energetic machine, within narrow limits. It is owing to this property that large carriage wheels pass more easily over obstacles than smaller ones.

The fourth element is the pulley, too well known to need a detailed description. It has sometimes been called "the flexible cord;" but this term is lengthy, and, perhaps, less suggestive, and would clash with one of the forms of the toggle above

described. The pulley or the arc seems, in fact, an inseparable feature in the practical application of this power, without which the friction would be very severe. The chief uses of the pulley occur in the rigging of ships. The sheaves rising with the weight are alone effective, the others being merely converters of the direction of motion; hence it is frequently contrived that the latter should be in excess. Speed pulleys are illustrated by a clock line, fig. 18, in which the descent of the weight through half the space causes many revolutions of the barrel. But a power pulley is exerted whilst winding up. In the applications of pulleys, the cords are always supposed to be parallel; otherwise, in estimating the effect, an allowance would have to be made for the influence exerted by the oblique power last described.

Fig. 17.



Fig. 18.



The fifth and last elementary machine in our list is the ram, or, in its chief application, the Bramah press. At first sight this would appear to be a hydraulic power, or machine; but, on investigation, it will be found to obtain more or less in most cases of ramming, stuffing, or packing, as in stuffing a sack through a small orifice till it bursts. The highest practical results are, of course, obtained with fluids, because of the freedom with which their particles are moved—water being generally adopted for cheapness and convenience. Fluid metals would of course answer perfectly, and the existence of this power may be readily demonstrated with a number of shot. Indeed, mechanics being the laws of matter in motion, the laws of fluids are, of course, one of its natural branches, though generally distinguished from motives of convenience. In the stupendous lift of 1800 tons at the Britannia Bridge, the ram has, in fact, laid claim to be considered the chief mechanical power, surpassing in its practical results the famous lever of Archimedes. Besides, on close examination, this power will be found to be very closely allied to the pulley—hence our arrangement of these two consecutively—the chief difference being, that the former acts by compression, the latter by tension. Each is based on the *division of the points of support*; for the proportionate area of the piston in the Bramah press represents the number of points over which the pressure is diffused, or on which the weight rests. The common syringe, or squirt, illustrates the speed-ram, in which a slow motion of the piston projects the water, with considerable velocity, to some distance, through a proportionally narrow orifice.

The useful effect of any of the powers or speeds is at once given by the law of *virtual velocities*, or the ratio of the space passed through by the power and resistance respectively—*space* and *speed* being here, from the nature of the case, convertible terms. This rule, of course, supposes the absence of friction and the interference of gravitation, and perfect elasticity in cords, which cannot occur in practice, and for which a reduction must be made. The power of the pulley is always equal to twice the number of sheaves rising with the weight, because each hangs on two supporting lines. If time and space permitted, the series of elementary machines might be traced, as powers and speeds, through their differential and complex modifications, as exemplified in differential wheelwork, the Chinese windlass, Dr. Wollaston's perambulator, Shanks' drillstock, Hunter's screw, and others; but we trust enough has been adduced to show the reasonableness of our classification, and the harmony which prevails throughout the distinctions we have offered. It is very possible that, by pursuing the investigation further, some new practical applications might be suggested, which have been hitherto wanting to complete the groups.

A beautiful instance of the differential application of the lever may be hastily alluded to, occurring in the crank of a locomotive, which differs essentially from its simple application to a fixed engine.

If we take the position at half-stroke, shown in fig. 19, F is the rolling or perpetual fulcrum, A is the power applied by the piston to the crank journal, B is the same power applied by the cylinder cover to the bearing of the wheel. Now, as B F is greater than A F, the machine must move forward, the reverse action taking place when the crank is at top, and the proportionate leverage being different. In the selection of our illustrations, we have given, as far as possible, the simplest and most forcible examples, and those which we conceived to be most generally understood.

Fig. 19.

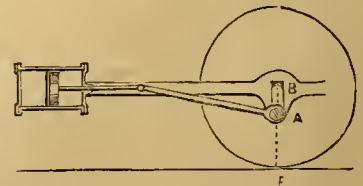

THE LAW OF THE UNITED STATES OF AMERICA
RELATING TO PATENTS FOR INVENTIONS.

This law is enunciated by certain acts of Congress,* by which a patent office, attached to the department of State, was established; the chief officer of which is called the Commissioner of Patents. He has, for subordinates, a machinist and various clerks. All patents are issued in the name of the United States, and under the official seal, signed by the secretary of state, and countersigned by the commissioner. Every patent must contain a short description or title of the invention or discovery, correctly indicating its nature and design, in its terms granting to the applicant or applicants, his or their heirs, administrators, executors, or assigns, for a term not exceeding fourteen years,† the full and exclusive right and liberty of making, using, and vending the said invention or discovery, referring to the specifications for the particulars, a copy of which must be annexed to the patent, specifying what the patentee claims as his invention or discovery.

Before an inventor can apply for a patent, he must pay into the treasury of the United States—

If an American citizen, or an alien resident for a year previously in the United States, and making oath of his intention to become a citizen,	30 dollars.
If a British subject,	500 "
Any other person,	300 "

The persons applying for a patent must have discovered or invented some new and useful art, machine, manufacture, or composition of matter, or some new and useful improvement on any art, machine, manufacture, or composition of matter, not known or used by others before their discovery or invention thereof, and not, at the time of the application for a patent, in public use or on sale with their consent or allowance as inventors or discoverers.

Application in writing must be made to the commissioner of patents, expressing a desire to obtain an exclusive property in the invention; and the inventor must deliver a written description of his invention or discovery, and of the manner and process of making, constructing, using, and compounding the same, in such full, clear, and exact terms, avoiding unnecessary prolixity, as to enable any person skilled in the art or science to which it appertains, or with which it is most nearly connected, to make, construct, compound, and use the same. In case of a machine, he must fully explain the principle, and the several modes in which he has contemplated the application of that principle or character by which it may be distinguished from other inventions; and must particularly specify and point out the part, improvement, or combination which he claims as his own invention. If the case admits of drawings, then drawings and written references must accompany the specification; and when the invention is of a composition of matter, specimens of ingredients, and of the composition, must be delivered. Moreover, when the invention admits of representation by model, he must furnish a model of a convenient size to exhibit advantageously its several parts.‡ The applicant is likewise required to affirm, in a formal manner, that he verily believes himself to be the original and first inventor or discoverer of the art, machine, composition, or improvement, and that he does not know or believe that the same was ever before known or used.

The duty being paid, and the application, description, and specification being filed, the commissioner proceeds to examine the alleged invention.

If the commissioner does not deem the invention to be sufficiently useful and important, he is empowered to reject the application.

If it appears to the commissioner that the applicant was not the original and first inventor, or that any part of that which is claimed as new had been previously invented or patented, or described in any printed publication in America or any foreign country§ prior to the alleged invention by the applicant, or that the description is defective and insufficient, he shall notify the applicant thereof, giving him briefly such information and references as may be useful in judging of the propriety of renewing his application, or of altering his specification to embrace only that part of the invention which is new.

* The acts of which this paper is an epitome were passed July 4, 1836, March 3, 1837, and March 3, 1839.

† It is usual to grant a patent for the full term of fourteen years.

‡ This regulation might be beneficially introduced into our law. In America, the models, specimens of compositions, fabrics, and manufactures, received from applicants for patents, are classified and arranged in a suitable building, and are open to the examination of the public. There are agents of the patent office in the principal cities, specially appointed for the purpose of receiving and forwarding to the office all models, specimens, and manufactures delivered in.

§ This provision goes beyond our law, which only declares a patent to be invalid for want of novelty, by reason of a publication of the invention in a printed book, when the book has circulated in Great Britain.

If the applicant shall elect to withdraw his application, relinquishing his claim to the model, he shall be entitled to receive back 20 dollars, part of the duty paid in. But if he shall persist in his claim for a patent, without modifying the specification and claim so as to entitle him to a patent in the opinion of the commissioner, the applicant may obtain the decision of a board of examiners, composed of three disinterested persons appointed for that purpose by the secretary of state. Such board, after examination and consideration of the matter, has power to reverse the decision of the commissioner, either in whole or in part; and its opinion being certified to the commissioner, he shall be governed thereby in the further proceedings to be had on such application.

If the application rejected or withdrawn for want of novelty be a foreigner's, he shall be entitled to receive back two-thirds of the duty paid into the treasury.

Whenever the commissioner thinks that any application would interfere with any other patent for which an application may be pending, or with any unexpired patent, he shall give notice thereof to the applicants or patentees, who, if dissatisfied with the decision of the commissioner on the question of priority of right or invention, may appeal from such decision to a board constituted as before mentioned.

An inventor shall not be deprived of a patent by reason of his having previously taken out a patent in a foreign country, and the invention having been published at any time within six months next preceding the filing of the specification and drawing. No person will be debarred from receiving a patent by reason of the invention having been patented in a foreign country more than six months prior to the application.

At the request of the applicant, the patent may be dated from the time of the filing of the specification and drawings; not, however, exceeding six months prior to the actual issuing of the patent; and, on like request, and payment of the duty, his specification and drawings shall be filed in the secret archives of the Office, until he shall furnish the model, and the patent be issued, not exceeding the term of one year, the applicant being entitled to notice of interfering applications.

In case of the death of an inventor before obtaining a patent, the right of applying for the patent devolves upon his executor or administrator, in trust for his heirs-at-law, in case he died intestate; but if otherwise, then in trust for his devisees.

Every patent is assignable in law, either as to the whole interest, or any part thereof. Assignments, and grants of exclusive rights under a patent, must be recorded in the Patent Office, within three months from the execution. The assignee of an inventor may have the patent granted to him directly, the assignment being first entered on record; but the application must be made, and the specification sworn to by the inventor, in the usual way.

Inventors who are American citizens, or aliens resident for a year in the United States, having made oath that they intend to become citizens, may, on paying to the credit of the Treasury the sum of 20 dollars, file a caveat setting forth the design and purpose of his invention, and its principal and distinguishing characteristics, and praying protection of his right till he shall have matured his invention. The money so paid will be considered as part payment of the duty payable on taking out the patent. The caveat will be filed in the confidential archives of the Office, and preserved in secrecy. Should application be made within a year for a patent of any invention with which the one referred to in the caveat may, in any respect, interfere, the commissioner will send notice of such application to the person filing the caveat, and he is bound within three months after receiving the notice, if he would avail himself of the benefit of his caveat, to file his description, specifications, drawings, and model. If, in the opinion of the commissioner, the specifications of claim interfere with each other, then similar proceedings may be taken as are provided in the case of interfering applications.

Persons interested in or against a patent are not precluded, by any decision of a board of examiners, from the right of contesting the same in a judicial court.

A patentee desirous of adding the description and specification of any new improvement of the original invention subsequently made by him, may, by taking proceedings similar to those required on making original applications, including the obtaining of the commissioner's approval, and on payment of 15 dollars, have the same annexed to the original description and specification; and the same, thereafter, will have the same legal effect as if embraced in the original description and specification.

If a patent be inoperative or invalid, by reason of a defective or insufficient description or specification, or by reason of the patentee claiming in his specification as his own invention more than he has a right to claim as new, (the error having arisen by inadvertency, accident, or mistake, and without any fraudulent or deceptive intention,) the commissioner, upon the surrender to him of such patent, and the payment of the further duty of 15 dollars, may cause a new patent to be issued to the inventor

for the same invention, for the residue of the period originally granted, in accordance with the patentee's corrected description and specification, subject to the examination and approval of the commissioner. The effect will be as if such corrected description had been filed in the first instance. If the patentee desire several patents to issue under this law, for distinct parts of the thing originally comprised in one patent, he must pay the sum of thirty dollars for each additional patent.

A patentee having erroneously made his specification of claim too broad, may make disclaimer of such parts as he wishes to abandon; and such disclaimer being entered of record, will afterwards be considered as part of the original specification.

Patents, however, will not be vitiated where the inventor has by mistake, and without any wilful default or intent to defraud or mislead the public, claimed in his specification to be the original and first inventor of any material or substantial part of the thing patented, (clearly distinguishable from the other parts,) when, in reality, he was not the first and original inventor. In such a case, the patent will be valid for so much of the invention as shall be truly and *bona fide* the inventor's own. But to entitle him to recover costs in an action for infringement, he must have entered a disclaimer, prior to the commencement of the suit, as to that part of the invention which was erroneously claimed.*

A patentee desirous of obtaining a prolongation of his term, must, before the expiration of the term, pay 40 dollars into the treasury, and make written application to the commissioner, who will publish in the newspapers a notice thereof, and of the time and place when it will be considered. A board, consisting of the secretary of state, the commissioner of the patent office, and the solicitor of the treasury, will hear and decide upon the evidence produced. The patentee must furnish the board with a statement in writing, under oath, of the ascertained value of the invention, and of his receipts and expenditure, sufficiently in detail to exhibit a true and faithful account of loss and profit accruing to him from the invention. Should it appear to the board that the patentee, without neglect or fault on his part, has failed to obtain from the use and sale of his invention, a reasonable remuneration for the time, ingenuity, and expense bestowed upon the same and its introduction into use, it will be the commissioner's duty to extend the patent for seven years, by making a certificate thereon to that effect. The benefit of the extension will be enjoyed by assignees and grantees of the right to use the thing patented, as far as their interest extends.

ON THE OCCASIONAL OSCILLATIONS OF THE STEAM-PRESSURE INDICATOR.

II.

Let us now consider the circumstances attending the application of the instrument—suppose to a condensing engine. When the eduction valve closes, the piston of the instrument is at its lowest position, in consequence of the partial vacuum in that end of the cylinder with which the instrument communicates. But usually the eduction ceases when the piston is still at some distance from the end of its stroke, and in consequence the vacuum is gradually destroyed by the compression of the confined vapour, and the piston gradually and calmly rises towards its mean position—at which the pressures on both sides of it are equal, and the tension of the spring is zero. Supposing that it has arrived at this position by the time the piston of the engine has come to the end of its stroke, and the induction valve is beginning to open gradually, the piston will continue to ascend in the same steady manner, and the pencil will transfer to the paper a fair and indubitable expression of the relation of the pressures; the diagram will be of the ordinary character, and will present no marked undulations.

But let us suppose, that instead of the eduction ceasing some time before the stroke of the piston is completed, it is continued up to the end of the stroke, (as in the engine from which the diagram copied at the beginning of this article was taken,) and that the induction happens also to begin when the engine is on the centre; then, in place of the slow and steady rise of the piston of the indicator we had in the former case, it will bound upwards under the excess of the combined pressures of the inflowing steam and the tension of its spring over the resisting pressure of the atmosphere. Referring again to our diagram, we observe that the tension of the spring is then equal to a pressure of 13 lbs. on the square inch, and that the pressure of the steam issuing into the cylinder is at least 20 lbs. above the vacuum line: the piston of the instrument must, therefore, have been subjected almost instantaneously to an actual unbalanced pressure of $4\frac{1}{2}$ lbs.—its area being $\frac{1}{4}$ th of a square inch, and

assuming the atmospheric pressure at the time the diagram was taken to have been 15 lbs.

This is an ordinary case, but more complex, containing more conditions than it is desirable or necessary to include in a first example. We therefore reserve it for after consideration, and begin, instead, with one more simple—the simplest form, indeed, which the problem assumes, namely, that of a ball of known weight attached to a spring, *s*, of known strength, suspended from a convenient point of support. We may further suppose, for simplicity, that when the ball is in the position, *A*, the spring is not stretched—that it is then in its normal state, or that its tension is then 0; that the weight of the ball hanging freely by it (at rest) stretches it so much that the ball occupies the position, *c*; that consequently, in this position, the tension of the spring and the weight of the ball are in equilibrium, and may be represented by the horizontal line, *c, d*, containing as many linear units as there are units of weight contained in each of the pressures.

Fig. 2.

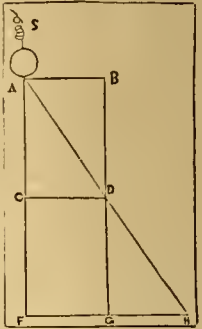

Now, let us suppose that when the ball is at rest in its first position at *A*, it is instantaneously abandoned to gravity; it descends against the uniformly increasing resistance of the spring, and by the time it has arrived at *c*, it will have developed a quantity of motive work proportional to the area of the rectangle, *A, B, A, C*. But the resisting work developed by the spring in the same interval of time is only half as much, namely, the quantity represented by the triangle, *A, c, d*. Now this excess of motive work cannot have been lost, but is accumulated somewhere—in the moving matter—by virtue of the principle of mechanical equivalence found to prevail under all circumstances of a like nature. We, therefore, find no difficulty in concluding that the portion of motive pressure not expended in overcoming the resisting pressure of the spring, must have been employed in generating velocity of the ball itself (and of the spring to which it is attached, but which meantime we may neglect). The ball will, therefore, not come to rest at *c*, but will proceed onwards till this accumulated work has been expended in stretching the spring to such an extent, that the total resisting work is equal to the total motive work. This state of equilibrium will be established when the areas generated by the moving pressures are equal—namely, when the triangular area, *A, F, H*, is equal to the rectangular area, *A, B, A, F*; and this condition will be fulfilled when $A, C = C, F$, and $F, H = 2, C, D$.

From this, then, it appears that the weight which is sufficient to stretch the spring by the quantity, *A, c*, (which for simplicity we shall denote by *l*), being applied at once, or instantaneously, when that amount of elongation has been produced, exactly *twice* as much work will have been done by the ball as is expended upon the elasticity of the spring; and that work being accumulated in the ball and in the matter of the spring, the ball will continue to move onwards, and elongate the spring yet as much more—namely, until the tension of the spring has become equal to *twice* the motive pressure (of the ball), and the whole elongation is $A, F = 2l$, or *twice* the amount of elongation which the weight is capable of permanently maintaining. In this extreme position of the ball, its weight is equal only to half the reacting pressure of the spring; it cannot, therefore, descend further, for all the excess of motive work accumulated in it during its descent to *c*—namely, the portion represented by the triangle, *A, B, d*—has been expended in overcoming the increased resistance it encounters in falling from *c* to *F*. In this space, the amount of resisting work is exactly as much in excess of the motive work as it was deficient in the first half of the descent—namely, the quantity represented by the triangle, *d, e, H*.

But if the ball cannot descend below the position *F*, neither can it remain at rest in that position; for it is there opposed to a reacting pressure *twice* as great as its weight. It, therefore, immediately begins to ascend. Nor will it come to rest at the position *c*; for when the spring has, in consequence of its elastic reaction, shortened itself that much, it will have developed an amount of motive work greater by half than the work which would be sufficient merely to elevate the ball through the space, $F, C = l$; it will, therefore, continue still further to contract its length, until this excess of work is expended; that is, until, as before, the quantities of motive and resisting work become equal. And this condition will be fulfilled when the ball has arrived at its first position, *A*, and not sooner.

It is, then, clear that the ball would thus continue to oscillate for ever between the positions *A* and *F*, equally on each side of the position *c*, if it could be freed of the external influence of the atmosphere, and if the elasticity of the spring were perfect within the limits assigned—for all that is true of any single oscillation between those limits, is equally

* This is much more liberal towards patentees than the rule in our law. In England, if part is bad the whole is rendered bad, until the vicious part is excised by disclaimer.

true of every other in the same direction, and therefore of any number of oscillations in succession. It would also be easy to show what the velocity of the ball is at any instant; but this part of the problem is not essentially necessary for our immediate purpose, and may, therefore, be deferred, merely remarking, in the meantime, that the velocity will be a maximum at the instant the ball is passing through the position *c*, in either direction; for at that instant the resisting pressure is equal to the motive pressure, and the ball ceases to acquire velocity, and begins to be retarded. It might also be shown that the velocity of the ball, when greatest, is equal to that which it would acquire by falling freely through a height = $\frac{1}{2}l$; that is, through a height equal to half the linear extension of the spring maintained by the ball in a state of rest. We are also able, in the same way, to calculate the number of oscillations which the ball will make in a given time. These are performed isochronously—the moving pressure upon the ball varies directly as its distance at any time from the middle position *a*, as in the case of the ordinary pendulum; hence the time of each complete oscillation will be expressed by the formula,

$$\frac{2}{3.1416} \sqrt{gl} = \frac{1}{1.5708} \sqrt{gl};$$

and the number of oscillations performed in a second, by the formula,

$$\frac{1}{2 \times 3.1416} \sqrt{\frac{g}{l}} = \frac{1}{6.2832} \sqrt{\frac{g}{l}};$$

in which *g* represents the velocity which gravity produces in a falling body in a second of time, and *l*, as before intimated, is the range of the oscillation, or the space which the ball describes on each side of its middle position, *c*.

This example illustrates the action of the indicator when it so happens that the steam is admitted upon it suddenly, and the pencil is at zero; the spring is then without tension, and the steam column projected upon the piston performs the same part as the ball performs in the foregoing illustration. It is not, however, the entire weight of the steam column which is to be considered, but only its excess over the weight of a column of atmosphere, of equal base, sustained on the other side of the piston. If the weight of the steam column considerably preponderates, and the admission is sudden, it is then clear there will of necessity be more or less oscillatory motion of the piston of the instrument (and therefore of the pencil) produced. The oscillations will in no actual case be so great as would be produced under such a set of conditions as are here presumed, for the full pressure of the steam is not applied instantaneously, and the instrument is subject to frictions of different kinds. If the steam pressure accumulates so gradually that it never exceeds at any instant the resisting pressure of the spring, then there will of course be no oscillation of the pencil produced; if it accumulates faster, the pencil will rise beyond the height due to the statical pressure, and oscillate about that position.

Fig. 3.

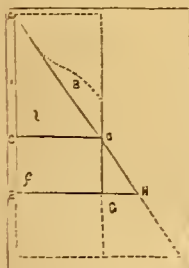

Thus, supposing *A*, as before, to denote the normal position of the piston of the instrument, and that the steam-pressure accumulates gradually, but more rapidly than the tension of the spring, as indicated by the curve, *A, K, L*, falling without the line of uniform increase of the tension of the spring; then the excess of motive work between *A* and *c* (at which the opposing pressures are equal) will be represented by the triangular space included between the line, *A, n*, and the curve, *A, B, D*; and consequently the piston will proceed beyond the position *c*, and come to rest at *F*, when the excess of resisting work developed by the spring on the piston (represented by the triangle, *D, G, n*), below *c*, has become equal to the excess of motive work

developed upon it by the steam above that position. But arrived at the position *F*, the pressure exercised by the spring upon the piston of the instrument will exceed that of the steam on the other side of it by the quantity, *G, n*; it will therefore return, pass through the position *c*, and come to rest at *i*, as much above *c* as *F* is below it, and where the quantities of motive and resisting work developed on the piston are equal. Practically, of course, the range of oscillation will be considerably less, as between *f* and *i*, on account of the friction of the instrument.

It rarely happens, when the steam-pressure is admitted upon the instrument, that the pencil is at zero; more commonly the spring has a certain tension on one side or other. In the high-pressure engine, and in condensing engines having a large amount of cushioning, the spring may, at the instant the new steam begins to be admitted, stand at the position *i*, in the preceding figure. It is easy, however, to perceive, that in such cases exactly the same explanation applies, and need not be

repeated. On the contrary, the tension of the spring may be negative—as in the case of the diagram at the beginning of this article. It then happens that the pressure of the spring and that of the steam act at first in the same direction, until the spring arrives at its zero; from that instant the two pressures begin to be opposed, and to act in contrary directions, as in the cases discussed. It is then plain, from what has already been advanced, that the quantity of work developed by the concurrent pressure of the spring must be added to that of the steam-pressure in the first part of the motion, and will tend to enlarge the amplitude of the oscillations by as much as the piston is primarily beyond the zero of the spring. Constructing the diagram: this quantity is represented by $\Delta \kappa$, and the inverse tension of the spring by κL , so that the work developed by the spring on the piston of the instrument, in the direction of its motion, is represented by the triangle, κ, L, A . And supposing that the whole steam-pressure represented by $\kappa B'$ could be thrown instantaneously upon the piston, then the excess of motive work, up to the position *c*, (at which the reacting pressure of the spring is equal to the steam-pressure,) would be represented by the triangle *D, L, B'*, and the whole resisting work by the triangle, *A, C, n*. Under these circumstances, therefore, the piston would pass *c* with a velocity equal to that which a heavy body would acquire in falling through half the height of *C, K*, and come to rest at *F'*, when the excess of resisting work, represented by the triangle, *n, C', n'*, had become equal to the excess of motive work developed upon it in the first half of its travel.

Fig. 4.

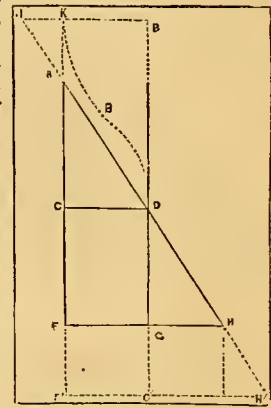

Such a range as this will not take place in practice, because the entire weight of the steam-pressure cannot be made to act upon the piston instantaneously. The steam-pressure, in the very worst cases, accumulates gradually—somewhat in the manner represented by the curve, *K, B, D*, referred to κC as base—and consequently the piston will proceed beyond *c* only as far as *F*, when the excess of resisting work, *n, C, n*, beyond *c* is become equal to the excess of motive work, *n, L, K, n*, above it. Nor will the piston return to κ when its motion is reversed, but will come to rest at a distance, *r*, from *c*, equal to the distance of *F* from that point on the other side, so that $C I = C F$.—It is scarcely necessary to repeat, that by steam-pressure is here to be understood pressure in excess of that of the atmosphere.

That there may be no oscillatory movement of the pencil in cases of this kind, it is not sufficient that the steam-pressure should accumulate only as fast as the tension of the spring, or that the curve, *K, B, n*, should coincide with the lines, κA and $A D$; for there would still remain the excess of motive work done by the spring upon the piston in the space κA as excess, and therefore the piston of the instrument would be carried beyond its statical position, *c*, proportionally far. That there may be no oscillation of the piston, or that it may rest at *c*, the curve representing the steam-pressure must fall within the triangle, *A, C, D*, and cut off a portion of it equal to the area of the small triangle, *A, L, K*, in order that the whole motive work may be equal in amount to the whole resisting work done upon the piston up to its statical limit.

There yet remains the case of the problem, which Mr. Parkes regarded as the *experimentum crucis* of his hypothesis. Mr. Parkes fixed a clamp on the spindle of the piston of the indicator, so as to prevent the piston descending below the pressure due to the steam, and yet he found that, when the steam was admitted, the piston was projected upwards considerably above that limit. From what precedes, it is evident that this was no more than what was to be expected in the case of an engine, of which the valve was so set, that the ordinary diagram exhibited an oscillatory movement of the pencil; that is, when the piston of the instrument remained free. The initial saltation of the pencil would, indeed, be somewhat increased by Mr. Parkes' arrangement. But, in general, supposing the piston to be fixed at its statical position, *c*, (in any of the preceding figures,) with a partial vacuum under it, and that a column of steam of that pressure—more correctly of that weight—is suddenly admitted upon it, it will affect the piston exactly as a heavy body falling through a space equal to that between the point of admission and the position of the piston under a retarding influence, more or less considerably, according to the degree of vacuum therein existing at the instant of admission. Thus, supposing the pressure of the steam in the valve-casing to be 30 lbs. on the square inch, that of the atmosphere at the time 15 lbs., and the pressure of

vapour within the cylinder 10 lbs., then the piston of the indicator (supposing it to have a square inch of area) would be subjected to the action of a moving pressure of a column of steam of 5 lbs. (neglecting all frictions, and all expansion of the steam in entering the cylinder) falling through a height corresponding to the extent of vacuous space in the cylinder. It will, therefore, have accumulated an amount of work represented by $5h$, and this work being suddenly communicated to the piston of the instrument (at rest), must, of course, cause it to recede until it is taken up by the spring.

In practice, the steam enters the cylinder gradually, and the pressure increases in the same way, so that the work accumulated is usually much less than it is according to this mode of considering the question; but the principle is the same, whether the quantity of momentum acquired by the steam be great or small: it will always cause the piston to recede from its stational position as certainly as if the (surplus) weight of the steam column were concentrated in a ball of metal, and allowed to fall upon it from an equivalent height.

There are several other circumstances connected with this problem, some of which possess considerable interest to the analyst, but our space is more than exhausted. What has been said is sufficient to explain all the cases of oscillation which occur by sudden changes of pressure, whether of the indicator or of gauge columns of mercury, and we must be content with this much for the present.

W. M. B.

JAMES' WEIGHING MACHINES AND WEIGHING CRANES.

By MESSRS. JOHN JAMES & Co., Whitechapel, London.

(Illustrated by Plate 124.)

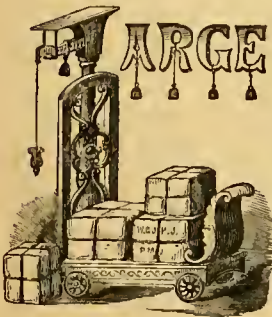

Platform Weighing Machines belong to a class of apparatus which especially demands a judicious combination of strength, carefully arranged details, and extreme accuracy and delicacy of working action. Great weights and bulky masses have to be tested by them, and the necessities of commercial transactions imperatively demand that even machines of the longest weighing ranges should yield accurate indications in the speediest possible manner. The firm whose lately patented improvements in such mechanism we now introduce to the readers of the *Practical Mechanic's*

Journal, has long stood in deservedly high repute for works of this kind; and we therefore have little hesitation in presenting their last modifications, in illustration of what a good modern weigher really is.

Fig. 1, on our plate 124, is a transverse vertical section of Mr. James' new platform weighing machine; the pillar and bracket being turned round to a position at right angles to the proper position, so as to exhibit the details in a clearer view than would otherwise be obtainable. Fig. 2 is a vertical section, on a larger scale, of a portion of the steelyard apparatus detached; and fig. 3 is a plan of the steelyards corresponding to fig. 1. *a* is the supporting platform, which is carried by the two cast-iron girders, *b*. These girders have projecting lugs, *c*, cast on their under sides, which lugs are slightly V-grooved, and rest upon the steel-knife edges, *d*, carried by the short bent lever arms, *e*, cast on the tubular beams, *f*. These beams are fitted with steel knife-edged centres, *g*, which rest upon the V-grooved bracket supports, *h*. At *t* are somewhat similar supports, cast in one piece with the supports, *h*, and serving as rests for the ends of the girders when the machine is not in use. An arm, *j*, is cast on the under side of each of the hollow beams, near the lower extremity of which is fitted a knife-edged steel pivot, *k*. A connecting-rod, *l*, connects these two arms, the straps at its extremities being slipped over the steel centres in the lever arms, *j*. Similar arms, *m*, are cast on the upper surface of the hollow beams, and are also fitted with knife edges, *n*. At *o* are cast-iron rods, with V-grooved ends, which connect the corresponding opposite arms, *m*, by being fitted in between their respective knife-edged centres. In order to secure the girders from longitudinal jarring or displacement, they are tied by the rods, *p*, to the fixed brackets, *r*, a slight play being given to the rods to allow of the ascent and descent of the platform. The girders are retained in their proper position laterally by the transverse tie-rods, *q*. The long weighing beam, *s*, is bolted to an eye at *s*, on one of the hollow beams, and is fitted at its free end with a steel pivot, *t*, to which pivot is hooked the lower end of the long link, *u*, and the latter is similarly attached at its upper extremity to a pivot, *v*, on the end of the steelyard. The

weights and steelyards, with the mechanism for their elevation, are carried by the cast-iron pillar and bracket, *w*. The elevation of the steelyard and platform is effected by the hand-wheel, *x*, which works loosely on a stud centre in the side of the pillar. On the boss of this wheel is cast a small bevel pinion, which gears into the teeth of the bevel-wheel, *y*, keyed on to the end of the shaft, *z*. This shaft works in the fixed bearings, *a*, cast on the pillar and bracket, and is fitted at its outer end with a spur pinion, *b*, which gears with the teeth of the vertical rack, *c*. The upper end of this rack is flattened, and has a slot formed in it, through which is forced the outer end of the steelyard. Another pinion, *d*, of the same diameter, is keyed on to the shaft, *z*, and gears into the vertical rack, *e*. This rack is cast in one piece with the cap, *f*, of the pillar, and consequently, as the rack ascends, the cap, *f*, will rise with it. The cap is open on one side to admit the end of the steelyard into the interior of the pillar, and on each side of this opening is fitted a V-grooved steel bearing-piece, *g*, these pieces serving as rests for the steel pivots, *h*, forming the fulcrum of the steelyard. The periphery of the bevel-wheel, *y*, is grooved to receive a chain, *i*, and counterweight, *j*, one end of the chain being screwed to the periphery of the wheel. This counterweight balances the weight of the platform, and thus facilitates its elevation when requisite. The steelyard is composed of two bars, *kl*; the one, *k*, representing tons, and the other, *l*, indicating cwt. Both these denominations are read off by pointers or indicators attached to the respective weights on one scale, which consists of a T-shaped bar, *m*, attached at its ends to the steelyard by small stud pillars and bolts. At *n* is an indicator, attached to the end of the steelyard, to show whether the machine is in or out of gear, this being clearly indicated by the discrepancy between the height at which the indicator stands, and that of the head of the rack, *c*. The large ton weight, *o*, is fitted with a scale and small weight, *p*, on its upper surface. This weight indicates lbs. The tare weight, *q*, is shown in dotted lines, and is contained inside the body of the large ton weight. At *r* is a screw, which passes through the centre of the tare weight; so that, by turning the milled head, *s*, the tare may be adjusted to any required degree of accuracy. The large weights are made with only one running wheel; and when the weight is to be traversed along its steelyard, the loop-handle, *t*, which is secured to the upper surface of the weight, is first raised sufficiently to release the small catch beneath it from its notch, when the weight may be run on its wheel to any required notch in the steelyard. By this arrangement, the friction and wear of hanging weights is entirely obviated. In order to raise the platform from its rests, *r*, the hand-wheel, *x*, is turned by the winch-handle attached to it. This turns the pinions, *b* and *d*, and consequently elevates the cap, *f*, and outer end of the steelyard simultaneously, drawing up the free end of the weighing-beam, *s*, and raising the platform off its bearings. By the time a sufficient elevation has been obtained—which will be effected in about four revolutions of the hand-wheel—a catch in the side of the cap, *f*, has attained a sufficient height to lay hold of a pin in the side of the hand-wheel, holding it fixed in the proper position, and retaining the platform as elevated. A weight on any portion of this platform will be equally distributed over the whole surface, being transmitted through the entire platform, along the hollow beams and connecting-rods or bars, *l* and *n*, and thence to the large weighing-beam, *s*.

Another branch of the invention relates to an improved plan of standard or steelyard support. In this contrivance, the head of the standard is made to overhang the stem very considerably, so as to allow sufficient space for the suspension of large bodies, such as sacks of flour and potatoes, without coming in contact with the side of the standard. A support of this kind is of a very simple construction, and consists merely of a rectangular bar of wrought-iron to form the vertical standard, the base being made by simply bending the lower end of the bar into a circle, or any other suitable shape, large enough to form a steady bearing for the whole apparatus; the pivot from which the weight is suspended should, however, be in the same vertical line with the entire of the base of the standard.

The third portion of the improvements relates to a novel arrangement of steelyard, wherein two distinct steelyards are used for indicating two separate denominations of weights; for example, one steelyard may serve to indicate cwt., and the other qrs. and lbs. By this means, heavy steelyard weighing machines may be made to indicate small weights with greater accuracy than can be obtained by steelyards of the ordinary construction. By another arrangement, one steelyard bar may be made to answer the same purpose, by making it rather deeper than usual, and graduating both the upper and lower edge, and using a separate weight for each, so that the upper edge may indicate cwt., and the lower edge qrs. and lbs. By dividing the steelyards in this manner, greater space is afforded for the notches, and consequently, a greater number may be inserted, and therefore greater nicety of reading is obtained.

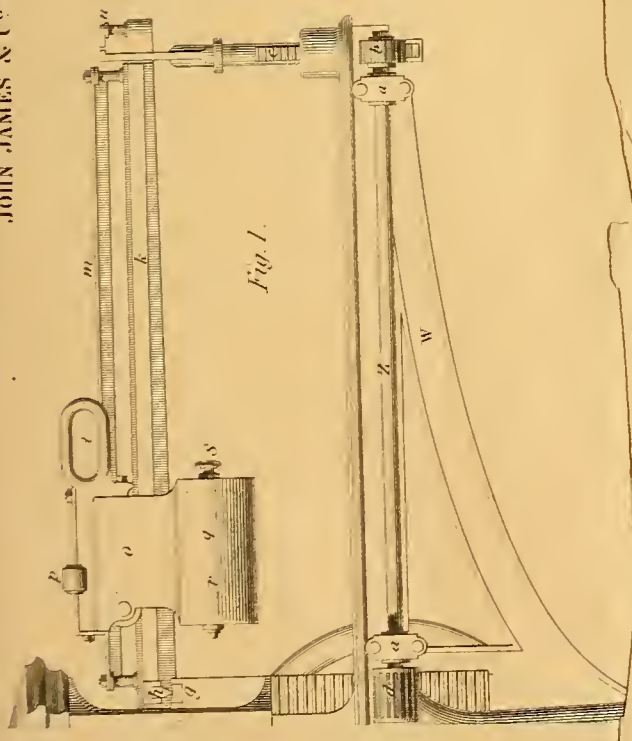
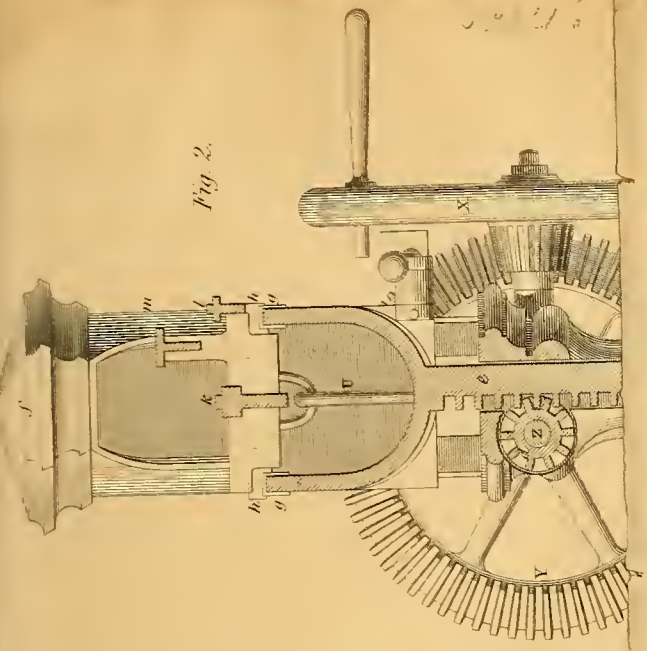

Fig. 2.





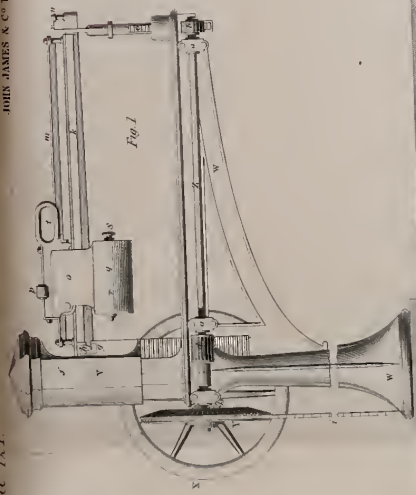

Fig. 1

Fig. 2

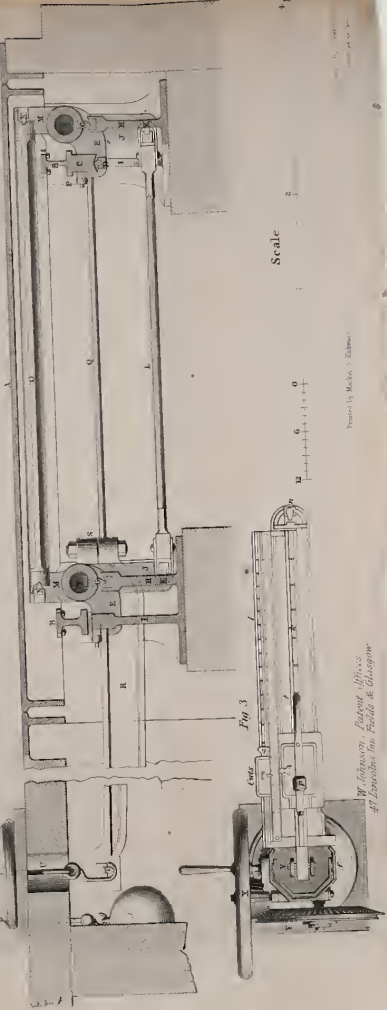
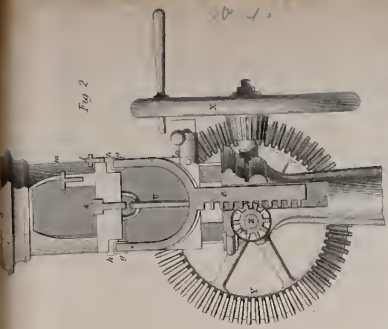

Fig. 3

Scale



W. Johnson, Patent, 1855.
47, Lincoln Inn, Fields & Glasgow

Printed by Mackay & Colburn.

MECHANIC'S LIBRARY.

Colouring, Principles of Beauty in, Svo., 15s., cloth. D. R. Hay.
 Dyeing, Manual of the Art of, 12mo., 7s. 6d., cloth. J. Napier.
 Encyclopædia Britannica, 8th edition, Volume I., Part 2, 4to., 8s., sewed.
 Euclid, Elements of, Part I., 12mo., 1s., cloth, sewed. Law.
 Euclid's Elements, Book I., with Notes, 12mo., 1s., cloth, sewed. Potts.
 Fuel, On, 12mo., 1s., cloth, sewed. Prideaux.
 Geological Observer, 2nd edition, Svo., 18s., cloth. De la Beche.
 Hydraulic Tables, Svo., 9s., cloth. J. Neville.
 Industrial Arts of 19th Century, 2 vols. imp. fol. £17. 17s. M. D. Wyatt
 Leather Work, Guide to, 12mo., 2s. 6d., cloth. Revell.
 Microscope, on the Construction of, Svo., 5s., cloth. Hannover.
 Natural Philosophy, new edition, 18mo., 2s. 6d., cloth. W. Martin.
 Optics, "Lardner's Cyclopædia," new edition, foolscap Svo., 3s. 6d. Brewster.
 Organic Chemistry, Principles of, Trans., 16s., cloth. Dr. Löwig.
 Scientific Discovery, Annual of, 1852, crown Svo., 7s. 6d. D. A. Wells.
 Science, Marvels of, 4th edition, crown Svo., 7s. 6d., cloth. S. W. Follom.
 Stereoscope, On Construction and Use of, Svo., 5s., cloth. Hannover.

RECENT PATENTS

POWER-LOOM WEFT-FORKS.

WM. STEVENSON, *Rothsay*.—*Patent dated October 15, 1852.*

The ordinary weft-fork, or protector, as commonly used for power-looms for stopping the loom action when the weft-thread breaks, is subject to very frequent breakage from the chance catching of the shuttle against it, as every loom-tackler well knows. Mr. Stevenson remedies this evil by so forming the forks, that when in danger of fracture from this cause, part of the fork may give way. To effect this, the vertical portion of the fork, or that part whereon the weft-thread acts, is hinged or jointed to the body of the fork; so that, on coming in contact with the shuttle, in case of stoppage of the latter in its transit across the loom, such piece may be thrown up upon its hinge, and thus prevent the fork from breaking. After such action, the hinged piece falls down again to its proper working position, and the joint being made with a stop on the opposite side of its centre, the motion of the piece in the other direction is prevented, and the fork's action, in connection with the working of the weft, is unimpaired.

Fig. 1. is a side elevation of one form of the improved weft-fork, as in working action. Fig. 2 is a plan corresponding. The fixed stud or holding stay, A, of the fork, is cast with a wide double eye, B, for the reception of the flat expanded end of the detent lever, C, which is retained in position by a rivet-joint pin passed through the lugs, B, of the double eye, and through the lever. The latter is thus well guided laterally, whilst the expanded portion, B, affords room for the reception of the

Fig. 1.

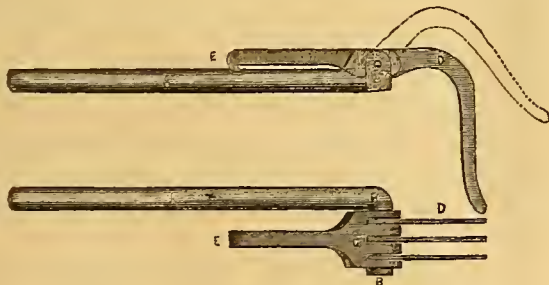

Fig. 2.

hinged prongs, D, for the actual weft action. These prongs are, as usual, three in number. They are loosely entered into three corresponding slots in the piece, C, and the single-joint pin already referred to, secures them on their centre of oscillation. The bottom of each of the recesses or slots in the piece, C, is angularly sloped, whilst the inserted end of each of the prongs is correspondingly angled, or inclined, to fit to it; the result of this arrangement is, that so long as the fork works in its regular routine of duty, its prongs hold the position assigned to them by the sharp lines of the figures; the passing weft-thread acts upon their vertical portions, so as to elevate the catch, E, of the detent lever, clear of the stop movement, at each passage; just as would occur with the ordinary fork, because the incline upon the prong acts upon the inclined bottom of its recess exactly in the same manner as would arise if the fork were a solid one. But, on the other hand, if an intercepted shuttle chances to be in the way, it simply acts upon the inside edges of the prongs, D, and elevates them, on their joint centre, to the position delineated by the dotted lines. Thus the prongs give way; and their fracture, which is inevitable with the common solid fork, is avoided. Then, so soon as the obstacle is removed, the prongs fall to their accustomed position, and their regular action goes on.

A similar effect is also obtainable by constructing the vertical or prong

portion of the fork of some elastic material, which yields when struck against the shuttle, but is stiff or rigid enough for the weft action. This is a very simple and ingenious way of getting rid of a serious objection in power-loom weaving.

SMOKELESS FURNACE.

JOHN LEE STEVENS.—*Patent dated October 1, 1852.*

This is the earlier of two patents obtained by Mr. Stevens in the same month. It relates to an arrangement of furnace to work without any moving parts whatever; whilst the latter patent, of October 27th, comprehends a rather complicated system of revolving bars. We mention this for the reason that, about three months back, the daily prints gave

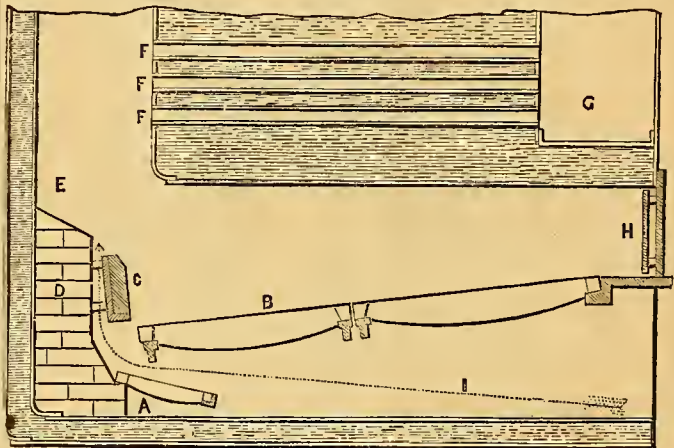

reports of a statement made by the inventor before the *City of London Commissioners*, in some measure confusing the details of the two plans. Our engraving represents a longitudinal section of the furnace actually fitted to the General Screw Steam-Shipping Company's vessel, the *Earl of Auckland*, running between London and Rotterdam. In this figure, A is the first set of furnace bars, and B the second, or hack set; C, calorific plate, faced with firebricks; D, bridge; E, furnace flue; F, hoiler tubes; G, funnel flue; H, furnace door; I, direction of the current of air.

The inventor has not interfered with the previous fastenings, so as to risk any damage to the hoiler; nor has he changed the gauge of the bars, B. The only alterations from the ordinary mode being the reduction of the thickness of the bridge, D, and the addition of the first set of bars, A, and of the calorific plate, C; thus allowing A to be supplied with fuel from B, and yielding free ingress to the current of air, I.

It will be seen, that by this arrangement the ignited coals voided upon the bars, A, constitute, with the burning fuel on the bars, B, two strata of fire, through which the air, rapidly absorbing the caloric in its passage, proceeds upwards, and becomes still more intensely heated between the calorific plate and the bridge, and is then emitted at the necessarily high temperature, where it effectually intercepts and gives continuous and complete combustion to the gaseous products of the coal; its operation being only very partially suspended by the opening of the furnace door for the requisite addition of fuel. In fact, it is a double furnace, confined strictly to the limits of, and cheaply applicable to, any description of furnace; has all the advantages of a hot-blast without the complexity of any moveable apparatus; is so contrived as uniformly to distribute and keep up the heat, as well as to increase the draught; and, whilst thoroughly curing the smoke nuisance, and preventing the usual deposit of soot in the flues, it is said that, in the case of the *Earl of Auckland*, it effects a saving of from 15 to 20 per cent. in the consumption of fuel; and still greater reductions in furnaces upon land—varying, indeed, from 20 to 26 per cent.

Hitherto, however, with the exception of one furnace at Northampton, in which the fuel is largely economised, the invention has been modified to meet the peculiar requirements of furnaces long in use, and generally of defective construction. And if such satisfactory results follow its application to the large number already so improved in London and the provinces, it is only reasonable to assume that more abundant advantages will be apparent when Mr. Lee Stevens has fairer play given to his invention by its use in new furnaces. At all events, the simplicity and universal applicability of his plan—its economy of cost, and the enormous savings consequent upon its use—with the unquestionable facts in his favour, that are verified by the most respectable and disinterested testimony—must insure to him ample remuneration for the ingenuity evinced in his invention.

ARTIFICIAL ILLUMINATION AND HEATING.

A. M. DIX, *Salford*.—*Enrolled Feb. 7, 1853.*

Mr. Dix's invention relates to the so arranging, illuminating, and heating apparatus, that the gas or other combustible shall be consumed, and the necessary oxygen supplied thereto for the support of combustion, quite irrespective of the atmosphere of the apartment where the apparatus is placed. To this end the light is contained in a close

heating apartments, the closed chamber in which the combustion is carried on may be either transparent or not, as preferred, and it may be either plain or ornamental, care being taken that the ingress of fresh air for combustion, and the egress of the foul or exhausted air from the vessel, shall be duly proportioned; and it is to be here remarked, that for heating purposes it is preferable for the fresh air to be conducted directly to the gas, the foul air circulating in the vessel, and allowing the heat to radiate into the apartment, and in cases where a downward draught is required for the consumed air.

Our engraving represents the invention as applied to an ordinary pendant gas lamp, the figure being a vertical section of the upper and lower portions of the lamp, one-fourth the real size. A is the closed vessel, or chamber, in which the combustion takes place. It is formed of glass or other transparent substance, and ornamented by cutting. B is the pipe for supplying air to this chamber. This pipe terminates at its upper end above the ceiling, C, of the apartment, in a closed box, D, which communicates, by means of a pipe or tube, E, with the atmosphere above the roof, or with the atmosphere of the roof or loft above. F is the pipe for the exit of the hot air, communicating also with the external atmosphere by means of the pipe, G. It is advisable that these two tubes, A and G, should terminate at the same place—the still atmosphere of a loft, or other spare

room, being preferred—and should open in the same direction, in order that the pressure of the atmosphere may at all times be equal upon both of them. The tube, F, is encased in a third tube, H, the space between the two tubes, F and H, being filled with water. At I is a small tube for conveying cold water to the lower part of the said space, and K is a similar tube for conveying the water (as it becomes heated) from the upper part of this space. These two tubes, I and K, terminate in a tank, so that a constant circulation going on, the water in the space between the two tubes is kept cool, this water being employed as a non-conductor—first, to maintain a dissimilar temperature between the fresh and foul air; and, secondly, to preclude the possibility of any danger to the building from fire. The foul or hot air tube may be similarly encased throughout. At L is the pipe for supplying the gas, and to the lower end of this is attached the burner, M. The burner is surmounted by a glass chimney, N, which is connected to the exit-pipe by a short sliding tube, O, fitting loosely into the lower end of the pipe, F. The lower end of the tube, O, is turned upwards, in order that any vapour that may condense upon the inner surface of the tube, and run down between the two tubes, F and O, may lodge there, and be again evaporated, instead of passing into the chamber, A. The stop-cock, P, for admitting or shutting off the gas, may either be placed in the chamber, A, or in any other convenient situation. The tube, H, is connected to the tube, N, and thus supported by means of the screws, Q. The glass chamber is held in a metal ring, R, by means of screws, S, and this ring is connected to, or disconnected from, the lower end of the tube, N, by means of a bayonet joint. The pipes, E and G, are furnished with throttle valves, or dampers, T, for regulating the draught; and the pipe, G, is depressed at G', and furnished with a small pipe, U, for conveying any condensed vapour that may lodge therein.

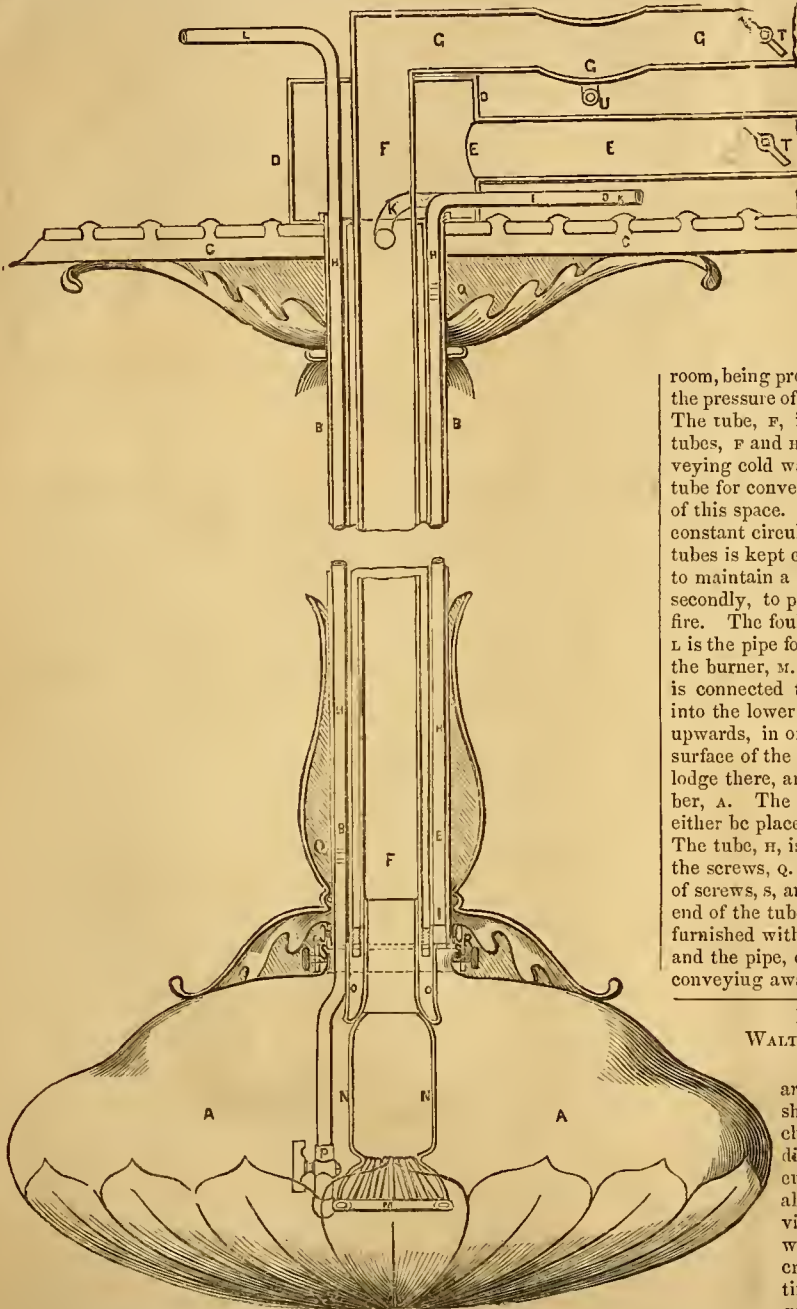

METAL SHEARING MACHINE.

WALTER WILLIAMS, *Albion Iron Works, West Bromwich.*

Mr. Williams' arrangement of shearing machine acts with a direct rectilinear cut. It is suitable for the heaviest class of work, and is creditably distinguished as a good combination

Fig. 1.

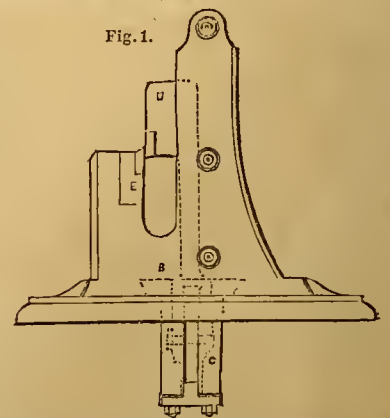

vessel, having tubes for the admission of oxygen, and the conveyance away of the products of combustion, so that the vitiated air does not mingle with or contaminate the surrounding atmosphere. The same contrivance also prevents injury to the steadiness of the light, from the opening and closing of doors, or other disturbances in the atmosphere. It may also be applied to the lighting of mines, or may be used under water, or in any other situation where an exposed light might be impracticable or dangerous, as the light can be sustained independent of the nature of the immediately surrounding medium. In

tion of strength and simplicity. Fig. 1 of our engravings is a side elevation of the machine; fig. 2 is a plan, and fig. 3 an end view. The cast-iron bed plate, A, forms the foundation of the machine, carrying the duplex guide standard, or "houseings," n, and the carriage, c. The moveable shear-blade, D, works in

vertical dovetail slides in the face of one of the standards; whilst the fixed blade, E, is secured to the face of the opposite standards by corresponding reverse dovetails.

The actuating slide, F, works through the carriages, C, being jointed at e to a connecting-rod passing to the pin of a constantly revolving crank. The two standards, H, are attached to the shear, D, and pass through the bed plate, to embrace the upper edge of the slide, F. To this slide they are connected by transverse pins and anti-friction rollers working in the curved slots, I, in the slide. These curved slots are so ar-

Fig. 2.—148th.

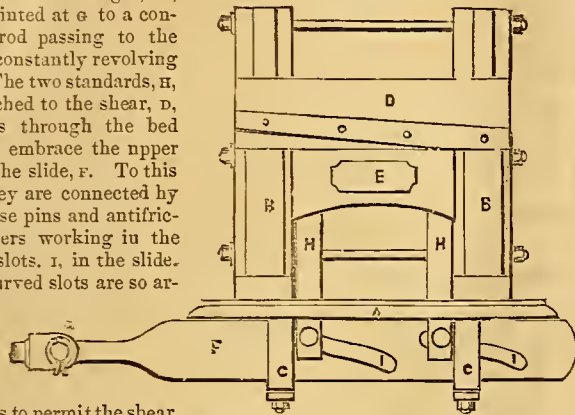

ranged as to permit the shear, D, to remain open and stationary, the upper portions of the slots being straight and horizontal for this purpose. The extent of this neutral action is adjustable to suit the time

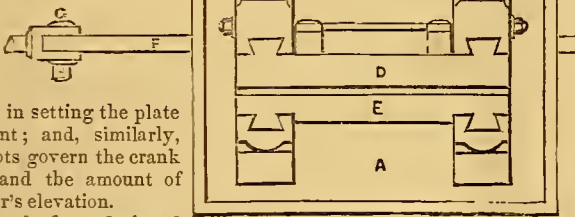

required in setting the plate to be cut; and, similarly, these slots govern the crank throw, and the amount of the shear's elevation.

The standards are designed to allow of shearing plates of any length, as a clear open traverse is effectually secured for the passing plate during the shearing action. This action is pretty obvious, on considering the effect of the crank's revolution upon the slide, F. As the latter thus reciprocates, the curved portions of the slots, I, act upon their anti-friction rollers, and force the moveable shear up and down, giving a powerful vertical cutting action against the stationary blade.

CINDER BASKET.

MATTHIAS WALKER, *Ironmonger, Horsham.*—*Patent dated Oct. 1, 1852.*

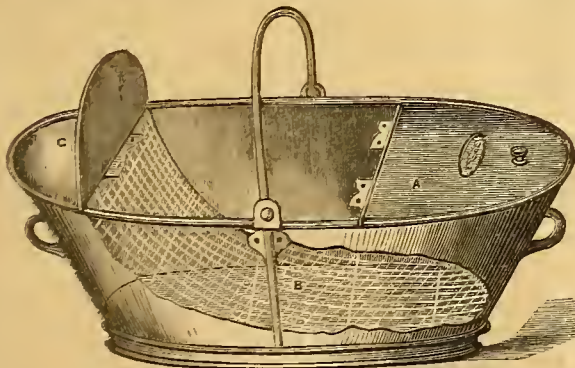

Our engraving exhibits this useful little invention with its side and cover partially broken away, to show the internal arrangement. The cinders and ashes to be separated are shovelled into it by the large end door, A, and they thus fall on the curved incline grating, B. Then, by shaking the basket, the ashes fall through the grating, and may be emptied by the small end door, C, whilst the cinders remain in the basket for use. The basket presents a very neat exterior; and, as it is all covered in, no dust can rise during the process of sifting. Besides, it

effects considerable economy in the cinders. Mr. Walker has also patented an important contrivance applicable to barrels and other fluid-containing vessels. This arrangement, which he terms a "hydrostatic vessel," consists in encircling the vessel with an outer case, filled with a cooling fluid, so that the actual contents of the vessel are well defended from atmospheric influences, and are kept fresh, cool, and at a uniform temperature.

CRAYON DAGUERREOTYPES.

J. E. MAYALL, *London.*—*Patent dated Jan. 25, 1853.*

This invention relates to an ingenious mechanical arrangement for carrying out Mr. Mayall's beautiful "crayon" process of stopping out, or softening off, portions of photographic pictures. Our engraving repre-



sents a front view of the apparatus, complete. It consists of a slowly revolving disc, A, arranged on a support somewhat like a fire-screen, and having a central opening in the form of a large star. This disc is carried between the forks, B, of a frame-piece, the stem, C, of which is adjustable as to height in the pedestal, D. To keep the disc in motion, an arrangement of clock work is attached to the framing, the actuating spring being contained in a box, E, driving a spur-wheel in gear with a pinion, F, on the spindle of the fly, G. The screw for setting the disc up or down is at H.

This apparatus is interposed between the object, or sitter, and the camera; and the central portion of the star is made large enough to admit the rays from that part of the object which is to be shown in strong light, whilst the rays from those parts which are to be gradually shaded off to a dark background, are partially intercepted by the points of the star. In this way, the intensity of the light is gradually destroyed, and the softened-off "crayon" effect is produced. The apparatus is applicable to every description of camera, and by placing it nearer to, or further from the lens, any portions of the image may be so softened off.

MOTIVE POWER AND METERS.

T. KENNEDY, *Kilmarnock*.—*Enrolled October 4, 1852.*

Mr. Kennedy, who has long been favourably known—as well for his connection with improvements in fire-arms as in gas and water-meters—has here gained a further step in the latter branch of invention. Fig. 1 of our sketches is a front elevation of his combined water-power apparatus and meter, the front plate of the cover over the external mechanism being removed.

Fig. 1.

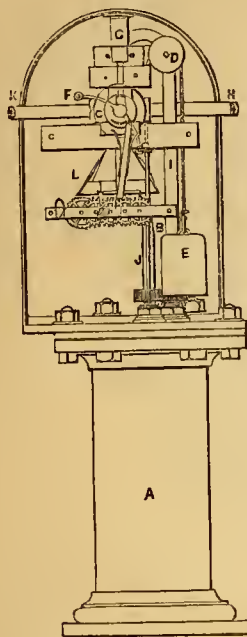

The main fluid-cylinder, A, into which the water is passed, is set vertically on a suitable base, its open upper end being covered in by a flange or base plate, in which is the stuffing-box for the rod, B, of a duplex-cupped piston to pass through from the interior of the cylinder. The projecting end of this piston-rod is connected to a cord wound upon the pulley, C, above, whilst a similar cord, wound the reverse way upon this pulley, is passed up and over a guide-pulley, D, a weight, E, being suspended to the free end of this cord. The spindle of the cord-pulley, C, is supported in suitable bearings in the containing-case, and its axis coincides with the axial line of a four-way cock, the plug or key of which has upon it a pair of lever-arms, F, each fitted with angular terminal pieces, for the weighted tumbler, G, to fall against in either direction. The fluid supply is derived from the pipe, N, terminating in the shell of the four-way cock, from the two opposite ports of which, the pipes, I, J, pass down to the upper and lower ends of the cylinder, A, respectively. The fourth pipe, K, opposite to the ingress-pipe, is the discharge passage. As delineated in the figure, the piston is supposed to have arrived nearly at the top of its stroke, water being in the act of flowing into the cylinder beneath the piston to force the latter up, whilst the previous supply is passing off from above the piston through the discharge-pipe. Then, as the piston rises further up, the consequent revolution of the cord-pulley carries round a catch-arm, and

when it falls over to the other side, and, in falling, strikes upon the elevated arm, F, of the four-way cock-plug, thus reversing the water-ways, and allowing the water to pass off from the lower end of the cylinder, and a fresh supply to flow in above the piston. The sudden blow of the tumbler is taken up by the weight falling upon the alternate ends of the traversing-piece, L, slung at each end by straps or flexible connections. When the piston arrives again at its bottom position, the same action takes place in a reverse direction, and the tumbler falls the other way, to bring the valve to the position first pointed out. Hence a continuous reciprocatory action is produced, and the power derivable from the water's pressure may be taken off the apparatus in any convenient way, as by the spindle of the cord-pulley, the rapidity of the change at the end of each stroke being such as to obviate serious objections as to intermittent motion. The quantity of fluid discharged from the cylinder at each movement being known, the apparatus becomes an indicating meter by attaching a train of index-wheels and dial. Such index is, in this example, actuated by a disc-piece on the shaft of the cord-pulley, this disc having a cam-piece, which, in coming round, presses against the upper end of a lever set on a fixed centre, and connected by detent catches with the ratchet-wheel of the train. Thus the train moves the required amount at each stroke of the piston, and the measurement is read off at the dial front. By another modification, the piston-rod terminates in a toothed rack, in gear with a toothed pinion, instead of the cord-and-pulley arrangement, and the blow of the falling tumbler is taken up by a frictional-traversing buffer.

Fig. 2 is a front elevation of Mr. Kennedy's gas-meter. The tank, A, is fitted up with a pair of chambers, B, B', so as to form a species of duplex gasometer or gas-holder, the joint being of the usual "cup and dip" form, as shown at the dotted portions, C. The two chambers are connected and hung together by the cord or chain, D, passing over the bearing pulleys, E, F, so that their motion is simultaneous in reverse directions. The gas supply-pipe is at G, opening into the lower section, H, of the valve-chamber, and in the position delineated in the drawings the gas is flowing from this chamber through the open valve, I, and down the pipe, J, which passes up into the measuring chamber, K. The gaseous pressure so produced then gradually elevates the chamber, B, and at the same time the opposite chamber, B', descends correspondingly—its supply of gas due to the previous movement passing off through the valve, L, in the upper section, M, of the valve-chamber, by means of the pipe, N, opening into the chamber, B'. This discharged gas finally passes off from the upper section of the chamber by the pipe, O. This goes on until the arrival of the chamber, B, at the top of its rise—the other one, B', being then at the bottom of its traverse; and the valves are then reversed by the action of the pulley, P. The spindle, Q, of this pulley carries a toothed pinion, R, gearing with a segmental toothed rack or wheel, S, set on a fixed centre, T, and carrying a crank-arm, U, working between the prongs of the fork, V, fast on the upper tumbler tube, W. This tube oscillates on a fixed centre, X, and contains a small quantity of mercury, so as to form a tumbler of quick action, by reason of the rapid flow of the heavy mercury from one end to the other, on the slightest deviation of the tube from the horizontal line. Directly beneath this upper tumbler is a similar tumbler, Y, oscillating on the centre, Z, and linked at R to a connecting-piece passing down into the valve-chamber through a simple hydraulic joint, A. The lower end of the connecting-piece is hinged at a, to a double lever oscillating on the centre, b, and connected at each end to a duplex valve arrangement, so contrived that there is always a closed and an open valve in each section of the chamber, the two open valves in the present case being I, K, and the closed ones, C, D. When in tracing the action of the apparatus as already commenced, it is to be understood that the adjustment is such, that when the chamber, B, is at the top of its rise, the revolution of the arm, S, on the segmental wheel, Q, acting on one of the prongs of the fork, V, causes the upper tumbler, W, to fall over to the other side of its horizontal line. The end, E, of the tumbler then falls sharply upon the piece, F, on the lower tumbler, and thus that end of the lower tumbler descends also, and its other end then draws up the valve-link, and reverses the entire set of four valves; so that gas now enters the chamber, B', through the valve, C, for a second measurement of that amount, whilst the gas already in the chamber, B, flows off through the valve, D. In this way a continuous flow and measurement is kept up with great uniformity—the registration of the amount of gas passed through the meter being effected by connecting a train of wheels and an index to any convenient movement of the apparatus, as to the segmental-wheel action of the tumblers. When fitted up for use, the whole of the mechanism is covered over by an upper casing, so that the apparatus presents the appearance of a simple rectangular case.

Fig. 3 is a vertical section of another modification of meter, wherein a duplex-measuring action is kept up by still simpler means. This ap-

Fig. 2.

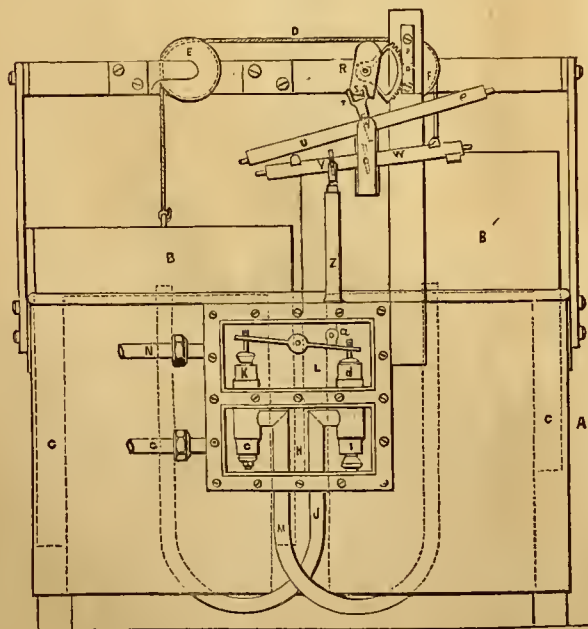

this presses laterally upon the lever-arm of the tumbler, O, which works loosely upon its spindle. In this way, as the piston rises, the tumbler is gradually carried round until it arrives at the vertical centre-line,

When fitted up for use, the whole of the mechanism is covered over by an upper casing, so that the apparatus presents the appearance of a simple rectangular case.

paratus consists of an open tank, A, in which is fitted the long inverted chamber, B, the whole forming a closed receiver, in which a quantity of water is placed. In this receiver is also an open inverted moveable chamber, C, having a central tube, D, passing through it; this tube being open at its upper end, E, but closed and perforated with a few small apertures only at its lower extremity, where also is attached the end of a slight spindle. This tubular arrangement forms a simple hydraulic joint and means of connection of the working chambers. The spindle projects above the top of the chamber, C, and works up through a fixed open-ended tube, G, fast at its upper end in the top of the case, B, which tube, the open tube, D, in the case, C, also surrounds and works over. The chamber, C, is the essential apparatus of measurement, and its spindle is connected to a cord or chain, H, the end of which is passed over guide-pulleys, and has a counterweight hung to it; this cord answering also as a means of working the index apparatus. The gas enters by the pipe, K, which opens into the hollow of the chamber C, above the interior fluid level. The discharge takes place through the pipe, L, on the top of the case or chamber, B. This meter is fitted with a valvular apparatus, like that already described in reference to fig. 2. As the gas passes in by the pipe, K, it fills the chamber, C, which necessarily rises to the top of its travel. At this stage the valvular passages are reversed, and the pipe, L, now becomes the supply-pipe, whilst the discharge takes place through the lower pipe, K. In this way the quantity of gas measured by the content of the chamber, C, is discharged therefrom by the descent of the chamber, and, at the same instant of change, a fresh supply of gas enters the upper part of the case, N; so that, when the chamber, B, has reached the bottom of its traverse, another measure of gas will have been determined by the space between the top of the chamber, C, and the case, B. The valves are again reversed at the bottom of this stroke; and thus goes on a constant succession of fillings and emptyings of the chamber, C, and the upper part of the case, B, these measurements being registered and indicated in any convenient way, by an index worked from the cord, H, or other moving detail.

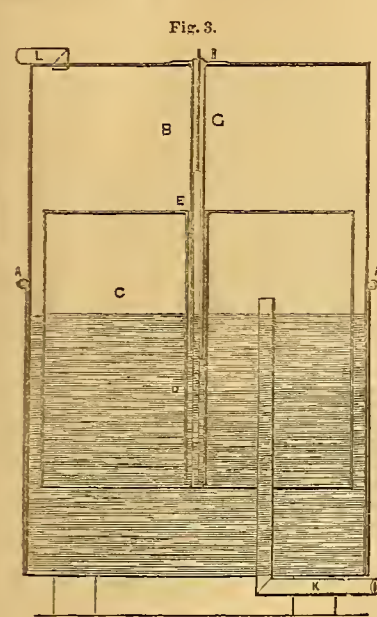

tents for hot climates. Fig. 1 is an external view of one of these tents, complete; fig. 2 is a vertical section, corresponding; fig. 3 is an enlarged view of the ventilating apparatus, detached; and fig. 4 is a corresponding section. The upper portion of the tent is made of network, or other permeable fabric, so that air may pass freely through; whilst a cover is adapted for closing up such open passage as required—a head being fitted to throw off rain, and yet retain the open work for ventilation. The section illustrates the double tent, each being fitted with means of ventilation. Hence, as there is a clear space between the two for a stratum of air, and a free outlet by the ventilating apparatus, the inner tent, or division, is screened from the external heat. In single tents, when the upper part of the tent is made of network, a stiff conical cap is fixed on the tent-post, so as to cover the opening; this cone being capable of shutting down on the tent at pleasure. But, for double tents, the arrangement in figs. 3 and 4 is preferred—the cone being supported on the top of the tent-post by inclined standards; and to the upper part of the cone is attached a pipe,

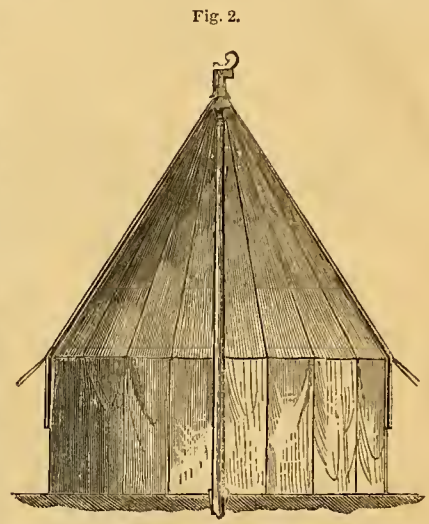
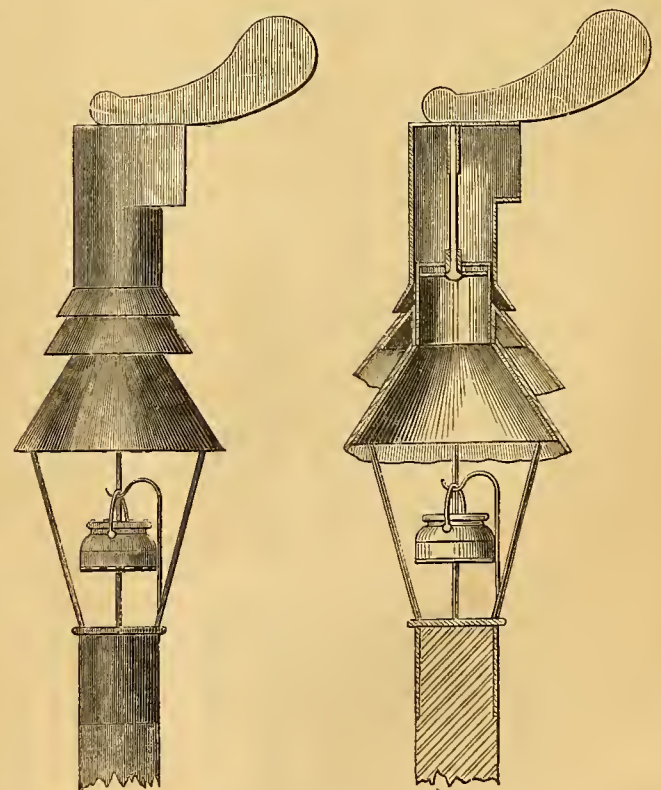

Fig. 2.

Fig. 3. An enlarged view of the ventilating apparatus shown in Fig. 2. It consists of a conical cap supported on a central post by two inclined standards. A pipe is attached to the top of the cap. The interior of the cap shows a lamp hanging from a central support.

Fig. 3.

Fig. 4.



TENTS.

R. LAMBERT, Liverpool.—Patent dated October 11, 1852.

Fig. 1.

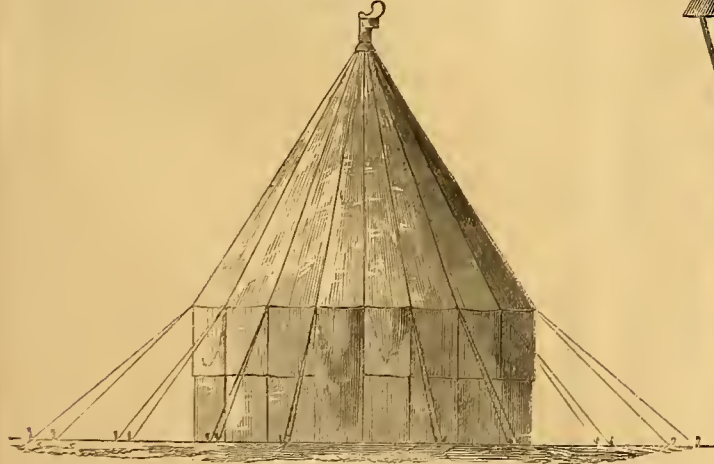

The improvements in tents, specified under this patent, relate to the ventilation of such erections at the top, and to the construction of double

carrying the axis of a rotatory cover cap, with a wind-vane. The figures also show a lamp suspended beneath the cone. By these contrivances, very perfect ventilation is secured.

The whole arrangement of the tent is deserving of much praise for its general excellence even in the most minute details; it is just such a piece of furniture as we should recommend to the intending emigrant.

REGISTERED DESIGNS.

UNIVERSAL TENT, OR SLEEPING CABIN.

Registered for MR. H. HARRISON, SEN., King's Road, Hoxton.

The "universal tent" is intended as a temporary home for the newly-landed emigrant, or for the permanent occupation of the wandering

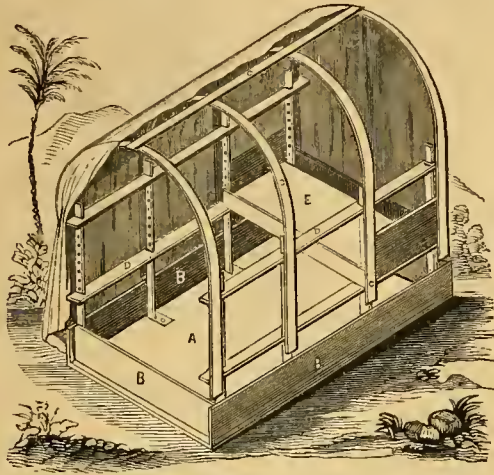

shepherd or gold-seeker. Our figure represents the contrivance in perspective, with the covering partially removed, and denuded of its internal fittings. To the flooring, *A*, the side and end pieces, *B*, are secured by screws; and from this, as a base, the iron stanchions, *C*, stand up and carry the horizontal strengthening pieces, *D*. These pieces rest upon pins inserted in the holes in the stanchions, so that the tent's height is thus easily adjustable. The sleeping place, or bed platform, is at *E*; and if another berth is wanted, it may be placed shipwise upon the second support overhead. The hoops, *F*, support a waterproof tilt, covering the whole of the tent; and the top stay-piece, *G*, secures the upper works from swaying with the wind.

GOLD-SIFTER.

Registered for R. LAMBERT and T. DANBY, Liverpool.

Fig. 1.

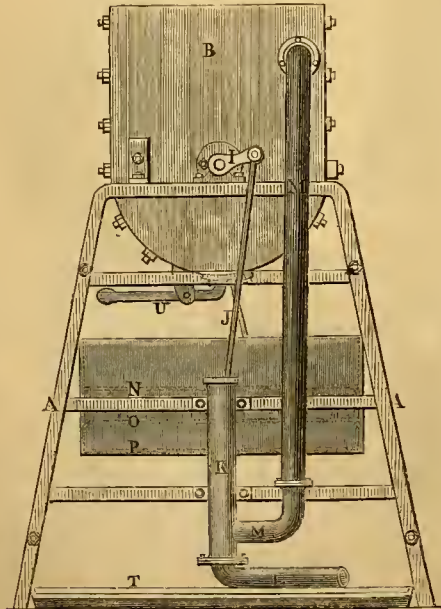

This is another of the many inventions which we owe to the magic of golden Australia. Fig. 1 is a side view of the apparatus; fig. 2

is a front view, and fig. 3 a plan. It consists of an open frame, *A*, carrying a receiver, *B*, in which is a revolving barrel, *C*, set with a series

Fig. 2.

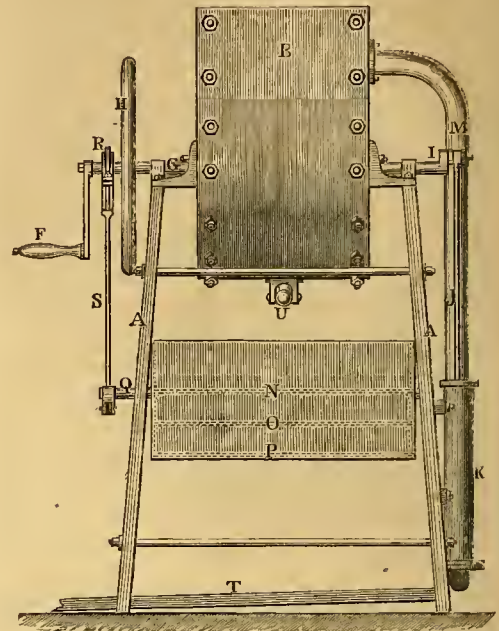

of pins, *D*, working in gear with pins, *E*, fast in the receiver. The pin shaft is driven by the winch, *F*, fast on the shaft, *G*, which carries a fly-wheel, *H*. The other end of the shaft has a crank, *I*, a connecting-rod, *J*, from which passes down to a pump, *K*, for supplying water through the pipes, *L*, and branch, *M*, to the working chamber.

Fig. 3.

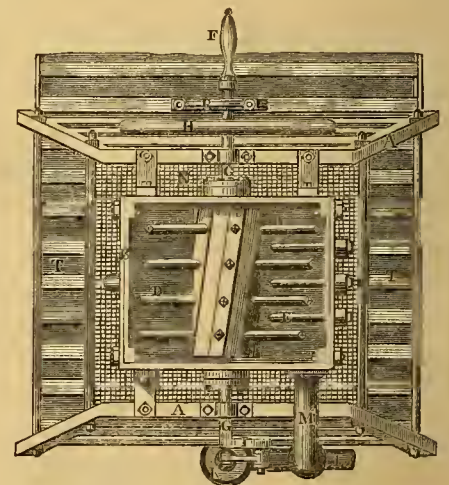

Beneath the working chamber is a box, containing three separate sieves, *N*, *O*, *P*, in a tier, of graduated fineness, and made to oscillate by a lever arm at *Q*, acted on *G* by an eccentric, *R*, on the main shaft, through a rod, *S*. On the groove beneath is an incline, *T*, for running the water away into the reservoir—strips of wood being set across it to arrest any small particles of gold which may escape through the sieve; at *U* is a valve, beneath the receiver, for discharging the agitated mass upon the sieves. This is a very complete and easily worked machine.

REVIEWS OF NEW BOOKS.

ON THE MANUFACTURE OF GLASS. By George Shaw, Esq., Professor of Chemistry in Queen's College, Birmingham. Bogue, Fleet Street.

The subject here very carefully entered upon is one, unquestionably, of high interest. And this interest does not attach less to the present state of the manufacture than to its history, or, we might say, to any particular period of its history. When we glance at the treasures of this manufacture, which are carefully stored up in our various archaeological and educational museums, we are often perplexed to observe this most brittle material surviving in its perfect form, fragile as it naturally is, like those

types of beauty intended to endure for ever in "glorious bronze;" and when we think of the revolutions in art, science, and civil society, which these specimens must have witnessed, the story of the Italian mouk is brought back upon memory, and we are inclined to judge that it is art which is the enduring, and the artist that is the perishable. The extreme antiquity of the material, its plastic character, the colours of every hne, opaque and transparent, with which it is capable of being "furnished forth," form, of course, elements uniting together in one substance completely unique; while, in all its forms, it stands forth as a new creation at the hands of man; for we can discover specimens by searching the archives of art alone. No wonder, therefore, that the contributions of the substance to the stores of the Great Exhibition were many and various, and no wonder that, from the crystal fountain, to the exquisitely-carved Bohemian glass, the public attention and admiration were simultaneously excited. And, of course, the substance is claimed to be separately treated of in this, one of the series of lectures on the results of the great display of nations.

It is not to be disregarded, that the materials combined to form so beautiful a result, are to be found almost everywhere.

Very properly, not confining himself to a particular definition of glass, Mr. Shaw merely notices, that silicic acid, in combining with the oxides of some of the light metals, as potassium and sodium, as well as with those of some of the heavy metals, as lead and hismuth, forms compounds or salts, which, on the application of heat, fuse into colourless transparent liquids, and solidify, on cooling, into hard, brittle solids, having an amorphous or non-crystalline character. Boracic acid, we are also told, forms similar compounds, and it is to such compounds that the appellation, *glass*, is restricted.

If the silicic acid and bases employed were pure, the glass obtained would be colourless; but as this is impossible, the glass has always some tinge of colour—the universally contaminating ingredients being protoxide of iron, which gives a green tint. Mr. Shaw mentions that the neutralizing of this colour constitutes one of the nicest operations in the manufacture of the finest kinds of glass, and is effected by the introduction into the mixture of the peroxide of manganese. The adjustment of the quantity, however, requires very great care, as a deficiency leaves still some green colour, while excess gives a purple tinge.

Of this substance, various kinds are, as is well known, in common use: plate glass, crown glass, and flint glass, being the three principal, if not really the only kinds.

Crown glass is made by the process called *flashing*. The glass having been brought into a cuplike form, and being supported on an axis or *pointil*, is made to rotate rapidly by the turning of the pointil. The tendency which the particles of a rotating body have to fly from the centre of motion, causes the cup gradually to expand, and flatten out to a disc, every part of which, in the hands of a very skilful workman, will occupy a plane perpendicular to the axis of rotation.

Flint glass (so originally called from one of its component parts, silicious sand, having been made by heating flints, and quenching them in water so as to reduce them to powder) is a silicate of potassa and lead, while soda is used for the inferior kind—baryta sometimes taking the place of the lead.

Paste, used for the fabrication of artificial gems, is a silicate of potassa, with an excess of lead as compared with other glasses.

It is in the manufacture of flint glass that the arts of moulding, pressing, cutting, and engraving, are brought to bear.

The lecturer describes these various processes very happily, serving to remind us of every little detail we ourselves observed, when, long years ago, we delighted to stroll into a neighbouring "works," and watch the generation of the various beautiful forms.

Spread glass is produced by the workman first blowing a somewhat cylindrical figure. This partially-formed cylinder is detached from the iron on which it was formed, and the hemispherical end by which it was attached being removed, there is obtained a hollow cylinder, of uniform thickness throughout. A line drawn with a diamond down the interior of such cylinder parallel to its axis, divides it in the course of the line, and, by cautious heating, it may be spread out to a flat plate.

Plate glass is made by removing the crucible in which the glass has been fused from the furnace, pouring the liquid mass on a plane surface, and spreading it thereon by means of a roller; the sheet of glass so obtained being afterwards ground and polished.

Enamels are silicates of potassa or soda, and lead, containing also oxide of tin or antimony; the opaque particles of the latter body giving the required opacity.

The important process of annealing, the lecturer describes as follows:—

"After the glass has been perfectly fused, it is allowed to take the temperature proper to the particular manufacture to which it is to be applied; after it has been manufac-

tured, it has to be annealed. The process of annealing is simply the slow cooling of the manufactured articles. This is carried on in annealing ovens, or lears, one part of which is more strongly heated than the rest. The manufactured goods are first placed in the hottest part of the lear, and slowly removed to the cooler part, many hours being usually required to effect the slow cooling or annealing of articles thick in substance. Thin articles, as figure shades, gas chimneys, require little annealing, and sometimes are not annealed at all. Glass is a very bad conductor of heat; so much so, that when large masses at a red heat are plunged into water, the interior of the mass preserves its red heat for a considerable time, and when quickly cooled, the exterior becomes solid, while the interior is yet soft; the outer solidified portions being fixed, and incapable of shrinking by the contraction of the interior portions as they cool, the whole mass is in a constrained condition, the interior portions of the mass soliciting the exterior part to yield, and the exterior part resisting to an extent dependent on the figure of the mass. The result of this condition in the particles of unannealed glass is, that a slight accidental circumstance, the scratch of a diamond, or a minute fracture of a portion of the external surface, determines the balance in favour of the interior particles, and the consequent rupture of the glass. The converse action occasions the fracture of glass. On the sudden application of heat from the imperfect conducting power of the glass, the external layer expands before the heat reaches the interior, and, by this expansion, the rupture of the interior portions, unable by their cohesion to resist the enormous force by which the external layers expand."

Persons feeling interested in the methods adopted for production of coloured glass, will find them mentioned here with great particularity; but our limits preclude us quoting the passage. Some very valuable observations will also be found in a brief description which the author gives of the methods by which the several contributions of the coloured windows were produced.

It is somewhat singular that the earliest specimens of sheet window-glass which we possess (twelfth century) were made by processes similar to those employed at this day for the same purpose; but the detail of the modern manufacture, improved to perfection, completely eclipses that of our ancestors. "In point of purity of colour and beauty of surface," says Mr. Shaw, "we must occasionally yield the palm to some of our continental neighbours, but in all really essential qualities, the English manufacturer has cause to congratulate himself on the result of the Exhibition." "Generally," he observes in another place, "we excel our continental neighbours in those respects in which excellency is dependent on manufacturing facilities and manipulatory skill." We are glad to find that we are not so bad in this as in some other matters; although it must be observed that the author's praise is very qualified.

Although we have considerably encroached upon our space, we cannot refrain from extracting the following passage, which, we are persuaded, will be read by many of our readers with great pleasure; and, in giving it, we must conclude our lengthened notice of this short production:—

"If we admit, as a canon of criticism in these matters, that, in the application of any material to decorative purposes, those properties which are peculiar to the material in question should be made especially prominent, then we can have little difficulty in deciding on the method of treatment to be resorted to in producing designs for coloured windows. Designs (rude, it may be, but possessing a charm, which, if we may trust the popular voice, the more finished productions of recent times can make no pretension to), were for centuries produced in great numbers, and with great facility, by medieval artists; in these productions, that beautiful property, possessed alone by glass among the many solids used in the manufacturing arts, namely, transparency, never was sacrificed; and, besides possessing a consequent brilliancy, rarely approached in modern times, were really what they were designed for, windows—serving the purpose of illuminating the apartment in which they were introduced. If we glance at the other extreme, we find that no works of art of a high character ever have been, and, from the nature of the material, we may safely say that none ever will be produced. We may almost affirm that the more competent the artist in the ordinary walks of art by whom a design for a window has been produced, the more complete has been the failure. The Great Exhibition has done signal service to manufacturing art, by demonstrating the utter hopelessness of producing pictures in transparent glass; many, it is true, of the exhibited designs showed an excellence of a high order—they were the perfection of their kind. The beautiful figure of Geyling was, perhaps, (if we except a singular oversight in the drawing of part of the figure), unequalled by any rival production; the Dante window, too, was a superb composition. But what, after all the labour bestowed upon them, was their value? They were but transparencies, which might have been executed in a material less fragile, at a title of the cost and trouble. They were glass in nothing but their brittleness. A fine rebuke, whether intended or not, against the over-painting of glass, was administered by the exhibitor of a muslin transparency, which, during the Exhibition, kept its place among the painted windows, and was so undistinguishable from many of its companions, that not one visitor in ten thousand suspected it to be other than glass. How completely must all the characteristics of glass be sacrificed before it can be so counterfeited!"

MUSEUMS, LIBRARIES, AND PICTURE GALLERIES, Public and Private; their Establishment, Formation, Arrangement, and Architectural Construction; to which is appended the Public Libraries' Act, 1850, and Remarks on its Adoption by Mechanics and other Scientific Institutions; with Illustrations by John W. Papworth, Fellow of the R.I. of British Architects, &c. &c., and Wyatt Papworth, Architect, Hon. Sec. of the Architectural Publication Society, and Hon. Member of the Yorkshire Architectural Society. London: Chapman & Hall. 1853. Pp. 80.

We have given the title of this publication *in extenso*, as a concise epitome of the contents. The publication itself is well-timed. As general education enforces itself upon thought, the public mind naturally rests upon the more prominent and agreeable means which collections of objects of vertu, or curiosity hooks and pictures, afford to help it on its way. And here we have laid before the eye, as well as the mind, some very clever observations, which it would be well for all who feel interested in the subject of æsthetic culture, and particularly your committees in-

trusted with the launching of any educational institution of the kind, to get by heart, or remember. Very many, very useful practical suggestions are thrown out throughout the work, extraneous to its more immediate objects, and here and there we can trace the result of an effort to confine the attention to those objects, at the loss of some observations which we would wish to have been made. The authors have nearly exhausted the subject; and we can observe that, with far less labour, they might have produced a much larger volume. Ten large and very well-executed plates of buildings are placed at the end, and many woodcuts are interspersed throughout the text—the whole being “got up,” in the elegant and handsome manner for which even the ordinary publications of this firm have been for some time past renowned.

CORRESPONDENCE.

REMOVAL OF THE VISCOUS CONSTITUENT OF OIL.

In the *Practical Mechanic's Journal* for the present month, I observe an inquiry from a Merthyr correspondent, as to the removal of the viscous constituent of castor oil. As some reply to this, I send you a sample of my *patent mineral oil from tar*, pure and fit for lubrication, without any admixture. Its specific gravity is .970, water being 1.000. This oil will not act upon metals; on the contrary, it tends to preserve them. One-fourth mineral oil, mixed with three-fourths castor oil, produces a good lubricating fluid; and a smaller proportion of mineral oil, mixed with animal or vegetable oils, having less body than castor oil, makes such oils quite equal to sperm.

Glasgow, April, 1853.

GEO. SHAND.

[Mr. Shand's sample of oil is very clear and free, resembling ordinary sperm in general appearance; but we are, of course, without any information as to its behaviour in use. The invention being one of those protected under the new law, the details of the process are yet unpublished. Mr. George Hutcheson, of Glasgow, has just made known his “method of preparing oils for lubricating and burning.” The agent employed in this case is oleic ether, which, mixed with lard or tallow oil, effects the desired fluidity in those ordinarily thick matters. One part oleic ether is added to two parts of neutral tallow-oil; but the patentee states that the proportions are variable, and that the oxides of ethyle and methyle may be used to the same purpose.—Ed. P. M. JOURNAL.]

STEAM-SHIP PROPULSION.

May I beg the favour of a space in your valuable periodical, to submit to your readers the following two suggestions of mine, relating to steam-vessel propulsion?

The first relates to the floats of the common paddle-wheels of such vessels, and the second to the screws. The object of the first suggestion is to prevent the jolting and loss of power caused by the inclination of the floats on their entering and leaving the water, and consists in employing floats curved towards the periphery of the wheel, so as to meet and leave the water in a *tangent*, thus favouring progression, though at some sacrifice in retrogression.

The second suggestion is for an alteration in the thread or blade of the screw propeller, and consists in forming the back of the thread into an angle as acute as possible, instead of being perpendicular to the axis; the object of this being to prevent the great resistance of the water against the back of the thread. The benefit of such form may not be readily admitted, the action of water on the backs of receding bodies not having, I believe, ever received much attention; but it is fully evident that this action has something to do with the motion, as well as has the front action. If the screw acted in the water the same as in a nut or threaded tube, it would be immaterial, with reference to the action on the vessel, whether the thread were shaped one way or the other at the back, the nut or tube being already made for the passage of the screw; but in the water the effect is very different, as then the screw has to *tap* its path by forcing the water away; and during every yard of progress, whatever be the shape of the screw, a cylindrical yard of water, equal to the full diameter of the screw, should be removed out of its place by the action of the back of the thread, which, when the angle is acute, is much more easily done than when obtuse. It must be borne in mind that the screw has two offices to perform—the front part pressing one way, so as to propel the vessel, and the hind part pressing the contrary way, so as to clear away the water; and so effectually do they seem to perform their respective duties, that when the speed exceeds a certain limit, the vacuum is said to be observable in the water.

It appears that a fact exists with respect to the action of screws on vessels, which I have never seen adverted to, and which ought not to escape notice—namely, that they must tend to turn the vessel to one side,

according to the inclination of the thread; but, by placing the screw a little towards one side of the vessel, this defect may be counteracted, as it also may by employing two screws reversed, one on each side.

LEWIS GOMPertz.

[If we rightly understand our correspondent's first suggestion, we have to express a fear that, if the floats were curved, as he directs, they would lift a great quantity of water when emerging.

More is to be gained by giving proper proportions to the common radial paddle-wheel, than by adopting any feathering contrivance. The motion of the paddle-float is compounded of two motions—a tangential motion, due to the rotation, and a horizontal motion, due to the progress of the vessel. The proportions may be such that the combination of these two makes the float enter and leave the water *edgeways*, and the best feathering apparatus can do no more.

With regard to the second suggestion, this question arises—which is the back of the screw blade; that is, its hindermost part, considered as a receding body? Now, supposing there is no slip, the rotation and the onward motion combined, causes the blade to traverse a serpentine path, the width of which is equal to its own thickness; and, therefore, it is the after *edge* which is the hindermost part.

There have been several plans suggested for making the forward edge advance gradually—the cutting edge being inclined to the axis, and in most cases the conformation is such as to make the blade leave the water behind it in a similar manner.

If a screw—a cork screw, for instance—is viewed obliquely, or in perspective, one side appears to have a different inclination to the other. We do not understand our correspondent's last remark, unless he conceives this difference of inclination to be real. It is, however, only apparent; and a screw-propeller, if working in a medium of uniform density, could not possibly turn the vessel to either side.

It is, however, found that the screw does sometimes turn the vessel to one side; but this is considered to be owing to the difference in the density of the water at the higher and lower portions of the screw. Our correspondent's remedy would, doubtless, avail against this.—Ed. P. M. J.]

APPLICATION OF THE PRINCIPLES OF GRAVITATION AND THE DOCTRINE OF RATIOS TO THE MEASUREMENT OF THE SOLAR SYSTEM.

PROBLEM:

Given, the *times* of the moon's revolution in its orbit, and those of the earth in its orbit and upon its axis—the former being sidereal, and the lateral mean solar; from them it is required to deduce the circumferences of both.

		OPERATION:	
	Moon.		Earth.
Logarithm, seconds	= 6.373021	Logarithm, seconds	= 4.9365137
			2
“ square	= 12.746042	“ “	9.8730274
“ × 16 feet	= 1.204120	“ “	1.2041200
“ feet	= 13.950162	“ “	11.0771474
“ ÷ 5280 ft.	= 3.722634	“ “	3.7226340
“ miles	= 10.227528	“ “	7.3545134
“ do.	= 5.113764	“ “	3.6772567
“ do.		“ “	5.1137640
“ do.		“ “	8.7910207
24860 miles = circumference of the earth		“ “	4.3955103
	÷ 3.14159	“ “	0.4971499
7913 miles = earth's mean diameter		“ “	3.8983604
	÷ 3.656	“ “	0.5630370
2164 miles = moon's mean diameter		“ “	3.3353234
	× 3.14159	“ “	0.4971499
6799 miles = circumference of the moon		“ “	3.8324733

The square roots of the quantities, or lines, arising from the given times being multiplied into each other, and the square root of the product extracted, the result is the circumference of the earth, which, being divided by 3.14159, equals the mean diameter; the division of which,

by the square root of the ratio of the "times" of the earth's revolution to those of the moon in their respective orbits, equals the mean diameter of the moon; the multiplication of which, by 3.14159, equals the circumference thereof, as required.

The ratio referred to, equals the logarithm of the *times* of the earth's revolution in its orbit, minus the logarithm *times* of the moon's revolution in its orbit, thus—

Logarithm,.....	{ earth's times = 7.499094 moon's times = 6.373021
"	
"	= 1.126073
"	square root = 0.563037 = 3.656

By this original application of these two well-known principles, not only the circumferences of the planets and the sun, but their mean distances, also, from him, and those of the satellites from their primaries, may be calculated, of which I shall give you an example in my next communication.

The sun revolves upon his axis in precisely the same order as the moon, namely, from *left to right*, which I have ascertained by observing two spots, or openings, on his disc, apparently not far distant from each other, first appearing on the left, and then gradually advancing until they disappeared on the right; a fact which, I think, is not generally known.

J. WHITFORD.

SAFETY ON RAILWAYS.

The continuance, and even increase, of fearful accidents on railways, certainly ought to compel us to investigate more closely the causes, and apply whatever remedies are attainable. These disasters may be enumerated under the following heads:—1st, Collision; 2d, Running off the line; 3d, Boiler explosions; 4th, Fracture of axles; 5th, Fire from engine sparks; 6th, Cattle getting on the line; and 7th, Imprudence in parties crossing the line, and getting in and out of carriages when in motion. Now, all these evils appear to me to be easily remediable. Generally speaking, collisions might be prevented by adopting the plan which I have so long suggested, and for which—and for my wheels for escaping obstacles on common roads—I gained the *Council Medal* of the Great Exhibition. In my plan, the two trains coming into collision politely pass each other, instead of rudely conflicting. Besides this, hells might be fixed at intervals upon the line, and be set ringing for a certain length of time by means of clockwork, governed by the passing trains, so that each train would give satisfactory warning of its position.

Running off the line may be prevented by placing a strong wood or iron rail on the outside of the main carrying-rails, such secondary or guard-rail to be carried up two or three feet from the ground. Boiler explosions might very properly be done away with, by omitting the boiler altogether, and substituting a generator on Howard's plan, or heating the cylinders, and allowing water to fall thereon in drops, to flash into steam. Axle fractures I would render harmless by hindling the carriages to run within an inch or two of the ground, cranking the axles for that purpose. Catching fire would obviously be impossible if the carriages were of iron, or if the chemical means already used to prevent conflagration in other situations were adopted. Cattle could not get on the line if a fence were added to my guard-rail, as proposed in reference to the second head. Individual imprudence in going on the line is an unmechanical difficulty, which I can only touch upon by a recommendation to travellers to take better care of themselves.

LEWIS GOMPERTZ.

London, April, 1853.

PROCEEDINGS OF SCIENTIFIC SOCIETIES.

INSTITUTION OF CIVIL ENGINEERS.

APRIL 5, 1853.

"On Locomotive Boilers," by Mr. J. Sewell.

Resumption of discussion on Mr. D. K. Clark's paper, "Principles of Locomotive Boilers."

APRIL 12.

"On the Concussion of Pump Valves," by Mr. W. G. Armstrong.

APRIL 19.

"Description of the Liverpool Corporation Water-Works," by Mr. T. Duncan.

NOVEMBER 23, 1852.

"On the Drainage of Towns," by Mr. Robert Rawlinson, Assoc. Inst. C. E.

The author, believing the subject of the drainage of towns to be so compre-

hensive, that its full and complete consideration, within the limits of a paper to be read in one evening, would be impossible, restricted his remarks to a few general points, likely to induce discussion and to elicit criticism, on former and present systems.

The historical portion was limited to showing, that in the now disinterred ruins of the most ancient cities, remains of drains had been found, and the Cloaca Maxima formed part of the wonders of ancient Rome.

Politically, the question of sewerage was very urgent, as the general health of the population influenced, to an important extent, the amount of misery, pauperism, vice, and crime existing in every city; and the increasing numbers, as shown by the census, demonstrated the necessity for providing for the extension of all large towns. In 1841, the population of one hundred and seventeen districts, comprising the chief towns, was 6,612,958 souls. In 1851, in the same districts, the number was 7,795,958. Disease had been rife in those districts, but it was shown that much of it might have been averted by timely sanitary precautions.

It was, however, to the social effect of town drainage, that the attention of civil engineers would be most naturally directed, as under that head the leading principles of actual practice, and the proposed modifications, must be brought forward and discussed.

The questions of forms, dimensions, fall, cost, &c., of large and small sewers were passed over, with the remark, that they were matters of detail, to be fixed by the knowledge and experience of the engineer; contending, however, that the system most deserving commendation was that which enabled the greatest extent of sewerage to be well and cheaply accomplished.

The position of the outlet would be governed by natural local conditions, and the dimensions would be fixed by the area and the number of houses to be drained.

The material of construction was a question dependent entirely on experience and practice; earthenware pipes were, however, according to the author's views, the most economical and effective for all sewers and drains within the capacity of the material.

It was contended, that town sewers could not receive the excessive flood waters, even of the urban portion of the site; they should never receive the suburban drainage, nor be combined with watercourses: they should be adapted solely to remove the solid and liquid refuse from the houses; and that it was safer for the inhabitants that there should be no sewers at all, rather than they should be of such dimensions as to become places of deposit. Pumping could be profitably adopted in certain situations, where, from the level, or the effect of tidal influence, the outlet flow might be checked. Intercepting sewers at mid-level were approved. Sewers of minimum dimensions were advocated, in connection with pumping, and they should be capable of resisting internal hydraulic pressure, in case of the water rising in them.

NOVEMBER 30, DECEMBER 7 and 14.

Discussion of Mr. Rawlinson's paper "On the Drainage of Towns."

SOCIETY OF ARTS.

WEDNESDAY, 1ST DECEMBER, 1852.

LORD MONTEAGLE IN THE CHAIR.

Mr. Cole proceeded to deliver his long-promised discourse "On the International Results of the Great Exhibition." After attempting to show that our recent commercial policy had mainly enabled us to realise the cosmopolitan character of the display made in Hyde Park, and exposing the disadvantages likely to accrue to those nations which still maintained to a great extent so-called protective duties, he remarked that the value of a large idea depended on its concurrence with a public want. The idea was promulgated, and all nations seized the opportunity to realise it. The first international result pointed out by the lecturer was that of bringing together, as commissioners and jurors, so many men belonging to all countries who were eminent in the arts, science, and commerce. Such an assemblage, in order to promote the chief objects for which civilized nations exist, was, he said, unprecedented in the history of the world. The men of art, science, and commerce had hitherto had a very subordinate voice in the regulation of their own interests, which had been too much left to the professional superintendence of their brethren of politics, law, and war. This feature of the Exhibition, therefore, was the recognition of a new principle of the highest importance to the progress of mankind. After touching upon the vast sums expended by us in the wars of Europe, for the benefit of the continental powers, he adverted to the apparent ingratitude of some of them, in not following our example as regards free trading. He noticed the acquisition of the Government officials in aiding the endeavours of those who were promoting with new zest the interests of English art and science; and mentioned that both Earl Granville and the Earl of Malmesbury had consented that Downing Street should be the means of communication between the Society of Arts and similar societies abroad, while Earl Grey and Sir J. Pakington had granted facilities of the same kind with reference to the colonies. He drew attention to the efforts which are being made towards the establishment of a cheap and uniform general system, among all the civilized nations, of postal communication, and which promise to be attended with complete success. The recent reform of the patent law did not, of course, escape notice, and the principle of provisional registration, so highly beneficial to inventors, was shown to have been produced entirely from a necessary provision made during the Great Exhibition. He also stated that the American, Belgian, French, and other Governments, with our own, were taking steps to render the specifications of patents of more easy access for consultation. After noticing the magnificent hospitalities of the city of Paris to the Royal Commission, and suggesting the approaching centenary of the Society, and the opening

of the Dublin Exhibition next year, as a proper period to show our French friends some return for their favours, he stated that the council were prepared to take the initiative, and intended, at the same time, to take steps for increasing the facilities of travelling abroad, so as to allow even artisans to avail themselves of them. He alluded to the great building itself as originating a class of architecture of very peculiar character, and which must necessarily be illustrative of the present moving age to all distant times. Proceeding then to notice a point of great importance, relative to the necessity of a greater knowledge of abstract science to our workmen, he remarked that it might be true that other nations were advancing more rapidly than ourselves in the prosecution of abstract science. It was true that, in many parts of the continent, children were more generally educated than our own in reading and writing; but he feared this education turned to little account, as, when they became men, they were not free to read and write what they pleased, and it was said they even lost those accomplishments for want of practice. He did not question the value of abstract science, but abstract science appeared to him one only of many ingredients which were necessary for the prosecution of successful industry. The idea of an international exhibition was one of abstract science, but was in itself of no use without other favourable circumstances enabling it to be realized. As respects the industrial progress of this kingdom, he looked with no alarm at the progress of abstract science abroad, but with satisfaction, because he felt certain, that in the present state of the world, and with that advancing unity of nations, if our neighbours produced abstract science, and if we wanted it, we should be able to obtain it from them on equitable terms, and turn it to good account. He went heartily with the advocates of abstract science, and would help all he could to enable manufacturers to be educated to understand the principles on which their operations were based; but he would do so for the merits of abstract science itself, rather than in alarm at the progress our neighbours might be making in it. The value of abstract science depended on its practical execution, and that, he submitted, depended on the public want for it. At present he saw no reason to doubt that we were prepared in this country to supply well and cheaply whatever the world wanted; and if we supplied the practical execution, and our neighbours the philosophical theory, it might, after all, be a proper division of labour among friends. The French were, on an average, better educated workmen in art-manufactures, but the most impressive lessons in this department came from the East; and in industrial objects we learnt most from our American cousins. Mr. Cole then proceeded to point out some of the chief prospective benefits which the Exhibition, considered as an international display, seemed naturally to promise. He recommended an alliance with the Law Amendment Society, for the establishment of an international commercial law. He urged the importance of an international system of weights and measures, and coinage—a scientific classification of all the materials, instruments, and productions of human art and industry—a more consistent system of international commercial tariffs and customs' administration—the abolition of passports, and increased facilities for international intercourse—a general system of international copyright, both in the arts and in literature, and an international catalogue of printed books. The last point he entered into in some detail, and expressed his confidence that a universal catalogue, on the plan suggested by Mr. Dilke, was a perfectly practical undertaking. Mr. Cole concluded his list of *agendæ*, the prospective fruits of the Exhibition, by alluding to the impulse which better education, and particularly industrial education, was likely to receive from it. Already the intention existed of making drawing a part of our national education, and, in a few years, on a site opposite that where the Exhibition stood, he hoped they would witness the foundation of an industrial university, in the advantages of which all the nations of the earth might equally share. Beyond every result, however, he trusted that the Exhibition would tend to make us a less quarrelsome and less meddling people with other nations than we have been accustomed to be, and would teach us that our true policy in international disputes, should they unfortunately arise, is to stand on the defensive, and, in that attitude, to be content with being as well prepared as possible.

ROYAL SCOTTISH SOCIETY OF ARTS.

MARCH 14, 1853.

"On the Prevalence of Colour-Blindness in the Human Subject, and the limit which it puts to the use of Coloured Signals on Railways at Sea, and elsewhere," by George Wilson, M.D.

"On a new Gas Stove for economically heating Ornamental Tools and Glue; specially adapted for Dressing and Fancy Leather Case Makers," by Mr. John Kolbie Milne.

MARCH 28.

"Suggestions for the Prevention of Railway Accidents arising from Collision," by J. Stewart Hepburn, Esq., of Colquhalzie.

"On some notices of attempts to discover Perpetual Motion," by Daniel Wilson, LL.D., illustrated with Models.

"On means which might be adopted in Public Buildings and Dwelling-houses for the speedy extinction of Fire," by James Stark, M.D.

APRIL 11.

"On Mechanical and other Contrivances for Ventilation, with a description of a new method for Ventilating Buildings by means of Steam Apparatus," by Robert Ritchie, Esq., C.E.

"On Cauterising the Dental Nerve by means of Electricity," by W. A. Roberts, M.D., Edinburgh.

"On an Improved Self-acting Railway Signal, constructed so as to dispense with coloured lights at night," by William Fraser Rae, Edinburgh.

"Description and Drawing of a Safety and Alarm Lock," by Alexander McColl, Auchtermuchty.

MONTHLY NOTES.

THE "BRILLIANT" MADEIRA PACKET BRIG AS AN AUXILIARY SCREW-STEAMER.

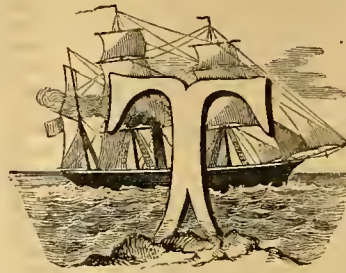

THE "little *Brilliant*," so well known amongst nautical men, as "perhaps the fastest sailing vessel of her size in the world," has just sailed on her first Madeira trip as an auxiliary screw-steamer, having been fitted with a screw and engines of 14 horse power by Messrs. Sumners, Day, & Baldock, of Southampton. Previous to sailing, she was tried in Stokes' Bay, under steam alone, with her masts and spars all standing, and attained a speed of $5\frac{3}{4}$ knots, or $6\frac{1}{2}$ miles an hour. The only object of furnishing her with this moderate amount of steam power, is to afford her the means of self-propulsion in such calms as have not unfrequently kept her for three or four days within sight of Madeira: and this power has been secured to her without any sacrifice as regards pure sailing qualities, as the whole of the added machinery simply fills up the space in her hold formerly occupied by shingle ballast. The screw is fitted with disengaging gear, so that it can be unshipped and hoisted on deck, or lowered and put in gear, in three minutes. Her consumption of coal when on full steam is only rated at two tons per day, and as her steam will only be necessary in occasional calms or head winds, her coal-stowage need be only of very limited extent. Indeed, it is calculated that, under ordinary circumstances, she could easily take fuel enough for an Australian voyage, although only of 373 tons burthen. This beautiful little vessel—the pride of sailors and the boast of yachtsmen—was originally built as a yacht for the Marquis of Donegall. She has now been some years on the Madeira and Southampton station, where she is duly appreciated by all Madeira voyagers. Her new power must serve to make her yet more highly valued.

LIEUT. HEATHCOTE'S EXHAUSTING SIPHONS.—We gave a brief description of this effective contrivance in our February number; but what we then said will be rendered still clearer by the annexed illustrative figure. This sketch is intended to show the application of the siphon to the two distinct purposes for which it has been more especially designed. The vertical centre line of the engraving indicates the existence of two separate halves of a transverse section of a vessel afloat. On the left of that boundary line, a water-boat is shown alongside, the siphon being in

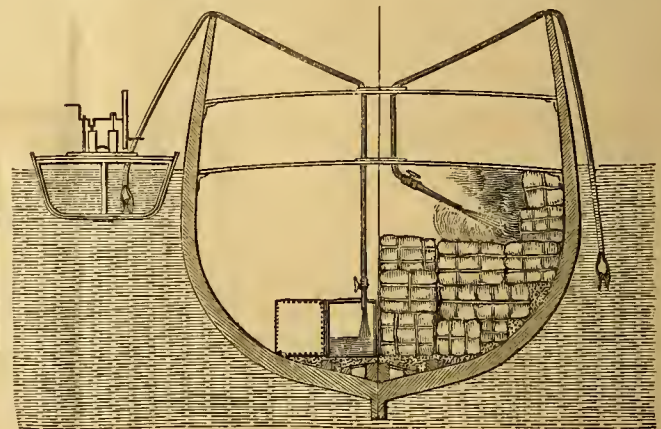

the act of taking the supply of water for the tanks in the hold, without the use of the force-pump. On the right, the siphon is extinguishing a fire amongst some cotton bales, by the aid of water, taken without the slightest mechanical aid, from the sea. It is to be understood that the whole of the pipe is to be immersed, in order to fill it with water; and that the object of the valve is to keep it full when again drawn up. The objections to the fire-engines, which are now carried by all men-of-war, and generally by the better class of merchant vessels, are principally that, being so much exposed to casualties of all kinds, they readily get out of order, and when required for use, are seldom found efficient; that they require time to prepare them, and hands to work them, and that the supply of water they yield is small and insufficient; and then, after all, the labour is, in most cases, entirely thrown away, for whenever the seat of the fire is below the water-line, a siphon would not only answer the purpose, but do so much more effectually than the most powerful fire-engine to be found in ships. The fires which have lately occurred in steam-vessels have originated, in nearly every case, in store-rooms, or other places below the water-line; and there have been cases of spontaneous combustion in coal-laden vessels, where the *fact* of the coal being on fire, though at a distance below the surface, has been known for weeks before it ate its way up to the deck, and finally burst forth; but the short-handed crew having nothing but their buckets, and perhaps a small fire-engine to depend upon for a supply of water, dared not open the hatches to combat with the flames while they were yet in such a position, that could they have availed themselves of the help of a siphon,

the vessel might have been saved. It is to furnish, in such cases as these, an auxiliary at once powerful and simple, that this invention is offered to the public.

QUEEN'S COLLEGE, BIRMINGHAM.—The department in connection with "Arts, Manufactures, and Commerce," is now announced, by advertisement, to be opened in May. The appeal from the College to the noble patrons and friends of education, to enable the Council to purchase expensive philosophical apparatus and models, and to fit up the Chemical Laboratory and Engineering Workshop, has been generously responded to by the Duke of Sutherland, the Earls of Dartmouth, Clarendon, and Granville, the Lords Foley, Calthorpe, Redesdale, Leigh, Lifford, General Vyse, Mark Phillips, Esq., G. Attwood, Esq.; by Messrs. Piercy, Dawes, Bagnall, Barrows, and Hall, and other leading Staffordshire iron-masters; and by Messrs. Welch, Armfield, Uppill, and other influential merchants of the town. Considering the present condition of commercial enterprise, the unrestricted competition to which the trade and manufactures of the country must inevitably henceforth be exposed, in connection with the fact, that systematic education in arts and manufactures is established in some continental states, a cogent argument is supplied that this department, under the powers granted by the Crown to the College, should be energetically carried out, and the recent alarming and numerous accidents in shops, mines, manufactories, and railways, must be allowed to add still farther importance to this branch of education. It must be admitted that no town in the kingdom offers such practical advantages as Birmingham. The Council are also sanguine in their expectations that they shall be able to form—by donations from the public at large, of specimens of mining and mineral products of chemical and pharmaceutical products, of vegetable and animal substances used in manufactures, of civil engineering, architectural and building contrivances, of manufacturing machines and tools, of philosophical apparatus, of models and plastic art—a great "Central Museum," accessible to the artisan, under certain regulations, and subservient to the courses of education in the College, in the engineering, architectural, and chemical branches.

EXPERIMENTS IN SCREW PROPULSION.—The cry of the screw being "still in its infancy," is, as yet, kept up, and is, in a great measure, confirmed by the many endeavors at present making to bring it to maturity. Among the plans which are at present attracting the most attention, are those of Griffiths and Sir Thomas Mitchell, the latter one handled by the sounding name of the 'Boomerang Propeller.' Griffiths' screw has been thoroughly tried in Her Majesty's yacht, *Fairy*, and appears to have given satisfaction. The *Fairy* is considered the best screw steam-vessel in Her Majesty's service, and her present state of excellence has been obtained after trying, for the last few years, every kind and form of screw; and the one used in the trial against the new propeller was a fine polished brass one, and considered the perfection of a screw. The new propeller was simply a cast-iron one, and the first of the kind tried against the *Fairy's* screw. The result of the trials in Stokes Bay seems to have been, that Griffiths' propeller beat the other one by about half a knot. This is not much, but it would have been something even if the new propeller had only equalled the old. There are several novelties in Griffiths' propeller, and it is difficult to apportion the results to their respective causes. The chief improvement seems to be the enlargement of the central boss, it being made of one-third the diameter of the whole screw. The experiments, at any rate, show that this does not lower the efficiency. The vibration at the stern, sometimes experienced with screw vessels, was not felt with the new propeller; but we are not informed if the *Fairy* experienced any vibration with her old screw, and therefore it is questionable if any gain in this respect can be attributed to the new one. The blades of the new screw are made to swivel, and are somewhat different in shape from any before used, being wider close to the boss, and tapering towards the outer edge. The swivelling is not new, but the increased size of the boss gives great facilities for fitting the blades, and making them of sufficient strength. The Boomerang propeller is an instrument of a very different character. It has lately been tried at Liverpool in the *Genova*, and is said to have been successful; but the published particulars are too vague for any opinion to be formed on this point. In shape, the instrument resembles the weapon of the Australian aborigines. Its acting surface is in fact helical, and it differs from the common screw, in having portions cut away, particularly at the centre, and in forming a greater part of an entire convolution. On account of this latter peculiarity, it requires a much larger opening in the dead wood of the ship, which has prevented its being tried in its full integrity. It is said, however, that a Liverpool firm is building a vessel, in which it is to be tried full size. The Boomerang propeller differs very little from many screws patented before it, such as Beadon's, Haddan's, and Fraiset's. Whilst on the subject, we may mention, as another instance of the success of the screw, that on her last voyage home, the *Glasgow* beat the *Hermann* paddle-steamer; the former arriving in the Clyde some hours before the latter reached Southampton, although they left New York together. This is one of the fairest races on record, and exhibits the Clyde-built screw-ship in a most favourable comparison with a full-powered American steamer. The new three-decker, the *Wellington*, the largest man-of-war to which the screw has yet been applied, has just been tried, and has astonished every one with the speed she attained, notwithstanding her comparatively small power. She made upwards of 10 knots.

NEW FORM OF VANE-GOVERNOR.—A novel arrangement of vane-governor, apparently a modification of Mr. Hick's well-known contrivance, has recently

made its appearance in America. It is not yet in actual practice, but our sketch will sufficiently illustrate the inventor's idea. The

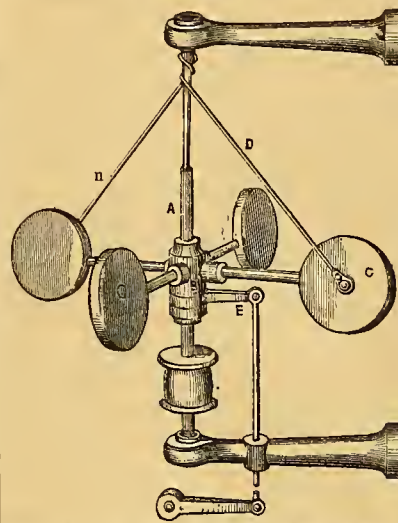

Fig. 1.

vertical spindle, A, driven by a pulley, near its lower end, has upon it a sliding collar-piece, the boss, B, of which carries four radial arms, each of which terminates in a vertical vane, C. A cord, D, is passed through a hole, drilled through the slightly conical top of the spindle, its two ends being directed angularly downwards to two of the vanes, so as to suspend the entire series of four vanes. When the spindle begins to run, the cord winds round it, and thus elevates the sliding-boss of the vanes, until the latter acquire the same rate of revolution as the spindle itself; and whenever the speed of the engine, and, consequently, that of the spindle, A, undergoes any change, more or less of the cord will be wound up accordingly, as the change is for the faster or slower. The

boss, B, thus takes the place of the ordinary sliding-ring of the pendulum-governor, and, as it moves up and down, its action is conveyed by the link, E, to the throttle or expansion valve.

HOUSTON'S IMPROVEMENTS IN JACQUARD MACHINERY.—Mr. James Houston, of Dunfermline, has recently introduced and secured, under the new law, a very important modification of the connections of the jacquard and draw-loom, by which he dispenses with the use of the ordinary leaden or wire weights employed for effecting a uniform tension upon the harness. Instead of crowding the loom with a mass of many thousand weights, which are costly, slow of action, and liable to entangle and wear out quickly, Mr. Houston adopts elastic cords as the medium of connection of the harness with the fixed frame. Fig. 1 of our engravings, is a front

Fig. 2.

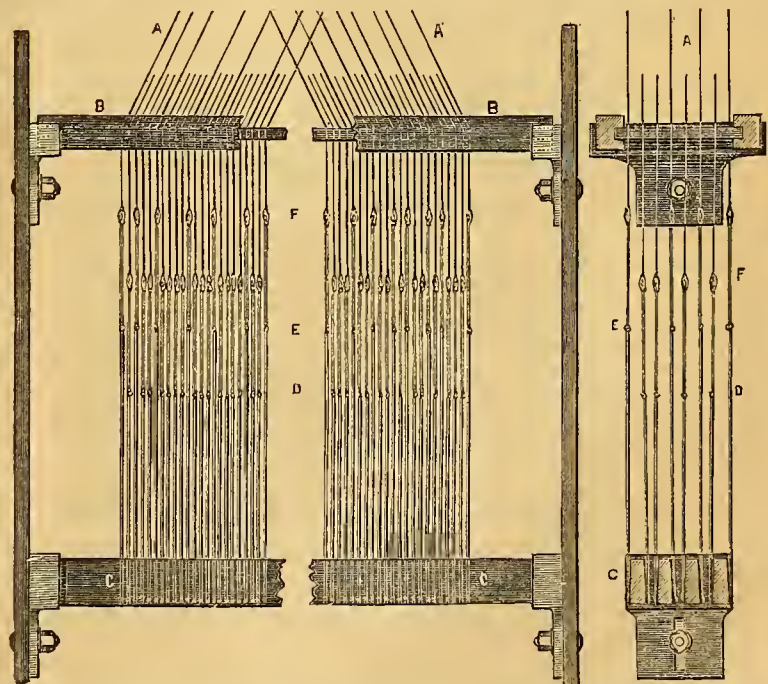

view of a portion of a loom, showing this system of elastic tensional connection. Fig. 2 is a corresponding edge view, at right angles to fig. 1. The tails are represented at A, as descending from the jacquard action, or draw-loom, overhead, and passing through the reed, or holyboard, B, down to the fixed cross-bar, C, beneath. The lengths from D to E, respectively, downwards to the bar, C, are of india-rubber cord—the two levels, D and E, showing that some tails are raised, and others left behind, according as the pattern needles are in or out of their holes in the pattern cards. The portion marked F, above, indicates the heddle connection. By this simple arrangement, the harness is kept at a regular tension under all circumstances of action, whilst the reaction and pendulous motion on

bringing back the tails is entirely prevented, and is much easier on all the top mounting than when weights are used. Several looms have been fitted upon this plan, showing marked advantages in working; and, in particular, that a great increase in the working speed has thus been satisfactorily established.

CURIOSITIES OF MECHANICAL NEGLIGENCE.—We have often heard of boiler-makers leaving tools and waste in boilers after repairs, and thus burning out the bottoms; and we remember an instance of a hammer and chisel being left inside a locomotive engine cylinder, so that the piston forced off the cover when the engine began to move. But a far more unfortunate incident of a like class occurred last month in a steam-tug on the Tyne, where the foreman engineer left a wooden plug in the steam-pipe of one of the boilers previous to getting up steam. The vessel was the *Engineer*, and she was lying off Tynemouth Bar at the time, on a trial trip. The evidence shows that two workmen had been engaged in fixing the steam-pipe to the starboard boiler a few days before the trial trip, and they had used a large plug of wood to retain the pipe in position, and prevent the running of the cement into the boiler. One of the men took out the plug when the job was over, but his foreman instructed him to replace it until the cement hardened. The men then went to another piece of work, and the foreman most unfortunately and forgetfully screwed up the pipe with the plug still in it. Of course, when steam was got up, something must give way, and luckily, under the circumstances, it was the fire-tube only that burst. Had the boiler fully exploded, all on board must have been killed; as it was, nine persons were severely scalded, and one poor fellow, a joiner, was killed. The foreman escaped with a reprimand. Indeed, our censures ought to be mingled with some pity for the self-condemning position in which he has placed himself.

INTERNATIONAL SOCIETY OF INDUSTRY, AGRICULTURE, AND COMMERCE, (VEREENIGING VOOR VOLKSVLIJT,) AT AMSTERDAM.—The seeds sown by the Great Exhibition in this country are constantly up-springing. All nations were pupils in that grand school of "industrial education;" and the more apt of the students are now giving us examples of their progress. The United States, Prussia, and other states, and Ireland, have already shown what they can do; and we have now to include Holland in the list. During the past month, an active agent, Mr. J. Sieburgh, has visited the chief seats of our manufactures, bringing with him detailed statements of what the people of Holland are prepared to do in furtherance of all objects connected with "industry, agriculture, and commerce," by organizing a comprehensive undertaking in the city of Amsterdam. The following extracts from the prospectus of the scheme, which Mr. Sieburgh has laid before us, will afford better information as to the intentions of the society, than we can give in any other way:—

"The international exhibition of 1851, not only proved to us the amazing results of the application of the sciences upon the various practical and technical arts, agriculture, commerce, and navigation, but showed us the immense importance of a speedy, well-regulated, liberal, and more scientific intercourse betwixt the different nations of the civilized world. Our society has been formed to pursue this beneficial direction. Its object is to establish a direct connection between practical and industrial men, both in this kingdom and abroad, and to introduce and diffuse all foreign discoveries that have come to its knowledge. In order to attain this, the society intends—

"1st. To open public exhibitions of all such products of nature and of art, and such objects of industry as will be found adapted for the purpose; for which purpose several large rooms have been opened, until a building for Great Exhibitions shall be completed.

"2d. To take upon itself the charge of ordering, receiving, and sending into depot, or taking into consignment, all objects interesting for national industry, which may be either demanded of the society or offered to it.

"3d. To give advice and information in reply to every inquiry addressed to the society, respecting agriculture, industry, and commerce.

"4th. To take charge of petitions for patents, and to promote, by every possible means, the application of inventions or discoveries under letters patent.

"The society has correspondents in every town in the kingdom and its colonies, with the view of thus promoting its object, and also of assisting in the distribution of the articles that are sent in for exhibition. It is under the immediate distinguished patronage of the much-respected Prince Frederick of the Netherlands, and numbers the most eminent and celebrated men in the country among its members. It is, moreover, favoured by the high approbation of his Majesty, King William III., and by the concurrence and co-operation of the Government and other high authorities. Premiums are awarded to all important objects that are sent in, and the expenses of conveying such objects are reimbursed. The society is also prepared to exchange samples, patterns, and models, and the like, with other proprietors of scientific or technical collections. For the value of the objects sent to the institution, every security can be obtained; and for every article that has been sold through its agency, ready money will be paid."

"Extract from the Regulations for the Exhibition and the Members.

"Art. 20. All objects connected with industry and agriculture, and adapted thereto, are to be publicly exhibited.

"Art. 21. The Board of Directors has the power of refusing any particular object that may have been sent in, and likewise to fix the period for the exhibition.

"Art. 22. Those who have contributed objects, enjoy free admittance to the exhibition during the time those objects remain exposed.

"Art. 23. No person may claim the return of an exhibited object, within a period of six weeks from its arrival.

"Art. 24. The society provides for the convenient placing and for the proper care of all the objects exhibited, and will be responsible for damages or injury, unless due notice to the contrary has been previously given to the contributors, by letter, on receipt of the object.

"Art. 25. The contributors are obliged to specify what they wish should be communicated to the visitors of the exhibition, concerning the objects that they have sent in; likewise whether they are for sale, and at what prices.

"Art. 26. The contributors will be allowed to place, on their account, persons near the exposed objects, in order to explain them or to set them in motion, provided, by so doing, no injury be caused to the other objects. But, at the same time, such persons must be approved of by the directors, who have the power to refuse their admission.

"Art. 27. Without the special permission of the contributors, no one will be allowed either to make experiments upon any object exposed, or to take designs from them.

"Art. 28. Objects, the exhibition of which might be useful in other parts of the kingdom, are sent into such parts, to the resident correspondents, who, in such cases, are to provide for suitable localities.

"Art. 37. Any person may become a member of this society on application by letter.

"Art. 38. The members have free admission to the library, the museum of trade, and the exhibition.

"Art. 45. The foreign members receive written communications of every important or interesting alteration, or discovery, or improvement, &c. &c., introduced into this country, in that department for which they have been inscribed.

"Art. 48. The price of subscription for foreign members is fixed at 30 shillings, or £18 per annum."

Such is an outline of this very meritorious movement. Amongst the foreign correspondents of the society in this country, we find the names of William May, Esq., 127 Fenchurch-street, London; William Johnson, 47 Lincoln's-Inn-Fields, London, and Glasgow; Francis Morton, Esq., Liverpool; Professor Sullivan, Dublin; Professor Hodges, Belfast; and Messrs. Hughes and Bloodworth, Manchester. We shall make our readers acquainted with the future proceedings of the undertaking, as they become further developed.

PROVISIONAL PROTECTIONS FOR INVENTIONS UNDER THE PATENT LAW AMENDMENT ACT.

When the city or town is not mentioned, London is to be understood.

Recorded January 31, 1853.

264. Charles Cattanch, Aberdeen—Certain apparatus for measuring the human figure, and transferring the said measurement to cloth.

Recorded February 25.

482. John G. Taylor, Cheapside—Improvements in ornamental fastenings for dress.

Recorded March 1.

510. William E. Newton, Chancery-lane—Improvements in capstans.—(Communication.)

Recorded March 3.

532. Robert Barelay, Montrose—Improvements in rotatory engines for obtaining motive power, and for transmitting aeriform bodies and fluids.

Recorded March 7.

575. Augustino Carosio, Montague-street—Invention of a hydro-dynamic battery, or new or improved electro-magnetic apparatus, which, with its products, are applicable to the production of motive power, of light, and of heat.

Recorded March 9.

595. Samuel Blackwell, Oxford-street—Improvements in saddlery and harness.

596. François Valtat and François Marie Rouillé, Rue Ramhuteau, Paris, and 4 South-street, Finchbury—Improvements in the construction of the combs of looms for weaving.

597. Joseph Shuttleworth, Stamp End Iron Works, Lincoln—Improvements in appendages to portable machines for thrashing, shaking, and winnowing corn.

599. George Chambers, Cheapside—Improved means of gathering cinders and depositing ashes under fire-grates, securing economy in fuel, and cleanliness of appearance.

601. George Collier, Halifax—Improvements in the manufacture of carpets and other fabrics.

603. Henry Ransford, Chelsea—Improvements in the manufacture of starch.

605. George Collier, Halifax, and Samuel Thornton, same place—Improvements in spinning, roving, doubling, and twisting cotton, worsted, flax, and other fibrous materials.

606. Frederick W. Campin, Strand—Invention of an instrument for measuring the steering way of vessels, and the rapidity of currents of water and air, applicable to ventilating ships and railway carriages.—(Communication from Messrs. Owerduyn and Droinet.)

Recorded March 10.

607. James Walmsley, Scout Newchurch, near Manchester—Improved machinery and arrangements for hock printing.

608. John Powis and Jahus S. James, Watling-street—Improvements in machinery for slotting, tenoning, morticing, grooving, drilling, boring, and vertical planing.

609. Edward T. Bellhouse, Manchester—Improvements in iron structures.

610. Thomas B. Dodgson, Upper Clapton—Improvements in roads or ways, pavements, and footpaths generally.

611. George Collier, Halifax—Improvements in machinery or apparatus used in weaving

612. Hon. William E. Cochrane, Albany-street, and William M. Cochrane, Kingston—Improvements in girths or pads for retaining saddles in their places.

613. François F. Dumarchey, Paris—Certain improvements in making roads and ways.

614. James Stevens, Southwark Bridge-road—Improvements in apparatus for facilitating communications between the guard and engineman of railway trains.

615. Emanuel Myers, Ramsgate—Improvements in preventing railway engines and carriages running off the rails.

Recorded March 11.

616. Francis Preston, Manchester—Improvements in the manufacture of hobbins and spools.

617. James Summers, West Cowes—Improvements in certain kinds of sails.

619. Moses Poole, Avenue-road—Improvements in apparatus for serving oysters and other shell-fish.—(Communication.)

Recorded March 12.

620. John Gilby, Beverley—Improvements in fire-arms.

621. William Muir, Manchester—Improvements in machinery or apparatus for grinding edge tools and other articles.

622. Peter Armand Le Comte de Fontaine Moreau, 4 South-street, Finsbury, and 39 Rue de l'Échiquier, Paris—Invention of a new or improved apparatus for filtering liquids.—(Communication.)
623. John F. Heather, Woolwich—Invention of an equitable gas-weighing meter.
624. Auguste E. L. Bellford, Holborn—Improvements in machinery for cutting standing crops, and gathering the same into sheaves or bundles.—(Communication.)
626. Thomas Evans, the younger, 18 Tooley-street, Southwark—Certain improvements in the construction of steam boilers.
627. George Michiels, Holywell-street—Improvements in obtaining oxygen for manufacturing purposes.
628. Thomas Hunt, Leman-street—Improvements in the construction of sights for fire-arms.
629. Thomas Rhodes, Leeds—Improvements in the manufacture of manure.
630. Robert C. Witty, Wandsworth-road—Improvements in the manufacture of gas.
631. James Murdoch, 7 Staple-inn, Middlesex—An improved construction of portable voltaic batteries.—(Communication.)
- Recorded March 14.*
632. William Quinton, Benjamin Quinton, and John Quinton, Birmingham—Improvements in the construction and manufacture of measuring rules.
633. Right Hon. Charles A. Lord Howard de Walden and Seaford, G.C.B.—Invention for whitening and cleansing sugar by the application of steam and hot air in a centrifugal sugar machine.—(Communication.)
634. William E. Staité, Manchester—Improvements in apparatus for producing and applying current electricity, parts of which apparatus are applicable for obtaining and treating certain chemical products resulting from electrolytic action.
636. Bennett A. Burton and Henry M. Burton, Blackfriars-road—Improvements in the mode of manufacturing casks, vats, and other like vessels, and in the machinery or apparatus to be employed for such purpose.
638. John H. Johnson, 47 Lincoln's-inn-fields, and of Glasgow—Improvements in dyeing.—(Communication.)
639. John Scott, jun., Greenock—Improvements in the treatment or manufacture of animal charcoal.
640. William Stevenson, Johnstone, Renfrew—Improvements in the treatment or manufacture of textile materials.
641. William Basball, jun., Preston—Improvements in dressing, sizing, and tape machines.
- Recorded March 15.*
642. William Morgan, Spencer-street, Shoreditch—Invention for the manufacture of a portable double-action folding chair.
643. Thornton J. Herapath—Improvements in treating sewage, and in manufacturing manure therefrom.
644. Pierre Sigisbert L'Hermault, and Jean Richard, Paris, and of 16 Castle-street, Holborn—Improved means for unhooking horses, and impeding or stopping vehicles on common roads.
645. François Durand, Paris, and 16 Castle-street, Holborn—Invention of an improved kind of loom.
646. Joseph Mandslay, Lambeth—Improvements in screw propellers for ships and other vessels.
647. Perceval M. Parsons, Duke-street, Adelphi—Improvements in working the valves of steam-engines.
648. Ephraim Sahel, 25 Broad-street-buildings—Improvements in the construction of looking-glasses, and in the apparatus connected therewith.—(Communication.)
- Recorded March 16.*
649. George Knight, Birmingham, and John Heritage, Warwick—An improvement or improvements in drying bricks, and such other articles as are or may be made of clay.
651. Charles H. Wild, St. Martin's-lane—Improvements in fishes and fish-joints for connecting the rails of railways.
652. William Malins, Savile-row—Certain improvements in the application of atmospheric propulsion upon railways.
653. Henry R. Fanshawe, Arthur-street, Old Kent-road—Improvements in fire-arms.
654. Samuel Colt, Spring-gardens—Improved apparatus for beating and annealing metals.
655. John Oliver, Newcastle-upon-Tyne—Improvements in the manufacture of a red pigment, commonly called Venetian red.
- Recorded March 17.*
657. John Livesey, New Lenton, Nottingham—Improvements in piled and looped fabrics, in cutting and finishing such fabrics, and in the machinery employed therein.
658. John T. Ashehurst, Upper John-street—Improvements in piano-fortes.
659. William Blakhorn, Sutton, Lancaster—Improvements in the construction of furnaces and annealing kilns employed in the manufacture of glass.
660. George Johnson, Stockport—Certain improvements in looms for weaving.
661. James Roscow, Bolton-le-Moors, and Robert Bullough, same place—Certain improvements in machinery or apparatus for raising water and other fluids.
662. John Bottomley, Bradford—Improvements in the manufacture of figured or ornamented piled or plashed fabrics.
- Recorded March 18.*
663. Richard Peters, Southwark—An improved machine for mortising and tenoning, drilling and boring.
664. James Tweedale, Abraham A. Tweedale, and Samuel Tweedale, Rochdale—Certain improvements in machinery or apparatus for spinning cotton and other fibrous materials.
665. Paul Cameron, Glasgow—Improvements in marine and surveying compasses.
666. William K. Westly, Leeds—Improved comb or gill for heckling, drawing, roving, and otherwise preparing to be spun, bemp, flax, tow, silk, wool, and other fibrous substances.
667. John H. Johnson, 47 Lincoln's-inn-fields, and Glasgow—Improvements in steam-engines.—(Communication.)
668. Malcolm Baxter, Glasgow—Improvements in steam-engines and pressure-regulating valves.
669. Richard A. Brooman, 166 Fleet-street—Improved machine for weighing or measuring and packing spices, drugs, coffee, and like matters.—(Communication.)
670. Auguste E. L. Bellford, 16 Castle-street, Holborn—Improvements in power-looms.—(Communication.)
671. John Haskett, 52 Wigmore-street, Cavendish-square—Improvements in grinding stones and whetstones.—(Communication.)
673. Charles Harratt, 2 Royal Exchange-buildings—Improvements in strengthening the masts of ships and vessels.
674. Robert O. Christian, Havre—Certain improvements in bed-hangers, for ships carrying emigrant passengers, and in the manner of manufacturing them.
675. Robert O. Christian, Havre—Certain improvements in ventilating.
676. Alfred W. Banks, 42 Newgate-street—Improvements in the manufacture of life-belts.
677. George Ross, Hatton-garden—Improved manufacture of lubricating oil, and a mode or modes of applying such oil to the purposes of lubrication.—(Communication.)
678. George Mackay, Enckingham-street, Strand—Improvements in the manufacture of iron.—(Communication.)
679. Robert B. Tennent, Gracechurch-street—Improvement in the machinery employed for pulping coffee.—(Communication.)
- Recorded March 19.*
680. John Elridge, 9 Stanley-street, Pimlico—Invention for washing woollen, linen, cotton, silken, bemp, skin, and flaxen materials and substances, and called "the rotary washing-machine."
681. Joseph Haley, Manchester—Improvements in the method of transmitting communication from one part of a railway train to another.
682. Henry Bousquet, 157 Fenchurch-street—Improvements in the manufacture of manure.
683. George Dalton, Himley, near Dudley—Certain improvements in smelting or reducing iron ore, iron stone, or slag or scoria.
684. John H. Johnson, 47 Lincoln's-inn-fields, and Glasgow—Improvements in regulating steam-engines, and other prime movers.—(Communication.)
685. Samuel Radcliffe, Oldham, and Knight W. Whitehead, same place—Certain improvements in machinery or apparatus for grinding or setting the surfaces of cylinders and rollers employed in carding engines.
686. Alfred V. Newton, Chancery-lane—An improved construction of oil lamp.—(Communication.)
- Recorded March 21.*
687. James Fraser, Gracechurch-street—Improvements in the manufacture of portable packages.
688. William W. Collins, Buckingham-street—Certain improvements in looms for weaving.—(Communication.)
689. Thomas Sykes, Castleford, Yorkshire—Improvements in the treatment of soapy and greasy waters.—(Communication.)
690. Moses Poole, Avenue-road, Regent's Park—Improvements in generating steam and other vapours.—(Communication.)
691. Jean M. Durnerin, Paris—Improvements in apparatus for extracting liquid out of solid substances, specially applicable to the treatment of fatty matters.
692. Moses Poole, Avenue-road, Regent's Park—Improvements in obtaining power where air is employed.—(Communication.)
693. Isaac Taylor, Stamford-Rivers—Improvements in machinery for printing woven and other fabrics.
694. John Barsham, Kingston-upon-Thames—Improvements in apparatus for communicating between the guard and engine driver, or other persons, in a railway train.
695. John Brett, Camden-town—An improved portable sketching apparatus for artists.
696. John Stather, Kingston-upon-Hull—Improvements in printing.
- Recorded March 22.*
697. Edwin Maw, Seacombe—An improvement in the mode of connecting sheets of corrugated iron, when used in the construction of roofs, iron houses, and other purposes.
699. Thomas Bouch, Edinburgh—Improvements in signals.
700. John H. Johnson, 47 Lincoln's-inn-fields, and Glasgow—Improvements in the mode of smelting iron and other ores.—(Communication.)
701. William Johnson, 47 Lincoln's-inn-fields, and Glasgow—Improvements in rolling and shaping malleable metals.—(Communication.)
702. Nicholas G. Norcross, Lowell, U.S.—Certain improvements in machinery for planing or reducing boards or timber.
703. Frederick Futvoye, Regent-street—An improved apparatus to be employed in games of chance.
704. Henry H. Henson, Hampstead—An improvement or improvements in buffers.
- Recorded March 23.*
705. James Allen, Manchester—Certain improvements applicable to the safety-valves of steam-boilers or generators.
706. John H. Park, Preston, and Joseph Park, same place—Improvements in water-closets and urinals.
707. Jean B. Massat, 16 Castle-street, Holborn—Certain improvements in the manufacture of knives, and other similar handle instruments.
708. Bernard Boyle, 2 Raven-row, Mile-End—Invention of a centripetal flange.
709. Hesketh Hughes and William T. Denbam, both of Cottage-place—Improvements in pianofortes, organs, seraphines, and other like musical instruments.
710. William M. Crossland, Beaumont-street—Improvements in block-making machinery.
711. Antoine F. J. Claudet, Regent-street—Improvements in stereoscopes.
- Recorded March 24.*
712. Charles W. Siemens, Adelphi-terrace, and Joseph Adamson, Leeds—Improvements in rotatory fluid meters.
713. John Beaumont, Dalton, near Huddersfield—Invention of a new manufacture of certain descriptions of woven fabrics.
714. William P. Sharp, Manchester—Certain improvements in machinery for spinning and doubling cotton and other fibrous substances.
715. Robert Grundy, Hindley, and James Jones, Warrington—Improvements in machinery for preparing, spinning, and doubling cotton, and other fibrous materials.
716. Charles V. F. de Roulet, Paris—Certain improvements in the manufacture of piled figured fabrics by alterations in, and additions to, looms for weaving, including also a warping machine, with a method of reading and arranging the colours or materials for the patterns of such figured fabrics.
717. Henry Webster, Sheffield, and Edward D. Stones, same place—Improvements in the construction of gas stoves.
718. William Keates, Liverpool—Improvements in the manufacture of tubes and mandrels.—(Partly a communication.)
719. Charles A. Holm, 21 Cecil-street, Strand—Improvements in propelling vessels.
720. George I. Jackson and Henry D. Jackson, 46 Castle-street, Liverpool—Improvements in fasteners for huttons.
721. William McNaught, Rochdale—Certain improvements in steam-engines.
722. William Edie, Dundee—Improvements in the treatment or manufacture of textile materials.
723. Robert Walker, Glasgow—Improvements in working and increasing the safety of railways.
- Recorded March 26.*
724. Erasmus Symonds, Great Bell Alley—An improved self-acting plug for barges, boats, and other vessels.
726. Robert Hazard, 14 Lincoln's-inn-fields—Invention of a Podombrosfonton, or an improved apparatus for either sponge or shower bath, and all lavatory purposes.
728. Thomas Smedley, Holywell—Certain improvements in steam-boilers.
730. Richard A. Brooman, 166 Fleet-street—Improved rag-tearing and separating machine.—(Communication.)
731. George Robb, Glasgow—Improvements in the manufacture of sulphuric acid, alkalis, and their salts.
732. James Worrall, junior, Salford—Certain improvements in the method of preparing, treating, and finishing, cut, piled, or raised fustians, and other similar goods or fabrics, and in the machinery or apparatus connected therewith.
- Recorded March 28.*
733. George O. Asbury, Birmingham—An improvement or improvements in the manufacture of dowls used in joinery.
734. John G. T. Campbell, 13 Lambeth-hill, Upper Thames-street—Certain improvements in ships' propellers.

735. David S. Brown, 2 Alexandrian-lodge, Old Kent-road—Certain improvements in engines to be worked by steam, or any other elastic fluid, which invention also includes the apparatus for generating such steam, or other elastic fluid.
736. Augustin C. Bernard and Jacques M. P. A. de St. Roman, 4 South-street, Finchury—An improved mode of giving publicity.
737. Thomas J. Perry, Lozels, near Birmingham—Improvements in printing.
738. John Scott, jun., and George W. Jaffrey, both of Greenek—Improvements in steam-engines.
739. Samuel Fox, Deepcar, near Sheffield—An improvement in the frames of umbrellas and parasols.
741. George E. Dering, Lockleys—Improvements in the manufacture of certain salts and oxides of metals.

Recorded March 29.

742. Samuel Bayliss, Old Broad-street—Improvements in the construction of ships and vessels.
743. James Webley, Birmingham—Improvements in the construction of repeating or revolving and other pistols and fire-arms.
744. Luke Smith, Littleborough, and Matthew Smith, Heywood—Improvements in machinery for weaving and printing.
745. Thomas Hill, Southampton—Certain improvements in springs, and also in the modes of their application to railway engines and carriages.—(Communication.)
746. Samuel Newton, Stockport—Invention of a self-acting friction break, to be applied in engines, carriages, and waggon used on railways.
748. Robert Heath, Betley—Improvements in railway breaks and signals.
749. Isaac Rider, Bristol—Improvements in cocks for drawing off beer or other liquids.
750. Lawrence F. Keogh, Liverpool—Improvement in looms for weaving.
751. John Gray, Glasgow—Improvements in the application of heat for haking.
752. William Henham, East Peckham—Improvements in ploughs.
755. John Pym, Pemlico—Improvements in the permanent way of railways.
756. George Shaw, Allen-street, Sheffield—Improvements in the manufacture of knives and forks.
757. Julian Bernard, Guildford-street, Russell-square—Certain improvements in boots, shoes, and clogs, and in the machinery or apparatus and materials connected therewith.
758. John C. Hadden, 29 Bloomsbury-square—Improvements in railway carriages.

Recorded March 30.

759. Martin Billing, Birmingham—Invention of a new or improved method of constructing the walls of houses, hothouses, and other buildings, which said method is also applicable to the construction of fences.
760. William Henham, East Peckham—Certain improvements in regulating the draft in chimneys and other outlets for smoke, air, and vapours.
762. James Bowron, South Shields—Improvements in the manufacture of crown, sheet, plate, and bottle glass.
763. Christopher Nickels, York-road—Improvements in weaving narrow fabrics.
764. Robert Dalglish, Glasgow—Improvement in dyeing.
765. John C. Ramsden, Bradford—Improvements in looms for weaving.
766. Joseph X. Villiet, aîné, Boulevard du Temple, Paris, and 4 South-street, Finchury—Certain improvements in the production of aerated liquids.
767. James Houston, Dunfermline—Improvements in weaving.
768. James Worrall, junior, Salford—Certain improvements in the method of preparing, treating, and finishing certain textile fabrics called cords, thicksets, velveteens, and beaverteens.
769. Lot Faulkner, Cheadle—Certain improvements in the method of obtaining motive power.

Recorded March 31.

770. William A. P. Aymard, 4 South-street, Finchury—Certain improvements in applying to illuminating the extract of bituminous products of coal, peat, and lignites, and in rectifying and depriving the essences and greasy matter from coal.—(Communication from P. J. Salomon, Paris.)
771. Joseph Rylands, Kingston-upon-Hull—Improvements in yards and spars of ships and other vessels.
772. Robert McGavin, Glasgow—Improvements in the construction of ships' masts, yards, booms, and in spars.
773. George Hanson, Huddersfield, and David Chadwick, Salford—Improvements in apparatus for measuring gas, water, and other fluids, which improvements are also applicable for obtaining motive power.
774. John Radcliffe, Bradford—Improvements in looms for weaving.

Recorded April 1.

775. George F. Wilson, Belmont, Vauxhall, and James F. Lee, same place—Improvements in the manufacture of night-lights and their cases.
776. George F. Wilson, Belmont, Vauxhall—Improvements in treating certain oily matters, and in the manufacture of oil.
777. Bartholomew Brittain, Waterloo-road, Surrey—Improvements in the means of supporting or retaining headsteads or other articles of furniture in their proper positions.
779. William Crofts, Nottingham-park—Improvements in weaving.
780. Jonathan Saunders, St. Job's-wood—Improvements in the manufacture of railway tyres.
781. Henry Spencer, Henry Tattersall, and Hugh Simpson, Rochdale—Certain improvements in machinery or apparatus for preparing and spinning cotton and other fibrous materials.
782. Robert E. Peterson, Tottenham-court-road—An improved piston.—(Communication.)
783. George F. Wilson, Belmont, Vauxhall—Improvements in the manufacture of cloths, and in the preparation of wool.
784. George F. Wilson, Belmont, Vauxhall—Improvements in treating certain greasy matters, and in the manufacture of candles.
785. George F. Wilson, Belmont, Vauxhall—Improvements in the manufacture of night-lights, and in apparatus to be used therewith.

Recorded April 2.

787. George Holcroft and William J. Hoyle, Manchester—Certain improvements in steam-engines.
788. George Robb, Glasgow—Improvements in the manufacture of sulphuric acid, alkalis, and other salts.
789. Nicolas Barthelemy, Paris—Improvements in apparatus for sharpening razors.
790. Albion R. Snelling, Tottenham—An improved emigrants' habitation cart.
791. Christopher G. Rosenkilde, Christiansand—Improvements in window sash fastenings.
792. Frederick W. Mowbray, Bradford—Improvements in doubling wool and other fibrous substances.

Recorded April 4.

793. William E. Newton, 66 Chancery-lane—Improvements in engines to be worked by air or gases.—(Communication.)
794. James Fudlow, Manchester—Improvements in beds or couches for sick persons.
795. Joseph Falin, Liverpool—Improvements in apparatus applicable to evaporation and distillation.

796. William E. Newton, 66 Chancery-lane—Improvements in producing plates or surfaces which may be used as printing or embossing surfaces, or as door plates, dial, or number plates, or other plates or surfaces bearing inscriptions or devices of various kinds.—(Communication.)
797. William B. Johnson, Manchester—Improvements in steam-engines, and in apparatus connected therewith.
798. Robert W. Siever, Upper Holloway, and James Crosby, Manchester—Improvements applicable to looms for the manufacture of textile fabrics.
799. Jesse Ross, Keighley, York, and Thomas R. H. Ross, Leicester—Certain improvements in machinery or apparatus for combing wool, cotton, silk, flax, and other suitable fibrous materials.
800. George H. Brockbank, Crawley-street, Oakley-square—Improvements in horizontal piano-fortes.
801. William Walker, Leeds—Improvements in drying malt.
802. Moses Poole, Avenue-road, Regent's-park—Improvements in winding silk from the cocoon.—(Communication.)
803. Francis Steigewald, Munich—Improvements in the manufacture of glass and porcelain.
804. Charles May, Great George-street—Improvements in machinery for manufacturing and rolling iron.
805. Francis Steigewald, Munich—Improvements in heating furnaces.
806. Antoine Burg, Paris—Invention of certain instruments, apparatus, and articles, for the application of electro-galvanic and magnetic action for medical purposes.
807. John Lawson, Biggar—Improvements in the suspension and management of ships' boats.
808. Alfred V. Newton, 66 Chancery-lane—An improved construction of self-inking stamping apparatus.—(Communication.)

Recorded April 5.

810. William Mavity, Birmingham—A new or improved method of manufacturing letters and figures to be used as printing type, lettering for sign and window-boards, and other such like purposes.
812. George Purcell, Cork—A new method of adjustment in the art of printing, by means of certain combinations of various sized spaces and quadrats.
814. James Long, Gorleston, Norfolk—An improved method of setting up and adjusting ships' rigging of all tonnage.
816. Joseph Haley, Manchester—Improvements in machinery or apparatus for forging, stamping, and cutting iron or other substances; which machinery or apparatus is commonly called a "Steam Hammer."
818. William Johnson, 47 Lincoln's-inn-fields, and Glasgow—Improvements in weaving, and in the machinery employed therein.—(Communication.)
820. John Thomas, Caen, France—Improvements in apparatus for the manufacture of gas and coke.

Recorded April 6.

822. Edward Simons, Birmingham—Improvements in telegraphing or communicating signals.
824. James J. Pratt, Long Eaton, Derby—Certain improvements in stockings.
826. Henry A. Jowett, Sawley, Derby—Improvements in apparatus for heating, which improvements are particularly applicable for generating steam or evaporating solutions, and may be applied for heating purposes generally.
828. William Johnson, 47 Lincoln's-inn-fields, and Glasgow—Improvements in the production of ornamental surfaces in glass, porcelain, metals, and similar materials.—(Communication.)
830. Samuel Denison and Henry D. Denison, Leeds—Improvements in rating, breaking, and scutching flax, hemp, and other fibrous matters.

Recorded April 7.

832. William A. P. Aymard, South-street, Finchury—Certain improvements in the preparation for, and application to the manufacture of candles, and other purposes, of certain fatty and resinous bodies or substances.—(Communication.)
834. John Grist, New North-road, Islington—Improvements in machinery for the manufacture of casks, barrels, and other similar vessels.
836. William H. Wells, Edward Mann, and John Harman, all of Wandsworth—Improvements in grinding wheat and other grain.
838. Colin Mathie, Salford—Improvements in power-looms.
840. Frederic Le Mesurier, Pau, Basses Pyrénées, France—Improvements in apparatus for measuring and indicating a given period of time.
842. Christopher Nickels, York-road, Lambeth—Improvements in machinery for masticating, kneading, or grinding india-rubber, gutta percha, and other matters.

DESIGNS FOR ARTICLES OF UTILITY.

Registered from 11th March to 14th April, 1853.

- | | | |
|------------|------|---|
| Feb. 11th, | 3422 | C. Hodgson and J. Stead, Salford,—“Self-adjusting tongs for gas-fitters.” |
| Mar. 11th, | 3431 | W. Brooks, Aldgate,—“Sausage-machine.” |
| 16th, | 3432 | G. Clark, Kingston-on-Hull,—“Seamless block boot.” |
| 21st, | 3433 | G. Dowler, Birmingham,—“Inkstand.” |
| 23d, | 3434 | Brooker and Son, Edmonston,—“Carriage-step and cover.” |
| 24th, | 3435 | J. J. Catterson, Islington,—“Carriage-spring.” |
| 30th, | 3436 | D. J. L. B. Vandenborch, Bruxelles,—“Extending table.” |
| — | 3437 | W. Duck and W. Wilson, London-road,—“High-pressure cock.” |
| 31st, | 3438 | W. J. Clapp, St. James's,—“Hollow and solid bullet-mould.” |
| — | 3439 | J. Cawood and J. Sunter, Derby,—“Valve-lever and ferrule.” |
| — | 3440 | J. Skudder, Deptford,—“Gold-diggers' dwelling.” |
| April 5th, | 3441 | Mrs. Groom, Walworth,—“Abdominal belt.” |
| 6th, | 3442 | Marsh Brothers and Co., Sheffield,—“Table-knife.” |
| 7th, | 3443 | J. Fryer, Charing-cross,—“Despatch-box.” |
| — | 3444 | J. C. Gunn, Edinburgh,—“Collar for pipes.” |
| 13th, | 3445 | J. Paterson, Wood-street,—“Shirt front.” |
| 14th, | 3446 | F. J. James, Adde-street,—“Duckle.” |

DESIGNS FOR ARTICLES OF UTILITY.

Provisionally Registered from 18th March, to 8th April, 1853.

- | | | |
|------------|-----|--|
| Mar. 18th, | 497 | J. Bagnall and S. Limebeer, St. Pancras,—“Portable house.” |
| 20th, | 498 | F. H. Elwin, Camden-town,—“Gun and shot.” |
| April 5th, | 499 | S. Harris, Houndsditch,—“Shirt.” |
| 8th, | 500 | J. Simons, Birmingham,—“Writing-case and taper-stand.” |

TO READERS AND CORRESPONDENTS.

WINTER'S PATENT PADDLE.—This is very ancient. See Kibble's Patent, amongst others.

RECEIVER.—“Proposed London Railway between the City and the West,” by P. M. Parsons.—“Decision in the Great India-Rubber Case of Charles Gonyear.”—“Speech of the Hon. Daniel Webster in the Great India-Rubber Suit.”

C. G. AYT.—Any respectable bookseller will procure the work; the “P. M. Journal” agent, for instance.

ELECTRIC

LAMP.

DR WATSON.

PATENTEE, LONDON.

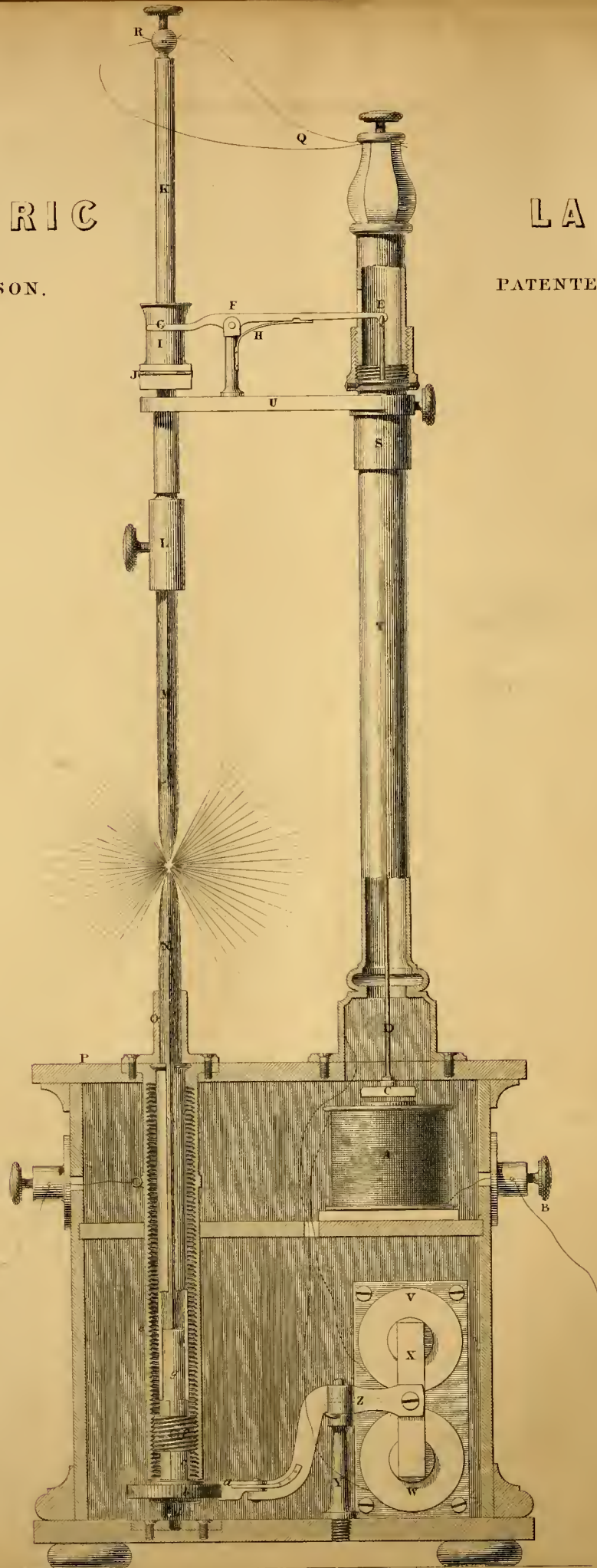

ELECTRICAL ILLUMINATION.—DR. WATSON'S ELECTRIC LAMP.

(Illustrated by Plate 125.)

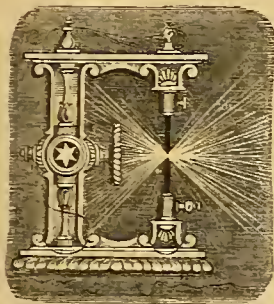

ELECTRICAL illumination is undeniably one of the "modern instances" of the nineteenth century. It is now more than a mere scientific, though scarcely yet a really commercial fact. And its pursuit well deserves the attention which it has received, for the phenomena developed in it are as attractively striking in the estimation of the philosophical inquirer, as are its prospective practical results in that of the whole human race. Voltaic

electricity, which we have studied so much—and of which, in spite of the combined exertions of many labourers through years of unceasing toil, we yet know so little—has presented no feature more likely to contribute to the best interests of mankind, than its production of artificial light. None has enlisted more experimentalists, and certainly none has so well kept up the primarily excited interest in the face of so many failures. It has all along played the part of the *ignis fatuus*, constantly remaining beyond our reach—whilst it yields all the allurements of promised successes necessary for giving piquancy to the pursuit. It waits long, but its turn comes; for every little fact laid bare by individuals, who are singly weak, is turned to good account in that union which gives strength to isolated inquiries.

The wonderfully brilliant character of the electric light is known to every one. Its production on the lecture table, or in a street lamp, for an hour or two's effective display, is no novelty. It differs from all other artificial lights in the fact of its exact reproduction of the light of day; and all this arises from the simple combustion of two pieces of charcoal in contact with the poles of a galvanic battery. These carbon points have received the name of "electrodes." When they are placed in the line of the battery wire, they are first to be brought into actual contact, and then very gradually separated, when a brilliant stream of light is passed. Sir H. Davy has shown that, with a very powerful battery, the light will pass through the great length of four inches. When the light has been kept up for a few minutes, a transfer of particles takes place from one pole, or charcoal point, to the other; and after a while, a cavity is perceptible on one of the charcoals corresponding exactly to a convexity on the opposite point. The gradual combustion of the transferred particles continually increases the distance through which the current has to pass; and as the current's power of so passing is limited to the strength of the battery, the light is necessarily extinguished when the hiatus preponderates.

Again, the actual battery current varies very considerably in working; and hence, if the poles remain at a steady distance of separation, the steadiness of the light must be vitiated from this cause alone. In none of the earlier mechanical combinations for reducing the philosophical experiment to practical use, was any expedient introduced as a remedy for these vitiating effects; and all that has been done, up to the present time, has been the adaptation of mechanical arrangements for the gradual and uniform approximation of the charcoal points by clockwork. Hence, with such arrangements, the points steadily approach each other during the action of the light, wholly irrespective of the strength of the passing current; so that nothing is gained by the device, seeing that there is no concerted connection between the state of the current and the traverse of the points. It is here where Dr. Watson's invention comes in with important advantage. By this newly-patented arrangement, the electric current is itself made the regulating agent of

the light, just as Watt's rotatory pendulum watches every minute variation in the speed of the steam-engine, and, unassisted, applies the necessary remedial action, for at once bringing about the intended understanding between the speed and the work.

The substitution of a magnet for the clockwork movement was the most important step towards the reduction of the electric light to practical use; but, hitherto, the perfection of uniform action attainable by the judicious management of this magnetic movement has been utterly missed. Permanent magnets, indeed, cannot grapple with the difficulties of the case; an electro-magnet, which shall be either an actively attracting body, or a dull powerless piece of iron, accordingly as the electric current is present or absent, alone supplies the automatic principle required for obtaining a steady light. But this is not all—for many mechanical difficulties present themselves in setting the electro-magnet to work as a perfect regulating adjustment for the movement of the electrodes. These difficulties Dr. Watson has most ingeniously overcome, and he is now enabled to burn his lamp for any consecutive number of hours; whilst, within the lamp itself, he has a means of increasing or diminishing the light; the light is restrained to one point, and is therefore adapted for ordinary reflectors; and no previous adjustment is necessary for lighting at any time, when the electrodes have been once fixed.

Our plate, 125, contains a side elevation, partially in section, of this lamp, as arranged for the table and domestic use. In this lamp an electro-magnet, *A*, is fixed in the base, and rendered magnetic by a wire which enters at *B*—the other end of the coil of the magnet being in connection with the lamp's base. The armature, *C*, of the magnet is attached to the lower end of the rod, *D*, which again is connected at its upper end with the longer arm, *E*, of an overhead lever. This lever works on a fixed centre, *F*, and its opposite arm terminates in a fork, *G*, whilst a slight blade-spring, *H*, serves to keep the end, *E*, of the lever constantly elevated when the magnet is not in action. The fork, *G*, embraces a collar, *I*, consisting of two semi-cylindrical pieces of brass, hinged to each other at their base, *J*, and made to grasp the vertical spindle, *K*, by the ascending action of the fork upon the conical sides of the collar. The spindle, *K*, is fitted with a socket, *L*, in which is a tightening screw for holding the upper electrode, *M*; whilst the lower electrode, *N*, is inserted in the stationary socket, *O*, on the base beneath. This socket is fitted into the top of the main stand, *P*, which also carries a binding screw, for connection with one pole of the battery. The dark parts of the figure represent the insulated points of the apparatus. Two flexible wires, *Q*, connect the top of the lamp with the upper electrode, through the binding screw, *R*, in the top of the spindle, *K*, and this completes the battery connection, as far as regards the actual light apparatus.

As the correct working of the lamp depends on the adjustment of the arc, or striking distance between the poles, Dr. Watson has introduced the apparatus indicated at *S*, consisting of a collar piece, or boss, capable of turning round on a shoulder on the upper portion of the pillar, *T*, through which pillar the rod, *D*, of the armature, *C*, is passed. This boss is formed internally with a screw-thread, working upon a corresponding thread on a tubular piece within, so that, on turning the boss, the screw action elevates the tube, and the latter carries up the bracket, *U*, and with it the lever, *E*, *G*. Thus, by turning this boss, *S*, in either direction, the armature, *C*, suspended from the lever, is made to approach to, or recede from, the poles, and thus diminish or increase the inductive power; and the portion of the pillar above the boss being slotted, to allow the lever to pass through, the lever's play is restrained within certain determined limits. The action of the lower pole of the lamp is this:—The current which induces the magnetic power in the magnet, *A*, also brings into action the electro-magnet, *V*, *W*, before it passes to the general body of the lamp. The electro-magnet, *W*, attracts the armature, *X*, which is attached to a curved lever, capable of horizontal motion on the stud pillar, *Y*, but restrained from connection with the magnet,

whilst induction is not going on, by the spring, *z*. At the opposite end of this bent lever is a spring-catch, *a*, gearing with a ratchet-wheel, *b*, which it turns, on being acted upon by the magnetic induction. This ratchet-wheel, *b*, is fast on the end of a slotted tubular piece, *c*, which works in a footstep, *d*, in the base of the stand. This tubular piece, *c*, passes up the centre of the fixed external tube, *e*, which has an internal screw-thread upon it, and is therefore, in reality, a long nut. In this nut is fitted the short externally screwed piece, *f*, which is entered upon the tubular spindle, *e*, and connected with it by a feather projecting into its groove. In this way, as the ratchet, *b*, is turned, the short screw, *f*, is compelled to traverse along its internal screw-thread, and a propeller piece, *g*, on the front of the screw, *f*, pushes forward the electrode, *x*, through the tube, *e*, in which it is entered, and through the socket, *o*. This ingenious movement, which will be recognised as one extensively adopted in existing mechanical contrivances, is similar to that equally ingeniously employed by Mr. Pinkney in his continuous or ever-pointed pencil. The electrode in Dr. Watson's arrangement answers to the lead in that of Mr. Pinkney, as described in another part of these pages.

Thus, the action resulting from the magnetic operation of the magnet, *A*, induces a similar consequence in the action of the magnet, *w*, with the exception that, in the latter case, the movement is an ascending, instead of a descending one. Hence, by the simultaneous action of both poles, the centre of the light is constantly kept at the same level, so that it will unvaryingly correspond with the focal line of a reflector. In the light-action of the lamp itself, the electric current, in passing through the magnet, *A*, attracts the armature, *B*, thereby drawing down the end, *E*, of the overhead lever, and elevating the collar, *I*, and spindle, *K*; and the electrodes are thus retained at a proper distance asunder, so long as a sufficient amount of attraction exists between the magnet and armature to keep the latter down. Should any non-conducting matter obstruct the passage of the electricity through the arc, the induction of the magnet at once ceases, and the spring, *U*, coming into action, forces up the end, *E*, of its lever, causing the opposite end to relax its grasp upon the collar, *I*. The spindle, *K*, then necessarily slides downwards, and re-establishes contact between the electrodes, the requisite arc being instantly re-formed by the attraction of the armature, as before.

The late public displays of the lamp which we have engraved, have satisfactorily established the correctness of the inventor's conceptions. The power which is capable of lighting up the night with all the splendour of open day—carrying, indeed, the brightness of sun-light into the innermost recesses of darkness—is now permanent, steady, and unflinching. It has ceased to be a useless wonder of brief existence, in entering upon a fixed routine of servitude under the sovereignty of man.

What we have described forms but a part of Dr. Watson's inventions, which are now being brought before the public by the "*Electric Power and Colour Company*." These improvements—comprehending a superior system of battery, the production of valuable pigment colours from the battery action, a pure electrode, the desulphurization of coke, and the manufacture of an innocuous and commercially valuable bleaching liquid—we shall reserve for a future paper.

In maturing the beauties of the present, Dr. Watson has given us a glimpse of the splendour to be realized from the future. To that future must we now look for the elevation of what has been hitherto considered an intellectual toy—to a lofty niche of universal usefulness—for, "by the side of the pleasure derived from knowledge already attained, there subsists, not unmixed with melancholy, the longing of the aspiring spirit, still unsatisfied with the present, after regions yet undiscovered and unopened. Such longing draws still closer the link which, by ancient and deep-seated laws of the world of thought, connects the material with the immaterial, and quickens the interchange between that which the mind receives from without, and that which it gives back from its own depths."*

THE EXHIBITION OF THE ROYAL ACADEMY.

The paintings this year are far above the average. It is significant to observe that this is owing, not so much to talent and genius which have for years been approved, as to the successful efforts of our rising artists. When, indeed, a great worker bangs back for a year, as Sir Edwin Landseer and others did in the past season, it is expected that he should come forward with something extraordinary to make up for the pleasure he has debarred us of; yet, when we notice the unwearied industry of the comparative youngsters in the arts, and find them gradually increasing the number, and bettering the quality of their productions, it is easy to trace that the great merit of this exhibition is due to the influence of the secondary rather than of the primary bodies. The total number of works is 1465, of which 1302 are from the easel. The President of the Academy presents two of these to notice. "Ruth sleeping at the feet of Boaz," and "Violante," neither of them greatly attractive: the former, nevertheless, a very pleasing picture. Our distinguished animal painter has four pictures—all of excellence. The principal ones are called "Night" and "Morning;" being a fight between two stags by moonlight, ending at break of day in the death of one, and a dying condition in the other. There are two points, however, which are neither in good thought nor taste. The painter has made a very grave-looking frog a conspicuous spectator of the night combat, and he has had the affectation of placing the scene of the long struggle and destruction in the very same little pool of water, which was not necessary for his subject, and is beyond all bounds of probability. The buck on the right, in the first picture, is a masterpiece of power, and so is the fox in the second picture; but the presence of the latter rather subtracts from the horror meant to be conveyed in the more carnivorous bird lingering after its coming prey. The "Children of the Mist," represented by six deer in a mist, is very happily conceived, and as happily executed. "Twins"—twin lambs and twin shepherd dogs—is rather a fine though a pleasant picture, although the lamb on the left is brought upon the canvas in a marvellous way. David Roberts has five pictures of very unequal merit, and much in his usual style. "The Cathedral of St. Stephen, Vienna," is a noble subject, but very carelessly painted, which is not all that can be said against "Venice;" for here we have not only carelessness but positive error—in drawing and in colour. Whoever has been at Venice will know that the Great Campanile is not approaching even to red in local colour, and that the façade of the Ducal Palace has something more redeemable to notice than rough diamond markings over it. The artist could scarcely have looked at the buildings. "A Street in Verona" is better, but not as it should come from Roberts. This single work might well have occupied him all the time he has taken in painting the others, including "The Inauguration of the Great Exhibition." "Bethlehem, looking towards the Dead Sea," is a redeeming work of this great artist, and shows upon what subjects he might best excel, and where alone a just fame may be found subsisting in the coming time, when a picture will be considered a painting, and not a rough sketch. Stanfield shows two works only. "The Victory, with the body of Nelson on board, towed into Gibraltar," and "An affray in the Pyrenees with Contrabandistas," both of high and rare merit, and showing all his wonted excellence of treatment. In the former, however, the two boats in a line on the right give a formality to the picture which we should like to have seen away. It is nevertheless a grand work. The latter is like a reminiscence of the old scene painter at Drury Lane; but the sky-effect is simply monstrous, for no such sky ever was. Uwins, the friend of our boyhood, comes forth literally in shining colours. "The Thorny and the Flowery Path," is his single contribution, and reminds one of a class of productions rapidly passing away. The colouring of this picture is unequalled in the Academy. Mr. Cooke again charms us with some of his carefully-drawn personifications (if we may so call them) of Venice. As we turn the eye from these productions to the very different subjects of the "Zuyder Zee—Fishing Craft returning to Port," and "The Pier and Bay of St. Ives, Cornwall," it is impossible not to be struck with the versatility of talent and admirable drawing universally shown by this gentleman. His Venetian subjects differ much among themselves, and they are all completely distinct from his paintings of Dutch and English scenery—and yet how excellently treated! To those who know the climate, "San Pietro in Castello, Venice, and the Julian Alps, on a November evening," is like a coloured photograph, and might be coupled with those nameless beauties which are observed by the genuine artist scattered about in nature, and are drawn together by him into his particular work. We scarcely know which of his pictures to admire the most, for each confirms the fame he has acquired, and proves that the honours of the Academy, but lately accorded to him, have been bestowed most worthily. We would particularly claim attention to his "San Georgia, Maggiore, and the Salute, Venice, with fishing-craft of Chioggia, and of the Lagune"—than which there is not a more careful

* Humboldt.

study among all the pictures here exhibited. The characteristic sail of many colours makes us feel, as well as see, that it is Venice before us, while the racking of the boat in the foreground (if, by-the-by, it be proper to call it foreground to a water scene), and the multitudinous contents of the hold, are painted only as Mr. Cooke can paint such things. Mr. Cope by no means pleases us this year. In "The Mother's Kiss," the left of the child's face is quite out of drawing. "Mother and Child" is not a picture which such an artist should exhibit, although the hand of the mother, in this miniature, is exquisitely rendered both in form and colour. His more ambitious subject of "Othello Relating his Adventures," attracts regard only from its unconventional treatment. None of his other three pictures are worthy of this artist. Mr. C. Landseer gives a somewhat new reading of "The Iron Mask." Another single contribution by an R.A., very carefully coloured, and in many parts more than making up for our loss, in this respect, of Etty. A very fine picture of "Waterloo," by Mr. George Jones, merits, as it cannot fail to attract, great interest. It is full of matter for the artist and the philosopher. Mr. Ansdell, the rising Landseer, exhibits what may be done by genies coupled with industry. No English artist has risen more rapidly and worthily in public estimation than this gentleman; and both of the pictures he exhibits, one of which has already been engraved, stamp him for future honours, such as his brethren of the craft may bestow. Mr. E. M. Ward, this year, has two subjects, each of high historical interest, finely conceived, and finely painted. We, however, prefer that of "The Executioner tying Wishart's Book around the neck of Montrose at the time of his Execution," to "Josephine Signing the Act of Divorce," which latter, it is fair to say, seems to be the general favorite. Mr. Ward, we see, cannot fail to be among the next R. A.s, as Mr. Millais and Mr. Ansdell must succeed them. Mr. W. J. Grant also deserves great praise for his "Incident which led to the Great Reformation"—a very sweet picture. Mr. M'Innes deserves similar eulogy for his very interesting subject of "Metastasio, when a child, discovered by Gravina, singing extemporaneous verses in the streets of Rome." Mr. Lance's "Fruit," as usual, says, "Come, eat me." How is it that this artist is not in the Academy? Our old favourite, Stark, and his son, contribute several very pleasant scenes. The latter is improving; he has only to work—work—work—to be among the best of them. Mr. Hannah is among the lazy ones; we trust it is not his health that deprives us of more than one subject—"The Tête a Tête"—from his easel, very nicely painted. An interior of Rosslyn Chapel, showing the Apprentice Pillar, by Mr. Swarbrick, deserves notice, for the treatment of the architectural detail. It ought to have had a better place than the floor. Mr. Millais this year completely outruns all his co-re-Raphaelites. Both his pictures are owning first places in public estimation. "The Order of Release, 1651," and "The Proscribed Cavalier," are great improvements on the painted veins of leaves, which never can be painted. We are rejoiced to see Mr. Millais rising into the region of the highest art. Is it impossible to turn an English Raphael, who, uniting the drawing of Urbino with the grace of Coreggio and the colour of Ruhens, shall superadd the impression of healthy sentiment? We answer, No.

It is very remarkable, that there is not one of all the pictures illustrating "Uncle Tom's Cabin" worthy of the least regard—many of them, indeed, outrage all propriety; and the only wonder is, how they found places on the walls.

Sir W. C. Ross's miniatures, as well as those of Mr. Thorburn, display their well-known excellence. The family of the Right Hon. H. Labouchere, M.P., by the latter, is one of his best works—a very charming group, indeed, of three little girls.

The other portraits comprise several very admirably painted by Sir J. W. Gordon, and those of Mazzini, Richard Cohen, Sir Charles Napier, Walter Savage Landor, the Duke and Duchess of Montpensier, the Archbishop of Canterbury, the Marquis of Anglesea, Sir James Clark, George Dawson, Sir David Brewster, William Hamilton, Edward Forbes, Mr. Brockedon, Sir Harry Smith, Power (the sculptor of the Greek Slave), the Rajah of Coorgh, the Countess Gigliucci (Madame Clara Novello), by Mr. W. W. Scott, very exquisitely designed; Mr. Webster, R.A., by the same artist, a faithful portrait, and others.

The architectural designs show nothing remarkable, with the exception of Mr. Falkener's Pompeian Studies, which are novel and interesting.

There are likewise but very few fine specimens of art among the sculpture and models. Monti has another veiled figure, which, no doubt, will receive many admirers. Looking at the one side (which is veiled) of the face, the deception is more striking than that encountered in the celebrated Veiled Vestal of the Great Exhibition. Mr. MacDowell's "Day Dream" is the *chef d'œuvre*. A bust of her Majesty, by Mrs. Thornycroft, also merits admiration, for its elegant and truthful treatment. There are also busts of Albert Smith, Samuel Rogers, and Douglas Jerrold, and of his Eminence Cardinal Wiseman.

ASTLEY'S LIFE OR SURF BOAT.

An important contribution to the science of life-boat building has just been made by P. H. Astley, Esq., of Stratford, Essex, who is now actively and meritoriously engaged in disseminating a knowledge of his plans throughout the country. The model boat constructed by the inventor is

Fig. 1.

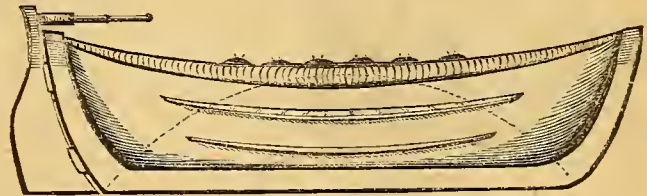

twenty-seven feet long, nine feet beam, three feet eight inches deep, and is capable of carrying fifty persons with safety. Our engraving exhibits four detailed views of the boat. Fig. 1 is a side elevation; fig. 2, a longitudinal section; fig. 3, a reversed plan; and fig. 4, a transverse section. Her bottom is formed with a hollow central chamber, A, running from stem to

Fig. 2.

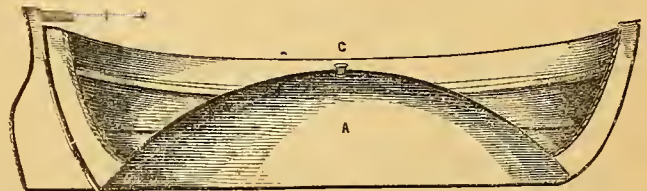

steru; the width of this chamber, or cone, as Mr. Astley terms it, being three feet eight inches amidships, and the depth from the bottom of the keels to the centre, three feet. With this in the middle, she has, of course, two keels, B, eight inches deep, converging from the centre towards each end, where they join. This cone, being filled with air, imparts a far greater

Fig. 3.



amount of floating power than has been otherwise attainable by any previous system; and whilst she cannot be turned over by any ordinary means, neither can she be sunk, even if her sides should be stove in or cut down to her flooring, as the great buoyant air-cone would remain perfect. The compression of the external atmosphere causes the cone to act as a sucker,

Fig. 4.

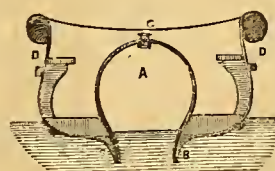

and hence arises the great holding power which prevents her from canting or turning over, whenever she touches the water—no matter how crowded she may be. This cone has also another beautiful effect, for by it the boat's buoyancy may be nicely modified to any point. For this purpose a stop-cock is fitted at C, in the head of the cone, so that air may be pumped in to drive out the water; or conversely, water may be admitted to ballast the boat. When filled with water, she draws only twenty inches, so that, as long as the cone holds, she cannot go down. Although obviously built for safety alone, and with many had points as regards sailing, the boat now at Deal has done fourteen miles under two hours in a rough sea. The projecting ribs, D, on each side are buffers; and beneath these is a hand rail, or rope, to afford an external hold. We hope to see the invention very widely adopted, when its merits become more fully known.

RENSHAW'S PATENT COMPOSITE CUTTING TOOLS.



INCE we noticed Mr. Renshaw's invention in our part for February last, we have prepared a few additional remarks for the elucidation of some further points in connection with the subject. Its essential features consist, as will be remembered, in the combination of the ordinary circular-cutting motions and arrangements of the lathe, with the rectilinear action of the planing or shaping machine, or their derivatives. The composite principle may be applied to most of the machine tools used in the different branches of useful and ornamental manufactures, so as to open out a new field in the arrangement of constructive machinery. Thus, in the case of the lathe, for example, it is applicable not only to the execution of the various kinds of plain work which we have instanced in our former

notes, but also to the beautiful, though subservient, branch of complex or geometrical turning. For instance, if the sliding bar carrying the slide-rest be worked by an unadjustable crank-pin, working in a slot in the end of the bar, or by changeable cams, the revolutions of the crank being proportioned to those of the lathe mandrel by the interposition of the ordinary change-wheels of the lathe, most of the varieties of work hitherto produced only by complicated and isolated kinds of lathes may be executed—as eccentric, elliptical, swash, rosc, cycloidal, and others; the tools, cutters, or drills being applied either to edges or surfaces, or angularly, by the adjustment for the fast headstock, while to vary the pattern it is simply necessary to alter the proportions of the wheels.

Comprehensiveness is a prominent feature in this invention; some of the individual parts, like the machines themselves, serving for several uses, and thus favouring simplicity; so that a lathe, embracing the above functions, for instance, may still possess the steadiness and convenience necessary for the ordinary plain work of the amateur. The engineer and mechanic do not require these ornamental curves, but each may introduce the system of change-wheels in conjunction with the composite lathe, or cutting tools for various uses, besides the ordinary ones of sliding, screw-cutting, and boring, as for finishing cams, snails, spirals, and volutes of various kinds, for barrelling and tapering work, whether circular or rectilinear, and for planing dovetails, V's, and other angular work.

notes, but also to the beautiful, though subservient, branch of complex or geometrical turning. For instance, if the sliding bar carrying the slide-rest be worked by an unadjustable crank-pin, working in a slot in the end of the bar, or by changeable cams, the revolutions of the crank being proportioned to those of the lathe mandrel by the interposition of the ordinary change-wheels of the lathe, most of the varieties of work hitherto produced only by complicated and isolated kinds of lathes may be executed—as eccentric, elliptical, swash, rosc, cycloidal, and others; the tools, cutters, or drills being applied either to edges or surfaces, or angularly, by the adjustment for the fast headstock, while to vary the pattern it is simply necessary to alter the proportions of the wheels.

Fig. 1.

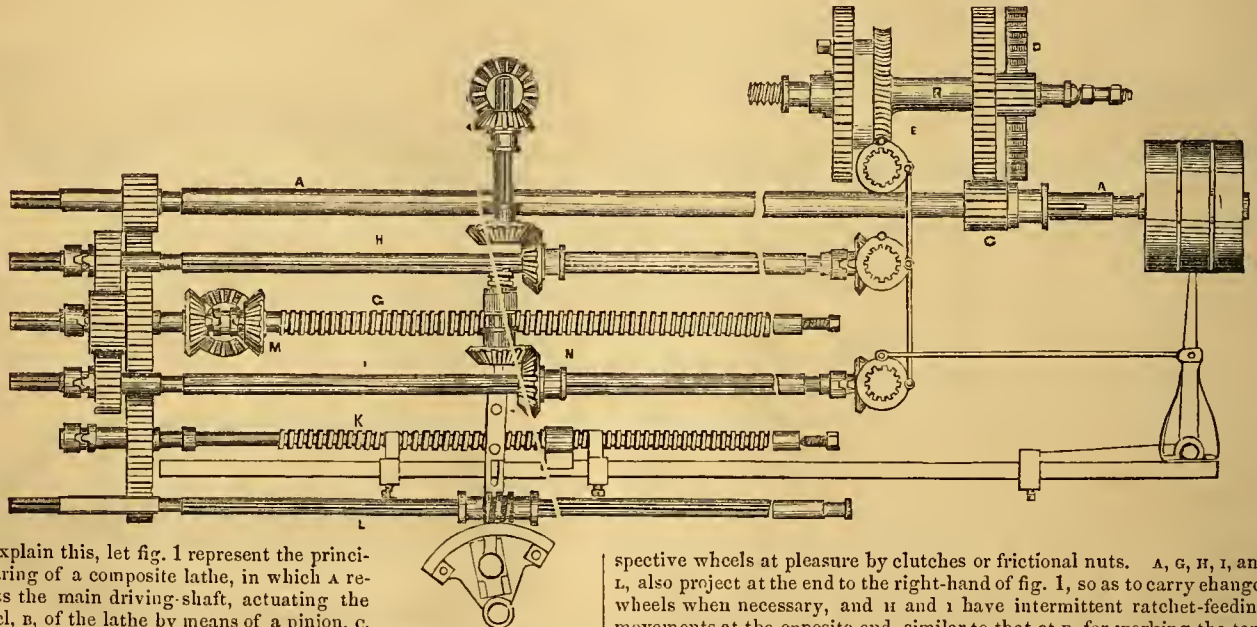

To explain this, let fig. 1 represent the principal gearing of a composite lathe, in which A represents the main driving-shaft, actuating the mandrel, B, of the lathe by means of a pinion, C, which can be slid out of gear by a clutch; D, back gearing for slow speed, as usual; E, screw-wheel and tangent-screw, with intermittent ratchet-motion feeding in either direction; G, guide-screw; H, grooved shaft for actuating the transverse slide of the slide-rest by intermediate gearing; I, the same, for moving the vertical slide; K, reversing-screw, corresponding to the pitch of the guide-screw; L, grooved shaft, in connection with the differential or barrelling motion, which is attached to the vertical slide, and consists of a segmental screw-wheel, embracing a motion of about 60°, gearing with a tangent-screw on the shaft, L. The segment has a radial slot, in which an adjustable crank-pin is fixed, the crank-pin being attached to the bearings of the screw, which slide in dovetails, and consequently the vertical slide being thus affected by the eccentricity of the crank-pin. The shafts, A, H, and I, and screws, G and K, are connected by a system of wheels, the arrangement of which is clearly shown in the end view, fig. 2; but G, H, I, and K, may be disconnected from their re-

Fig. 2.

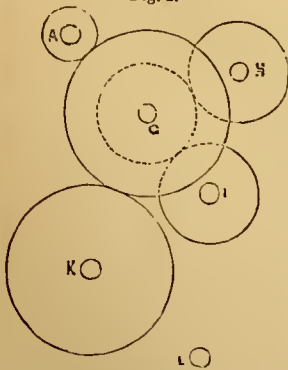

spective wheels at pleasure by clutches or frictional nuts. A, G, H, I, and L, also project at the end to the right-hand of fig. 1, so as to carry change-wheels when necessary, and H and I have intermittent ratchet-feeding movements at the opposite end, similar to that at E, for working the tangent-screw. All these are worked by the reversing bar in connection with the screw, K. An ordinary reversing movement, M, is interposed between the guide-screw, E, and its driving-wheel, for reversing the motion in sliding and screw-cutting. When the lathe is used for surfacing, this reversing motion is better applied on the driving-shaft, A. Hand adjustments, not shown in the figure, are applied to the boxes of the guide-screw, G, and of the screws of the vertical and transverse slides of the slide-rest. A composite lathe thus geared may be applied to all the ordinary descriptions of work. For sliding, boring, and screw-cutting, the mandrel is worked by the pinion, C, whilst change-wheels connect A with G. The height of the tool for turning is conveniently adjusted by the vertical slide of the slide-rest. Suppose it is desired to stop the lathe at any particular point when the attendant is absent, the screw, K, is put in gear by its clutch, and by means of the detent stop-movement, which we explained in our former description, it stops the lathe at the precise point, by throwing the belt off the fast pulley on the end of A, which travels with considerable rapidity. If it be required to turn a long cone of greater taper than can conveniently be done by traversing the following headstock, the cutting-tool is set over the work by raising the vertical slide by its hand adjustment, whilst G and I are also connected by change-wheels, so that the slide rises or falls with the cut. If a connecting-rod is to be barrellled, the crank-pin of the differential apparatus is adjusted for eccentricity to suit the rise of the sweep, and I is connected with G by the change-wheels, to spread the arc over the required length. The barrelling may be used in conjunction with the taper ad-

spective wheels at pleasure by clutches or frictional nuts. A, G, H, I, and L, also project at the end to the right-hand of fig. 1, so as to carry change-wheels when necessary, and H and I have intermittent ratchet-feeding movements at the opposite end, similar to that at E, for working the tangent-screw. All these are worked by the reversing bar in connection with the screw, K. An ordinary reversing movement, M, is interposed between the guide-screw, E, and its driving-wheel, for reversing the motion in sliding and screw-cutting. When the lathe is used for surfacing, this reversing motion is better applied on the driving-shaft, A. Hand adjustments, not shown in the figure, are applied to the boxes of the guide-screw, G, and of the screws of the vertical and transverse slides of the slide-rest. A composite lathe thus geared may be applied to all the ordinary descriptions of work. For sliding, boring, and screw-cutting, the mandrel is worked by the pinion, C, whilst change-wheels connect A with G. The height of the tool for turning is conveniently adjusted by the vertical slide of the slide-rest. Suppose it is desired to stop the lathe at any particular point when the attendant is absent, the screw, K, is put in gear by its clutch, and by means of the detent stop-movement, which we explained in our former description, it stops the lathe at the precise point, by throwing the belt off the fast pulley on the end of A, which travels with considerable rapidity. If it be required to turn a long cone of greater taper than can conveniently be done by traversing the following headstock, the cutting-tool is set over the work by raising the vertical slide by its hand adjustment, whilst G and I are also connected by change-wheels, so that the slide rises or falls with the cut. If a connecting-rod is to be barrellled, the crank-pin of the differential apparatus is adjusted for eccentricity to suit the rise of the sweep, and I is connected with G by the change-wheels, to spread the arc over the required length. The barrelling may be used in conjunction with the taper ad-

justments, as will be evident to the practical mechanic. The same parts apply equally to rectilinear cutting, whether parallel or taper, in all directions of the cube, and for harrelling in a vertical plane, the pinion, c, being disconnected with the mandrel, and the feed being applied by the intermittent ratchet motions. For cutting the hollows of connecting-rods, &c., an intermittent revolving motion is given to the tool by a tangent-screw movement as usual, but, in addition, applying to cranks and levers held on the face chuck; or, instead of the latter movement, the work may be set eccentrally, the hollows being then worked by the tangent-screw movement in connection with the mandrel.

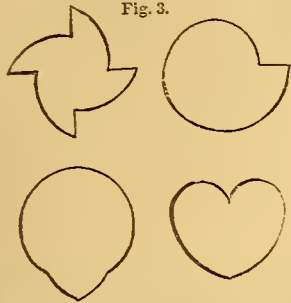

Fig. 3.



Fig. 4.

Edge-cams, snails, volutes, of spiral curvature, with any number of rises, or compounds of circular and spiral arcs, of which fig. 3 gives examples, may be accurately shaped or planed on the edges by connecting the tangent-screw with the transverse slide of the slide-rest during the reciprocating action of the cutting-tool, by means of change-wheels. To do this in the present tool, the ratchet-feed movements of ϵ and ι are put in gear, ι being prevented from moving the vertical slide by sliding

space, ν c, or sine of the angle, whilst the other slide traverses the cosine, λ b. To apply this practically, any two of the slides, actuated by ϵ , η , and ι , are connected by the proportionate wheels, whilst the third gives the cutting motion in the remaining direction of the cube. To reverse the angle, a subsidiary wheel is introduced into the pair of change-wheels.

In many cases a crank movement is convenient, in addition to the guide-screw planing movement, to work short strokes with rapidity; while the guide-screw serves for longer ranges, and also to adjust the slide-rest. The crank disc is then driven by a bevil pinion on the shaft, λ , the connecting-rod being attached to one of the bearings of the guide-screw, which is made to slide similarly to the harrelling movement.

Fig. 5 represents a composite lathe, or shaping machine, constructed on the mode of the ordinary planing machine, and designed for accurately finishing the pieces forming the framings of marine and other engines at one setting, but also applicable to a variety of other work, as it combines the powers of the lathe with the ordinary drilling, boring, planing, slotting, and shaping machines. The work is placed or traversed between the upright standards, λ λ , as in the ordinary planing machine, whilst a vertical cutting action may be given to the slide-rest and head-stock, carrying the lathe mandrel, by two connecting-rods, ν ν , actuated by crank discs beneath the bed, and balanced, if necessary. The connecting-rods are adjustable for length by means of a cross-shaft, c , actuating a screw-wheel and screw in each; ν is the tangent-screw motion, as usual, and ϵ is a slide to regulate the eccentricity of the tool during turning and planing hollows, which may be automatically fed, when requisite, by an eccentric, not shown in the figure. A screw, f , gives the cross motion, and another at the back of the slide, e , which it actuates, adjusts the mandrel in a vertical plane. By the diagonal principle we described, the octagonal recesses, or seats, for plummer-block brasses, and other angular work, may be executed with precision.

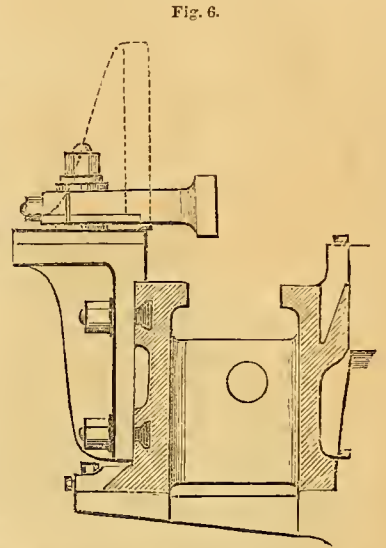

Fig. 6.

Fig. 6 represents a convenient form of head. The head-chuck applies to the side, as used for holding plummer blocks, whilst their soles are planed. A second chuck (dotted) may be superposed for fixing work vertically; and a slide may be added to draw up the work, which may then project between the bearers of the bed. For long works, a bed-chuck is used at each end. Levers, also, may be passed between the hed, by means of a diametric slide on the face-chuck, when requisite.

The arrangements of these tools may be varied to suit any kind of work, and according to the judgment of the maker.

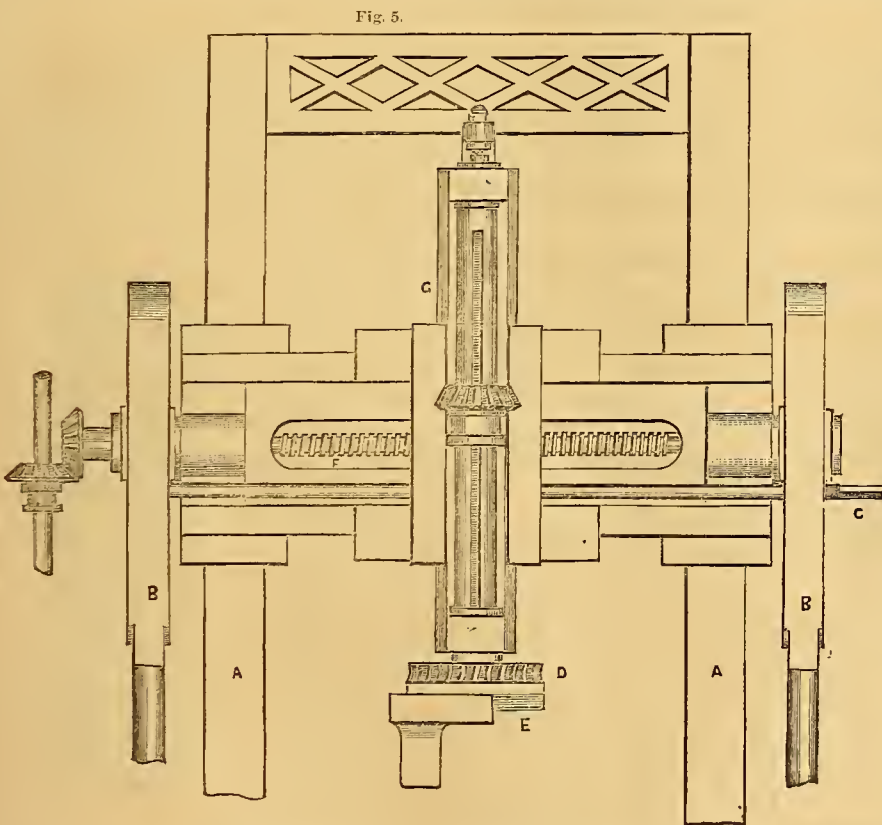

Fig. 5.

the pinion, κ , out of gear by means of an eccentric, whilst ι and η are connected by change-wheels. In the same way, face-cams and other forms may be shaped by varying the connections.

Angular and diagonal work in any position may also be worked in this lathe, without tilting the tool, by means of the same set of change-wheels. To explain this, we may observe that any angle, such as ν λ c , fig. 4, may be produced, by setting one of the slides to move through the

In a future number, we shall give tables of the settings for the various motions for workshop use. The details which we have already given, obviously furnish the elements for a most extensive range of modifications of constructive mechanism; and we think they may be characterised as affording, at least, the germs of many conveniences long wanted by the practical mechanic, as well as others, to which these aids will naturally lead him.

SUSPENSION BRIDGE OVER THE CLYDE AT GLASGOW.

Fig. 1.

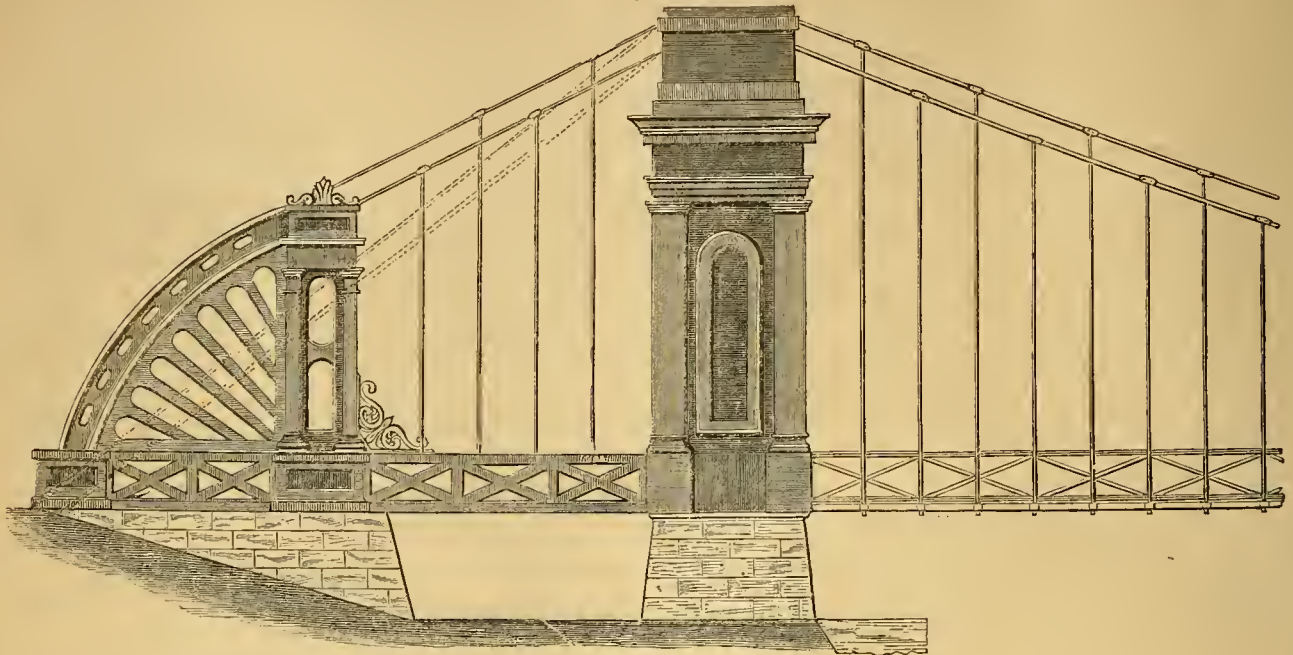

5 3/8 inch = 10 feet.

The unfortunate and costly failure of the chain bridge, which was some time ago partially erected, as a means of communication for foot passengers between the leading thoroughfare—Portland Street, on the southern side of the Clyde, and the main body of Glasgow, on the north—is now matter of engineering history. The causes of failure, proximate and remote, may be stated under two heads—primarily, an Admiralty regulation; secondarily, defective construction. The Admiralty commissioners sternly decided that the bridge should be of a single span; and hence, as the lines of streets, running parallel with the river on each side, left very little available space, it was necessary, in the absence of any other plan to obviate the difficulty, to bring the chains down from the tops of the towers at very unequal angles. Then, again, instead of good hewn masonry, the contractor gave his towers a fair exterior, but filled them up with a marrow of loose rubble—so that, when the chains were carried across, and additionally weighted with the iron girders for the roadway, the towers at once gave unequivocal signs of failure. The stones of which the towers were built crushed away at the joints on the

Fig. 2.



sides next the river, where the chains passed off at a moderate angle, compared with that on the landward sides. The works were then stopped, demolished, and commenced again *de novo*, under the superintendence of Mr. Leslie of Edinburgh, who appears to have assumed that the requirements of the case were to be fully met by a mere strengthening of the original design. During the agitation of the question as to rebuilding, Messrs. Bell & Miller, of Glasgow, proposed to rectify the matter in a more effectual manner, by assimilating the angles of the chains on the two sides of the piers; and although their plan has not been adopted, we have engraved it as a good illustration of what may be done in cases of similar difficulty.

The reduction of this angle, by carrying the chains to the apex of the quadrant framework. This framework is carried on a strong foundation, extended towards the street side, and the chains, leaving the tower at the same angle on each side, are carried down over the standard and into the ground, to the anchoring plates beneath the surface. The objectionable cross strain is thus entirely removed from the tower, as it is carried by the quadrants right into the foundations. The addition of these quadrants to solid-built towers would furnish ample strength; but to make sure on this head, the plan given in fig. 3 might be adopted. This would take a part of the strain from the masonry above the roadway, and transfer it to the solid work beneath, through the iron columns built in the masonry, and resting on a transverse girder, stretching across the pier, at the level of the roadway. The tops of these columns are connected by another girder, to take off the strain from the arch, and over this girder the chain saddles are fixed.

This plan would undoubtedly have rendered the work quite secure; but we should still have preferred the plan of oscillating pillars, suggested to us some time ago by Mr. Stelilin, a young Swiss engineer.* This plan, which was mentioned to us before the Portland Street bridge was at all discussed, consists in the so arranging the supporting pillars of the chains, that they may oscillate on bottom centres. Each pillar is composed of a pair of cast-iron side standards, connected transversely by an arched cross-beam, so as to form an open frame. The bases of the standards are made with an eye, so that they may be keyed upon a single horizontal shaft, working in two inside and two outside bearings, just beneath the ground level. The suspending chains are simply jointed to bolts on the tops of the standards. Thus, as the pillars can oscillate freely on their bottom centres, the tensional strain is at once conducted to the ground, and unequal chain angles have little or no objectionable tendency. Such a bridge would have a remarkably light and graceful appearance, whilst the freedom of action in the pillars would insure security, so long as the actual tensional strength of the materials would endure.

Fig. 3.

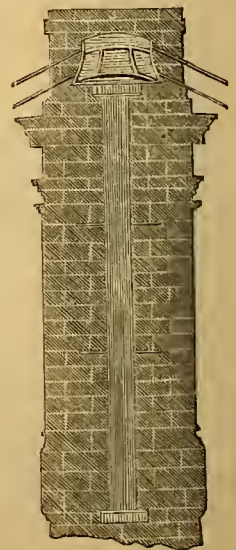

* See illustrated description, p. 108, Vol. II., P. M. Journal.

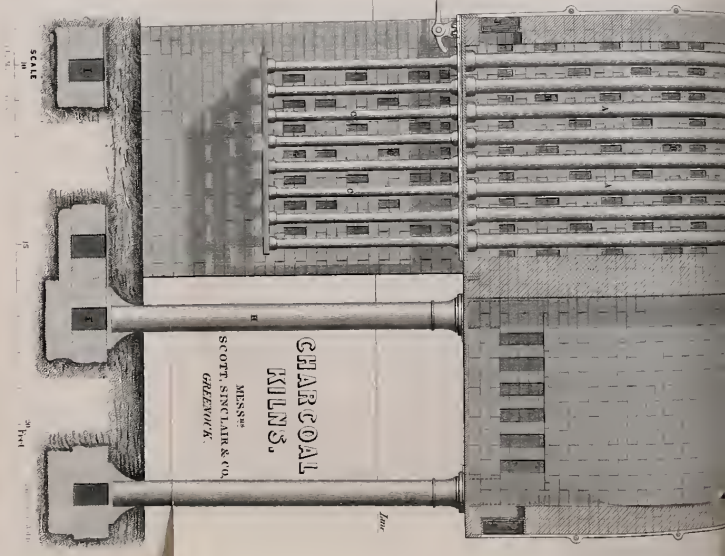
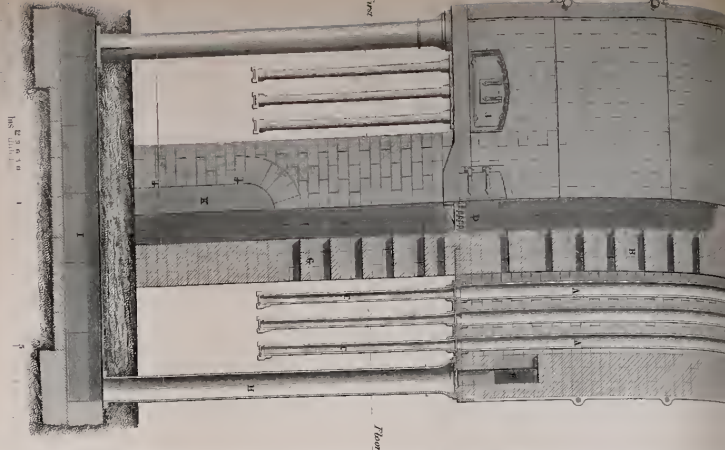

**CHARCOAL
KILNS.**

MESSRS
SCOTT, SINCLAIR & CO.
GLENNYORK.

1st 1/2"

SCALE

15'

30'

1/2"

First

Floor

Last



First

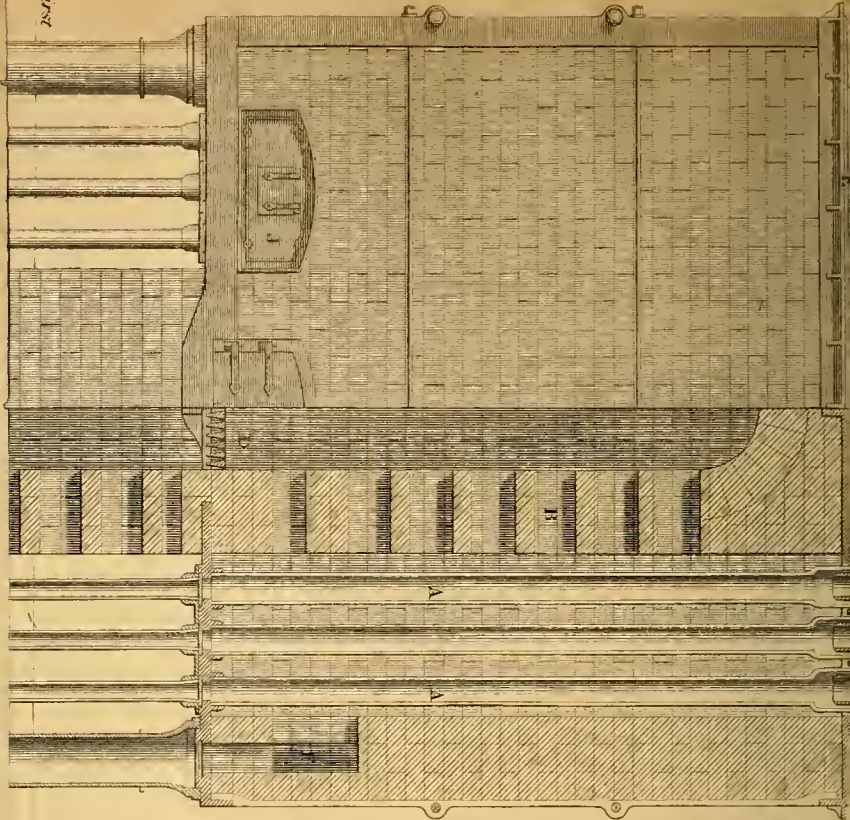

Floor

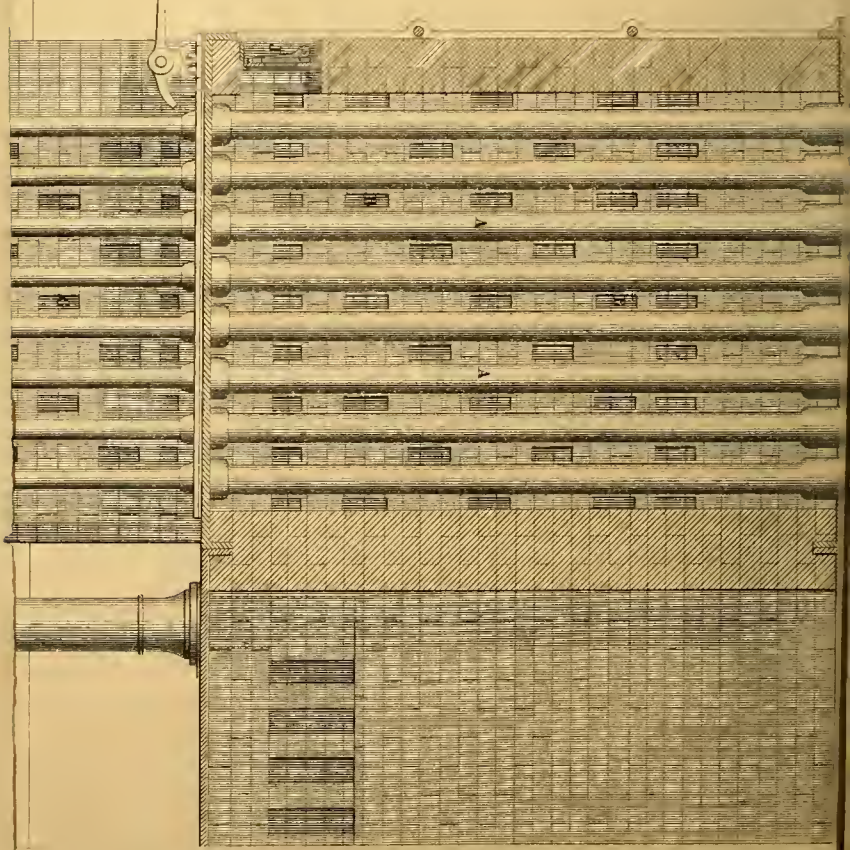

CHAR COAL KILNS.

MESSRS SCOTT, SINCLAIR & CO. GREENOCK.

Fig. 1.

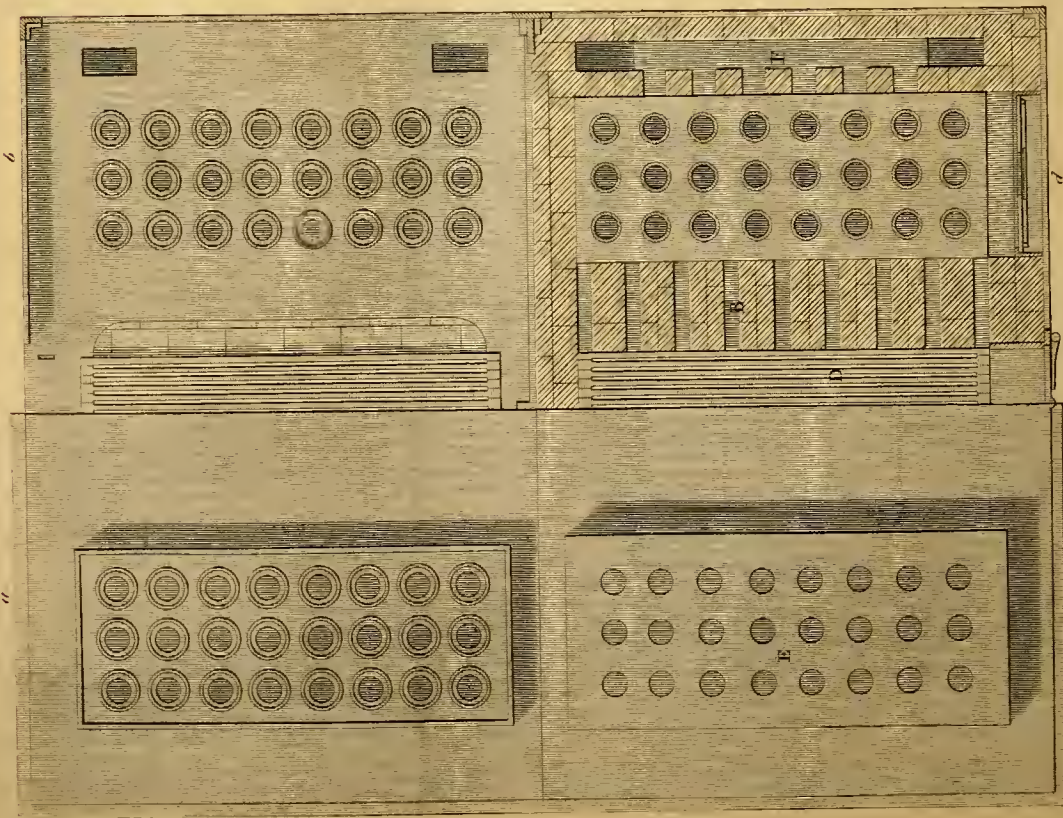
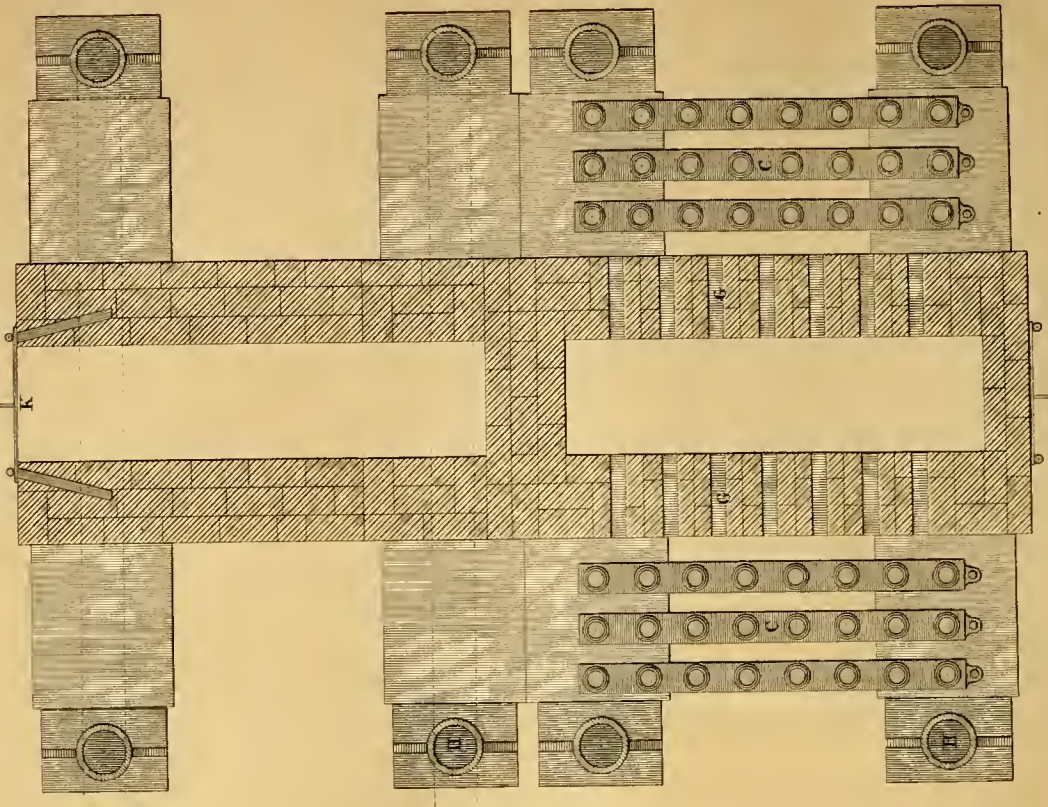
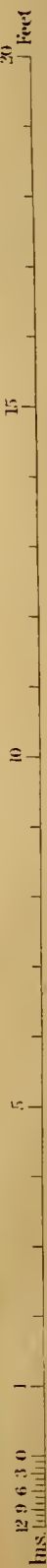

Fig. 2.



SCALE



CHAPELLE'S DRYING APPARATUS.

This invention, patented in this country by Mr. J. H. Johnson, on behalf of M. Chapelle, a French engineer, consists of an arrangement of hollow rotatory cylinders, to the interior of which, furnace heat is supplied by a revolving joint at one end, whilst a jet of water is similarly led in at the other, for the purpose of diffusing and equalizing the heat. Our engraving represents a longitudinal section of one of these cylinders in working order. The cylinder, *a*, is of cast-iron, having end discs, *b*, screwed on to close it up. These discs have hollow bearings or central trunnions cast upon them, and fitted to revolve in brasses carried by the standards, *c*. To the extremity of one of these trunnions is attached the bent pipe, *d*, which opens into the dome, *e*, of the furnace beneath, which is fitted with fire-bars, *f*, and a door, *g*. This furnace supplies the heat required for drying. Two valves, or dampers, *h*, *h'*, are fitted into the pipe, *d*, so that the flame may be either directed into the cylinder, *a*, or through the chimney, *i*. When the apparatus is to be used, the valve, *h*, is opened, and the damper, *h'*, closed, so that the whole of the flame and heat may pass through the cylinder. The extremity of the other trunnion is attached to the pipe, *j*, which is similarly fitted with a valve, *k*, to regulate the passage of flame and gas into the flue, *l*, beneath, to a second cylinder arranged like the first. A small tube, *m*, is supported in the interior of this trunnion, and serves to supply the interior of the cylinder with a small stream of water. This may be effected either by having a reservoir placed above the apparatus, or by a pipe, *x*, outside the trunnion, in connection with a reservoir or ordinary cistern. By means of a stop-cock, or plug, *o*, screwed into the copper junction-piece, *p*, which unites the tube, *m*, with the pipe, *x*, the supply of water may be regulated or stopped when necessary; or, in place of water, a jet of steam may

other; and the web of paper, as fast as it is produced, is passed over the combined cylinders, commencing with the last, or least heated one, and thence passing to the rest, which gradually increase in heat, until the first one heated directly from the furnace is arrived at. When applied for other purposes, the manufacturer will readily see what variations are necessary.

CHARCOAL KILNS AND VACUUM SUGAR PANS.

By MESSRS. SCOTT, SINCLAIR, & Co., Greenock.

(Illustrated by Plates 126-7-8.)

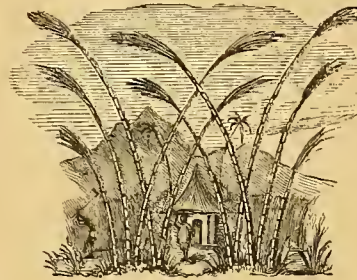

ITHIN the porous woody network of cells, in the gigantic grass, *Saccharum officinarum*, or sugar-cane, lies, well shielded and concealed, a watery fluid, which is the nucleus of what may reasonably be termed one of the most necessary luxuries of human existence. This enormous "grass" is a perennial, resembling an immense reed, throwing up a stem of from one to two inches in diameter, and reaching

the towering height of 16 or 17 feet, the whole length of which is made up of a succession of knots or joints, surmounted by a flower branch as an apex. This plant is divisible into three distinct kinds—the *Creole*, indigenous to India, but now transplanted into Sicily, the Canary Islands, the Antilles, and South America; the *Batavian*, or striped species, a native of Java, and principally used for the manufacture of rum; and the *Oahuite*, now spread over the West Indies and South America. It is the saccharine juice of this plant, expressed from the solid stems by passing between powerful rollers, that furnishes the solid crystal matter, now of universal use as a sweetener of a large proportion of our food. The juice is obtained by cutting down the stems, and carrying them at once to the sugar-mill, usually a simple but massive combination of three squeezing rollers. The negro attendants pass the canes evenly through these rollers, and the expressed juice is caught in a retaining cistern, whilst the stems, left nearly dry by the process, become what is technically

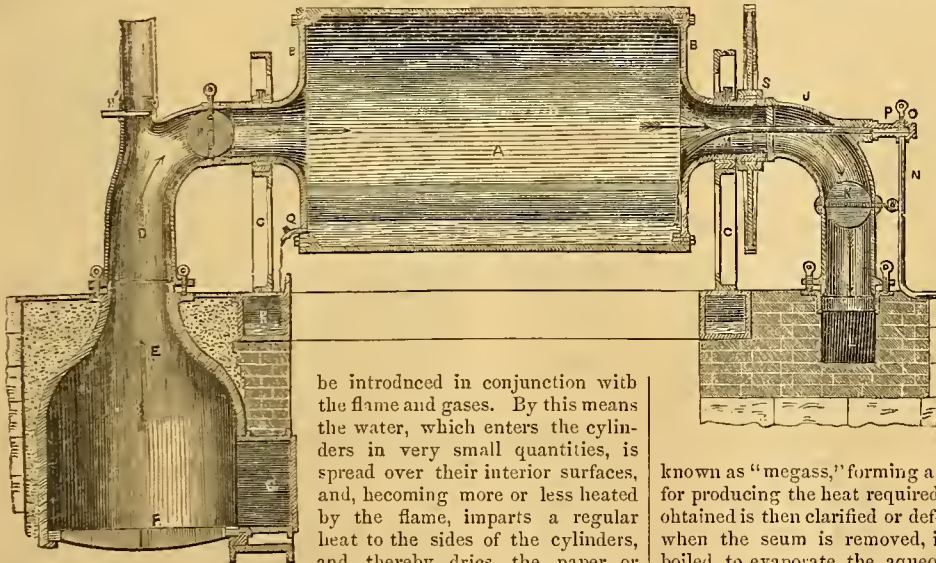

be introduced in conjunction with the flame and gases. By this means the water, which enters the cylinders in very small quantities, is spread over their interior surfaces, and, becoming more or less heated by the flame, imparts a regular heat to the sides of the cylinders, and thereby dries the paper or

other fabric passed over it, regularly and evenly over the whole of its surface. The water is allowed to escape, at each revolution of the cylinder, by the pipe, *q*, which is fitted with a stop-cock, to be opened either by hand or by the movement of the cylinder itself, which, in its revolution, may be made to bring the handle of the cock in contact with a fixed motion, and so allow the water to escape into the cast-iron receiver, *n*, which serves also as a base plate, to which the cylinder supports are bolted. A rotatory movement is given to the cylinder by a pulley, or spur-wheel, *s*, keyed on to the trunnions. To prevent the trunnions from being overheated, a stream of water and oil is allowed to pass over them. Instead of employing a furnace and heating the cylinder by direct contact with the flame, hot air may be applied externally; for this purpose it will be necessary to employ a heater, consisting of the stove, *e*, and a number of pipes similar to the one shown at *d*, through which pipes the flame must pass on its way to the chimney; and as their external surfaces will be well heated, the air, which will have acquired an elevated temperature, will enter the cylinders, and mix with the jet of water, in a manner similar to the flame and gases before described.

What we have described refers to one arrangement of heating cylinder only; but in the application of the system to extensive factories, it is intended to fit up a series of such cylinders, the heat being passed from one to the other throughout the range. If paper is to be dried in this way, the cylinders are disposed side by side, and parallel to each

known as "megass," forming a clear, sharp, burning fuel, admirably suited for producing the heat required in the sugar manufacture. The juice so obtained is then clarified or defecated, by boiling with milk of lime; and when the seum is removed, it is filtered, and the cleansed syrup is boiled, to evaporate the aqueous particles, and leave the solid raw sugar behind. This process produces only crude raw sugar; and it is with a portion of the apparatus for the refining and whitening of this product, that we have now to concern ourselves.

Raw or muscovado sugar, as imported into this country, is contaminated with many impurities, and, after some preliminary treatment, it is passed in a state of solution through bag filters, charged with deep strata of bone-black, or animal charcoal. This finally cleanses the sugar, and the syrup is reduced to the granulating or crystallizing pitch, by evaporation in Howard's well-known vacuum pan. For every 100 tons of manufactured sugar, about five tons of animal charcoal are consumed; and as the refining material is an expensive item in the sugar manufacture, strict attention must be paid to the economies of its employment. With this view, the spent charcoal, holding within it the gross impurities of which it has deprived the syrup, is reburied, to carry off such impurities, and fit it for subsequent filtering use. It is this reburning process which Messrs. Scott, Sinclair, & Co. have so successfully improved, in their new arrangement of charcoal kilns or retorts, delineated in our plates 126-7-8.

The drawings, by which we illustrate these improvements, were taken from the actual kilns erected at the refining works of Messrs. Hall and Boyd, of London. In this arrangement, provision is made for the cooling of the charcoal by a continuous process, without the use of water, so that the charging and discharging of the material goes on

uniformly and continuously, whilst the quality of the reburned charcoal is greatly improved.

Fig. 1, on plate 126, is a half elevation and half-longitudinal section of the kiln. Fig. 2 is a transverse sectional elevation of the hot-air chamber—one-half showing the charcoal pipes, with the coolers, and the hot and cold air flues, whilst the other half represents the opposite side of the hot-air chamber, with the pipes removed, and showing only the exhaust flues and supporting columns. Fig. 1, on plate 127, is a corresponding plan of the apparatus, partially in horizontal section; and fig. 2 is a complete horizontal section at a lower line.

The kiln is arranged with a series of vertical charring tubes, *a*, surrounded by fire or hot-air flues, *b*. These tubes are the charring retorts, into which the charcoal is put to be burned. Immediately beneath these retorts is a second set, *c*, of smaller bore, which act as the coolers. These are also set vertically, and the axis of each is coincident with that of a corresponding retort. The further details are pretty evident from the plates. In the plan, fig. 1, of plate 127, the division, *a*, represents the top plate of the kiln, with the cover removed, and exposing the guard plate. The next division, *b*, is a plan of the bottom plate of the kiln, with the brickwork taken off it. Division *c*, is the top plate with the cover on; and the fourth, *d*, is a horizontal section, showing the fire-bars, hot-air and exhaust flues, flue door, and retorts. Fig. 2, on the same plate, is a horizontal section through the ashpit, the front portion showing the coolers, cold air flues, and the columns for supporting the kiln; the back part, showing the ashpit door and the columns, which, besides supporting the kiln, serve also to convey the smoke to the chimney through the dotted-line flues. The retort furnace is at *D*; *E* is the cover plate; *F* are the exhaust flues; *G*, the cold-air flues; *H*, the columns; and *I*, the main flues; *J*, the flue door, with a small central door in it for examining the state of the retorts when in action; at *K* is the ashpit door, which is kept shut, so that all the cold air for supplying the furnace must pass through the coolers and cold-air flues, so as to cool the charcoal in the coolers, whilst it is burning in the retorts.

When a charge has been burned, the attendant opens a slide in the bottom of each retort, and so discharges about one-third of the charcoal in it down into the cooling tube below. When this is done, the cooling tube being filled, or nearly so, the tube is shut up, and its contents are then rapidly cooled by an external circulation of cold air along the passages to which we have referred. The upper portion of the partially emptied retort then receives a fresh supply of the unburned charcoal, to fill up the vacuum in it, and thus the operation goes regularly on throughout the whole series in the kiln. A good current is always kept up round the cooler tubes, and the air, thus partially heated, is thence passed up to the retort furnaces above.

Fig. 1, on plate 128, is a longitudinal section of part of a sugarhouse, showing a front view of a vacuum pan, heater, and pump. Fig. 2 is a transverse section of the house, representing a side elevation of the same parts, with the addition of the condenser. The vacuum pan, *A*, rests on an upper floor of the building, as shown by the horizontal dotted lines—the two lower lines in each of which cases, represent the upper and lower edges of the beams carrying the joists. The pan is formed in the usual manner, with an external steam-chamber heated by steam led along the pipe, *n*. At *c* is a manhole door, the cover of which is ground steam-tight on its seat; a conical plug, *d*, being fitted on for the admission of air when running off. A swan-necked pipe, *e*, forms the connection between the pan and the condenser, *f*; a branch, *g*, being made on its lower side for conveying the sugar to the safe, *u*, in case of excessive ebullition. The condenser, *f*, has an enlarged chamber, *i*, in the interior of which is the rose communicating with the cold-water pipe, *j*, a manhole door being fitted on at this part for access to the rose. To govern the connection between the vacuum pump, *k*, and the pan, a screw stop-valve is fitted at *l*, on the top of the pipe, *m*, leading to the pump beneath. This pump, which has a foot-valve, *x*, hot well, *o*, and discharge pipe, *r*, is worked by the continuously revolving shaft, *q*, and crank, *n*. The main steam-pipe, taking steam from the boiler to the vacuum pan, is at *s*, a screw stop-valve being fitted at *t*, whence a branch passes to the worm inside the pan. The direct steam is supplied to the pan by the small branch, *v*; and at *v* is the barometer; *w*, the thermometer; and *x*, the "proof-stick." The pan is charged with the liquor or syrup by the cock, *y*, on the top; at *z* is the pipe for carrying off the water of condensation from the steam space surrounding the pan; and the smaller pipe, *a*, performs the same office for the internal worm. The discharging is effected by the slide-valve, *b*, worked by the lever, *c*. Beneath is the "heater," *d*, heated by a steam-jacket, like the vacuum pan, by the pipe, *e*, the water of condensation being led off by the pipe, *f*. The heater is emptied by the cock, *g*, beneath which is the basin and stand, *h*. At *i* is the lens through which the boiling action is watched by the operator.

The limits of our present paper obviously do not permit of our going into a minute detail of the process of refining; but the foregoing description will be sufficient to show the latest improvements upon this very interesting branch of industry.

CHAPLIN'S DUPLEX PRESSURE FAN.

The common fan has hitherto been narrowly limited in its practical application as a blower, by its great deficiencies as a pressure producer. For soft, diffused blasts, or for the mere exhausting of aeriform bodies, its simplicity has insured for it an almost universal adoption. But for such great pressures as the blast furnace requires, something more is necessary—more even than a dangerously high rate of working can by any possibility afford. It is

this defect which Mr. Chaplin seeks to remedy. He combines two fans in one, and with a single spindle, driven by a central band-pulley, he takes in air by one case, and conveys it in its compressed condition into the second, whence it is finally discharged at a much higher pressure than a single fan can give; whilst he encounters no difficulty in his speed of running. Fig. 1 of our engravings is a vertical section of the fan, and fig. 2 is a plan complete. The sole plate, *A*, with which is cast the underneath air-passage, *B*, forming the communication between the two fan cases, *C*, *D*, carries the entire apparatus. Each fan case is cast with one side on, and bolted down upon the sole-plate; whilst the inner sides, *E*, are loose and separately bolted on. The spindle, driven from the central pulley, *F*, is supported on one side by a bearing, *G*, cast on the inside of the vertical portion of the passage, *B*,—this passage being in one piece with the side-plate of that fan. The bearing, *H*, for the opposite end of the spindle is on a separate cross-piece, attached across the central induction aperture.

In this particular example, three blades are used in each fan, the arms being forged in one piece and the blades riveted to them. The arrows show the direction of the currents. The air is first taken into the larger fan, *C*, in the usual manner; and in its partially compressed state, it is discharged tangentially from the tips of the blades, and conducted along the inclined passage, *B*, as shown in dotted lines in fig. 2.

Fig. 1.

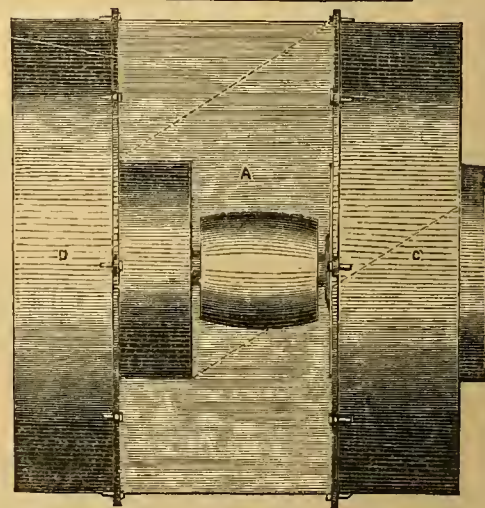
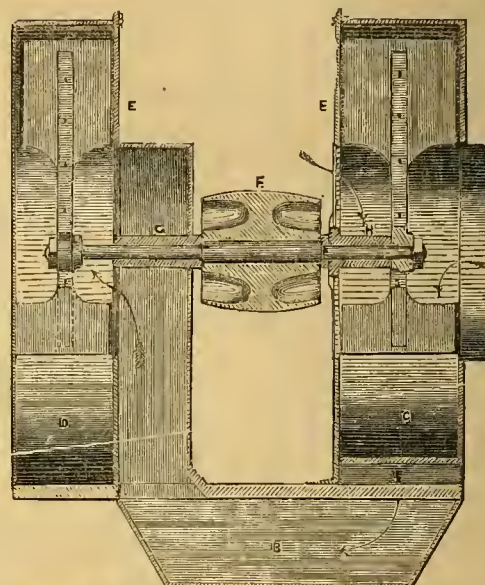

Fig. 2.

MESSES SCOTT, SINCLAIR & CO. GREENOCK.

Fig 1.

Third Floor

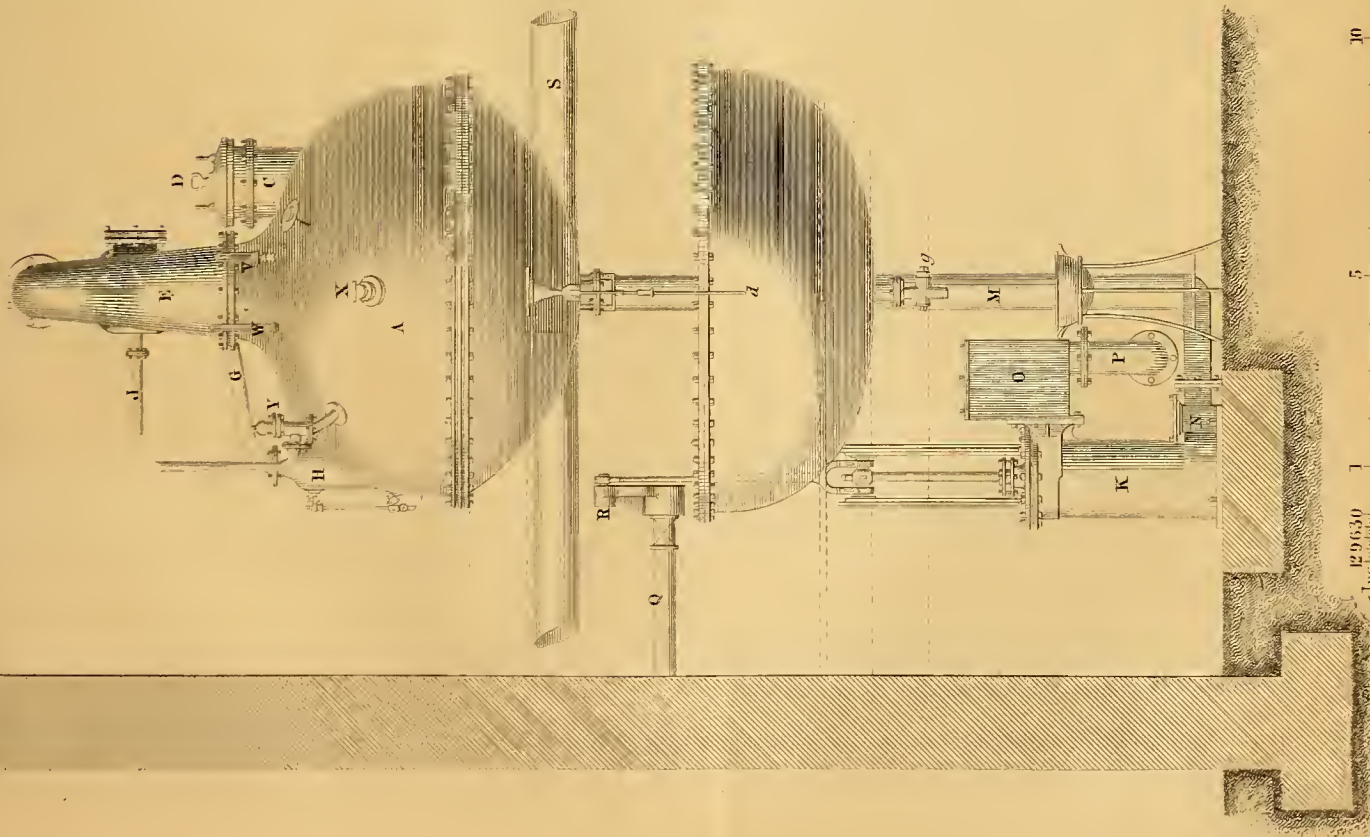
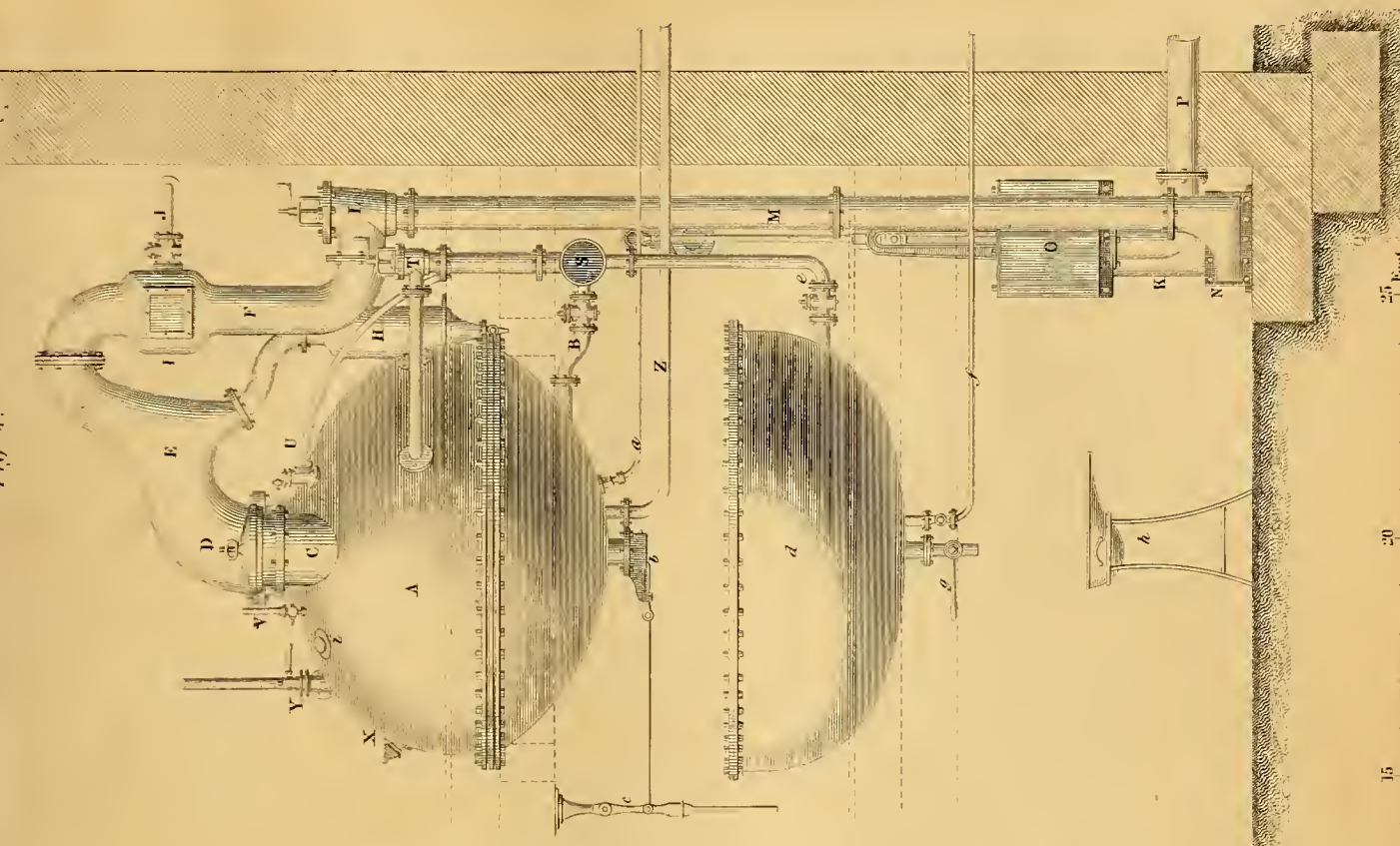

Fig 2.

Second Floor

First Floor



129630

1/2 in

SCALE

10

5

1

1

25

feet

This passage conveys the air into the inner central side opening in the smaller fan, *D*, from the case of which it is finally discharged by a tangential passage in the usual way. By this plan, the duplex action affords a high degree of pressure; amounting—as deduced from the inventor's tests—to very nearly double the pressure attainable by a common fan, running at the same circumferential rate.

OUTLINES OF GEOLOGY.

VI.

SECONDARY EPOCH (CONCLUDED).

CRETACEOUS SYSTEM.—In this system we find a return to deep-sea formations, indicating a great subsidence of land subsequent to the formation of the Wealden. It extends over a large part of the south-eastern portion of England, commencing on the outside edge of the Oolitic system. Its most northern point in England is on the east coast, between Flamborough Head and Scarborough. Thence, proceeding south, it lies between the oolite on the west, and the marshy lands of Yorkshire and Lincolnshire, till the Wash is nearly reached, having, during this part of its course, a south-easterly direction. Across the Wash, it commences again at the north-eastern point of Norfolk, spreading out along the northern coast of that county. It now takes a south-westerly course, being bounded on the west by the oolite, and on the east by tertiary strata, which occupy the whole coast-line of this part of England. Devizes stands nearly in the middle of the land, which is there much narrower than in its upper part. South of Devizes, the beds widen out so as to occupy a large area in Wiltshire and Hampshire. Salisbury Plain is part of this area. It is not a plain, in the ordinary sense of the word, but a high undulating down, or moor, stretching about twenty-five miles from east to west, and fifteen miles from north to south. Its greatest elevation is 775 feet. From this main trunk, three branches diverge—one almost due east from Basingstoke, by Guildford, Reigate, and Maidstone, to the coast, which it occupies from a point south of Dover to Margate. Here are seen the famous chalk cliffs, from which is supposed to be derived the name *Albion*. The second limb begins about Winchester, and proceeds in a direct line to Beachey Head. It is between these two limbs, the elevated parts of which are known as the North and South Downs, that the Wealden system is situated. The third limb is much shorter than the others. It proceeds in a kind of zig-zag from Salisbury to the coast of Dorsetshire. The Hampshire basin, which forms part of the deposits of the next epoch, is situated between the second and third limbs; and another large portion of the deposits of the same epoch (to which the London basin belongs) is situated between the North Downs and the main trunk.

The two chief members of the Cretaceous system—namely, the green sands and the chalk—are very different from each other, both in mineral composition and in physical character. The chalk forms ranges of hills, with a peculiarly soft-flowing outline, for the most part little wooded, but affording excellent sheep pasture. The green sand is commonly spread out at the foot in a narrow band, in a few cases rising into round hills, which are as high, or higher, than the chalk, but generally forming much lower tracks, covered with heath and brake. Its *outcrop* (the line where it comes out from under the upper series) is in some places several miles distant from the base of the chalk hills, and at others near their foot. An outlying portion of the green sand occurs on the borders of Dorsetshire and Devonshire, separated from the other portions of the Cretaceous system by the oolite and lias. It there forms the range of Blackdown hills, and also caps another range—the Halidon hills—which approaches close to the granite of Dartmoor. The Blackdown hills furnish whetstones; and, what is remarkable, out of one hundred and fifty species of fossil remains which have been discovered in these beds, ninety are not known to occur elsewhere in England. The green sand consists generally of ferruginous brown or green sand, with local deposits of limestone. The Kentish limestone, or rag, is a well-known calcareous member of the series. In the upper series, the gault is the first bed. It is a stiff blue clay, sometimes used for making bricks. The lower part of the bed abounds in iron pyrites. It almost always divides the lower and upper green sand, and maintains the same mineral character throughout. At Folkstone, it forms a cliff (full of fossils) about 120 feet high, resting on the lower green sand. Above the gault occurs the upper green sand, which varies very much in thickness; in some places (the vale of Wardour, for instance) rising into a narrow ridge of from 50 to 60 feet in thickness. Proceeding northwards from this point, it gradually declines to a thickness of a few feet only. It is considerably developed at the foot of the North Downs, between Godstone and Reigate, and is there quarried for

firestone, which also occurs in some other localities. Next to the upper green sand, and immediately under the chalk, occur beds of a cretaceous argillaceous character, known as chalk-marl, sometimes coloured green by silicate of iron, or red by oxide of the same metal. Above this bed occurs the chalk, the lowest part of which is usually distinguished as being harder than the upper part, and without flints; which are abundant in the latter, as dark-coloured nodules disposed in layers. Chalk is a nearly pure carbonate of lime. The origin of the flint nodules is not clearly made out. In some cases, the siliceous matter has gathered round sponges; in others, it is composed almost entirely of the remains of microscopic animals, which, however, also occur very abundantly in the white chalk. Siliceous aggregations are not peculiar to the chalk, but occur in parts of the mountain limestone and oolite. Moreover, similar siliceous matter makes its appearance in the chalk of Ireland and the Continent in layers.

The organic remains of the Cretaceous system are numerous. Saurian reptiles continue, some new genera making their appearance. Fish also occur; of Placoids, between thirty and forty species; of Ganoids, between fifteen and twenty species; of Ctenoids, three species; and of Cycloids, ten species. This is the first appearance of the two latter groups, which have scales not enamelled. Ammonites are conspicuous in this system, measuring sometimes four feet in diameter. These curious fossils make their appearance almost in the earliest fossiliferous rocks, and continue throughout the secondary epoch, attaining their maximum of development in the chalk, and ceasing with it. Hamites, Scaphites, Baculites, and Belemnites, are other forms of cephalopodous shells which occur in the Cretaceous system. Zoophytes are abundant, and some of them nearly allied to existing deep-sea genera. Foraminifera—an order of small conchiferous molluscs, some living species of which are very destructive to timber—occur in abundance among the chalk beds. One group of shells (Rudistes) discovered in the chalk are unlike any known forms. Certain remains discovered in the chalk at Maidstone were attributed by Professor Owen to a bird which he named *Cimiliornis Diomedea*, but other investigators believe them to belong to a Pterodactyl.

In the slates of Glarus (Switzerland), attributed to the Cretaceous period, the remains of *Lithornes vulturinus*, a British eocene fossil, have been discovered. Foot-prints of birds are also common in America, in strata assigned to different parts of the secondary epoch. Chalk occurs in Ireland (Antrim) covered by basalt. No part of the system is found in Scotland.

The following is a summary of the animal creation during the whole secondary epoch, which closes with the Cretaceous period:—

MAMMALIA.—The first appearance of this the highest class of animals, occurs in the Oolitic period, where three marsupial animals have been found. No traces of the class occur in any subsequent member of the secondary epoch.

BIRDS.—No certain traces of birds in any British strata of the secondary epoch; but they occur in other countries.

REPTILES.—So numerous, and of such gigantic proportions, are the reptiles of this epoch, that it has been designated "the age of reptiles." Reptiles appear to have commenced at a time immediately preceding the secondary epoch, and with forms resembling that of the lizard. To these followed animals of the orders Chelonia (turtle, tortoise, &c.), Batrachia (frog, toad, &c.), Sauria (lizards), and Enaliosauria. The last order (of which Ichthyosauri and Plesiosauri afford the type) is not represented in the present day. The Enaliosauria terminated with the Cretaceous period, and some of the strangest forms of Sauria, such as *Megalosaurus*, *Iguanodon*, *Pterodactylus*, are seen no more, the crocodile being the representative of the order in more recent periods.

FISH.—The greater number of fossil fishes belonging to the secondary epoch are of the Placoid and Ganoid types, but at the end of that period, Ctenoid and Cycloid fishes make their appearance.

ARTICULATA.—The Tricohite form of crustacea, so abundant in the Palæozoic epoch, had become extinct before the commencement of the next epoch, giving place to other forms. The Cretaceous system is most fertile in animals of this sub-kingdom; the new creation resembling the lobster, cray, and shrimp of the present day. Some species of the class Cirrhapoda occur in the oolite.

MOLLUSCA.—With the secondary epoch commenced a new series of Cephalopoda. All the Palæozoic genera were extinct except the *Nautilus*, which comes down to the present day as a reminiscence of an ancient world. The first remains of cuttle-fish resembling existing species occur in the lias. Belemnites appear for the first time, and are very abundant. Towards the end of the epoch they become less abundant. Hamites are abundant (chiefly in the gault). Scaphites become a prominent genus. Turrilites, Baculites, and Ptychoceras, are characteristic of the latter half of the secondary epoch. But the Ammonites are the

most remarkable order of new creations. They begin, attain enormous size towards the end of the epoch, and then disappear.

Gasteropoda and Conchifera begin to take the place of the Cephalopoda and Brachiopoda, as these wane or disappear. Numerous Gasteropoda, and some of recent genera, occur in the oolitic rocks.

RANIIATA.—Of this sub-kingdom, the class Echinodermata is well represented, all the orders being those of existing seas. The order Echinida appears for the first time, and in greater abundance than in the present seas.

A few species of Nautilus are the only representatives of testaceous cephalopoda, which survive to the tertiary epoch. Brachiopoda are feebly represented in the secondary epoch as compared with the Palæozoic. Most of the characteristic genera of the latter disappear. Terebratula, Lingula, and Orbicula, and some other genera survive.

Zoophytes of this epoch are generally very different from those of the oldest epoch. They occur abundantly during the Oolitic and Cretaceous periods. Sponges and Foraminifera are abundant.

The following table shows the number of species of plants (with the families) which existed during the secondary period.

	Trias to Wealden.	Cretaceous.
Algæ,.....	3	—
Calamariæ,.....	1	—
Filices,.....	48	1
Selaginæ,.....	1	—
Zamiæ,.....	32	3
Coronariæ,.....	1	—
Principes,.....	4	—
Conifere,.....	9	2
Uncertain,.....	3	—

GEOGRAPHICAL DISTRIBUTION OF SECONDARY ROCKS.—On referring to M. Boué's map, we see that the rocks of the secondary epoch are not distributed over large areas of the earth's surface, but occur in many places in all the great continental divisions.

MECHANIC'S LIBRARY.

- Agricultural Engineering, Vol. III., 12mo., 1s. Andrews.
- Carpentry, Elementary Principles of, 4th edition, 4to., 42s. Tredgold.
- Coal-Gas, On the Manufacture of, 2d edition, 4to., 31s. 6d., cloth. Clegg.
- Chemical Phrase-Book, in English and German, 18mo., 6s. Johns.
- Chemical Field Lectures for Agriculturists, 4s. 6d., cloth. Stockhardt.
- Drawing-Book, First, folio, 7s. 6d., cloth. Hannah Bolton.
- Map-Making, Manual of, 3d edition, 12mo., 2s., cloth. A. Jamieson.
- Non-Metallic Elements, Lectures on the, foolscap Svo., 5s. 6d. Faraday.
- Scientific Dialogues, new edition, G. Walker, foolscap Svo., 6s., cloth. Joyce.

RECENT PATENTS.

FIRE-GRATES.

JOHN FINLAY, *Ironmonger, Glasgow.*—*Patent dated October 1, 1852.*

Fig. 1.

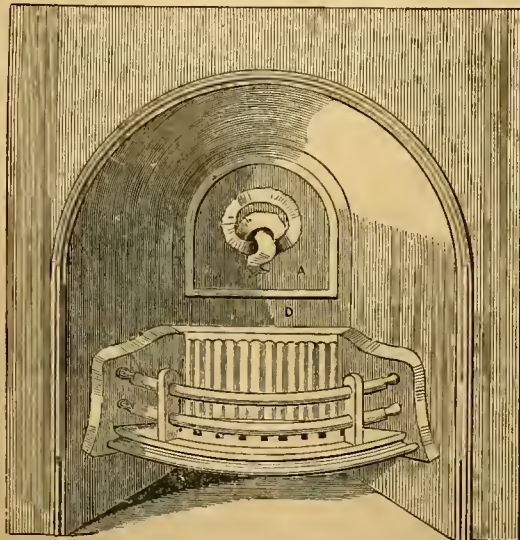

Mr. Finlay, whose sound practice in many improvements connected with lighting, heating, and ventilation, have frequently found a place in our pages, has here produced a most effective plan for the general

improvement of domestic fire-grates. The special objects which he has had in view, in the present instance, are to be thus summed up:—1st, efficiency of draught; 2d, superior radiation of heat; 3d, the accurate and easy adjustment of the regulating details for modifying the draught and the combustion of the fuel, and the prevention of smoke.

Fig. 1 is a front elevation of a domestic fire-grate, arranged to meet these requirements; fig. 2 is a transverse vertical section corresponding. In this arrangement a single overhanging draught door is formed at the back of the grate, and hinged

Fig. 2.

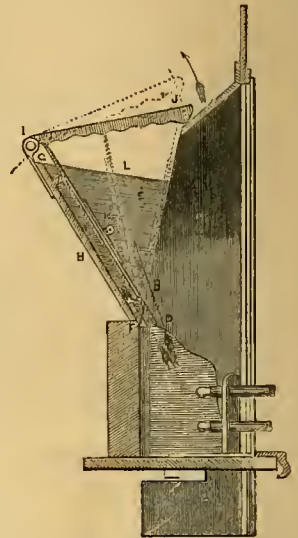

by its bottom, or near its lower edge. This door is so contrived, that when fully open, to allow of the greatest possible extent of air passage to the chimney, it inclines backwards, from its bottom joint, towards the chimney, or the wall in which the grate is placed; and when the door is fully closed, to shut off all chimney draught, its upper edge inclines forward, from its bottom joint, towards the room. This door regulates the main, or what may be termed, the front direct draught into the flue or chimney, the smoke and heated air passing off from the fire-place by the upper portion of the door. But the door is adapted as well for furnishing a means of back draught, or secondary air passage, at a lower level, by which means any thick green smoke is at once conveyed off from the level of the surface of the coals in the grate to the flue, by a short route, so as to keep the fuel clear of smoke, to aid the draught, and to prevent the chance of such thick heavy smoke getting into the apartment to be heated.

This back draught is obtained by hinging the lower edge of the door to the fixed portion of the back of the grate, at or near the level of the surface of the burning fuel, by means of a horizontal joint, or centre-pin, beyond which joint-pin the lower edge of the door is slightly prolonged, so as to form a secondary regulating door or valve. The door thus becomes a double lever, the upper side, or main portion, being arranged to close by moving forward; whilst the lower edge beneath the joint similarly closes its narrower duct or passage, by the consequent backward motion. Suitable means being provided for the escape of the dense smoke, through the lower opening, into the flue, whatever smoke so passes escapes up the chimney behind the main portion of the door; and any heated gases or air so passing, thus produce radiant heat, by acting on the door from behind. This duplex arrangement of door thus opens and closes both passages simultaneously, and any regulation of the main door correspondingly adjusts that for the lower back draught; and a means is afforded by it, of taking off the sluggish smoke at once, from a green or fresh fire, so as to give the smoke no chance of escaping into the room. The adjustment of the draught door may be effected in various ways; as, for example, by a notched catch-rod hinged to the door, and contrived to be available from the front of the door, or side of the grate—the notches, or detents, working over a fixed stop behind the grate; or, instead of this arrangement, the adjusting-rod, or lever, may be formed with an undulating edge, or with rounded notches, so that a weight hung on the end of the lever, or a spring either in the lever itself or detached, may hold the door at any determined undulation. By this plan, mere pressure on the door will adjust it either way, without attending to the lever or catch-rod; or, instead of this plan, the door may be set on a friction joint centre, adjustable to give any required degree of frictional hold, to retain the door at any angle at which it may be set. Frictional side pressure, by a spring, may also be used for the same end, so as to give a noiseless plan of adjustment, with simple and easily manageable details. The overhanging door, A, is in this case hinged at B, by a pair of side pivots, which rest in recesses in a hinge support, C, one on each side of the grate, N, being the prolongation of the door below the joint, or suspension, to form the back draught. As arranged in fig. 2, the draught door is full open, and the main draught current passes off in the direction of the arrow, E, in front of the door, to the chimney; whilst the back draught, or secondary current, passes through the smaller aperture, F, and escapes to the chimney also along the space, G, between the back of the draught door and the front of the stationary inclined hack plate, H. To the upper edge of this hack plate is fastened a hinge-piece, I, to which is loosely jointed the rod, or link, J, formed

with undulatory notches on its lower edge. This link, which acts as the detent for the door, projects forward, and rests upon the upper edge of the door, so that when the latter is drawn forward by the ornamental projection, *k*—to the position, for example, indicated by the dotted lines, *l*—its loose end bears upon the door, and retains it at the desired angle. In this way the domestic may easily adjust the door to any extent of opening, as a slight pressure in either direction will cause the upper edge of the door to slip along the detent undulations to the intended position. The dotted door, *e*, also illustrates the mode in which any change in its position, correspondingly affects the back or secondary draught aperture.

A most important effect of this arrangement of grate is, that, by the agency of the back draught, the great mass of the smoke is drawn through the incandescent fuel in the grate, in passing to the small escape-door. In other words, instead of the smoke passing up in all directions over the top of the fire, it is actually drawn off horizontally, or nearly so, and must of necessity be exposed to a large burning fuel-surface before it leaves the grate. Thus, the smoke cannot play about the fire, and be dispersed into the room by chance diffusive atmospheric currents. Indeed, it is supposed that at least one-third more smoke is actually consumed in this grate than in the common one.

CANDLESTICKS AND LAMPS.

G. S. OGILVIE, *Stapleton, Somerset*.—*Patent dated Nov. 9, 1852.*

Mr. Ogilvie's invention consists of a simple application of metal or india-rubber springs to portable lamps and candlesticks, for retaining the loose accessories thereof—such as the snuffers and extinguisher—in their assigned positions. Our engraving represents one of the inventor's

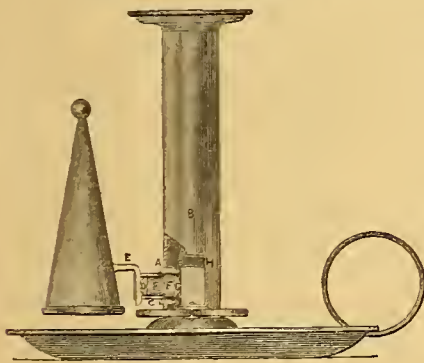

candlesticks in side elevation. At *A* is a short metal socket, soldered to the lower portion of the cylindrical stem, *b*, of the candlestick; and to this socket is attached the short tube, *c*, containing a metal catch, *n*, which has a slightly convex surface, fitting into a corresponding indentation in the supporting shank, *e*, of the extinguisher. Two small discs or plugs, *f*, of india-rubber, are fitted within the

socket, *a*, and tube, *c*, and serve as the spring to nip, and thus hold the extinguisher shank in the position shown in the figure. A small button or disc, *c*, having a rounded surface, is fitted loosely into the inner extremity of the fixed socket, *a*, and projecting slightly beyond the end of it; and when the tube, *c*, is fastened into its socket, the elastic plugs inside exert a pressure against the button, *c*, and catch, *n*, simultaneously, tending to force each of them outwards. On inserting the snuffers into their retaining slot in the base of the candlestick stem, the projecting button, *c*, presses against the side of the box portion of the snuffers, and thus nips them, so as to prevent their falling out, although readily yielding to permit of their removal when necessary. The extinguisher is held in a somewhat similar manner—the hollow in the shank, *e*, fitting on to the convex surface of the catch, *n*. Mr. Ogilvie has explained several varieties of catches on this general principle, all of which are useful ingenuities.

IRONSTONE BRICKS AND POTTERY.

W. G. ELLIOTT, *Blisworth*.—*Patent dated October 5, 1852.*

Although the "slag" or refuse cinder of the iron manufacture accumulates at the rate of some three tons for every ton of iron that is made, and although the ironmaster is involved in serious expenses for the removal and permanent deposit of the useless material, hardly anything has yet been done to turn it to profitable account. It is true, that limited uses have been found for it in Dr. Thomson's application of it for copper smelting, and as the nucleus of Mr. Cuninghame's agricultural and stieil materials, but neither of these employments has yet in any way affected the case. Now, however, a third and more extensive vent has been found by Mr. W. G. Elliott of Blisworth, who uses the troublesome material for the manufacture of bricks, tiles, and pipes. In pursuing this manufacture, the patentee satisfactorily argues that iron may be profitably made, even on a small scale, by using the slag as it runs from

the furnace, instead of throwing it away, and covering up good ground with it. The coals and materials involved in the manufacture of the iron are obviously chargeable to that account, and it is assumed that the labour and general costs of the removal of the slag, as at present, will nearly pay for the moulding it into bricks. The turns at the blast furnaces are 12 hours each; and in a furnace doing full work, there are four men and sometimes two horses, with boys, constantly employed in the removal of the slag, which comes to 300 tons a week. Mr. Elliott is at present engaged in the establishment of his system for working the Northamptonshire ironstone. There does not appear to be any valid reason why the plan should not be most successful: the bricks are of excellent quality; their manufacture introduces a double course of economy, and the raw material is cheap and inexhaustible. As regards the last question, the best evidence is, that 8,000,000 tons of slag were produced and thrown away in 1851.

STEAM-PRESSURE REGULATORS.

MR. BAXTER, *Glasgow*.—*Patent dated March 18, 1853.*

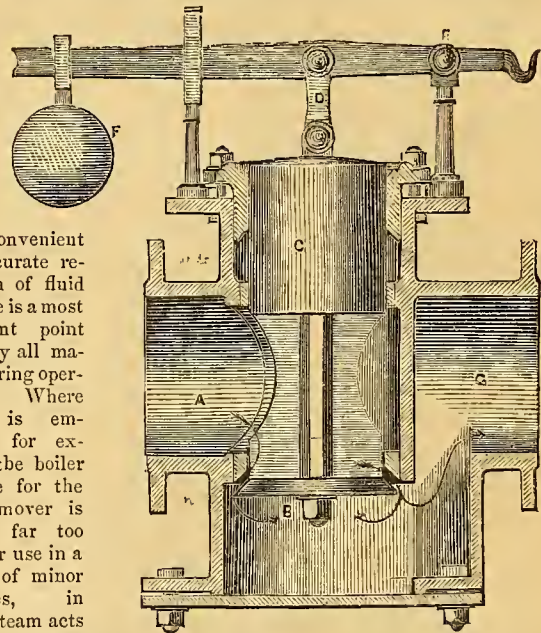

The convenient and accurate regulation of fluid pressure is a most important point in nearly all manufacturing operations. Where steam is employed, for example, the boiler pressure for the prime mover is usually far too great for use in a variety of minor processes, in which steam acts either as a means of developing

heat or power. Some contrivance must obviously be resorted to, for bringing down the initial pressure to an available point, and for retaining it at such determined standard, regardless of the variations occurring in the original reservoir of power.

Mr. Baxter's ingenious contrivance furnishes a means of doing this with very simple and easily adjustable mechanism. It is represented in vertical section in the annexed figure, as adapted for steam purposes. It is placed in the line of the steam pipe which conducts the steam to be regulated; the high pressure from the boiler, for instance, being brought in by a side branch, *a*, where it enters between a bottom lift-valve, *b*, and a plunger or piston, *c*, both of the same area, and both fast on one spindle, or connected to each other, so as to move together. The valve, *b*, guards the exit at the bottom of this valve-chamber, whilst the piston, *c*, working freely, but steam-tight, through a stuffing-box in the top of the chamber, similarly closes the passage in that direction. A link, *n*, connects the piston to an over-head lever set on a stud centre at *e*, and having an adjustable weight, *f*, hung over its opposite end, whilst behind the fixed centre is a hooked end to receive a counterweight.

The steam being admitted between the two equal areas of the piston and valve, presses upwards and downwards with equal force. Then, on loading the weighted lever to the intended point, the balance between the two areas of the piston and valve is destroyed, and steam passes off through the valve, *b*, and the discharge branch, *g*, at a diminished pressure, exactly corresponding to the weight placed on the lever. Hence any pressure less than that in the original steam-chamber, or the pipe, *a*, is readily obtainable, this reduced pressure being variable with the greatest facility, by sliding the weight, *f*, back or forward upon its lever.

DOMESTIC WASHING MACHINE.

J. ELDRIDGE, London.

Mr. Elridge proposes to supersede manual labour in the very tedious operation of clothes-washing, by supplying each family, say up to fifteen persons, with a small apparatus, 24 inches by 21, and 14 inches deep. Fig. 1 is a view of the complete machine, and fig. 2 is a detail of the actual operating portions detached. In using this contrivance, the tub, A, is half filled with warm water, of the usual temperature, with the

Fig. 1.

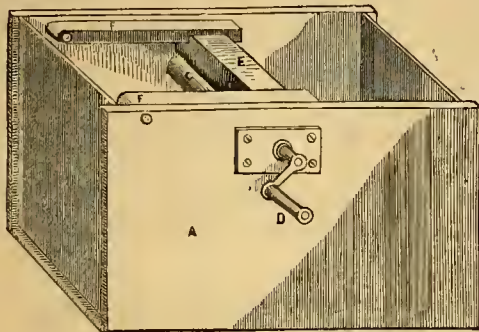

addition of the necessary amount of soap; then one end of the article, B, to be washed, is placed under the cord of the cylinder, C, and this cord is drawn tight by a slip-knot, so as to fasten the clothes to the cylinder. When this is done, the winch-handle, D, is turned round, back and forwards, about five turns each way; and this movement produces a continuous rotatory rubbing and thumping action with the friction lever, E, which rises and falls on the clothes on the cylinder. The arms, F, of the lever turn on stud centres in the sides of the tub, and a gentle pressure may thus be given to the rubbing action, whilst the handle is being turned. The machine may obviously be made of different sizes, to suit the family requirements; but the ratio we have given is the one adopted by the patentee. He states that an inexperienced girl is able to wash with it as many blankets in three hours, as would take fourteen hours in the hands of a professional washer.

Fig. 2.

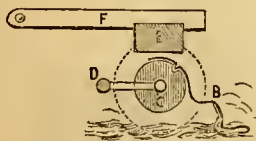

STEAM-ENGINES.

R. BURN, Edinburgh.

The steam-engine described under this specification, and figured in the accompanying engraving, was specially designed for driving the patentee's "Roller Cotton Gin" for long-stapled cotton. A simple and economical prime mover has long been wanted for sending abroad with these machines, as skilled labour is not easily obtainable in the cotton-growing countries, and building materials are very costly. The engine-house is usually a mere pit, laid with stout logs to carry the engine, and covered with a slight shed to shield the working parts from the weather. In our sketch, the cylinder, A, is cast in one piece with the sole plate, B, which may be either vertical or horizontal. The piston-rod, C, works through a stuffing-box in the cylinder cover, at the end farthest from the crank-shaft, and carries a cross-head, D, with a pair of parallel side-rods, E, running back alongside the cylinder to a corresponding cross-head, F. This cross-head has keyed into it one end of a rod, G, the other end of which works in a guide, H, whilst at I a connecting-rod is jointed to it, and passed thence to the crank, J. Thus the arrangement may be called a reverse steep-le-engine.

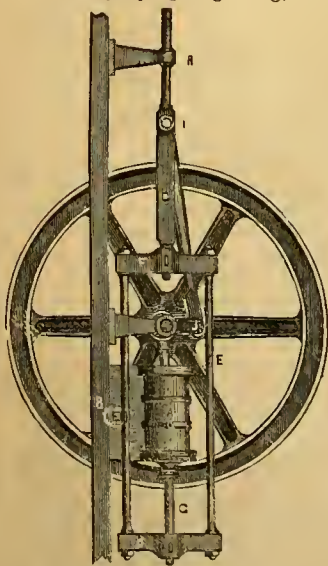

* See engraving and description in our "Monthly Notes," of the present part.

ELASTIC SCALES FOR THERMOMETERS.

W. MACKENZIE & G. BLAIR, Glasgow.—Patent dated Oct. 5, 1852.

This peculiarly elegant invention relates to the printing graduated scales for thermometers and other instruments of measurement, on sheets of elastic substances, such as vulcanized caoutchouc, with the intention that such scale surfaces may be elongated, or allowed to contract, at pleasure, to assist in their adjustment to varying lengths comprehended between any two fixed points. The lines of graduation, with their corresponding references, are set up in type, and impressions are then taken from this form upon the elastic sheets, either when the latter are slightly elongated or in their natural condition of tension.

According to the ordinary construction of thermometers, the scales must be made expressly to suit each mercurial tube, in order to insure even approximate accuracy; but by Messrs. Mackenzie & Blair's system, any number and variety of scales and tubes may be at once adjusted to each other with equal accuracy, without any special individual selection. That is to say, any two fixed points, as the freezing and boiling points, being determined and marked upon the tube, the elastic scale may be stretched to bring the freezing and boiling graduations thereon to correspond exactly with the tube marks; and if the elastic material is of uniform width, thickness, and elasticity, all the intermediate graduations will be found to agree with their corresponding lines of mercurial traverse in the tube. Vulcanized caoutchouc is not materially affected by thermal or atmospheric changes; and when soiled, it may be washed. The adoption of the elastic scales is also of very great advantage, in admitting of the enlargement of the number of index references beyond what is conveniently possible by the ordinary system of construction. The annexed figure represents a thermometer scale of this kind, as arranged with a greatly enlarged series of fixed points, in order to render the instrument of superior value for chemical, meteorological, and manufacturing purposes. Parallel hands of the elastic material answer sufficiently well for most purposes; but when extreme accuracy is required, the pieces are cut so as to be broader or narrower in the middle, according as they are to be drawn out or suffered to contract after printing. When this contrivance is applied to thermometers, the imprinting plate may be ex-

ABBREVIATIONS.

an., annual; b., boils; d., day; fr., freezes; m., melts; max., greatest; min., lowest; m. t., mean temperature; sh., in the shade; s., summer; w., winter; th. spr., hot or thermal springs; F., force of vapour in inches of mercury. Note.—The monthly temperature adjusted to the latitude of London.

SALT BRINE BOILS	225
Wat. Dead Sea boils	sp. gr. 1.211
Phosphorus distils	Alum 524-wat. 48 b.
F. V. 3246 (Dalt.)	Sulphur melts
Water b. bar 31 in.	215
Water boils	bar. 29 8 inches
Water boils, Madrid	bar. 27 74 inches
Water b. Sennevis	205
Wat. b. Heas. Pyren	Water b. St Roml
200	Bis 2+ld. 14 tin in.
Distillers' 3d wash	Wat. b. Mexico city
Water b., Bogota	195
Water boils, Quito,	Sodium fuses
190	Wat. b., Mt. Etna
Water b., Mt. Blanc	Water b., Antisana
Brewers' 3d wash	185
Distillers' 2d wash	Mix. malt-kiln heat
180	Brewers' 2d wash
Fr. spirit boils	175
ALCOHOL BOILS	sp. gr. 0.798
170	Sulphur sublimes
Carlsbad th. springs	Brewers' 1st wash
F. V. 1048 (Dalton)	165
F. V. 991 (Dalton)	Balkan th. sp. Turkey
160	Acetic ether boils
Wisbaden th. springs	Stearic acid melts
Albumen coagul.	155
F. V. 801 (Dalton)	F. V. 721 (Dalton)
150	Pyroxiclic spirit b.
Phosphorus inflames	Distillers' 1st wash
Wort, when drawn	145
Max. sun ht., Hong	Bees' wax melts
Ammonia b. 140	Min. malt-kiln heat
Aix-la-Chap. th. spr	Potassium fuses
Margaric acid m.	135
Sand Afric. deserts	F. V. 460 (Dalton)
130	Vineg. dist. in vac.
Max. Sun Ht ENGL	Tallow melts (Nich.)
Iod. subl. rapidly	125
Nero's Bath, Naples	F. V. 350 (Dalton)
120	Max. t. Bengalsh.
Alhambra th. spr Spain	Bisulphuret carb. b.
Bath th. springs	115
Thermopyle th. spr	Spermacetl melts
Fever heat	Stearine melts
Birds' blood heat	Heat of incubation
Feverish heat	105 Phosphor in.
100	PLEASANT BATH
Quadrupeds' blood ht	F. V. 186 (Ure)
100	Butter melts
Human blood ht.	95
Sulphuric ether b.	at Lond July 5, 1846
Max ht shade, Engl.	90
90	Pine pits, summer
Madras m. t., June	Acetic ferm. ceases
Madras m. t., t.	85
Mean sun ht., July	Mean sun ht., August
Mean sun heat, June	EGYPTOR m. an t.
80	Jamaica m. an t.
Pekin m. t.	Sydney m. t. Feb.
Madras m. w. t.	75 Mean sun ht Sep.
Mean sun ht., May	Rome m. a. t.
Acetic ferm. begins	Vinous ferm rapid
70	JULY, m. d. t.
AUGUST m. d. t.	Water boils in vac.
JUNE m. d. t.	65 Paris m. s. t.
Mean sun ht., Oct.	Mean sun ht., April
Agreeable	London m. s. t.
SEP. m. d. t. 60	MAY, m. d. t.
Edinburgh m. s. t.	Mean sun ht., March
60	55 OCT. m. d. t.
Temperate	Pine pits, winter
Mean sun ht., Nov	APRIL, m. d. t.
50	Mean sun ht., Feb.
Deep spring water	Mean sun ht., Dec
NOVEMB. m. d. t.	45 MAR m. d. t.
Mean sun ht., Jan.	FEBRUARY, m. d. t.
DECEMBER m. d. t.	Bottom deep lakes
London m. w. t. 40	Max density wat.
Edinburgh m. w. t.	JANUARY, m. d. t.
Olive oil congeals	35 Paris Jan. m. t.
Milan Jan m. t.	F. V. 0.20 (Ure)
Water freezes	Alcohol b. in vac.
Milk fr. 30	Sea water freezes
Vinegar freezes	25
Blood freezes	Finland m. w. t.
Pekin m. w. t.	20
20	STRONG WINES FR.
Splitzberg m. an. t.	Petersburg, m. w. t.
Oil of turpent. fr.	15 Quebec m. w. t.
F. V. 0.100 (Dalton)	Sydenm m. w. t.
10	London, Feb. 11, 1847
Alcohol 1 + wat. 3 fr.	5
SALT BRINE FR.	Labrador m. w. t.
Sulphur ac. fr. (1837)	Snow 1 + salt 1
0	London, Dec. 24, 1796
Siberia m. w. t.	5
Max. cold England	or Alcoh. 1 + wat. 1.
Mixt. snow 2 + salt 1	Alcoh. 2 + wat. 1 fr.
PROOF SPIRIT FR.	+ mur. amm. 1.
10	
Mixt. snow 5 + salt 2	
at Glasgow, 1780	

actly adapted to the irregularities of the expansion in different fluids, and all the impressions taken from it will be obviously applicable to any thermometer in which that particular fluid is used, to whose law or determined rate of expansion the original plate has been adapted. Few thermometer tubes possess a perfectly uniform bore; and hence, in such instances, the indications of the mercurial column are vitiated. But the elastic scale supplies a remedy for this evil, as the bands may be cut broader or narrower at the different points, corresponding to the variations in the tube, so that the differential expansion and contraction may coincide with the differential nature of the rise and fall of the mercurial column. Our illustrative figure, which is an impression from an actual scale-plate, shows how largely the patentees have added to the reference range of the common thermometer scale.

AERATED WATER APPARATUS.

F. MATHIEU, *Holborn, London.*—*Patent dated September 23, 1852.*

This is an improvement upon the very useful French invention now so highly valued in this country, as a means of preparing aerated beverages of various kinds, in small quantities, for domestic consumption. The

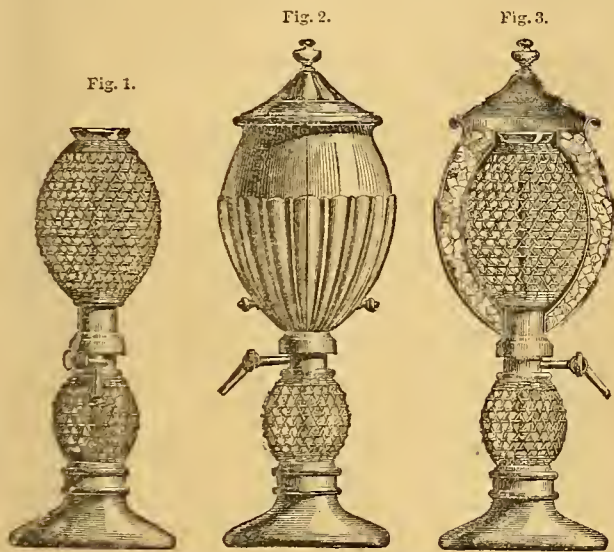

general principle of such machines is well known. On a neat pedestal is placed a large and a small oval vessel of glass, the small one at the bottom being arranged to hold the powders, whilst the upper large one is filled with water. A small quantity of water is then allowed to flow down amongst the powders, and the resultant gas then rises and aerates the water above. The ordinary apparatus is represented in fig. 1, the two vessels being surrounded with wire or cane netting, to prevent injuries from the casual fracture. Fig. 2 is an external view, and fig. 3 a vertical section of one of M. Mathieu's improvements. In this arrangement, the upper vessel is surrounded by an external shell or vessel, so as to leave a space between the two for the reception of cold water, freezing mixture, or ice, as delineated in fig. 3, this chamber being covered over by a vase lid. This forms an excellent refrigerator. Another branch of the invention relates to an elegant plan of protecting the glass containing vessels. This is done by depositing metal upon the glass, in any suitable open ornamental figure, by means of the electrotype process. Fig. 3 is an elevation of the patentee's improved filter. It consists of porous stone, shaped to represent an ordinary bottle, but mounted with metal at its upper part. This filter is extremely rapid in action. When placed in a reservoir of water, or in a stream, the water quickly filters through its sides, and furnishes the interior with a clean



and pure supply. This little contrivance promises to be a most useful convenience.

PORTABLE BUILDINGS.

J. H. PORTER, *Birmingham.*—*Patent dated November 5, 1852.*

The improvement introduced under Mr. Porter's present patent, relates to the construction of the uprights, or supports, of portable houses, so as to secure lightness and simplicity of details. Our illustration represents horizontal sections of a corner-post and a plain wall-post of this kind. Each consists merely of the wooden pillar, A, down the sides of which are secured the curved strips of corrugated iron, B. These metal strips are formed by simply cutting a plate of corrugated iron longitudinally down every alternate corrugation by a pair of circular shears. For the corners, the iron strips are bent a little more, to suit the angle. Mr. Porter also proposes to construct the roofs of buildings on the same principle—the main rafters being similarly fitted with strengthening plates of metal. It is intended, also, to apply this principle in the construction of fences of corrugated iron, or planking. Such a contrivance obviously affords great strength at an economical rate—results which the inventor has arrived at, after long practical experience in this peculiar branch of construction.

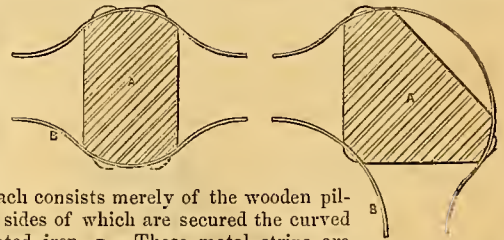

BLOCK SHEAVES.

ARCHIBALD BROWN, *Glasgow.*—*Patent dated October 4, 1852.*

Hitherto the bushes of ships' blocks have always been attached to the wood of the sheave, by lateral rivets passing through the bush and into the sheave. Mr. Brown makes a much neater piece of work, whilst he avoids splitting, and introduces an element of economy, by fastening the bush in position, by pouring melted block-tin or lead round the bush when entered into the sheave. Fig. 1 is a side view of a sheave so fitted,

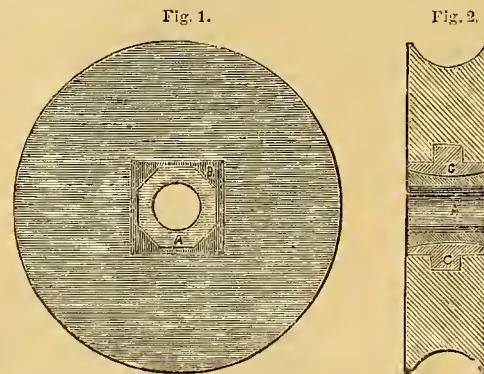

and fig. 2 is a transverse section to correspond. A hole, somewhat larger than the diameter of the bush, A, is first cut out of the centre of the sheave, and the bush, which, in this example, is octagonal in transverse section, to prevent revolution in its seat, is then placed in the centre of the aperture, and the molten metal, B, is poured into the annular space surrounding it. As shown in fig. 1, the hole in the sheave is square, so that the metal seat, B, cannot revolve in the sheave, neither can this metal seat move laterally, by reason of a central recess, or annular groove, C, which is cut in the sheave, and receives the retaining metal, where the latter is poured in; thus forming a retaining band or zone upon the outside of the seat. Similarly, lateral motion is prevented between the bush, A, and the metal, B, by slightly recessing the external surface of the bush in the centre, as shown in the section, fig. 2. The sheave is finished up to a flush surface, by turning down the superfluous metal, so as to present a clean face on each side. It is obvious that the same system of holding may be carried out with various sections of bushes; and Mr. Brown shows several other modifications for this purpose.

He also shows another plan, wherein the bush flanges bear firmly upon the wood in the hole, so that a firm connection is established between the sheave and its bush, and the melted metal or composition is then poured in, to fill up the internal space surrounding the bush, and lock up the latter in its seat. The superior neatness and efficiency of these sheaves is plainly apparent.

ROASTING JACKS.

T. SUTTIE, *Greenock*.—*Patent dated October 13, 1852.*

Mr. Suttie's invention relates to the application of water-power for turning the slowly-revolving apparatus, technically known as a "jack," employed for producing the rotation of meat during the roasting process. The improved apparatus takes the form of a mantel-piece clock. This is fitted up on the kitchen chimney-piece, and contains a small breast water-wheel, worked by the flow of water from a small pipe. Fig. 1 is

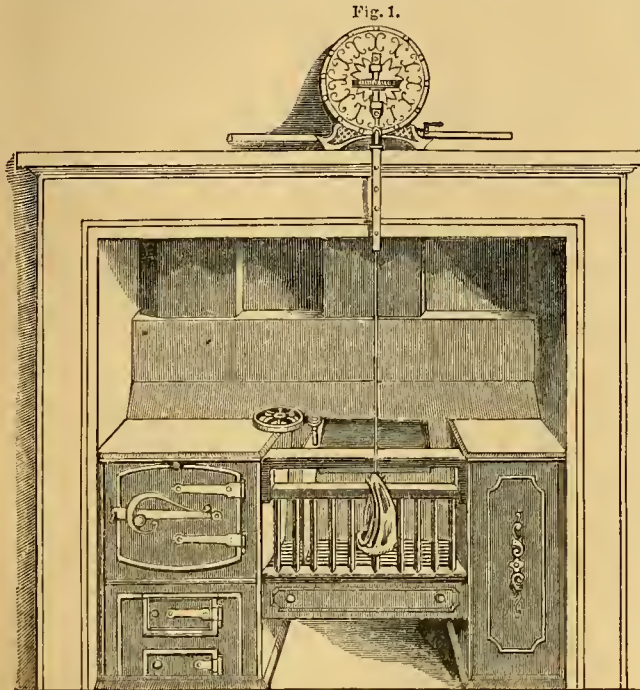

an elevation of a kitchen range so fitted up, and showing, also, Mr. Suttie's previous invention of a boiler with central flues. Fig. 2 is a front sectional elevation of the jack movement detached, on a larger scale, and showing the actuating water-wheel. Fig. 3 is an external

Fig. 2.

Fig. 3.

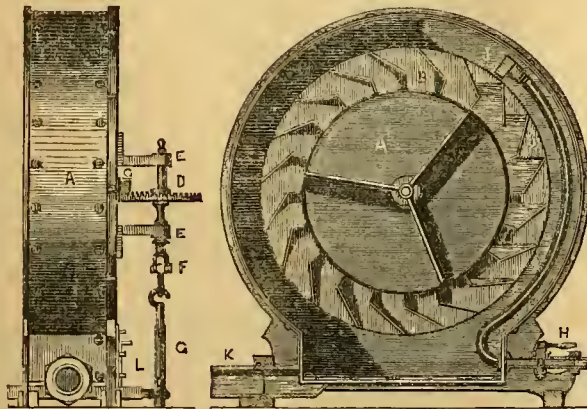

edge view at right angles to fig. 2. It consists merely of the flat circular case, A, just large enough to receive the bucket, or overshot water-wheel, B, the shaft of which projects at the front of the case, and carries a bevel pinion, C, gearing with a bevel-wheel, D, on a vertical spindle revolving in the bracket bearings, E. This spindle has a universal joint-piece, F, at its lower end, for connection with the adjustable suspension link, G, for the meat. The water for working the apparatus is supplied by the pipe, H, which enters the case near the bottom, and sweeps round the wheel inside, finally delivering its gentle stream of water into the buckets of the wheel at J. The waste, or used water, falls down into the bottom of the case, and flows off by the wide waste-pipe,

K, and a small sliding door is fitted at L, for the removal of dry solid accumulations in the case.

By this little apparatus, an excellent motive power is obtained, at once cheap, noiseless, and easily governable by the adjustment of the fluid flow.

EVER-POINTED PENCILS.

ROBERT PINKNEY, *Long Acre, London*.—*Patent dated October 13, 1852.*

Mr. Pinkney's very ingenious and useful invention is an improvement upon the more modern class of "ever-pointed" pocket pencils, which has succeeded the original costly pencil of Mordan. Our engraving represents the new pencil in longitudinal section. It consists of a main outer shell, or tube, A, of wood, ivory, or other material, having an internal screw-thread along its entire length. To this prolonged nut is fitted the short externally screwed piece of metal, B, a pin, C, from which projects into a longitudinal slot in a central tube, H, of small bore, running throughout the length of the pencil. One end of this tube is fast in the adjusting head, D, at the upper end of the pencil, this head being loosely inserted in a plain socket in the end of the shell. The other end of the tube, H, turns loosely in a bearing, E, screwed into the opposite end of the shell. The marking lead is in one long piece, extending from the point, J, through the ivory or metal-holding point, F, and up through the tube, H. On the front end of the screw, B, is a small projection, termed the "propeller," fitting into the interior of the tube, or lead-holder, H, and in contact with the extreme after-end of the lead. The result of this clever contrivance is, that, on turning the head, D, the lead is gradually screwed forward to the required marking distance; for, as the screw, B, must turn along with the tube, H, it follows that the screw must traverse along the internal screw-threads of the shell, A. This movement is allowed for by the slot in the tube, H; and the lead is therefore pushed directly forward by the propeller pressure due to the screw traverse. Such a pencil presents a smooth exterior from end to end; and whilst it is much pleasanter to use than the ordinary one with external projections, it is adjustable with the greatest facility.



GAS BURNERS.

D. LAIDLAW, *Glasgow*.—*Patent dated October 11, 1852.*

Instead of iron, brass, or porcelain, ordinarily used as the raw material of gas burners, Mr. Laidlaw uses such metals or alloys as are easily fusible, as tin, or tin and regulus of antimony. The metal is cast or moulded to the required form of burner, or nearly so, in metal or other moulds, so contrived, with cores or mandrels, that the bore of the burner may be formed in the act of casting, leaving the actual egress apertures for the gas to be drilled; and either the main bore alone, or the smaller egress apertures for the gas, also, may be so produced in this way; or the actual egress openings for the gas at the point of combustion, may be formed by subsequent drilling or cutting in the usual manner. By this means the burners may be produced entirely by casting, or so as to require only a slight amount of labour and attention subsequently. By this system of manufacture, the burners are produced with uniform accuracy, whilst the materials of which they are made are not liable to be acted on, either by the gas itself, or by the humidity of the atmosphere. Any metal or composition capable of being cast with facility in this manner, in separate moulds, and possessing the advantages of freedom from oxidation and deposit, may be used; and, for some purposes, the orifice and portion exposed to the flame is gilt or plated, or otherwise treated, with a defensive coating of gold, silver, or other metal or material, as a preservative covering. For example, according to our modification, a nib, made of glass, china, or other incorrodible substance, is inserted into the top of the burner, so as to protect the body thereof, whether such burner is made according to the general improvements, or according to the old process. The invention promises to effect a most important improvement in gas fittings.

QUARRYING SLATE.

S. F. COTTAM, *Manchester*.—*Patent dated Oct. 18, 1852.*

The resistless force of hydrostatic pressure has found a new application in Mr. Cottam's invention, which is simply the adaptation of an ordinary hydrostatic press for detaching blocks or slabs of slate from

the quarry bed. This adaptation may be effected in many ways, of which the patentee presents two modifications in his specification. From these we have selected the one illustrated by our sketch. The press, A, is laid horizontally in a recess made to receive it, on the surface of the quarry above the level of the excavation, the head of the ram, B, being made to bear against the inner face of the top of the slab, C, to be detached, whilst

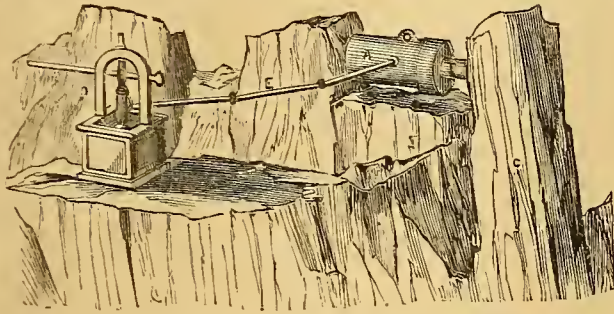

the water cylinder abuts against the back end of the recess. The working pump, D, is placed back out of the way, on the nearest convenient level, and a connecting pipe, E, is led from it in the usual way. In the other plan, the entire pressure apparatus is set on the floor of the quarry, and a recess is cut out in the quarry face, beneath the slab to be taken out. The press is entered into this recess, and the ram, which works upwards, carries a wedge point for splitting off the stone. For large works, the plan offers some important advantages.

Fig. 1. Fig. 2. Fig. 3.

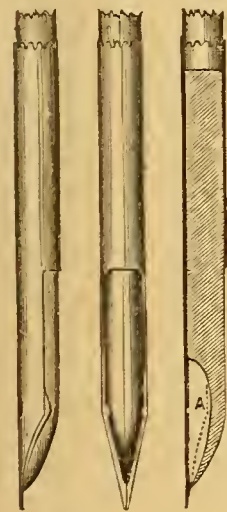

REGISTERED DESIGN.

PEN, RESERVOIR, AND INK HOLDER.

Registered for MR. R. WATKINS, London.

The aim of Mr. Watkins, in this design, is to enable a pen to hold as much ink as will write a long letter, and thus save the trouble of dipping and refilling. Fig. 1 is a side view of the pen and its reservoir; fig. 2 is a view at right angles to fig. 1, showing the back of the reservoir as it lies under the pen; and fig. 3 is a longitudinal section, corresponding to fig. 1. The plan offers some advantages in point of neatness in writing. The ink is supplied to the chamber, A, by entering it between the chamber, or reservoir, and the pen, thus preserving the pen in a clean condition; and as the inkstand will thus be little in request, it may be kept covered over to keep the ink clear and fluid.

CORRESPONDENCE.

ON THE APPLICATION OF THE BLAST TO SMELTING FURNACES.

It is a serious question as to whether the increase of quantity in the yield of blast furnaces, resulting from the introduction of the hot-blast, has not been more than compensated for by the deterioration of the quality. This has not yet been answered to the satisfaction of large consumers of iron. If a certain ratio between the quantity and quality of iron, produced from a determined mass of ore, really exists, and if, in proportion as the yield is reduced, the quality is increased, the point at once assumes a plain commercial aspect. In that case, the manufacturer's object would be, to work his furnaces so that the yield and quality should be such as would take best in the market; and be would naturally be disposed to go to the utmost verge in obtaining quantity, so that the quality be still good enough to preserve his position as a seller. I am, however, of opinion, that there is not necessarily any connection between quality and quantity; and my present object is to point out the causes of deterioration, and to suggest an application of blast, by which both quantity and quality may be obtained.

It will be readily understood, that, in the cold-blast furnaces, the part

immediately opposite the tuyeres is not the seat of the most intense heat; for the admitted air must absorb a portion of the furnace heat, and thus lower the temperature in that neighbourhood. This weakens the oxidizing power of the atmosphere, through which the liquid metal falls to the hearth, where it is protected by a covering of cinder; and while acquiring the heat necessary for its action upon the furnace contents, it becomes somewhat diffused, and acts with purifying effect upon the materials in the upper part.

Not so with the hot-blast. The heat of the entering air must increase the rapidity of its action upon the combustible materials in the furnace. Its intense effect, which may account for the superior yield, is confined to one part, for the oxygen thus supplied is speedily consumed, and the heat is insufficiently diffused throughout the furnace. The impurities contained in the coke and ore are not driven off; hence portions of the foreign matters are incorporated with the iron made on the hot-blast principle.

By heating the air, also, its oxidizing power is increased, and hence the metal is somewhat oxygenized in passing into the hearth, and its quality is therefore injured.

The general inferiority of hot, in comparison with cold-blast iron, then, seems to be, the concentration of the smelting process in one part of the furnace, and the intense oxidizing power of the atmosphere through which the liquid metal passes on its way to the hearth. The remedy which I propose is, the admission of a graduated blast at different altitudes*—three separate parts, for example—instead of directing the air all to one place, as at present.

The prospective results of my plan are—the oxygen would be more generally diffused through the furnace, the temperature of the upper part of which would be increased; the excess of oxygen which could be supplied in this way would unite with the impurities—as sulphur, for instance, contained in the coke and ore—and carry them off in the gaseous form. From the superior temperature of the upper part of the furnace, the flux and ore would become more thoroughly mixed in descending through the furnace; the ore would be gradually fluxed, so that the blast need not be so intense below the point of greatest heat, and thus its oxidizing influence would be, in a great measure, avoided. Finally, it is probable that a fan-blast might be substituted for the existing cumbrous blowing machinery.

May, 1853.

P.

THE QUADRATURE OF THE CIRCLE; A PUZZLE FOR MATHEMATICIANS.

- Make A B C a right angle;
- A B = $\frac{1}{3}$ diameter;
- B C = $\frac{1}{5}$ " "
- B D = $\frac{1}{5}$ " "
- B E = $\frac{1}{7}$ " "
- B F = $\frac{1}{12}$ " "

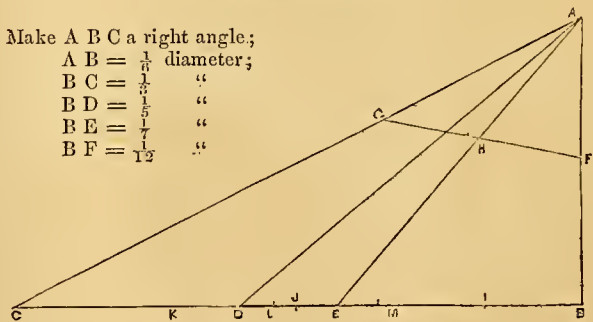

Join A C, A D, A E, and draw through F a straight line, cutting A E and A C, so that H G = E D.

Then $2B C + F G = \frac{\pi \text{ diam.}}{4}$, whence may be derived the square.

Otherwise,

- Make B C = $\frac{1}{3}$ diameter;
- B D = $\frac{1}{5}$ " "
- D I = $\frac{1}{7}$ " "
- I J = $\frac{1}{9}$ " "

Divide C D and D J in K and L, so that C K, K D, D L, L J, are the differences between the terms of a harmonical descending series, and bisect B K or I L in M.

Then B M = F G, or $2B C + B M = \frac{\pi \text{ diam.}}{4}$.

Glasgow, May, 1853.

FUTURUS.

* [Mr. Andrew Barclay, of Kilmarnock, patented this system of working in 1850. It has not yet been brought into use, although it obviously possesses features of sufficient importance to warrant a trial.—Ed. P. M. Journal.]

IRONFOUNDERS' CASTING-LADLES.

I have to apologise for again troubling you, by resuming the subject of ironfounders' casting-ladles; but another fatal accident at Mr. Grisell's Foundry, together with the remarks of Mr. Slight, which appear to me to show how little the subject is understood even by those who should be practically acquainted with it, induce me to think that a more detailed explanation of my views, and of the manner in which these have been arrived at, may be of some service.

I would, in the first place, observe, that the plan described by Mr. Slight appears to be both simple and safe, and, when employed in connection with moulding-boxes specially adapted to it, must be very efficient. The trouble, however, of providing a firm support for the ladle, particularly in loam-work, where the runners are made with sand, sometimes on a level with the floor, and at others considerably elevated, besides occurring in every variety of shape and position, will, I am sorry to believe, be a hinderance to its general adoption. Whilst testifying to its merits where arrangements are made to adapt the moulding-boxes and runners to it, I must be allowed to question whether the cost of these arrangements would not be greater than that of a ladle, applicable to almost every case, and capable of pouring from either lip. Though I do not attach much importance to the capability of pouring from either side, still cases often occur where it would be a great advantage. Nor do I consider that my ladle is applicable to every conceivable case, or that it is safer than the ordinary screw-gear ladle, when all its parts are made strong enough—a precaution, without which Mr. Slight's is also unsafe; and it was the object of my first communication to give proportions that would insure sufficient strength.

I regret that your able correspondent should have expressed an opinion in reference to the power to turn the ladle, which, coming from him, is likely to have some influence in preventing the adoption of measures of safety. That the means proposed are safe, he tacitly allows. Indeed, the first of his remarks conveys the idea that they are superfluously so. It is very true, that the ladle may be so hung as to require very little power to turn; but can it be so hung, consistently with safety? It must be remembered, that it is not the moving and turning of a solid, of a fixed form, which is under consideration, but of a vessel containing a fluid body, assuming new forms, and changing the relation of its centre of gravity to the centre of motion during the turning of the ladle. If it were convenient or determined on to make ladles in the form of regular solids—as of a sphere, for example, or a horizontal cylindrical segment, having the journals in the axis of the figure, and the deficient portion of the figure compensated for by counterweights—then the fluid metal might be practically considered as stationary, with the ladle or outside casing gradually revolving from under it, without other obstruction than the slight friction of the fluid mass against the interior of the vessel. Such a ladle could never capsize, for the centre of gravity of its contents would, under all circumstances, be in a direct line below the centre of motion. A balanced hemispherical ladle would, I believe, be the safest and most easily managed of any that could be made; but thinking that its great size, compared with its capacity, together with other minor objections, would prevent its general adoption, I did not before propose it, but sought to make a ladle that should be about an average of the shapes most in use, and at the same time be safely worked. With the view of obtaining data for calculations, I constructed an experimental vessel, 6 inches in diameter, and the same in depth, having arrangements for fixing the journals at any desired position. These were $\frac{3}{8}$ inch in diameter, and rolled upon steel edges. To one of the journals was fixed a vertical arm, with a sliding weight to balance the ladle; and on the other was fixed a pulley, of 6 inches diameter, from the periphery of which was hung, by a thread, a small vessel to contain shot, by means of which the turning power was obtained—the vessel, of course, being balanced. The fluid employed was water. The contents of a vessel of such a form can only be in equilibrium in some particular position, depending upon the placing of the journals.

When the journals were fixed in such a position that the ladle had no tendency to capsize, but returned to its vertical position as soon as the turning power was removed, to whatever extent it might be turned, it required increasing accessions of shot to turn up the ladle until $\frac{1}{3}$ of its contents were poured out, and from this point it required decreasing accessions until emptied. When the journals were fixed lower down, the vessel, when nearly full, was unstable or top-heavy, and required increasing retarding power to prevent its capsizing whilst a certain quantity was being poured out. After this, a decreasing retarding power was required for a certain distance; and then again, an increasing turning power until another certain point was reached; after which, a decreasing turning power was necessary to empty it. The lower the journals, the greater the amount of retarding power required, and the less that of

the turning power. When the journals were fixed at a point $\frac{1}{3}$ of the vessel's depth from the top, the power required to retard and that to turn it were equal—namely, $\frac{1}{3}$ of the weight of the entire contents of the ladle; and this was found to be the least power that would work it, either backwards or forwards, whatever was the position of the journals. If they were so placed that less power was required to retard, more was necessary to turn up, and *vice versa*.

I need scarcely state that the relative amounts of power required will vary with different forms of vessels, the elliptical-mouthed ladles requiring less than the cylindrical. I tried experiments with different forms of ladles in the manner above described, and propose it as a cheap practical plan for determining the position of the journals for any form of ladle: of course, in calculating from data obtained in this way, allowances must be made for friction, and for other contingencies.

Another point of great importance to be considered is, the difference in the amount of retarding power required, according to the velocity of the stream. Thus, the width of this stream, in one case, may not be $\frac{1}{10}$ of what it is in another; and the greater the width the greater the velocity and momentum, and the greater the prepouderance on that side the centre of motion, and consequently, also, the greater the retarding power required. When all these items are taken into account, I think it will be allowed that much more power is required than that barely necessary to "overcome the friction of the gudgeons."

To obtain data on which to form a general rule, it is necessary to take the averages of several quantities, such as the relative weight of the ladles and linings to that of their contents—the relative diameter of the journal to that of the ladle, &c.

I need not go over all the calculations necessary, but merely state the result. I have estimated all probable resistance at $\cdot 06$ of the weight of the contents of the ladle, acting at a distance from the centre of motion equal to the radius of the latter, and have calculated, and experimentally proved, the relation of the power as transmitted to the teeth of the wheel to the power applied at the handle. From these calculations, I deduce the following approximate rule:—When the form of the ladle, the pitch and diameter of the screw, and the length of the handle, are the same as those given in my former communication, multiply the contents of the ladle in lbs. by $\cdot 06$, divide the product by the ratio of the diameter of the screw-wheel to the diameter of the ladle, multiply the quotient by $\cdot 078$, and the product will be the power in lbs. required at the handle. The power applied to a handle of the kind described cannot much exceed 60 lbs., which is the utmost that two ordinary men can steadily apply at the speed usually required. To ascertain this, the following experiment was made: a light wooden disc, 18 in. in diameter, was keyed on to the socket end of a pouring key, 12 feet long, which rested on a horizontal bar to avoid friction; the other end of the key was supported by the left-hand, and the handle turned by the right, whilst a cord, to sustain weights, was wound upon the periphery of the disc. From 12 to 15 lbs. was all that could be raised continuously, and at any moderate velocity, with ease; and from 25 to 30 lbs. was the utmost that could be raised during 4 or 5 revolutions with any degree of regularity. More power than this could be applied by means of a cross-handle on the end of the key, but then a support for the key would be required, and the men would have to be close to the ladle, following its motions, and changing their position to correspond. This objection is great, and well obviated in the plan described by Mr. Slight; and I have endeavoured to obtain the same end by constructing the long pouring key with a universal joint.

If the power required by the foregoing rule exceeds 60 lbs., it is obvious that, if we adhere to a system comprehending uniformity of proportion, which is, on many accounts, advisable, we must apply an additional wheel and screw, to reduce the amount of power required. There are two objections to increasing the size of the wheel much above $\cdot 8$ of the ladle's diameter. In the first place, it would be very inconvenient in practice, and the wheel would be very liable to damage if it projected beyond, or even reached, the bottom of the ladle; and, secondly, it would expose the top of the wheel, the screw, and its bearings, to the heat. To be most efficient, the wheel should be as large as possible; but, I believe, it will be found to be inconvenient if it exceeds the proportions proposed. Now, if we take an example, say a 5 ton ladle, and work it by the rule, we have 5 tons = 1100 lbs., and

$$\frac{1100 \times \cdot 06}{\cdot 8} \times \cdot 078 = 64 \cdot 35 \text{ lbs., the}$$

power to be applied at the handle. This capacity of ladle is taken as the limit for one wheel, because about 60 lbs. is the most that can be applied at one handle by two men. I do not, by any means, assume that this is the actual power required under ordinary circumstances; but it is what may sometimes be required, as before stated. The limit for two wheels will be found, by the rule, to be 10 tons; but as the proportion of metal that may probably set to the ladle is less than for 5 tons, and as the handles are to be worked simultaneously by a connecting-link,

and more power can be conveniently applied on an emergency, I have set the limit at 12 tons.

To a casual observer it may appear paradoxical, that a ladle should require so great an amount of power to insure perfect command over it, whilst large ladles without gearing are daily being worked by one or two men, and, to all appearance, with great ease; but as far as my experience, as well as that of others, goes, all these easily-worked ladles have their journals more or less too low; and the real fact of the case is, that instead of the friction of the journals being the only resistance to be overcome, this very resistance is in many cases a preventer of accidents, the tendency to capsize due to the want of equilibrium being retarded in its action by this friction of the journals, until sufficient metal be poured out to restore equilibrium. It may be considered an advantage to have a ladle capable of being turned up so easily; but let it be required, as is not unfrequently the case, to stop the pouring, perhaps just at the moment of greatest tendency to capsize, it will then be found, that just in proportion to the ease with which the ladle can be poured, will be the difficulty of stopping and righting it. This is a purely practical objection to easily-poured ladles; for it is far from uncommon to pour two, three, or even more moulds at different runners out of the same ladleful.

What has been said respecting ladles worked by hand, applies equally to geared ladles having their journals low, as in most cases. The lower the journals are placed (within certain limits), the easier will the ladle be poured, because its tendency to capsize will be greater—and this preponderance, however great it may be, must be supported by the teeth of the wheel, minus the friction of the journals—and the easier the operation of pouring, the more difficult will it be to work it back.

With regard to the objection urged against the four suspension-rods, I must observe that, for reasons before stated, a similar motion seems to me to be necessary. A sufficient support, also, must be provided for the shafts of the pinion and screw-wheel. If I could have devised a simpler and more efficient support, I should not have proposed the two outside rods, which are not intended as suspenders, but merely as supports to the shafts. The two inside rods are to be made sufficiently strong to carry the whole load, and to resist their share of the lateral strain. I have hitherto thought it quite possible to make journals so strong, and to fix them so securely, that "bending, jamming in the eyes, and the inevitable break down," were quite out of the question, unless they became red-hot. As, however, I had never heard of this taking place, I did not anticipate the objection, to meet which, should it be at all likely to occur, it would be better rather to increase than decrease the number of rods; for, admitting the possibility of the journals bending or getting out of line, it must be in the direction of the weight, and consequently their outer ends will be raised, and lie oblique in the eyes of the side rods, the wheels will be thrown out of their vertical machinery, and if forced to turn by powerful machinery, the result depicted might ensue. There is no arrangement against which similar objections cannot be raised; but in this case it really appears to me that the thing objected to is actually a preventive of the derangement, the possibility of which occasions the objection. Further, supposing the journals became red-hot close to the ladle, they would only bend at the hottest place, and thereby simply crank the journals inside the suspending-rods, and I do not think that would accomplish the "inevitable" breakdown. On the whole, then, and after reconsideration, I hold the advantage to lie with the "four suspenders."

In conclusion, I would express a hope that further consideration may be given to the subject by others, and that some safe principle may be determined on, and generally adopted.

Blackwall, 1853.

HECTOR SHORT.

EXHAUSTING SIPHONS.

In your *Journals* of last February and May, I perceive notices of a siphon for watering ships, patented by Lieutenant James A. Heathcote, Indian Navy.

I think it only fair that the public should be reminded, that the first application of the siphon to the watering a ship from a tank vessel, was by Lieutenant W. Rodger, who submitted his plan to the Admiralty in November, 1816; in consequence of which, a siphon was constructed in Plymouth yard, in 1817, under his superintendence. It was tried on board the *Queen Charlotte*, at Portsmouth, November 18, 1818, and on board the *Impregnable*, at Plymouth, on the 30th of the same month; the siphon, on the latter occasion, delivering 27½ tons per hour, in the middle tier.

Lieutenant Heathcote appears to have improved on the method of exhausting the air, which is, as far as I can perceive, the only difference between his plan and that of Lieutenant Rodger.

Southsea, May, 1853.

HORACE J. ROCKWELL.

ASTLEY'S LIFE-BOAT.*

Hitherto the great points aimed at in life-boats have been merely displacement of water, and the qualification of righting when accidentally turned over. But in my air-chamber, or conc-boat, the case is very different, for it possesses many other peculiar properties. It would be next to impossible to turn over my boat by any power which will overturn ordinary boats. My opinion is, that the great importance laid upon the righting qualities of boats, has caused other more important particulars to be quite overlooked. Many persons find fault with my boat as being deficient in speed; others—and good authorities too—say, "We never mind speed in a life-boat, provided we get safety." It has also been suggested, that if the cone were to get injured, the boat would cease to be safe. For this casualty I have provided two remedies: one is, the placing an inflated india-rubber cushion inside the upper part of the cone. This cushion would be about 10 feet long, and it would follow the shape of the cone, being capable of being inflated from the inside of the boat at pleasure. My other means of safety consists in making the cone double—that is, with an intermediate space—one cone being, in fact, inverted over the other. One cone might thus be stove in without hurting the boat in the least.

P. H. ASTLEY.

Stratford, Essex, May, 1853.

CAWOOD AND SUNTER'S FERRULE AND SAFETY-VALVE LEVER.

I think the little contrivance, represented in the annexed sketches, is well worthy of a place in your columns, more especially as many of your correspondents have, from time to time, introduced the subject of improved or isochronous spring-balances. It is the registered invention of Messrs. Cawood and Sunter of Derby. With it, it is impossible to lock the safety-valve down by screwing the adjusting nut, and the valve will continue to blow off freely, although the nut is screwed fast down; and when the boiler is up to its maximum working pressure, that pressure cannot be unthinkingly increased, as with the ordinary apparatus. The main figure is a side elevation of a spring-balance and part of lever thus fitted. Beneath are three detached views of the ferrule, and at the bottom a section and plan of the lever end. The ease with which the common valve may be tampered with, is a great objection; and although lock-up valves and tell-tale indicators have had their day, the rule with builders now seems to be, to have two common valves at different parts of the boiler. Here we have the danger of over-screwing—to remedy which, a ferrule was introduced between the end of the lever and the top of the balance. Still, boilers would blow up, even with this precaution; and, on examination, it was found to be no precaution at all, and that, as some balances were made, it was still possible to screw down the lever so hard on the top of the ferrule as to make it nearly a fixture. Messrs. Cawood and Sunter's improvement completely remedies this objection; and, after a series of trials, the Midland Railway Company have ordered all their engines to be fitted up in this way.

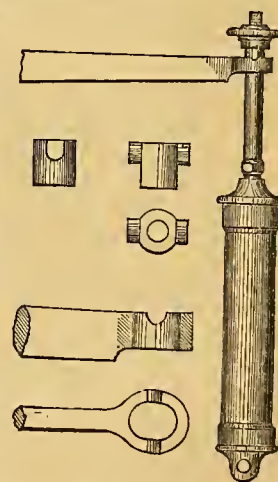

J. F.

π

May, 1853.

PROCEEDINGS OF SCIENTIFIC SOCIETIES.

INSTITUTION OF CIVIL ENGINEERS.

NOVEMBER 9, 1852.

JAMES MEADOWS RENDEL, ESQ., PRESIDENT, IN THE CHAIR.

This was the First Meeting of the Session.

The paper read was "On the Improvement of Tidal Navigations and Drainages," by Mr. W. A. Brooks, Mem. Inst. C. E. The object of the communication was chiefly to elicit observations from members, and the narration of facts which might be usefully employed hereafter, in an investigation into the laws which govern the flux and reflux of the tide in estuaries. The author,

* See also page 59 in the present number.

after alluding to the impediments to improvement, arising from the popular prejudice against such constructions as would appear, by their bulk, to diminish the space for the tidal water, proceeded to show, with how little reason the hackneyed phrases, "encroachment upon navigation," and "abstraction of tidal water," were applied, indiscriminately, to works which the experience of engineers pointed out as adapted to ameliorate the flow and ebb of tidal waters.

He then showed that estuaries were of two classes. The first and best kind were bounded by shores, gradually receding from each other as they approached the ocean, with their navigable channels bearing a large proportion to the full breadth of the stream at high water, as in the case of the Thames, &c.

The second and inferior kind had tortuous channels, of uncertain and varying capacities, and with great disproportion between their relative widths at low and at high water.

The first class afforded perfect drainage to the country, on account of their capacious low water channels, in which the declination of surface was very gentle; the transmission of the tidal wave was therefore quick, and it was able to turn early, and attain a head to overcome the ebb, so that the interval of stagnation, or rest at sea, was very short, which last was the best test for the general good state of a navigation. At the mouths of such rivers there were rarely any bars.

The features of the second class of estuaries were directly opposed to those of the first class; the body of water was generally divided into several tortuous streams at low water, their capacity being greatly disproportioned to the width of the bed, which offered an undue resistance to the flow and the ebb. There was great fall, and consequent rapid loss of height in the tidal column, which caused a considerable interval of rest between the currents of the flood and the ebb, during which period a great amount of deposit took place. Numerous other features, and their results, were carefully pointed out, and reasoned on.

The best means were then described for promoting the natural action of the tidal water in rivers of good condition, so as to combine the most efficient drainage of the country, with the best state of the navigable channel. The Mississippi was then given as an instance of the effect of a large volume of water, densely charged with alluvial matter, falling into the nearly tideless Bay of Mexico,—producing a delta of great extent, and so diminishing the depth of the harbours, as to prevent vessels of any considerable tonnage from frequenting the coast. This led to the enunciation of the axiom, that in the improvement of rivers of the second class, although the river walls might not be raised above the level of half tide, they would suffice to determine the future condition of the bed of the estuary, behind and parallel with them, as the conversion of those reclaimed spaces into land was simply a question of time, and of the amount of alluvial deposit brought down by the floods. Thus, by this system, the same effect would be eventually produced, as by enclosing the space with full-tide walls, it being impossible to keep open the rear space as receptacles for tidal water.

The tendency to deposit, in consequence of the formation of breakwaters, in certain situations, was fully considered, with the question of the difference between the relative times of high water, as affording a true test of the condition of a river. This latter view should be received with caution, as the only certain test was the condition or progress of the tidal wave throughout the entire period of the flow. Thus the tidal wave would pass more quickly through a broad and straight reach, after the sands were covered, although its progress might have been very slow in the earlier stage of the tide, in consequence of the opposition of the sandbanks, which would form, for the nascent flow, a restricted and tortuous course, through a reach which, at high water, might appear well adapted for the ready transmission of the tidal column.

The Author then described the broad principles of his own practice, in training the current of a river, to be based chiefly on the construction of full tide timber groynes, or jetties, at right angles to the intended new line of river frontage. These structures, raised at a cost of from twelve to thirty shillings per running foot, had been aptly designated, by Sir W. Cubitt, "as the scaffolding for forming the new line of shore;" and as "making so much more land, and bringing the shore to the form represented by a line drawn through the ends of the groynes." In practice it was found, that whilst the spaces between these groynes afforded a locality for the deposit of the alluvial soil held in suspension, their action was also to produce a deepening of the main channel of the bed of the river at a much less cost, than by the construction of parallel rubble walls. In fact, the latter should not be built until the groynes had completed their work of raising the acquired land between them, to the level of the bed on which the rubble walls were to be placed.

By adopting these means, there was scarcely a river whose navigable capacity might not be greatly increased, without any excessive outlay; aiding, at the same time, the general drainage of the district, which it was remarked had been lamentably neglected in many of the schemes promulgated for the improvement of rivers.

NOVEMBER 16.

Discussion of Mr. W. A. Brooks' paper "On the Improvement of Tidal Navigations and Drainages."

It was contended that the use of groynes was advisable, as a means for the regulation of the sectional area of the channel, which could only be accurately defined by practical experience. In some cases it would be better to combine them with training walls, on opposite sides of the river. It was not considered that two classes sufficed to distinguish the differences existing between rivers, and that their several characteristics and circumstances must be minutely studied, to determine the mode of treatment. The Wye and the Avon were quoted as rapidly rising rivers, and yet being without bars at their mouths;—to which it was replied, that those streams were not cases in point; that they were mere tributaries, whose mouths were traversed and swept clear by the rapid current of the Severn; and that this latter river illustrated the position assumed, as there was a great loss of

tidal range between Beachley and Framilode, the channel wandering through a range of shoals.

The successful improvements executed at the entrance of Newhaven harbour, by Mr. Stevens, were alluded to.

The treatment of the Dee by groynes, and the Clyde by training walls, was examined, and it was argued that the inconveniences experienced in the former case, from the washing out of deep pools at the points of the groynes, must be attributed to the injudicious extension of those structures, whence the navigation was too violently contracted, the freshes flowing over them, and removing the deposit from between them. Rennie's report on the Clyde, in 1807, showed, that the irregularity of depth at the points of the groynes previously erected by Golborne, was not anywhere 12 inches more than elsewhere in the channel. With reference to the wide expanse or "pouch" form of the Mersey, above Liverpool, which it was urged was of utility in scouring the bar on the ebb, it was contended, that the main body of water would pass off with the early ebb, without producing any beneficial effect; and it was shown, that in that part the loss of tidal range was considerable, from the great expanse covered at high water, but which was shoal at low water.

The improvements of the Thames, by the removal of the shoals and the construction of training walls, were described, and it was suggested, that it might be beneficial to use groynes in the bays which had produced the shoals now in course of removal.

Fully admitting the impossibility of generalizing in river engineering, it was still urged that there was more similarity between cases than was generally understood, and attention was directed to the inevitable effect arising from the conflicting action between the ebb and flood-tides at the mouths of rivers, having a rapid rise of their low-water surface near their mouths, which invariably produced bars.

It was suggested that the treatment of some special river should be submitted to the Institution, in order to afford an opportunity for a continuation of the discussion of this interesting topic.

After the meeting, Mr. Doull, jun., exhibited a model of, and described a system, proposed by Mr. James Forbes, for lowering and raising ships' boats, and also the construction of a cylindrical ship life-boat, which latter, it was contended, approached nearer than any other construction, the qualities considered requisite for a boat of that class.

The cylindrical life-boat was 30 feet long, 8 feet wide, and 2 feet deep—would carry with ease sixty persons, with provisions for a week in the air-tight seats—could not be upset or swamped—could be pulled either end foremost—was steered with an oar—had extra buoyancy in water-tight compartments, and was so constructed, that a hole might be knocked into one or more divisions without danger to the whole—was fully stowed with masts, sails, oars, and everything complete, so as to be always ready for use on any sudden emergency.

When folded up, it was perfectly cylindrical, and, on reaching the water, opened out, and could in a minute be made a stiff boat; and the dimensions could be modified to suit any vessel.

The apparatus for lowering the boats consisted of two davits, with tubular stems, down which the ropes passed, through sockets in the bulwarks, to a drum, on which they were coiled so as to be easily wound up by a wheel and pinion, with the exercise of very little power, and in lowering, a friction-break could be used with great advantage. By this means the boat would swing out very easily, as the davits could turn entirely round; and it would be nearly impossible that a boat could be swamped in the heaviest sea, or under circumstances of the greatest difficulty. The cylindrical form, and its lightness of construction, would enable a boat of this sort to be put over the bulwarks by six men, without tackle of any kind, and by merely cutting a lashing when in the water, it would fall open, when all the stores, &c., would be found made fast within, and ready for use.

APRIL 26, 1853.

"Observations on Salt Water, and its application to the Generation of Steam," by Mr. J. B. Huntington.

MAY 3.

"Description of the Chesil Bank, Portland," by Mr. J. Coode.

MAY 10.

The evening was devoted to the discussion of Mr. Coode's paper.

MAY 17.

"On the Caloric Engine," by Mr. C. Manby.

"On the Principle of the Caloric or Hot-Air Engine," by Mr. J. Leslie.

"On the Conversion of Heat into Mechanical Effect," by Mr. C. W. Siemens.

ROYAL SCOTTISH SOCIETY OF ARTS.

APRIL 25, 1853.

"On a Method of Communication between the Guards and Engine Driver of a Railway Train, available also for Passengers," by the Rev. Wm. Mitchell, Raefield, Portobello.

"On a New Plan of a Railway Signal, and of Communication between the Engine Driver and Guards," by Mr. Daniel Erskine, Engineer, Musselburgh.

"On Railway Inclines, and on the Improvement of the Locomotive Engine, for enabling it to ascend Steep Inclines," by J. Stewart Hepburn, Esq., of Colquhalzie.

"New Designs for Iron Roofs of great clear span, with the Results of Calculations made with a view to compare these with the best forms at present in use," by Robert Henry Bow, Esq., C.E., Edinburgh.

"Method of Escape from a Ship in Distress, particularly for Females and Children," by Mr. Alex. M'Coll, Auchtermuchty.

ON BOILERS AND BOILER EXPLOSIONS.

By W. FAIRBAIRN, Esq., F.R.S.*

Various notions are entertained as to the causes of boiler explosions, and scientific men are not always agreed as to whether they arise from excessive pressure due to the accumulation of heat, or to some other cause, such as the explosion of hydrogen gas, generated by the decomposition of water suddenly thrown on heated plates, of which we have an exceedingly indefinite conception. That of the decomposition of water is, I believe, a somewhat prevalent opinion, but I apprehend it cannot be the invariable cause, inasmuch as in that case we must assume the boiler to be nearly empty of water, and the plates over the furnace red hot.

It is not unreasonable to suppose, that a force of such sudden origin, and so immediate and destructive in its effects, should suggest the presence of an explosive mixture; but I think it will be difficult, if not impossible, to account for the accumulation of a sufficient quantity of hydrogen without the presence of oxygen and other gases, in their due proportions, to form an explosive compound. Now, as these equivalents cannot be generated all at once by the simple decomposition of water (admitting for the moment that the water is decomposed), we must look for some other cause for the fatal and destructive accidents which, of late years, have been so prevalent.

In treating of this subject, I hope to show not only what are the probable causes of explosion, but, what appears equally important, what are not the causes. So many theories (some of them exceedingly problematical) have been brought forward on the occasion of disastrous explosions, that it requires the utmost care and attention to circumstances before they are generally admitted. To acquire satisfactory evidence as to the precise condition of the boiler and furnaces before an explosion is next to impossible, as most frequently the parties in charge, and from whose mismanagement and neglect we may, in many cases, date the origin of the occurrence, are the first to become the victims of their own indiscretion, and we can only judge from the havoc and devastation that ensues as to the immediate cause of the event.

From this it follows that, in many of the explosions on record, few, if any, of the real circumstances of the case are made known, and we are left to draw conclusions from the appearances of the ruptured parts, and the terrific consequences which too frequently follow as a result. This want of evidence as to the precise condition of a boiler, with all its valves and mountings, preceding an explosion, is much to be regretted, as it causes a degree of mystery to surround the whole transaction; and the vague and sometimes inaccurate testimony of witnesses, but too often baffles all attempts at research, and creates additional cause of alarm to all those exposed to the occurrence of similar dangers.

In the discussion of this subject, I shall, however, endeavour to trace, from a number of examples in which I have been personally engaged, and from others which have come to my knowledge, the causes which have led to the disastrous effects.

In my attempts to ascertain facts by a course of reasoning which I shall have to follow in this investigation, I could wish it to be understood that it is not my intention to raise doubts and fears in the public mind, calculated to arrest the progress of commercial enterprise, or to cripple the energies of mechanical skill. On the contrary, I am most anxious to promote the advancement of the useful arts, to increase our confidence in the application of increased pressure, and to secure, within moderate bounds, the economical and useful employment of one of the most powerful agents ever known in the history of practical science. My object in this inquiry will, therefore, be to enlarge our sphere of action by a more comprehensive knowledge of the subject on which it treats; to induce greater caution along with improved construction; and to insure confidence in all those requirements essential to the public security.

For the attainment of these objects, it will be necessary to divide the subject into the following heads:—

- 1st, Boiler explosions arising from accumulated internal pressure;
- 2d, Explosions from deficiency of water;
- 3d, Explosions produced from collapse;
- 4th, Explosions from defective construction;
- 5th, Explosions arising from mismanagement or ignorance; and
- 6th, The remedies applicable for the prevention of these accidents.

1st, *Boiler explosions arising from accumulated internal pressure.*—In nine cases out of ten, a continuous increasing pressure of steam, without the means of escape, is probably the immediate cause of explosion; in some instances it arises from deficiency of water, but accidents of this kind are comparatively few in number, as we often find, in tracing the causes, that they have their origin in undue pressure, emanating from progressive accumulation of steam of great force and intensity. Let us take an example—to some of which I am able to refer—and we shall find that a boiler, under the influences of a furnace in active combustion (as the recipient of heat), will generate an immense quantity of steam, and unless this is carried off by the safety-valve, or the usual channels when generated, the greatest danger may be apprehended by the continuous increase of pressure that is taking place within the boiler. Suppose that, from some cause, the steam thus accumulated does not escape with the same rapidity with which it is generated; that the safety-valves are either inadequate to the full discharge of the surplus steam, or that they are entirely inoperative, which is sometimes the case, and we have at once the clue to the injurious consequences, which, as a matter of fact, are sure to follow. The event may be procrastinated, and repeated trials of the antagonist forces from within, and the resistance of the plates from without, may occur without any apparent danger; but these experiments, often repeated, will at length

injure the resisting powers of the material, and the ultimatum will be the arrival of the fatal moment, when the balance of the two forces is destroyed, and explosion ensues. How very often do we find this to be the true cause of accidents arising from extreme internal pressure, and how very easily these accidents might be avoided by the attachment of proper safety-valves to allow the steam to escape, and relieve the boiler of those severe trials which ultimately lead to destruction! If a boiler, whose generative power be equal to 100, be worked at a pressure of 10 lbs. on the square inch, the area of the safety-valves should also be equal to 100, in order to prevent a continuous increase of pressure; or in case of the adhesion of any of the valves, it is desirable that their areas should, collectively, be equal to 100. If two or more valves are used, 100 or 120 would then be the measure of outlet. Under these precautions, and a boiler so constructed, the risk of accident is greatly diminished; and provided one of the valves is kept in working order, beyond the reach of interference by the engineer, or any other person, we may venture to assume that the means of escape are at hand, irrespective of the temporary stoppage of the usual channels for carrying off the steam.

So many accidents have occurred from this cause—the defective state of the safety-valves—that I must request attention whilst I enumerate a few of the most prominent cases that have come before me. In the year 1845, a tremendous explosion took place at a cotton-mill in Bolton. The boilers, three in number, were situated under the mill, and from unequal capacity in the safety-valves, and even those imperfect, as they were probably fast, a terrific explosion of the weakest boiler took place, which tore up the plates along the bottom, and the steam having no outlet at the top, not only burst out the end next the furnace, demolishing the building in that direction, but tearing up the top on the opposite side, the boiler was projected upwards in an oblique direction, carrying the floors, walls, and every other obstruction before it; ultimately it lodged itself across the railway at some distance from the building. Looking at the disastrous consequences of this accident, and the number of persons—from sixteen to eighteen—who lost their lives on the occasion, it became a subject of deep interest to the community that a close investigation should immediately be instituted, and a recommendation followed, that every precaution should be used in the construction as well as the management of boilers.

The next fatal occurrence on record in this district was a boiler at Ashton-under-Lyne, which exploded under similar circumstances, namely, from excessive interior pressure, when four or five lives were lost; and again, at Hyde, where a similar accident occurred from the same cause, which was afterwards traced to the insane act of the stoker or engineer, who prevented all means for the steam to escape by tying down the safety-valve.

There was a boiler exploded at Malaga, in Spain, some years since, and my reason for noticing it in this place is to show, that explosions may be apprehended from other causes than those enumerated in the divisions of this inquiry, and that is *incrustation*. Dr. Ritterbrandt says, in a paper read before the Institution of Civil Engineers, by an eminent chemist, Mr. West, "that a sudden evolution of steam, under circumstances of incrustation, is no uncommon occurrence." In several instances I have known this to be the case, particularly in marine boilers, where the incrustation from salt water becomes a serious grievance, either as regards the duration of the boiler, or the economy of fuel.

If it were supposed, as Dr. Ritterbrandt observes, that the boiler was incrustated to the extent of half an inch, it would at once be seen that nothing was more easy than to heat the boiler strongly, even to a red heat, without the immediate contact of water. Under these circumstances, the hardened deposits being firmly attached to the plates, and forming an imperfect conductor of heat, would greatly increase the temperature of the iron; and the great difference of temperature thus induced between the material, and the greater expansibility of the iron, would cause the incrustation to separate from the plates, and the water rushing in between them would generate a considerable charge of highly elastic steam, and thus endanger the security of the boiler.

These phenomena were singularly exemplified in the Malaga explosion, which is thus described by Mr. Hick:—"I have ascertained that a very thick incrustation of salt was found on the lower part of the boiler, immediately over the fire, and, so far as it extended, the plates appear to have been red hot, thereby much weakened, and hence the explosion. The ordinary working pressure of the boiler is 130 lbs. per square inch, and perhaps at the time of the explosion very much above that pressure, as there was only one small safety-valve of two and a half inches diameter. The boiler was only two feet six inches diameter, and twenty feet long."

Incrustation, exclusive of being dangerous, is attended with great expense and injury to the boiler by its removal. In the case of the Transatlantic, Oriental, or other long sea-going vessels—even after the use of brine-pumps, blowing out, &c.—a very large amount of incrustation is formed, and considerable sums of money are expended each voyage to remove it.

Other explosions, of a more recent date, are those which occurred at Bradford and Halifax. They are still fresh in the recollection of the public mind, and are so well known as not to require notice in this place.

I cannot, however, leave this part of the subject without reverting to an accident which occurred on the Lancashire and Yorkshire Railway, which had its origin in the same cause—excessive internal pressure. This accident is the more peculiar, as it led to a long mathematical disquisition as to the nature of the forces which produced results at once curious and interesting. The conclusions which I arrived at, although *practically right*, were, however, considered by some *mathematically wrong*, as they were firmly combated by several eminent mathematicians; and notwithstanding the number of algebraic formulas, and the learned discussions of my friends on that occasion, I have been unable to change the opinions I then formed to others more conclusive.

* See page 115, Vol. IV.

The accident here alluded to occurred to the "Irk" locomotive engine, which in February, 1845, blew up, and killed the driver, stoker, and another person who was standing near the spot at the time. A great difference of opinion as to the cause of this accident was prevalent in the minds of those who witnessed the explosion, some attributing it to a crack in the copper fire-box, and others to the weakness of the stays over the top—neither of these opinions were, however, correct, as it was afterwards demonstrated that the material was not only entirely free from cracks and flaws, but the stays were proved sufficient to resist a pressure of 150 to 200 lbs. on the square inch. The true cause was afterwards ascertained to arise from the fastening down of the safety-valve of the engine (an active fire being in operation under the boiler at the time), which was under the shed, with the steam up, ready to start with the early morning train.

The effect of this was the forcing down of the top of the copper fire-box upon the blazing embers of the furnace, which, acting upon the principle of the rocket, elevated the boiler and engine, of 20 tons weight, to a height of 30 feet, which, in its ascent, made a somerset in the air, passed through the roof of the shed, and ultimately landed at a distance of 60 yards from its original position. The question which excited most interest, was the absolute force required to fracture the fire-box, its peculiar properties when once liberated, and the elastic or continuous powers in operation, which forced the engine from its place to an elevation of 30 feet from the position on which it stood. An elaborate mathematical discussion ensued, relative to the nature of these forces, which ended in the opinion that a pressure sufficient to rupture the fire-box, was, by its continuous action, sufficient to elevate the boiler, and produce the results which followed. Another reason was assigned, namely, that an accumulated force of elastic vapour at a high temperature, with no outlet through the valves, having suddenly burst upon the glowing embers of the furnace, would charge the products of combustion with their equivalents of oxygen, and hence explosion followed. Whether one or both of these two causes were in operation is probably difficult to determine; at all events, we have in many instances precisely the same results produced from similar causes, and unless greater precaution is used in the prevention of excessive pressure, we may naturally expect a repetition of the same fatal results.

The preventives against accidents of this kind are well-constructed boilers of the strongest form, and duly proportioned safety-valves, one under the immediate control of the engineer, and the other, as a reserve, under the keeping of some competent authority.

2nd. Explosions from deficiency of water.

This division of the subject requires the utmost care and attention, as the circumstance of boilers being short of water is no unusual occurrence. Imminent danger frequently arises from this cause, and it cannot be too forcibly impressed upon the minds of engineers, that there is no part of the apparatus which constitutes the mountings of a boiler which require greater attention—probably the safety-valves not excepted—than that which supplies it with water. A well-constructed pump and self-acting feeders—when boilers are worked at a low pressure—are indispensable; and where the latter cannot be applied, the glass tubular gauge steam and water cocks must have more than ordinary attention.

In a properly-constructed boiler, every part of the metal exposed to the direct action of the fire should be in immediate contact with the water, and when proper provision is made to maintain the water at a uniform height and depth above the plates, accidents can never occur from this cause.

Should the water, however, get low from defects in the pump, or any stoppage of the regulating feed-valves, and the plates over the furnace become red hot, we then risk the hursting of the boiler, even at the ordinary working pressure. We have no occasion, under such circumstances, to search for another cause, from the fact that the material when raised to a red heat has lost about five-sixths of its strength, and a force of less than one-sixth will be found amply sufficient to bear down the plates directly upon the fire, or to burst the boiler.

When a boiler becomes short of water, the first, and perhaps the most natural, action is, to run to the feed-valve, and pull it wide open. This certainly remedies the deficiency, but increases the danger, by suddenly pouring upon the incandescent plates a large body of water, which, coming in contact with a reservoir of intense heat, is calculated to produce highly-elastic steam. This has been hitherto controverted by several eminent chemists and philosophers; but I make no doubt such is the case, unless the pressure has forced the plates into a concave shape, which, for a time, would retard the evaporation of the water when suddenly thrown upon them. Some curious experimental facts have been elicited on this subject, and those of M. Boutigny and Professor Bowman, of King's College, London, show that a small quantity of water projected upon a hot plate does not touch it; that it forms itself into a globule, surrounded by a thin film, and rolls about upon the plate without the least appearance of evaporation. A repulsive action takes place, and these phenomena are explained upon the supposition that the spheroid has a perfectly reflecting surface, and consequently the heat of the incandescent plate is reflected back upon it. What is, however, the most extraordinary in these experiments is the fact, that the globule, whilst rolling upon a red-hot plate, never exceeds a temperature of about 204° of Fahrenheit; and, in order to produce ebullition, it is necessary to cool the plate until the water begins to boil, when it is rapidly dissipated in steam.

The experiments by the committee of the Franklin Institute on this subject, give some interesting and useful results. That committee found that the temperature of clean iron, at which it vaporized drops of water, was 334° Fahrenheit. The development of a repulsive force, which I have endeavoured to

describe, was, however, so rapid above that temperature, that drops which required but one second of time to disappear at the temperature of maximum vaporization, required 152 seconds when the metal was heated to 395° of Fahrenheit. The committee goes on to state that—"One ounce of water introduced into an iron bowl three-sixteenths of an inch thick, and supplied with heat by an oil-bath at the temperature of 546°, was vaporized in fifteen seconds, while at the initial temperature of 507°, that of the most rapid evaporation was thirteen seconds."

The cooling effect of the metal is here strikingly exemplified by the increased rapidity of the evaporation, which, at a reduced temperature of 38°, is effected in thirteen instead of fifteen seconds.

This does not, however, hold good in every case, as an increased quantity of water, say from one-eighth of an ounce to two ounces, thrown upon heated plates, raised the temperature of its vaporation from 460° to 600° Fahrenheit; thus clearly showing that the time required for the generation of explosive steam, under these circumstances, is attended with danger, and it may be doubted whether the ordinary safety-valves may not be wholly inadequate for its escape.

Numerous examples may be quoted to show that explosions from deficiency of water, although less frequent than those arising from undue pressure, are by no means uncommon; they are, nevertheless, comparatively fewer in number, and the preventatives are good pumps, self-acting feeders (when they can be applied), and all those conveniences, such as water-cocks, water-gauges, floats, alarms, and other indicators of the loss and reduction of water in the boiler.

MONTHLY NOTES.

BURN'S ROLLER COTTON GIN.—Mr. Burn's original arrangement of roller gin, for seeding and cleansing cotton, has met with some discussion in our earlier pages.* The sketch now presented embodies the inventor's latest improvements. It con-

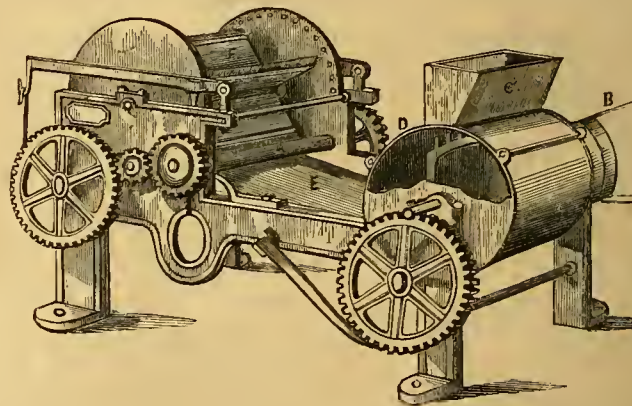

sists of a pair of 18-inch smooth metal rollers, A, weighted in the usual manner by a pair of levers, and driven at a high speed by gearing in connection with the band, B. The seed cotton is fed into the machine by the hopper, C, and cylinder, D, to a card-cloth, E, which carries the cotton right up to the rollers. In passing through these rollers at a rapid rate, the seeds are cleared off it without injury to the staple, the clean cotton being carried away by the brush-fan, F, whilst the seed falls from the card-cloth, and collects under the machine. The weight on the rollers is of course adjusted to suit the character of the cotton to be cleaned. If the cotton is a rough woolly kind, the inventor hangs about 7 lbs. on the levers of the machines he makes; but smooth black seed cotton does with less weight. Before being ginned, seed cotton should be well dried, by spreading it in the sun; and it is of the utmost consequence that it should be kept from dew and moisture, either by storing it in sheds, or covering it by matting during the night, that the seed may be hard. Mr. Burn states, that if his machine is worked by manual labour, its rate can hardly ever be too great, as it gives out its best effect at a high rate. It turns out a very fine staple of the class of cotton required by the Manchester spinners for spinning fine numbers. This cotton is the produce of the black seed, and is the same as that grown at Port-Natal and Moreton Bay, Australia—the largest supply, however, being derived from America. The material in use for testing the machines is imported from Charleston, costing 2d. per lb., two-thirds of the mass being seed, and of no value, but for manure. The rest is clean cotton, worth from 9d. to 1s. 6d. per lb.

SCIENTIFIC OBSERVATIONS AT SEA.—Lord Wrottesley has just effectively argued in the House of Lords, on the subject and with the same views which we briefly expressed in August last, in discussing Professor Smyth's "Meteorological and Astronomical Notices," in reference to the making use of the vast number of nautical observations lying dormant at our service. It appears that a correspondence has been going on between the British and United States Governments, as to a comprehensive scheme for improving the art of navigation, the Americans having most praiseworthy taken the initiative in this very important movement, by begging the co-operation of our Government towards the development of the scheme. The Royal Society was at once referred to for its opinion; and hence Lord Wrottesley,

as an active member, and an indefatigable labourer in the ranks of science, has spoken out upon the subject in the House of Peers. To go a little further back and deeper into the question, we may state that, in 1842, it occurred to Lieutenant Maury, the director of the National Observatory at Washington, that the masters of American vessels would be able to furnish valuable contributions to the stock of scientific knowledge, by noting in their log-books, in addition to the usual entries, all phenomena which they might observe at sea. The object of this undertaking was not only to augment, for the benefit of commerce and navigation, the general stock of knowledge with regard to the winds and currents of the sea, but to obtain the means of investigating the laws of atmospherical and oceanic circulation, and advancing the science of meteorology generally. A scheme for taking these observations was submitted by Lieutenant Maury to the Bureau of Ordnance and Hydrography, and approved of; and an account of the mode of procedure, with some of the results which had flowed from it, were given in a letter addressed by the secretary of the Royal Society to the Government. Detailed instructions were given to all American shipmasters upon clearing from the Custom-house, accompanied by a request that they would transmit to the proper office, on their return from their voyages, copies of their logs, as far as related to these observations, with a view to their being examined, discussed, and embodied in charts of the winds and currents, and in the compilation of sailing directions to every part of the globe. For a long time these instructions were, to a great extent, unheeded; but the publication, in 1848, of a few observations, which tended to show the existence of shorter routes to Rio and other South American ports than had hitherto been followed, satisfied the more intelligent shipmasters that there really was something in the scheme. Since that time, the captain of nearly every American ship has given attention to the subject. At the present time, there are nearly a thousand masters of ships engaged in making these observations, and they receive gratis in return the charts of the winds and currents, and the sailing directions which are founded upon them, corrected up to the latest period. During the short period the system has been in operation, the results to which it has led have proved of great importance to the interests of navigation and commerce. The routes to many of the most frequented ports in different parts of the globe have been materially shortened—that to San Francisco, in California, by nearly one-third. A system of north-westerly monsoons in the equatorial regions of the Atlantic, and on the west coast of America, has been discovered; a vibratory motion of the trade-wind zones, and with their belts of calms and their limits for every month of the year, has been determined; the course, bifurcations, limits, and other phenomena of the great Gulf Stream, have been more accurately defined; and the existence of almost equally remarkable systems of currents in the Indian Ocean, on the coast of China, and on the north-western coast of America, and elsewhere, have been ascertained.

The noble Lord very properly remarked, on the present occasion, that "nothing less than a great number of observations will suffice to make men of science masters of the subject," and strongly urged the necessity of our combining to forward Lieutenant Maury's most excellent system. Earl Granville, and Lords Colchester and Montague, severally spoke on the subject, which "dropped," after a statement from Earl Granville that the Government claimed the right to see that the money granted for such purposes was judiciously expended, and therefore they had abstained from granting aid to scientific investigations, which might be more fitly carried on by private means. So far, therefore, Lord Wrottesley can scarcely be said to have taken anything by his motion, although the undertaking which he has espoused is exactly such a one as ought to be conducted by the Government, for individual attempts must ever be isolated, and therefore useless.

THE ENGLISH AND BELGIAN SUBMARINE TELEGRAPH.—Great Britain is now additionally linked to the European Continent. At 20 minutes before 1 p.m., on the 6th of May, 1853, a practical announcement was made that Dover and Middlekerke were united by an invisible telegraphic line, and that the *European* and American Submarine Telegraph Company had thereby furnished a means of instantaneous communication between England and Belgium. The actual line which has been laid down, was made by Messrs. Newall of Gateshead. It consists of six copper wires, insulated, by the Gutta Percha Company, with a double covering of the very remarkable material which the Wbarf Road Works have so successfully and so universally introduced. The gutta percha, laid into a rope, is served with spun yarn, and then covered over with twelve iron wires. This gives a cable of greater strength than that of a first-rate man-of-war, being capable of standing a strain of 50 tons. When coiled in the hold of the *William Hutt* screw steamer, which took it across channel, the mass was 51 feet in external diameter, 28 feet inside the coil, and 4 feet 6 inches high. Its length is 70 miles; weight, 500 tons; and cost, £33,000. With the aid of some experienced naval men from the Government, the laying down was most successfully accomplished on the day we have mentioned—the proceedings being conducted after a fashion apparently so matter-of-fact, that the work might almost be looked upon as a common and well-practised affair. The only peculiar precaution of the occasion, was the carrying the compass on board a separate tug, which vessel also kept the cable steamer steady on her course, by obviating the difficulties of steering the larger vessel. At one end, the line is laid into a case in the cliff at St. Margaret's, South Foreland. At Middlekerke, on the Belgian shore, it is passed into a coast-guard hut. Thus London and Belgium are now within speaking distance.

MILK AS A MANUFACTURING INGREDIENT.—Milk now possesses other offices besides the production of butter and cheese, and the flavouring of tea. It has made its way into the textile factories, and has become a valuable adjunct in the hands of the calico-printer and the woollen manufacturer. In the class of pigment-printing work, which is indeed a species of painting, the colours are laid on the face of the goods in an insoluble condition, so as to present a full, brilliant face. As a vehicle for effecting this process of decoration, the insoluble albumen obtained from eggs was always used, until Mr. Patison, of Glasgow, found a more economical substitute in milk. For this purpose, buttermilk is now bought up, in large quantities, from the farmers; and the required insoluble matter is obtained from it at a price far below that of the egg albumen. This matter the patentee has called "lactarine." A second application of the same article, milk, has just been developed, by causes arising out of the recent high price of olive oil. Oil having risen from £40 to £70 a ton, the woollen manufacturers are now using the high-priced article, mixed with milk. This mixture is said to answer much better than oil alone, the animal fat contained in the globules of the milk apparently furnishing an element of more powerful effect upon the woollen fibres, than the pure vegetable oil alone.

MARTIN'S REVOLVING TURNIP HOE.—Our perspective sketch of this most efficient implement will materially aid the reader's comprehension of our earlier unillustrated description.* It will cut or hoe out turnips for being singied, as is now done by hand-hoeing, on either flat or ridge; whilst it can work two or more rows

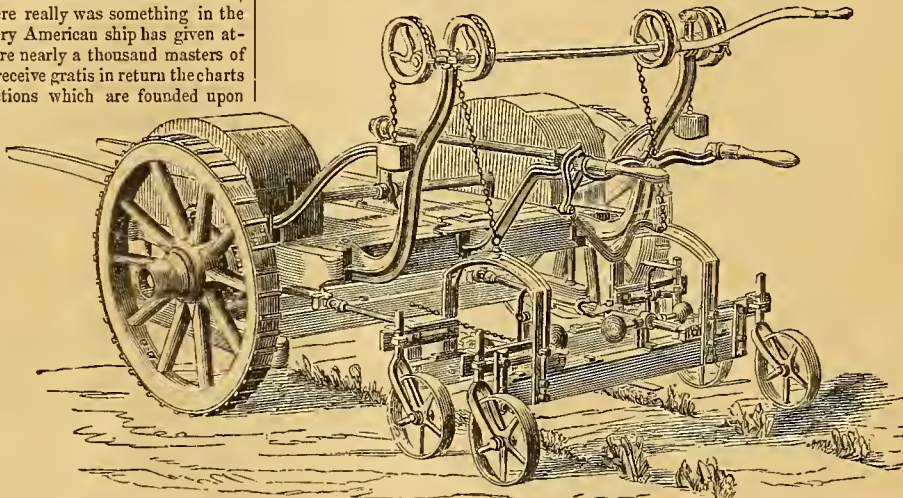

at once, and to any width. The plants may also be left at any distance apart. A man and boy and one horse can do ten or twelve acres a day on twenty-seven inch work—cutting the land to any required depth.

INDUSTRIAL EXHIBITIONS, DUBLIN, NEW YORK, EDINBURGH, AND PARIS.—Whilst the Irish Industrial Exhibition is putting forth its beauties, and being toned down to the condition of a universal school, and whilst the American collection is rapidly following, we have notes of preparation of an Edinburgh Exhibition in 1854, and actual official announcements of a Parisian one in 1855. In reference to this last, the following has just been issued by the Board of Trade Department of Science and Art:—"The Lords of the Committee of Privy Council for Trade have received a communication from the Secretary of State for Foreign Affairs, transmitting a copy of a letter from Count Walewski, the French Ambassador at the Court of London, in which it is announced that, by a decree of the 8th of March last, his Majesty the Emperor has ordered that a Universal Exhibition of Agricultural and Industrial Products shall take place in Paris on the 1st of May, 1855. The French Ambassador states, that exhibitors of those countries who answer to this appeal will meet with every requisite facility, both as regards the Customs' regulations, and the reception, arrangement, and security of their products, in the Palace of Industry. A later decree, which will be communicated without delay, will determine and specify the conditions of the Universal Exhibition, the rules under which goods will be exhibited, and the different kinds of products which will be admitted. Count Walewski expresses a hope, on behalf of the Government of his Imperial Majesty, that the British Government will do all in their power to direct the attention of British manufacturers to the intended Exhibition of 1855, and that they will answer to the invitation which is now addressed to them with the same ardour as the French manufacturers responded to the invitation of England in 1851. In accordance with the request of the Earl of Clarendon, my Lords desire to give the widest publicity to this measure, in order that no effort may be spared in furtherance of the intentions of the Emperor of the French as regards the Exhibition of British agriculture and industry.—HENRY COLE and LYON PLAYFAIR (Joint Secretaries), Marlborough-house, 10th May, 1853."

NORTON'S PERCUSSION BLASTING CARTRIDGE.—Captain Norton has been most successful in the application of his new "percussion cartridge," for blasting the roots of large trees, which withstood all attempts at blowing up by a fusee and tamping. He goes to work in this way:—A triangle is made of three tall larch spars placed over the root to be blasted, a hole being bored by an auger an inch and a quarter in diameter into the most "gnarled and unweedgeable" part of the root; a gauge rimer is good to use after the auger, as it clears away the rough interior, and admits the cartridge freely. About three inches deeper than the centre, a plug of iron of the same diameter of the auger, and an inch and a half long, or a small round stone, is forced into the bottom of the hole, so as to prove a *solid* foundation; this plug and steel pillar being almost always found at the bottom of the riven block. The cartridge, with a percussion-cap on each end of its steel pillar, is then dropped in, and rests on the iron foundation; a rammer of iron, of nearly the same diameter as the auger, and about four inches longer than the depth of the hole, so as to project about four inches, is then inserted, and may, or may not, rest on the head of the cartridge. A block of wood, about 60 pounds weight, suspended by a strong cord vertically over the projecting head of the rammer, is then allowed to fall on it, when, by the momentum or blow, the explosion takes place, and in no one instance out of more than a hundred trials has the rammer been blown out, or, as military engineers term it, "gunning" occurred. In one instance the cartridge was made of tin, so as to be waterproof, and when it was inserted, and the rammer placed over it, water was poured in, the explosion was perfect; this was to demonstrate the blasting of rocks under water lying in the way of navigation. The charge of powder in these cartridges is about an ounce of Hall's powder; it is probable that the *fourth* part of the powder used in the present manner of blasting will be found, by *this* method, to be sufficient. Professors of the Royal Queen's College, and many of the students, were present. Captain Norton's ambition is the removing of the forests on the banks of the Amazon, Orinoco, and their tributaries, thus destroying the prolific *wet nurse* of all malaria; also, the forests of Canada, the United States, New Holland, New Zealand, and thus removing the great obstructions to the cultivation of land in all countries; the rousting out of snakes and nuggets in New Holland and California; and for removing large blocks of wood found in hogs, which, on account of their great weight, and the soft nature of the bog, neither cart nor car can be used for removing, but which, when shattered by the cartridge, can be taken away by men, or boys, in small pieces; and the removing of blocks of ice, impeding the navigation of the Arctic seas. In a later experiment, the object was to remove, by one blast, the largest forest tree while standing in a growing state, where timber is so thick and dense, as not only to be valueless and pestiferous, but a great obstruction to the cultivation of the land, as in America and New Holland. Mr. O'Brien, of Castle White, near the Queen's College, Cork, having kindly given Captain Norton permission to operate on a large old poplar tree, three feet in diameter near the root, a hole was bored horizontally within two feet of the ground, and the cartridge and iron bolt (which bolt does the duty of the most perfect tamping) being inserted, a heavy block of wood suspended from a large iron nail, struck into the trunk of the tree, was drawn by a long cord attached to it, about a foot from the projecting head of the bolt, and then let go, so as to strike it like a pendulum or the knocker of a hall door, when the instant explosion rent the trunk of the tree, and caused it to fall by the pull in the direction chalked out for it by a rope attached to an upper branch of the tree. The effect of this percussion cartridge is like that of the rifle percussion shell, the iron bolt acting like the breaching of the shell.

PROVISIONAL PROTECTIONS FOR INVENTIONS

UNDER THE PATENT LAW AMENDMENT ACT.

When the city or town is not mentioned, London is to be understood.

Recorded November 23, 1852.

823. Auguste E. L. Belford, 16 Castle-street, Holborn—Improvements in drying furnaces.—(Communication.)
Recorded February 24, 1853.
465. Charles Flude, Old Kent-road—Improvements in the production of spirit, and in the stills and apparatus employed therein.
Recorded March 8.
584. Samuel C. Lister, Bradford—Improvements in machinery used in washing wool.
Recorded March 12.
625. Nicholas A. E. Millon and Leopold Mouren, Algiers—Certain improvements in the treatment of corn and other grains, and more especially in all that concerns washing, drying, grinding, curing, and preserving them.
Recorded March 16.
656. Edward Nickels, Albany-road, Camberwell—Improvements in preparing lubricating matters.—(Communication.)
Recorded March 18.
672. George R. Lucas, Dronfield—Improvements in the method of raising water and other materials from mines.
Recorded March 22.
698. Samuel McCormick, 14 Fleet-street, Dublin—Improvements in manufacturing screws, bolts, spikes, and rivets, and other similar articles, and in the machinery or apparatus used for such manufacture, parts of which machinery are applicable for forming screw-threads, mouldings, and ornaments on metal.
Recorded March 28.
740. George E. Dering, Lockleys, Hertford—Improvements in preserving or preventing decomposition in vegetable and animal substances and matters.
Recorded March 29.
747. Henry L. Corlett, 106 Summer-hill, Dublin—Improvements in railway waggons.
Recorded April 1.
778. John Smedley, Matlock, Derby—Improvements in machinery or apparatus for opening, cleaning, blowing, or scutching animal wool, cotton, or other fibrous substances or materials.

Recorded April 5.

809. William W. Sleigh—An invention for the production of motive power, which he entitles "the counteracting reaction motive power engine."
811. Edmond S. Stanley, Sloane-street—An improvement in the manufacture of soda ash, or carbonate of soda, from common salt.—(Communication.)
813. John O'Connor, Limerick—An invention for the manufacture of coke from raw peat.
815. Smith Flanders, Wingham, Kent—Certain improvements in the construction of ploughs.
817. William Pidding, Strand—Improvements in the manufacture of woven, textile, or other fabrics, and in the machinery or apparatus connected therewith.
819. Thomas Carr, Chowbent, Lancashire—Improvements in nails and other fastenings, and in the machinery or apparatus employed in the manufacture thereof.
821. William Pidding, Strand—Improvements in the preparation or treatment of twine or other threads, or cuttings of paper or other waste, for the production of useful and ornamental articles.

Recorded April 6.

823. Frederick A. Gatty, Accrington, Lancaster—Improvements in printing or producing colours on textile fabrics.
825. Henry Leachman, 13 Compton-terrace, Islington—Improvements in the manufacture of iron.—(Communication.)
827. William Radford, Buckingham-street, Middlesex—Improvements in the construction of metallic beams or bracings, and metallic sheats or plates, applicable to the building of ships and other structures, where lightness and strength are required.
829. William Johnson, 47 Lincoln's-inn-fields, and Glasgow—Improvements in the manufacture of safety paper.—(Communication.)

Recorded April 7.

831. John F. Heather, Woolwich—Invention of a pneumometer for determining the densities or specific gravities of gases.
833. William Morgan, Birmingham—Improvements in paper and cardboard cutting machines.
835. Frederick W. Mowbray, Bradford—Improvements in apparatus used in preparing and combing wool, and other fibrous materials.
837. Edward L. Bryan, Hoxton—Improvements in warming and ventilating rooms and buildings.
839. Robert P. Clark, Lamhton Collieries, Durham—Improvements in machinery for loading and unloading colliers, and other ships and vessels.
841. Leopold J. Green, Leatherhead, Surrey—Improvements in axlcree boxes.
843. William Fuller, Jermyn-street—Improvements in ice pails or apparatus for refrigerating.

Recorded April 8.

844. George F. Goble, 15 Great Fish-street-hill—Improvements in safety valves for steam boilers and gas chambers.
845. William F. Smith, Manchester—An improvement in certain vessels or utensils for heating liquids.
846. William Moseley, 32 Cumberland-terrace, Regent's-park—Invention of a new method of railway traction, to be called a pony railway.
847. George Humphrey, Brighton—An improved self-acting safety valve, for locomotive, marine, and other steam boilers.
848. Alexander S. Braden, High-street, Islington—Improvements in apparatus for roasting coffee, cocoa, and other vegetable matters, and for cooling the same when roasted.
849. Jean J. T. Pratiel, Paris—An improved machine for doubling, twisting, and reeling fibrous substances.
850. Patrick F. Flanagan, Liverpool—Improvements in the manufacture of hats for yachting and general purposes.
851. Henry O. Robison, 43 Moorgate-atreet—Improvements in machinery for crushing sugar canes.
852. George Herbert, Summer-hill, Dartford—Improvements in constructing and mooring light vessels, buoys, and other similar floating bodies.
853. Joshua Farrar, Marsden—Improvements in the treatment of flax, line, grasses, and other fibrous substances.
854. Stephen Taylor, New York—Improved machinery for weaving seamless goods.—(Communication.)

Recorded April 9.

855. George F. Goble, 15 Fish-street-hill—Improvements in machinery to be actuated by water or air.
857. Herbert Taylor, Mark-lane—Improvements in ornamenting surfaces or fabrics applicable to various useful purposes, such as for covers of furniture, imitation tapestry, carpets or hangings.—(Communication.)
858. Adolphe M. A. Iglesia, Russell-place, Fitzroy-square—Improvements in producing ornamental glass surfaces.
859. William P. Cresson, George-street, Portman-square—Improvements in lathea and parts connected therewith, for the purpose of reducing and smoothing the surfaces of certain metal wares.—(Communication.)

Recorded April 11.

860. John B. Gibson, Leicester-square—Improvements in saddlery and harness.
861. John F. Boake, Dublin, and John Reilly, same place—Improvements in signal posts for railways and apparatus connected therewith.
862. Robert B. Ruggles, New Jersey, and Lemuel W. Serrell, New York—Improvements in machinery for beating gold and other laminae of metal.
863. Robert Garrard and John Garrard, Lomau-street, Southwark—Improvements in bonnets.
864. William Urquhart, Lincoln's-inn-fields—Improvements in the manufacture of printers' type, and other articles used in letter-press printing.
865. William R. Palmer, New York—Improvements in the construction and arrangement of machines for the application of horse power, which he designates as "Palmer's improved horse power."
866. William R. Palmer, New York—Improvements in machines for thrashing seeds and grains, and for cleaning them from the straw and chaff after they are thrashed, which he designates as "Palmer's American seed and grain thrasher and winnower."
867. Hugh Donald, Johnstone, Renfrew—Improvements in machinery for cutting and uniting metals.
868. William M. Campbell, Glasgow—Improvements in earthenware kilns.
869. Donald Nicoll, Regent-street—Improvements in garments, and in sewing or uniting the seams of the same.

Recorded April 12.

870. Samuel Russell and Robert M. M. Turk, Sheffield—Improvements in metallic handles for table cutlery, daggers, and such like instruments.
871. Henry Blake, Brighton—Improvements in railway wheels.
872. Richard A. Brooman, 166 Fleet-street—Improvements in grinding and pulverizing gums, gum resins, and other drugs and articles of similar character.—(Communication.)

873. Alexander Turiff, Paisley—Improvements in the prevention of accidents on railways.
874. Henry W. Harman, Northfleet Dockyard—Improvements in steam-engines.
875. James Taylor, Carlisle, Isaac Brown, same place, and John Brown, Oxford-street—Improvements in the manufacture or production of charred peat.
876. Auguste Mondolot, Paris—Improvements in filling vessels with aerated waters, and the apparatus employed therein.—(Communication.)
877. Downes Edwards, Douglas, Isle of Man—Improvements in signal apparatus for railways.
878. Thomas Greenwood, 11 Little Aliee-street, Goodman's-fields—Improvements in evaporating saccharine fluids.
879. Richard G. Pigot, 5 George-street, Greenwich—Improvements in caltraps for military purposes.
880. François F. Verdié, Lorette, France—Certain improvements in welding cast-steel with iron, steel, cast-iron, and other metals.
881. Robert J. Kaye, Bury, Lancaster, and John O. Openshaw, Roachmount, near Bury—Improvements in obtaining motive power by electro-magnetism.
882. Eliza Cunnington, Devizes—Improvements in the decoration of furniture panels and other surfaces.
883. John Smith, Bartholomew-close—An improved mode of suspending carriage bodies.
884. Alfred V. Newton, 66 Chancery-lane—Improvements in steam boilers, and in the mode of supplying the same with water.—(Communication.)

Recorded April 13.

885. Alexander E. D. K. Archer, City-road—Improvements in apparatus for applying metallic capsules.
886. Nathaniel Clayton and Joseph Shuttleworth, Stamp End Ironworks, Lincoln—An improvement in portable and locomotive steam-engines.
887. George Elliot and William Russell, St. Helen's, Lancaster—Improvements in the manufacture of alkali.
888. William Pearce, Arlington-street, Myddelton-square—Improvements in the construction of locomotive engines, parts of which improvements are applicable to other engines.—(Communication.)
889. Thomas Edwards, Birmingham—Improvements in steam-engines.
890. James Noble, Leeds—Improvements in preparing cotton and other fibres.
891. Douglas Hebson, Liverpool—Improvements in working the air-pumps of steam-engines.
892. Francis Burden, Belfast—Improvements in treating rovings for spinning.
893. William R. Bowditch, Wakefield—Improvements in purifying water.
894. James Noble, Leeds—Improvements in preparing cotton and other fibres.
895. Charles Clifford, Inner Temple-lane—Improvements in apparatus for lowering boats evenly, and preventing them filling with water.

Recorded April 14.

896. John Hinks and George Wells, Birmingham—An improvement or improvements in certain kinds of boxes.
897. Thomas L. Preston, Birmingham—An improvement or improvements in cutting out and piercing metals.
898. Constant J. Duméry, Castle-street, Holborn—Improvements in the manufacture of paste and enamel buttons.
900. Charles Lowe, Sheepy Hall, Leicester—Improvements in mills for grinding wheat and other grain.
901. John Chadwick, Manchester, and Thomas Dickins, Middleton—Improvements in the production of raw and thrown silk.
902. John Bethell, Parliament-street—Improvements in the manufacture of flax.
903. William Laycock, Birkenhead—Improvements in the manufacture of metallic and other casks and vessels.
904. Joseph Adamson, Leeds—Improvements in flushing apparatus and in water-closets.
907. Alfred Guy, Upper Rosoman-street—Invention of an improved filter.
908. Charles Green and James Newman, Birmingham—Improvements in the manufacture of wheels.
909. Robert Wyburn, Tannton—Improvements in the construction of easy chairs.
910. William Ogden, Oldham—Certain improvement or improvements applicable to carding-engines, used for carding cotton, wool, and other fibrous materials.
911. William J. T. Jones, Pimlico—Improvements in steam-engine governors.
912. David Zenger, Newcastle-upon-Tyne—Improvements in the treatment of ores and other substances containing metals, to obtain products therefrom, and the apparatus used therein.
913. Alexander Crichton, Liverpool—Improvements in the fitting of bilge pumps and injection cocks of iron steamers and sailing vessels.
914. François M. A. Serruys, Brussels—Improvements in tanning.—(Communication.)
915. Jean B. Maniquet, Paris—Certain improvements in machinery or apparatus for winding, cleaning, doubling, twisting, and spinning silk, cotton, wool, flax, hemp, and other filamentous materials.
916. George Titterton, Margaret-street, Cavendish-square—Improvements in brushes.

Recorded April 15.

917. William Wilkinson, Nottingham—An improvement or improvements in ropes, cords, lines, twines, and mill bandings.
918. William Allen and William Murrell, Pimlico—Improvements in the mode or modes of cleansing bottles or other similar articles.
919. John Lewthwaite, Halifax—Improvements in rollers or mountings for blinds, maps, and other like articles.
920. William E. Newton, 66 Chancery-lane—Improvements in treating refuse silk waste, and in converting it into a valuable product.—(Communication.)
921. Phillip Davis, Whitechapel-road—An improved mode of constructing the breasting to the revolving drums or beaters of thrashing machines.
922. Samuel Bayliss, Old Broad-street—Improvements in consuming or preventing smoke and heating liquids.
924. Jean M. Sonchon, Paris—Improvements in the manufacture and purification of gas for illumination, and certain products therefrom, and in apparatus for that purpose.
925. Joseph Cooke, Birmingham—New or improved machinery for cutting or shaping corks and hungs.
926. George A. Cator, Selby—Improvements in machinery for preparing flax, hemp, and other vegetable fibrous substances, for scutching, or other manufacturing processes.
927. Isaac Simpson, Preston—Improvements in machinery for covering wire, alk, cotton, linen, wool, or any other flexible material, with wire, plate, silk, cotton, liuen, wool, or any other flexible material.
928. Henry Wilks, Rotherham—Improvements in cocks.

Recorded April 18.

930. James Begbie, Haddington—Improvements in the construction of wheeled carriages.
931. Richard F. Stargess, Birmingham—Invention of a new or improved apparatus for making vegetable and other infusions and solutions.
932. Joel Watts, Battersea-fields—Improvements in the construction of pistons of steam and other engines, applicable also to force pumps and lifting pumps.
933. William McNaughton, Aberdeen—Improvements in printing yarns or worsteds for weaving carpets, also in printing carpets, woollen, silk, cotton, and other textile fabrics or fibrous substances.

935. William Fawcett and Francis B. Fawcett, Kidderminster—Certain improvements in the manufacture of carpets.
936. James S. Scarlett, Norwood, Surrey, and William S. Passmore, Brixton—Invention of the application of a certain mineral to lamps, in lieu of cotton or other wicks.
937. Jeau J. Gonin, Paris—Improvements in disengaging silk of its gum.

Recorded April 19.

938. François G. Sicardo, South-street, Finsbury—Invention of a new rotary steam-engine.
939. Thomas Newey, Birmingham—Improvements in fastenings for articles of dress.
941. Lambert A. Beauvain, Upper Charlotte street, Fitzroy square—Improvements in machinery for obtaining wool, silk, and fibres from fabrics, and rendering them suitable to be again employed.
942. John Chatterton, Birmingham—Improvements in coating tubes.
944. John Fuller, Kennington—Improvements in galvanic batteries.
945. Christian Bohringer and Gustavus Clemm, Manuheim and Heilbron, Wurtemberg—Improvements in the manufacture of soda and potash.
946. Thomas Day, Birmingham—Improvement in the manufacture of boots and shoes, whereby great ease is secured to the wearer.
948. Edward Vivian, Torquay, Devon—Improvements in thermometers.
949. Andrew Blair, Maryhill—Improvements in propelling vessels.

Recorded April 20.

950. John Smethurst, Manchester—An improved plan for packing yarn and other materials.
951. Samuel Weight, Cheltenham—Improvements in ventilating mines, sewers, or drains, ships, buildings generally, and other localities.
952. Emile Chapuis, fils, St. Mary Axe—An improved apparatus for the diffusion of light, to be called the "Myriastric Reflector."
953. Henry McEvoy, Birmingham—Certain improvements in the construction and manufacture of door bolts.
954. Thomas C. Foster, Strand—An improved reaping machine.
955. Richard A. Brooman, 166 Fleet-street—Improvements in inhaling tubes.—(Communication.)
956. Richard A. Brooman, Fleet-street—Improvements in reaping and gathering machinery.—(Communication.)
957. Sir William S. Harris, Plymouth—Improvements in lightning conductors for ships and vessels.

Recorded April 21.

958. Anthony Deale, Hampstead-road—Invention of ocean floats, which are designed to save lives and light treasures from shipwreck.
960. Charles Reeves, junior, Birmingham—An improvement or improvements in swords.
962. Henry Carr, East Retford—Certain improvements in the construction of railways.
963. James Petrie, Rochdale—Certain improvements in steam-engines.
964. Philip Harris, Chatham—Certain improvements in fire-arms.
965. William Robjohn, Islington—Improved meter for measuring and indicating the measure of liquids.
966. William H. Johnson, Granville, Massachusetts—Invention of sewing cloth, leather, and other materials.
967. William E. Newton, 66 Chancery-lane—Improvements in machinery for bending wood or other materials.—(Communication.)
968. Thomas F. Finch, Worcester—Improvements in buttons.
969. James Davis, Hemel-Hempstead—Improvements in the manufacture of thrashing machines.
970. William Sager, Seacombe, Chester—Certain improvements in machinery or apparatus for propelling vessels.
971. William Hunter, Glasgow—Improvements in cutting and planing wood and other substances.
972. William Asquith and Joseph Asquith, Leeds—Invention of cleansing, preening, and removing wool flocks, waste, and refuse from the cards, teazles, cylinder, raising gig, and machinery used in the dressing of woollen cloths.
973. William Beard, Cannon-street—Improvements in needles and in the manufacture of the same.
974. Cyprien M. T. du Motay, Paris—Improvements in preparing oils, and in apparatus for burning the same.
975. Jerome A. Drien, Bowden, Chester—Improvements for cutting the pile of velvet, velveteens, and other piled fabrics.

Recorded April 23.

976. Edward O. Aston and George Germaine, Mill-wall—Improvements in compositions for coating wood, metal, and other materials exposed to the action of sea-water or the weather.
978. Thomas Knowles, Newton—Improvements in the machinery or apparatus for picking warps.
979. Frederick J. Wilson, Chelsea—An improved wheelbarrow.
982. James Geddes, Glasgow—Improvements in oars.
983. William Johnson, 47 Lincoln's-inn-fields, and Glasgow—Improvements in machinery for combing wool or other fibrous materials.—(Communication.)
984. James Napier, Partick—Improvements in separating certain metals from their ores and alloys, and for obtaining certain products therefrom.
985. George F. Wilson, Belmont, William H. Hatcher, Old Kent-road, and John Jackson, Southville—Improvements in apparatus for manufacturing moulded candles.
986. Richard Johnson, Manchester—Improvements in machinery or apparatus for drawing wire.

Recorded April 25.

987. Edward O'Connell, Bury, Lancaster—Improvements in the mode or method of feeding infants and invalids, and in apparatus connected therewith.
988. Henry E. Ifoole, Sheffield—Invention of a self-acting speed regulator and safety break for railway carriages.
989. Charles L. Desbordes, Paris—Improvements in instruments for measuring the pressure and temperature of air, steam, and other fluids.
990. John Chatterton, Birmingham—An improvement or improvements in covers for waggons, carts, and other vehicles.
991. Robert Davies, Birmingham—Invention of an agricultural reaping machine.
992. William Tillie, Glasgow, and John Henderson, same place—Improvements in printing shirting fabrics.
993. James Emery, Preston—Improvements in the construction of gigs, dog-carts, and other vehicles.
994. William Johnson, 47 Lincoln's-inn-fields, and Glasgow—Improvements in the means of retarding and stopping railway trains.—(Communication.)
995. Julian Bernard, Guildford-street, Russell-square—Improvements in casting metals, and in moulding or forming other materials.

Recorded April 26.

996. Isaac B. Sheath, Birmingham—Certain improvements in fire-arms.
997. Jacques E. Joffriard, Paris—Certain improvements in machinery or apparatus for washing earths containing gold extracted from the bottoms of rivers or other waters.
998. George K. Geyelin, Camden-town—Improvements in the manufacture of white oxide of zinc.

1001. John Pym, Pimlico—Improvements in building materials.
 1002. Auguste and Jean Le Roy and Eugène Pavy, Paris—Improvements in the production of lace and other fabrics.
 1003. Uriah Scott, Camden-town—Improvements in the manufacture of tubular rods and rings for furniture.
 1004. Moses Poole, Avenue-road, Regent's-park—Improvements in the manufacture of porcelain and like wares.—(Communication.)
Recorded April 27.
 1005. William Johnson, Farnworth—Improvements in machinery for preparing and spinning cotton and other fibrous substances.
 1006. Frederick G. Underhay, Well-street, Gray's-inn-road—Improvements in reaping and mowing machines.
 1007. George F. de Fonville, Marseilles—Invention of a filtering machine, which acts under water, and is applicable to the filtering of all liquids.
 1008. Benoist M. A. Langlois, Paris—Improvements in instruments to be applied to the chimneys of gas burners.—(Partly a communication.)
 1010. John Hetherington, Manchester, and John Dugdale, jun., and Edward Dugdale, Blackburn—Improvements in constructing and applying models or patterns for moulding, preparatory to casting iron, brass, and other metals for various purposes.
 1012. Richard Howson, Manchester—Certain improvements in weavers' harness.—(Communication.)
 1013. John H. Johnson, 47 Lincoln's-inn-fields, and Glasgow—Improvements in apparatus for sustaining bodies in the water.—(Communication.)
 1014. Joseph W. Gale, Woburn-place, Russell-square—Improvements in the permanent way of railways.
 1015. William Johnson, 47 Lincoln's-inn-fields, and Glasgow—Improvements in machinery or apparatus for marking, ruling, or ornamenting surfaces.—(Communication.)
 1016. George Turner, Wandsworth-road, and Robert Holloway, Old Kent-road—Improvements in the manufacture of unfermented bread, which improvements are also applicable to other purposes as a substitute for yeast.
 1017. George Critchley, Cheltenham—An improved apparatus for regulating the heat and supply of water in hot-water apparatus.
 1018. Joseph Palin, Liverpool, and Robert W. Sievier, Upper Holloway—Improvements in distillation, and in apparatus connected therewith, which apparatus is also applicable to other purposes, to which substances are to be treated by the assistance of a vacuum.
 1019. Samuel Groves, Great Marlborough-street, Regent-street—Improvements in pneumatic apparatus for pumping or forcing air.
 1020. James A. Bruce, Coleraine—Certain improvements in the construction of hay racks, and other apparatus or apparatuses to contain fodder for horses and other cattle, and also in the method or methods of fastening horses or other cattle, to prevent their overcasting.
 1021. Thomas Culpin, Greenwich—Improvements in steam boilers and in the appendages thereto.
 1022. Wellington Williams, Gutter-lane—Invention of a new combination of materials suitable for the manufacture of boxes, cases, trays, and other like articles.
 1023. William Reid, University-street—Improvements in apparatus for testing the insulation of electric telegraph wires.
 1024. Richard J. Gatling, Indianapolis, U. S.—An invention for distributing power to machine shops, factories, and other places.
 1025. John F. Kingston, Maryland, U. S.—Improvements in galvanic or voltaic batteries.
 1026. William F. Thomas, Bayswater—Improvements in apparatus for sowing or stitching.
Recorded April 28.
 1028. Joseph Hetherington, Manchester—Certain improvements in reels for reeling or winding yarns.
 1030. Edward Bird, Birmingham—An improvement or improvements in the construction of certain kinds of vehicles.
 1031. James Berry, Harwich, near Bolton, and Thomas Booth, Chorley—Improvements in machinery or apparatus for printing or staining woven fabrics and paper.
 1033. William H. Sitwell, Sydenham—Improvements in projectiles for cannon and firearms.
 1034. Sir John S. Lillie, South-street, Finsbury—Improvements in roads, floors, footways, and other like surfaces.
 1035. William A. Gilbee, Finsbury—Improvements in apparatus for heating.—(Communication.)
 1036. Thomas Revis, Stockwell, Surrey—Improved single seed drilling or dibbling machinery.
Recorded April 29.
 1037. George T. Day, Burghfieldhill, Beaks—Improvements in travelling packages.
 1038. Thomas Pennell, Birmingham—Improvements in the construction of revolving or repeating fire-arms, and in loading the same.
 1039. Charles A. Joubert, Paris, Léon J. Tricas, and Jules C. Kohler, same place—Improved buxks for staves.
 1040. Robert Davison, Mark-lane, and James S. Horrocks, Heaton-Norris—Certain improvements in the means of conveying and distributing, or separating, granular and other substances.
 1041. Thomas C. Banfield, Queen-square—Invention of machinery for cutting or chopping roots, planks, or other similar substances.—(Communication.)
 1042. Thomas C. Banfield, Queen-square—Invention for drying and preserving vegetable or other saccharine plants.—(Communication.)
 1043. Jacques S. Vigoureux, Rheims, France—Certain improvements in the combing of wool and other fibrous materials.
 1044. James Macpherson, Manchester—Certain improvements in looms for weaving.
 1045. Colin Mather, Salford—Improvements in apparatus used in bleaching.
 1046. Henry Withaff, Manchester—Improvements in filters.—(Communication.)
 1047. Oliver P. Drake, Massachusetts—A new or improved apparatus for vaporizing benzole, or other suitable volatile hydro-carbon, and mixing it with atmospheric air, so that the mixture may be burnt for the purposes of illumination or otherwise.
 1048. John Kealy, Oxford-street—Improvements in machinery for mowing.
 1049. James Bristow, Bouverie-street, and Henry Attwood, Blackfriars-road—Improvements in the means of consuming smoke.
Recorded April 30.
 1050. Charles Adams, Lillington-street—Invention of a new arrangement of valves, for the supply of water to and from cisterns and other receptacles, and for a new float-valve.
 1051. Barnabas Barrett, Ipswich—Improvements in the treatment of natural and artificial stone, and of articles composed of porous cements or plaster, for the purpose of hardening and colouring the same.
 1052. John Smith, Ashton, Warwick—An improvement in machines for cutting chaff, straw, gorse, and other similar substances.
 1053. Weston Grimshaw, Moseley, Antrim—Certain improvements in slubbing and roving frames for preparing for spinning cotton, flax, and other fibrous substances.
Recorded May 2.
 1054. John Balmforth, William Balmforth, and Thomas Balmworth, Clayton—Improvements in steam-hammers.

1055. John Smith, Ashton, Warwick—An improved flooring cramp and lifting jack.
 1057. Henry C. Jennings, Great Tower-street—Improvements in the manufacture of soap.
 1058. John F. Kingston, Carrol, Maryland, U. S.—Improvements in reaping and mowing machinery.
 1059. Edwin Heywood, Glashburn, near Keighley—Improvements in apparatus for actuating and regulating the throttle valves of steam-engines.
 1060. James Reeves, Bridgewater-gardens—Improved machinery for forging, stamping, crushing, or otherwise treating metals, ores, and other similar materials.
 1061. George Morton, Bolton, and William H. Langshaw, same place—Certain improvements in stretching, dressing, and finishing cotton and linen yarns or threads, and in the machinery or apparatus connected therewith.
 1062. Auguste E. L. Bellford, Holborn—Improvements in the extraction and manufacture of sugar and of saccharine matters.—(Communication.)
 1063. Daniel Reading, Minories—Improvements in bearings for axles, and in axle-boxes and bushes.
 1064. François Monfrant, Haymarket—Improvements in lubricating materials.—(Communication.)
 1065. Auguste E. L. Bellford, Holborn—Improvements in sawing machines for slitting or re-sawing plank and other timber, by means of circular saws.—(Communication.)
 1066. Ambrose M. C. C. Faure, Holborn—Certain improvements in the manufacture of geographic and other maps.
 1067. Christian Radunsky, Cockspar-street—Certain improvements in electro-voltaic apparatus.—(Communication.)
 1068. Mark Newton, Tottenham—Certain improvements in the construction of carriages, and in the means of preventing the overturning of the same when horses take flight.—(Communication.)
 1069. Joseph T. Wood, Strand—Improvements in the manufacture of boxes, such as have been hitherto made of pasteboard.
 1070. Honoré Mane, Strand—Improvements in steam-engines.
Recorded May 3.
 1071. Thomas Claridge, Bilston, Stafford—Invention of new or improved machinery for cutting or shearing metals.

Information as to any of these applications, and their progress, may be had on application to the Editor of this Journal.

DESIGNS FOR ARTICLES OF UTILITY.

Registered from 11th April to 10th May, 1853.

- | | | |
|-------------|------|--|
| April 15th, | 3447 | G. Simons, Birmingham,—“Writing-case and taper-stand.” |
| — | 3448 | Simcox, Pemberton, & Sons, Birmingham,—“Picture suspending apparatus.” |
| — | 3449 | J. Harper, Cambridge,—“Stay-fastening.” |
| 16th, | 3450 | J. Lee & Co., Birmingham,—“Crowbar.” |
| — | 3451 | W. G. Davis, Bideford,—“Ladies' supporter.” |
| 19th, | 3452 | T. Young, Poplar,—“Emigrants' companion.” |
| — | 3453 | W. Pope and Son, Edgeware-road,—“Chimney valve-seat.” |
| 25th, | 3454 | J. Budge, St. Paneras,—“Clack-box and feed-pipe for locomotives.” |
| 29th, | 3455 | W. W. Woodhill, Birmingham,—“Door-fastener.” |
| 30th, | 3456 | J. Smith, Birmingham,—“Metallic pen.” |
| May 7th, | 3457 | Stock and Sons, Birmingham,—“Water-closet and service-box.” |
| 10th, | 3458 | D. Salomons, Great Cumberland-place,—“Railway and steam-boat signal.” |

DESIGNS FOR ARTICLES OF UTILITY.

Provisionally Registered from 16th April to 12th May, 1853.

- | | | |
|-------------|-----|--|
| April 16th, | 501 | E. Maw, Seacombe,—“Metal plate-clip.” |
| — | 502 | W. Baddeley, Islington,—“Oar.” |
| — | 503 | J. E. Boyd, Lewisham,—“Hat-cone.” |
| 27th, | 504 | D. Harcourt, Birmingham,—“Model-stand.” |
| 28th, | 505 | F. Arnold, Barnsbury,—“Bookbinding.” |
| 30th, | 506 | C. Osborne, Camberwell,—“Skein-wheel.” |
| May 9th, | 507 | J. Steuer, Birmingham,—“Dress-fastener.” |
| — | 508 | H. Bridger, Chelsea,—“Boot-scraping and brushing machine.” |
| 12th, | 509 | S. Myddleton, London,—“Gumming machine.” |
| — | 510 | C. Osborne, Camberwell,—“Expansive winder.” |

TO READERS AND CORRESPONDENTS.

A MODELLED.—A very good composition is made thus:—Pure and finely-levigated white is mixed up into a paste with glue, in the proportion of five parts of the powder to one of the glue solution. To this paste a little Venetian turpentine is added, to destroy any brittle tendency; and, to aid the working up, a little linseed oil is occasionally added to the compound, which will receive any desired colouring matter. When warmed, this substance answers well for modelling or pressing into moulds, linseed oil being necessary to prevent sticking. After cooling, it becomes quite hard.

A SUBSCRIBER will see that we have anticipated his wishes.

M. W. W. (Merthyr Tydvil.)—We have referred his inquiry to the engineer in question.

AMSTERDAM.—Special instructions are wanted.

BOOKS RECEIVED.—“Clegg on Coal Gas, 2d edition.”—“Wordsworth's Summary of the Law of Patents.”—“The Prairie Farmer, Chicago, U. S., for April and May.”

W. B.—His communication is in preparation.
J. P.—See Fincham's Works. We are not acquainted with any separate treatise on Iron Ship-building. Mr. Russell's wave-line system is described in many works. Search the pages of the back volumes of the *Practical Mechanic's Journal*.

T. T.—The formula will not apply for such excessive speeds. Separate calculations must be made for these cases. Theoretically speaking, the resulting width is enough for so high a rate. No one ever calculated the band for the spindle of a spring machine running at 5 or 6,000 revolutions, the reason being that the power actually transmitted through one foot, for instance, is almost unappreciable. We are obliged for our correspondent's attention, as it is certainly a point yet to be examined.

TAYLOR'S TRUNK AND LIFTING APPARATUS FOR THE SCREW PROPELLER.—We have received the following communication from Mr. J. O. Taylor, the inventor and patentee of the trunk or well-hole and lifting apparatus for the screw propeller:—

“In the *Imperial Cyclopaedia of Machinery*, Part VI., pages 32, 33, and 34, there is a statement calculated to do me considerable injury, if allowed to remain uncontradicted;—viz., that Mr. F. P. Smith is the inventor of the well-hole or trunk and lifting apparatus for the screw propeller; and I, therefore, shall feel obliged by your giving, in your next number, my unqualified contradiction to such an assertion. I am well known to be the only inventor and patentee of the trunk and lifting gear—an invention and patent which, after due examination by the Privy Council, their Lordships have consented to extend several years beyond the original grant.

“18 *Bucklersbury*, May 20, 1853.”

“J. J. O. TAYLOR.”

J. JONES, PATENTEE.

Fig. 1.

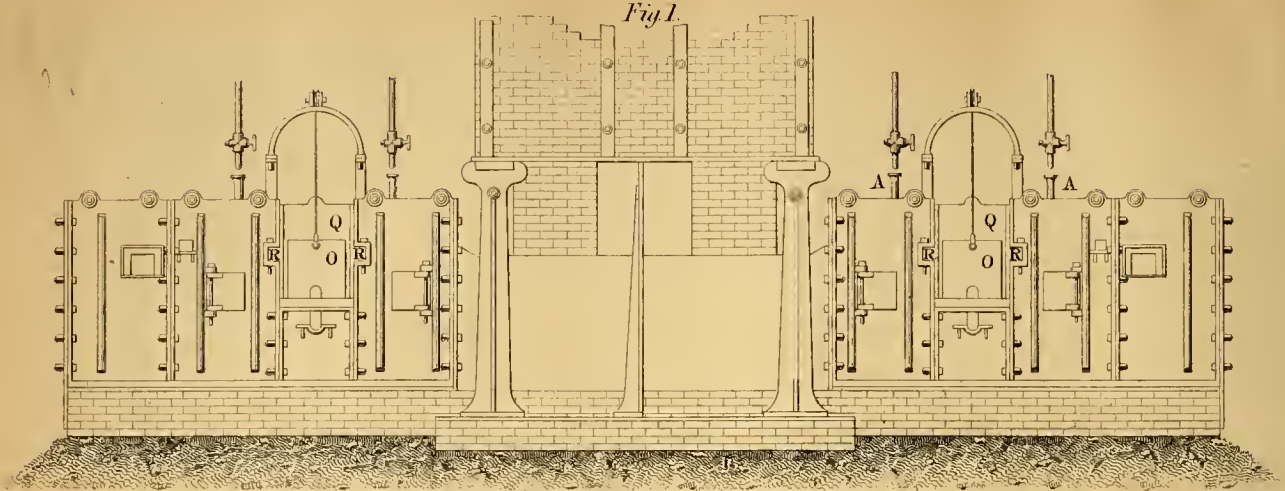

Fig. 2.

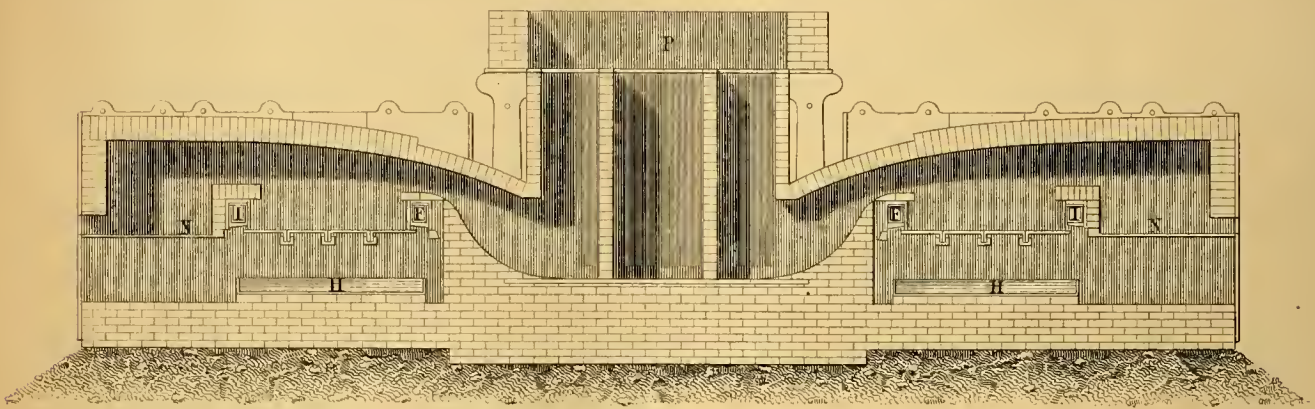
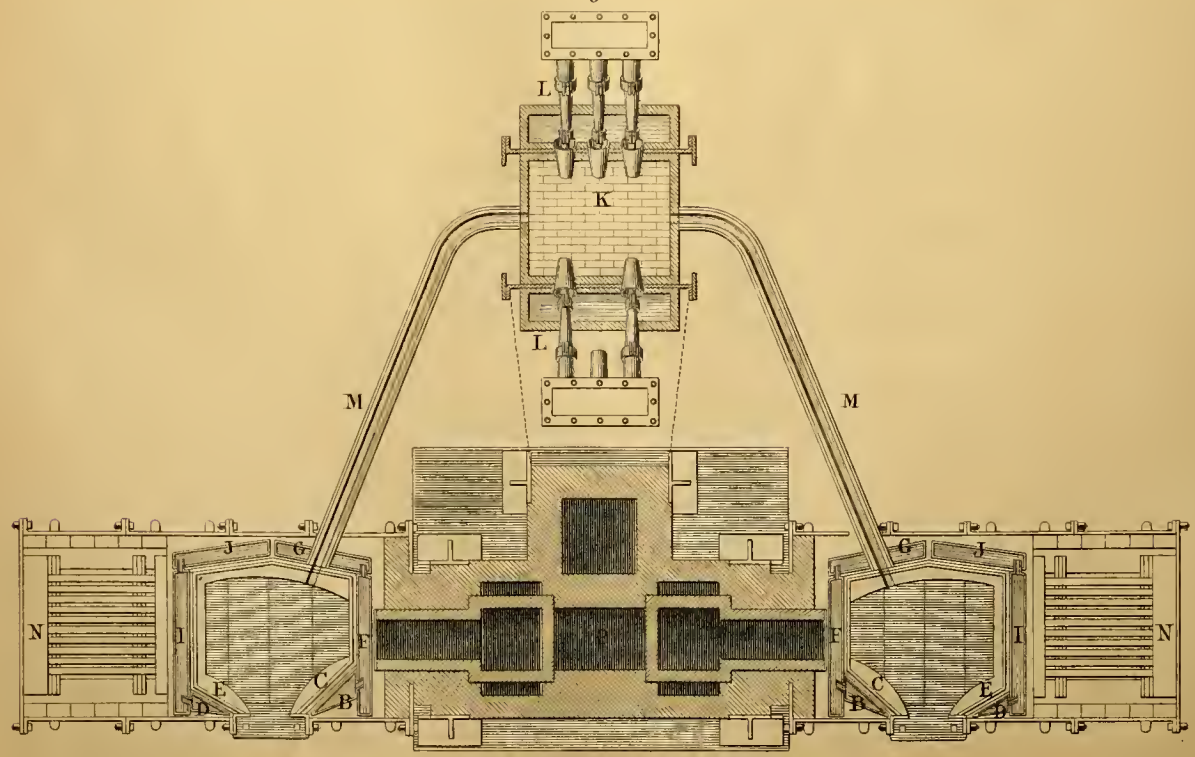

Fig. 3.



Scale

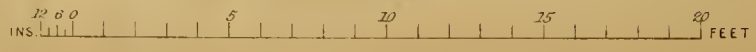

Fig. 1.

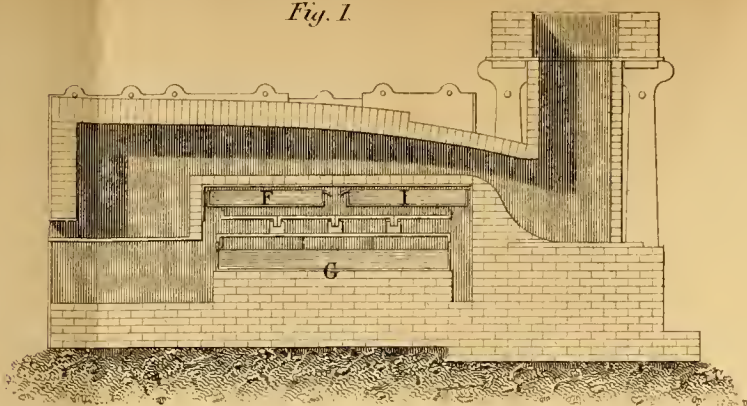

Fig. 6.

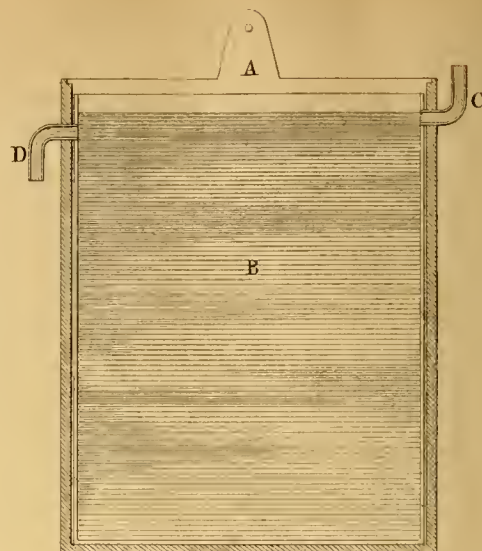

Fig. 2.

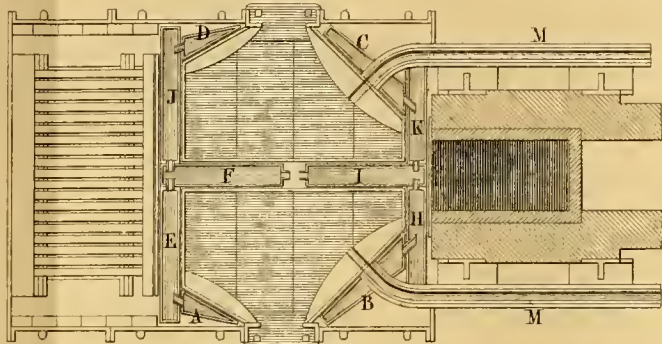

Fig. 7.



REFINING & PUDDLING FURNACES.

J. JONES, PATENTEE.

Fig. 3.

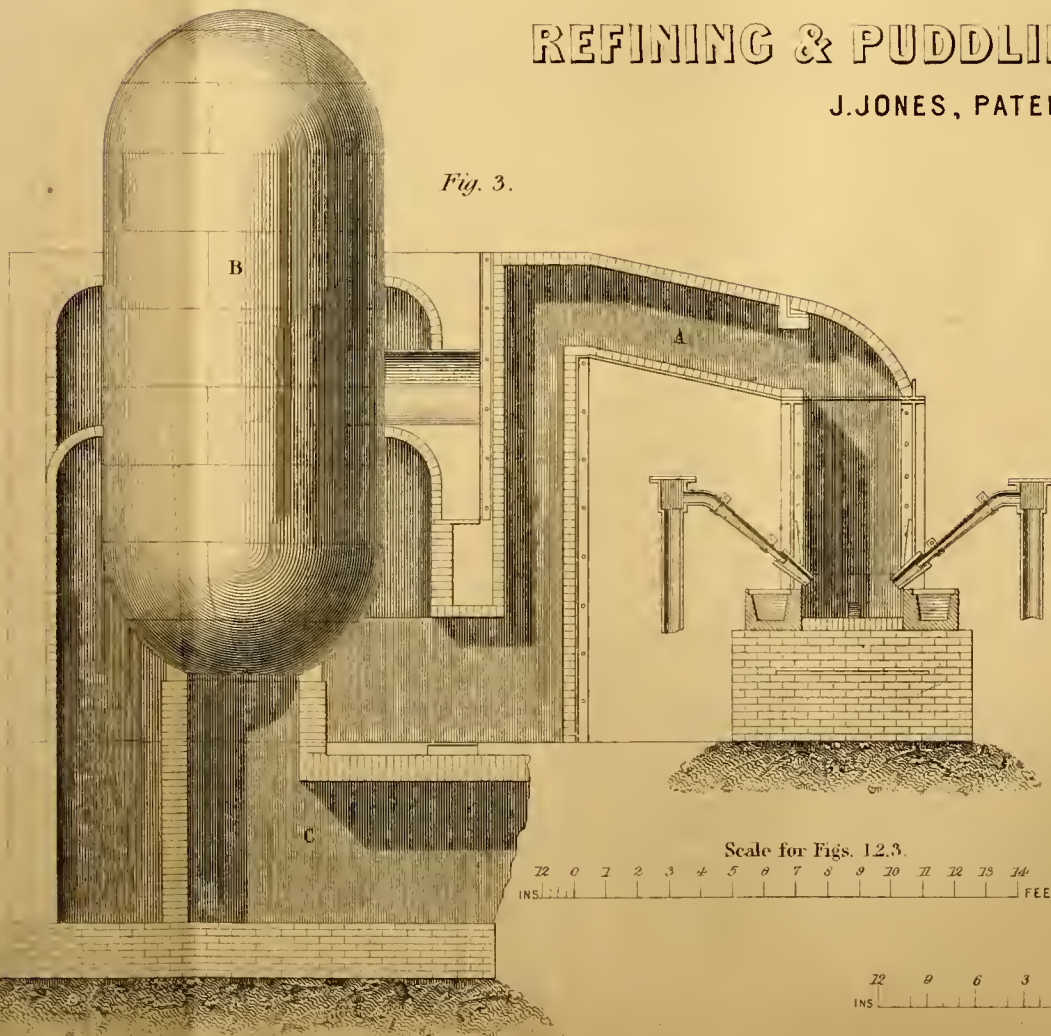

Fig. 4.

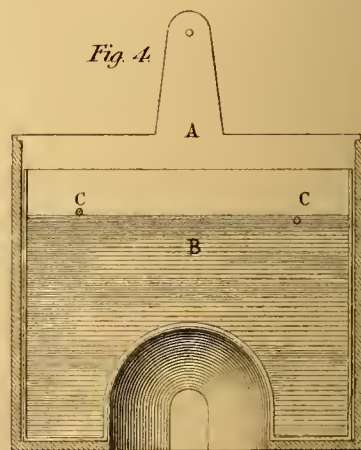
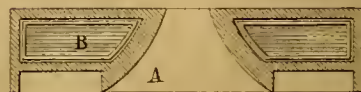
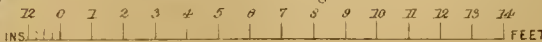

Fig. 5.



Scale for Figs. 1, 2, 3.



Scale for Figs. 4, 5, 6, 7.



JONES' IRON REFINING AND PUDDLING FURNACES.

(Illustrated by Plates 129 and 130.)

"The ores of iron are scattered over the crust of the globe with a beneficent profusion, proportioned to the utility of the metal; they are found under every latitude, and every zone; in every mineral formation, and are disseminated in every soil. Every person knows the manifold uses of this truly precious metal; it is capable of being cast in moulds of any form; of being drawn out into wires of any desired strength or fineness; of being extended into plates or sheets; of being bent in every direction; of being sharpened, hardened, and softened at pleasure. Iron accommodates itself to all our wants, our desires, and even our caprices; it is equally serviceable to the arts, the sciences, to agriculture and war; the same ore furnishes the sword, the ploughshare, the scythe, the pruning-hook, the needle, the graver, the spring of a watch, or of a carriage, the chisel, the chain, the anchor, the compass, the cannon, and the bomb. It is a medicine of much virtue, and the only metal friendly to the human frame."—Ure.

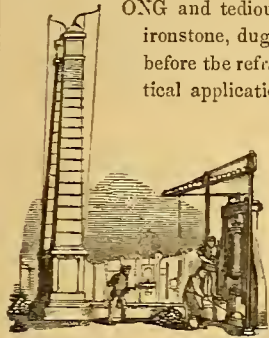

LONG and tedious are the processes through which the crude ironstone, dug from the deposit beds of nature, must pass, before the refractory mineral is fitted for the bulk of its practical applications. It must be roasted, smelted, remelted,

refined, puddled, hammered, squeezed, and rolled, before it attains the ductile condition of even a raw bar; and a further nice process of steel conversion is necessary to bring it to the condition involved in the manufacture of a vast variety of articles, from a scythe, or pair of shears, to a needle. The machinery and the general process of smelting, or the first running of the com-

paratively pure, but crude metal, from its earthy matrix, have been frequently discussed in these pages. Such information is to be found in the several papers on "Budd's Blast Furnaces," arranged for economising the escape gases (page 12, Vol. II.); "Calcination of the Ore by the Waste Gases at the Coltness Furnaces," by Mr. Houldsworth (page 4, Vol. V.); and the "Arrangement of the Materials and the Application of the Waste Gases in Blast Furnaces," by Mr. Blackwell (page 250, Vol. 5); and several other dissertations of more or less note. We now go a step further in describing and illustrating the most recent improvements in the great secondary process of "refining" and "puddling" the cast metal, for the purpose of imparting to it the important quality of malleability, so that it may be worked between laminating rollers, or under the hammer of the smith, and fashioned by pressure and impact, into a thousand shapes, just as the molten mass is primarily shaped and moulded as it flows from the furnace. To accomplish this, the broken pig metal, as it is found in the rough open moulds of the smelter, is placed in a separate small heated chamber or "refinery," where it is slowly melted in contact with coke, or charcoal, and kept for some time at an elevated temperature, for the removal of a portion of the impurities, prior to treatment in the puddling furnace. The metal so refined is then run off from this chamber and allowed to cool; and in this partially purified state, it is placed in a reverberatory furnace, where it is softened and worked up by the puddler into lumps, or heavy plastic masses, to be afterwards worked under the steam hammer, or "sbingled" and rolled out into bars or plates.

The improvements which are now before us, are those of Mr. Joseph Jones, of Bilston, Stafford, an iron maker of considerable experience. They consist—1st, of the application of a cooling current of water to a water-space chamber, or series of troughs encircling the heated mass in the puddling furnace, so that the material of which the furnace is composed, is kept cool, and comparatively uninjured during the puddling and working operation.

2d, The combination of the refinery with the puddling furnace by pipes or ducts passing between the two, so that the refined metal may flow directly from the refining chamber on to the puddling hearth, dispensing with all the ordinary labour, waste of material, and loss of time in the removal.

3d, The connecting the refinery furnace flue with a chimney or stalk,

for the purpose of carrying off the heated air and sparks from the refinery, and facilitating the operations of the workmen.

4th, The carrying a flue from the refinery furnace into the flues of a steam-boiler, so that the otherwise waste heat of the refinery may be made available for generating steam.

Fig. 1, on plate 129, is a longitudinal elevation of two of Mr. Jones' puddling furnaces combined together, and fitted up in this way, with the refinery attached. Fig. 2 is a corresponding vertical section of the same, and fig. 3 is a horizontal section or plan. Fig. 1, on plate 130, is a sectional elevation of a duplex puddling furnace, as arranged to be worked in connection with a single refinery, not shown in the figure; and fig. 2 is a horizontal section of the same, showing the refinery ducts as broken away. Fig. 3 is a sectional elevation of a refinery furnace combined with a steam-boiler, which is built into a flue communicating with the discharge flue of the furnace, the refining heat thus serving for both purposes. Figs. 4 and 5 are, respectively, vertical and horizontal sections of the water-space furnace-door; and figs. 6 and 7 are similar sections of a sliding damper of the like construction. The cooling water is conducted to the furnace shell by the vertical pipes, a, in communication with a cold water reservoir, conveniently placed for the purpose. The water enters in its cold state into the trough, or water-space, b, at the back of the flue jamb-plates, c, as well as into the water-space, d, behind the bridge jamb-plates, e. From the space, b, the fluid passes into the water-space, f, between the flue bridge plates, thence into the space, g, set near the back wall plate of the furnace, and it is finally discharged into the tank, h, under the bottom plates of the furnace. The water supplied to the space, d, passes to the space, i, between the fire bridge plates, and thence into the space, j, near the back wall plates of the furnace. After passing through this course, the heated current is finally received as before, by the bottom tank, h. By this contrivance, the whole of the parts exposed to the intense heat of the puddling process, are effectually kept cool, as the passing current surrounds every part of the containing shell, and carries off the excess heat by a constant uniform action before any evil effect can arise. The refinery into which the raw pig-iron is put, in a broken state, for melting, is at k. It is blown by tuyeres, l, on two opposite sides, in the usual way, and as the metal is melted and refined, it is run out direct into the two puddling furnaces, by the inclined side pipes, or ducts, m. In this way the metal is at once conveyed to the puddling hearths, without the slightest additional trouble. The two puddling furnaces are of the usual reverberatory kind, and their grates, n, are supplied with coals in the ordinary manner, the iron being worked through a side opening governed by a balanced sliding door, o. The flues from both furnaces pass into the central or intermediate chimney, p, carried on cast-iron framing. The entire furnace is encased in massive iron plates, stayed together across the top transversely by tension rods, and the fixed guide-piece, q, for the operating door is cast with side lugs, r, fitting into corresponding recesses cast on the main frame plates, a bolt being put through from the upper side, in each case, to bind the whole together.

The duplex-furnace, figs. 1 and 2 on Plate 130, is constructed in a similar way, the only difference being, that a furnace with a central division is placed at one end of the arrangement, and the single refinery at the other, with the chimney between. The cold water is brought down from above to the cooling cells, a, b, c, d, as before. The water from the division, a, passes along and through the division, e, and thence to the next one, f, forming a part of the central division—finally falling into the trough, g. On the other side, the water from the section, b, flows into the space, h, and thence into the central one, i, from which it finds its way into the tank, e, as before. Similarly, the water from the division, d, passes through the contiguous spaces, j and f, to the receiving tank, and that from the space, c, escapes into the same receptacle when it has traversed the two divisions, k and i. The refinery, supplies its melted metal to the puddling furnace by the two side

ducts, *m*, embracing the central brick-work. This forms a very compact arrangement.

The combination of the refinery with an elevated main stalk is not represented in the plates. It consists simply in carrying up a short flue directly from the refining hearth, this flue terminating in the bottom of an inclined flue branch, the other end of which opens into the side of the detached chimney, to give a stroug, clear discharge of the products of combustion. Fig. 3, on Plate 130, represents a refinery of similar build, with a partially inclined overhead flue, *a*, conveying the heated matters into the flues surrounding the vertical hemispherically-ended boiler, *b*. After winding well round the exterior of the lower part of the boiler, the current is directed through a central flue in the boiler, and finally off by the bottom flue, *c*, to the chimney. This affords a very convenient means of economizing the escape-heat of the refinery, without any additional details of importance.

In the details, figs. 4 and 5, *a* is the outer case of the water-space furnace door, having two vertical ducts at its upper part to convey the cold water. The space, *b*, contains the water, being furnished with two spouts, *c*, entering the slots or ducts in the outer case, and thus a stream of water may be kept running through the space, *c*, from a pipe branching from the pipes already referred to as taking the water to the furnace-spaces. Such pipe is, of course, fitted with joints, so as to allow of its being moved out of the way when the door is to be shifted, or a flexible pipe may be adapted to permit of this action. The water enters at one of the spouts, *c*, and flows off by the other, so as to present a constantly changing fluid stratum to the heated plates. The sliding damper is represented in similar views, figs. 6 and 7. Here, *a* is the external shell of the damper, and *b* is the water space in the interior. The water is introduced by the pipe, *c*, and carried away by the opposite one, *d*.

By these arrangements, a most complete preventive system is put in force to secure every exposed part of the furnace from liability to injury from the intense heat of the puddling process, and as this very desirable end is attained by means of the simplest nature, the invention is to be regarded as a most valuable expedient for economizing the cost of manufacture, and saving the time which would otherwise be wasted in effecting repairs.

These improvements have been in use at the Monkland Iron Company's Works in Scotland for the last twelve months, and the great economy and ease of working which they have introduced, has led to eager inquiries for the new plans at many other iron-works.

THE LAW OF HOLLAND AND BELGIUM AS TO PATENTS FOR INVENTIONS.

Patents for inventions in Holland and Belgium are regulated by a law promulgated in January, 1817, and by another law made in August, 1827, when both countries were united under one sovereign. They still remain in force in the two kingdoms, notwithstanding their subsequent separation. The earlier law sets out with declaring that patents are not to prejudice other parties, and that they shall be invalid when the patented invention had been previously in use in the kingdom. Patents may be obtained for five, ten, or fifteen years. The government charges are, respectively, 317 francs, 635 francs, and 1270 francs. A patent obtained for five or ten years may be prolonged, sufficient reason being shown, to the full term of fifteen years; but as such prolongations are not easily obtainable, it is better to apply for a duration of fifteen years at first.

A patent obtained for an imported invention will expire with the patent obtained in respect of the same invention in the foreign country, and the invention must be exercised in the kingdom.

It secures to the patentee the exclusive right of manufacturing and selling throughout the kingdom, or of licensing others to make and sell, objects to which the patent refers. Also, the right of proceeding in the courts of law against persons guilty of infringing the patent.

Whenever a patent is demanded, an exact detailed description must be deposited, under seal, of the object or secret for which a patent is sought, accompanied by the necessary plans and designs (in duplicate), samples or patterns. This description will not be published until after the expiration of the patent.

A petitioner, when he lodges his petition, is required to give an undertaking to accept the patent, if granted; to pay the dues within three months; and to submit, in the event of not fulfilling this undertaking, to have the patent annulled, and the invention made public.

In Belgium, when the application is in respect of an imported invention, the petition must declare whether the invention has or has not been patented in a foreign country, giving the exact date and duration of the foreign patent (if there be one), and the name of the patentee, and producing proof of the accuracy of the statements made.

A patent will be void (1.) if it appears that the petitioner has wilfully omitted to describe any part of his secret, or has given a fraudulent explanation in his specification: (2.) if it appears that the subject of the patent has been described in some printed and published work: (3.) if the patentee shall not put his invention into practice within two years of the grant, unless there are special reasons, of which the government will judge: (4.) if the patentee should, after obtaining his patent, obtain a patent in any other country: * (5.) if it appears that the patented invention is dangerous in its nature or application to the security of the kingdom or its inhabitants. Should a patent be pronounced null on any of these grounds, so much of the tax as is proportionate to the time which it may have to run will be returned.

Persons applying for patents must deliver, at the Secrétariat of the provincial government, a petition to the king, containing a general statement of his demand, his name and domicile, and the term for which he seeks a patent. This will be forwarded to the minister of the interior within ten days from the date of the deposit. The petition is then presented to the king, with the commissary-general's report. If doubt is felt as to the propriety of granting a patent, the king may take the opinion of the Royal Institution of the Netherlands, or of the Royal Academy of Sciences at Brussels. The patent contains a description of the invention; it indicates the rights granted to patentees, and expressly announces that the government in no wise guarantees the priority or the merit of the invention. When the patent is in respect of an invention already patented in a foreign country, it shall also state that the government does not guarantee the truth of the petitioner's assertion as to the duration of the foreign patent; and shall direct that the objects protected by the patent shall be made in the country.

Where a patentee has invented an improvement, he may obtain a patent of addition for the term for which the original patent has to run, or he may apply for a new patent in the same manner as if he were applying for an independent invention.

Another person may obtain a patent for improvements on an invention already patented, but in such a case the second patentee shall have no right to use the invention of the first patentee without his permission, nor shall the first patentee make use of the patented improvement without the second patentee's license. But mere alterations in form or proportion, nor ornaments, cannot be patented as improvements.

In Belgium, the description lodged on applying for a patent for an improvement or addition, must distinctly indicate in what the improvement consists, and in what the addition differs from the original invention.

Government makes no charge on patents of addition, where the improvement strictly relates to the patent previously taken; but all sums due in respect of the former patent, must be paid before application is made for a patent of addition.

Before a patentee can transfer his patent, either wholly or in part, he must obtain the royal license, and the instrument of transfer must be registered at the Secrétariat of the provincial government. The tax on a transfer is about 18 francs. Persons succeeding by inheritance to the rights of a patentee must likewise register their title.

On the expiration or nullification of a patent, the commissary-general of instruction shall publish the patented invention, unless there are reasons of a political or commercial nature which induce him to refrain from publishing it; in which case he reports to the king, who decides as to the publication.

The law directs that the commissary-general shall send the patent, when signed by the king, to the governor of the province where the patentee is domiciled, and that the patentee shall be entitled to receive the instrument on producing a receipt for the tax. But of late years the patentee is required to pay only about ten per cent. of the tax in the first instance, and he gives an undertaking to pay the remainder within two years.

A register of patents and assignments is kept by the commissary-general, which is open to the inspection of all persons desirous of applying for patents.

* This absurd regulation is got rid of in practice by the patentee taking the foreign patents in another name, and then having them transferred to him.

OUTLINES OF GEOLOGY.

VII.

TERTIARY EPOCH.

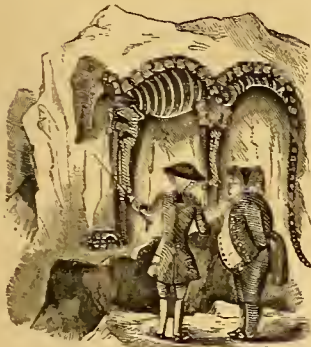

ORE and more, as geological history approaches to the present times, do the records increase in number, whilst they are written in a language less foreign to us. The story they tell is both strange and perplexing.

At the close of the secondary epoch, the internal skeleton of the earth's crust had been nearly completed, though some of its features were still wanting, for the principal mountain-chains of Europe existed not in their present form. The Alps, Pyrenees, Carpathians, and Apennines, were all elevated to their present height during the tertiary

epoch, though they may have existed as lower ranges in an antecedent epoch. The Mediterranean knew not its present bounds, but, continuous with the North Sea, the Indian Ocean, and the Atlantic, circulated freely among the islands of which Europe and a part of Asia then consisted. The great desert of Africa lay beneath its waters. India was a triangular island, cut off from the Himalayas by a wide channel. An inland sea occupied Central Asia, Asia itself being separated from the Scandinavian continent (of Sweden, Norway, and part of Russia) by a broad arm of the Northern Ocean.

In the New World, South America was the most below its present growth. The great Andean chain, however, occupied the same range which it does at present, though its height was probably less. What is now Brazil appeared as a large island, to the north of which land had begun to rise from the sea; but the Atlantic and Pacific Oceans communicated with each other by an open channel, where the isthmus of Panama now is.

Looking only at the British islands, the physical changes of the tertiary epoch were not great. The newest rocks in our island consist of the London and Hampshire basins, and of low lands, near the coast. It is certain, however, that considerable changes of level must have occurred in some places, with little or no addition to the dry land: for instance, in North Wales, where recent shells are found at a height in one place (Moel Trefaen) of 1630 feet above the sea. The whole western coast of Britain appears to have undergone a gradual elevation during the tertiary epoch. This elevating movement may be traced from the Shetland isles, where it amounts to about 250 feet, to the south coast of England, the maximum of elevation being that in North Wales, from which, proceeding southwards, it gradually declines to about 60 feet. On the eastern coast of the island there is evidence of slight depression having occurred in recent times. The following table shows the rocks of the tertiary epoch as they occur in Britain:—

BRITISH.	FOREIGN.
Recent Deposits— Comprising raised beaches, peat bogs, submerged forests, deposits in caverns, shell marks.	Similar appearances in Northern Europe, Siberia, and America.
Pleistocene, or Drift Period— 1. Upper gravel and sand. 2. Till. 3. Mammaliferous crag. 4. Fresh water, sand, and gravel.	Similar, or equivalent beds, occur in various parts of Northern Europe and America; also in Sicily, and over large tracts in South America.
Pliocene— Red crag.	Loess of the Rhine. Subappennine beds. Brown coal (of Germany). Belgian tertiaries (crag). Sivalik beds of Northern India, supposed to be contemporaneous.
Miocene— Coralline crag.	Touraine and Bordeaux beds. Upper part of Molasse of Switzerland. Vienna basin. Equivalent beds in Europe, Asia, North Africa, and North America.
Eocene— 1. Fluvio-marine beds. 2. Barton clays. 3. Bagshot and Bracklesham sands. 4. London clay and Bognor beds. 5. Plastic and mottled clays, sands, and shingles.	Paris basin. Central France. Molasse of Switzerland (lower beds). Belgian tertiaries. Various beds in Western Asia and India, and in North and South America. Nummulitic beds.

The lowest, or eocene, tertiary is well distinguished from the rest of

the series, which is not the case with the upper divisions. Moreover, it is the only part which is much developed in England.

By the following arrangement, the equivalent beds of the London, Hampshire, and Paris basins are shown:—

LONDON.	HAMPSHIRE.	PARIS.
		Av. thick. in ft.
		Millstones and clays,..... 80
		Upper freshwater marls and limestones,..... } 150
		Gypseous series,..... } 150
		Lower freshwater marls and limestones,..... } 150
	Av. thick. in ft.	Grès de Beauchamp,..... 50
	Fluvio-marine and fresh-water series,..... 350	Calcaire grossier, and glauconie grossière,..... 100
Av. thick. in ft.	Barton clays,..... 300	Sables inférieurs (part.),... 100
Bagshot sand,..... 400	Bracklesham sands,..... 700	Argile plastique,..... 60
London clay,..... 350	Bognor beds,..... 250	
Mottled clay and sand, 80	Mottled clay and sand, .. 150	
830	1750	540

One of the peculiarities of these tertiary strata, is the alternation of freshwater and marine beds. In this peculiarity the English and French beds agree. Moreover, the lowest beds in each agree in mineral composition. The most interesting part of the Paris beds—the gypseous strata—are absent from the British series. They consist of beds of siliceous limestone and white and green marls and gypsum, which appear to be chiefly of freshwater origin, and are full of organic remains. The lower part of the gypsum beds abounds in the remains of extinct quadrupeds.

Looking beyond the basins of Northern Europe, there are numerous beds belonging to the early part of the same epoch, which are very interesting. An extensive formation, distinguished by containing an abundance of the genus Nummulites—shells supposed to have belonged to the order of foraminiferous Cephalopoda; they resemble coins, and vary in size, from that of a crown-piece to microscopic smallness—has been shown by Sir R. Murchison to belong in part to the eocene tertiary period, though formerly placed in the cretaceous system. It has been traced through a great part of Europe and Asia, its northernmost ridge on the north flank of the Carpathians being identifiable with its southernmost known limb in Cutch, and its western masses in Spain and Morocco being similar to those of the Bramahpootra. In the Swiss Alps, it occurs at an elevation of 10,000 feet. The middle tertiary series is little seen in Britain. It consists of calcareous sands, limestones, and marls, which occur in thin beds on the coast of Suffolk and Norfolk. The part of these deposits, known as coralline crag, occupies an area of about twenty miles in length, and three or four miles in breadth, between the rivers Alde and Stour.

The newer tertiary period is principally represented in England by the red crag of Norfolk, Suffolk, and Essex. It consists of a thin bed of ferruginous gravel, abounding in fossil remains. More recent than this bed appear deposits which are assigned to what is called the drift period—the pleistocene tertiary period of some authors. This is a very remarkable, but as yet imperfectly understood, period in the earth's history. The following arrangement of the British beds of this period has been made by Prof. E. Forbes:—

1. *Glacial beds*.—Sands, gravels, and clay marls, often stratified.
2. *Till*.—Unstratified clays and gravels with boulders, common in the valley of the Clyde, and many other parts of the British islands.
3. *Mammaliferous or Norwich crag*.—Fossiliferous sands, shingles, and loam, partly of freshwater origin.
4. *Freshwater beds*.—Sands, marls, and gravels.

The most remarkable circumstance connected with these beds is, the indication they afford of a great change of temperature between the time of their accumulation and that of the deposit of the lower tertiary. The fauna and flora of the eocene tertiary is, in its general character, tropical, while the drift period requires for its explanation the supposition of icebergs floating over parts of what is now the dry land of Britain.

The number of localities in England alone where drift beds occur is very numerous. These consist generally of worn fragments of hard rock, varying in size from many cubic yards to the smallest pebble. Towards the base, these fragments are less rounded than those of the higher beds, and they are associated with clay. The rocks on which the larger fragments—boulders or erratic blocks—repose, bear marks of having been scored, scratched, or sometimes polished, by the attrition of the masses which have passed over them, the lines being traceable sometimes over large tracts. The appearance thus presented recalls the striations made by the motion of glaciers down some of the valleys of Switzerland. In some cases, the drifted matter appears to have been derived from the rocks in the immediate neighbourhood. Thus, the gravel of the neighbourhood of London consists principally of flints from the chalk.

But in the middle and northern parts of England, the masses of rock

consist principally of granite or other crystalline rock, which must have come from a distance, and can frequently be traced to particular parts of the Cumberland mountains. Blocks, many of them of great magnitude, can be traced from these mountains in three directions. They proceed northward by the vale of Eden to Carlisle. They also proceed southward between the western side of the Pennine chain and the sea to the valley of the Trent, whence they continue to the plains of Cheshire and Staffordshire, and are found even in large masses in the vale of the Severn. "The large quantity of detritus from the Cumbrian mountains," says Mr. Phillips, "which has been drifted to the south on the western side of the high mountain border of Yorkshire and Derbyshire, has gone across the drainage of the Lunc, Wyre, Ribbles, Mersey, and Weaver, into and beyond the drainage of the Trent, the Dee, and the Severn. Not, in any instance, have they overstepped to the east the mountain barrier [of the Pennine chain]; but they lie up against it in enormous quantity, and in the most inextricable confusion, not to be explained by anything like the action of the sea on its coasts, even during the most violent storms." But these erratic blocks have even crossed the Pennine chain. The passage of this chain appears to have been made at Stainmoor, where the height of the chain (14,000 feet above the sea) is comparatively low. Granite from three localities appears to have passed over this point, namely, from an elevation on Shap Fells, about 1,500 feet high, from Carrock Fell, 2,200 feet, and from Kirby Stephen, which is only 500 feet above the sea. Having crossed the Pennine ridge, the blocks proceed through Yorkshire over the Hambleton hills, to the foot of the chalk hills and the Humber; in some places, granite from Shap Fells is even found on the moors near Scarborough, Flamborough, and places beyond the chalk range. Detritus from the Cumbrian district may also be traced along the Tyne to near its mouth.

These curious facts, regarding the drift deposits of England, by no means stand alone. A great part of Northern Europe and North America is strewed with blocks so similar in character, as to imply a similar history. The European district extends from the western islands of Scotland to the flanks of the Ural mountains, and from the mountains of Scandinavia to Central Germany and Poland. In America, boulders have been traced to a distance of 1,500 miles from the parent rock, from which they are now separated by plains, valleys, and mountains. The case of boulders on the flanks of the Jura is a striking case of the phenomenon under notice. It appears, by comparing these boulders with the rocks of the Swiss Alps, that they have been conveyed from various parts of the chain quite across the plain of Switzerland, and dropped, as it were, on the flanks of the Jura—those which proceeded from the most northern part of the Alpine range, resting on the most northern part of the Jura mountains; and so in regular order. By some authors it has been conjectured, that glaciers, such as now exist in some of the upper valleys of Switzerland, formerly stretched as far as the Jura chain; but the theory which has obtained most adherents is, that the boulders in question were masses floated off in icebergs from the parent rock, and dropped when the icebergs had stranded. The same explanation is applied now to all cases of erratic rocks. Beds of drift, consisting of sands, clays, and gravel, occur in Scotland and Ireland, sometimes having a thickness of 300 feet. These deposits frequently occur at an elevation of some hundred feet above the level of the sea. It remains to notice deposits later than the drift. These, even in the British isles, are very heterogeneous, and can with difficulty be distinguished from the vegetable soil which lies above, and the underlying beds of the older period. They consist of raised benches, peat bogs, and accumulations at the mouths of rivers. In the valley of the Rhine, in Russia, in North and South America, and in other parts of the world, deposits, probably of the recent period, are abundant, and sometimes occupy extensive areas.

ORGANIC REMAINS OF THE TERTIARY EPOCH.

Of the conclusions arrived at by an examination of the fossil remains of the tertiary epoch, the most remarkable is that of a change from a tropical to an arctic climate, having occurred between the eocene and later periods. We shall mention some of the facts which lead to this inference. Sixteen species (extinct) of Mammalia have been found fossil in British eocene strata, (see Johnston's Physical Atlas.) These belong to twelve genera, nearly all extinct—a macacus (monkey), a didelphis marsupial animal, a large serpent, and numerous species of tusks, occur among these fossils. The remains of Mammalia belong chiefly to the order Pachydermata, the representatives of which are now only found in much warmer regions of the world. In the lowest beds of the Paris basin, the evidence in favour of a warm temperature is even stronger than in England. With members of the orders, Pachydermata, Carnivora, Marsupialia, and Rodentia, occur remains of tortoises, and crocodiles, and gigantic serpents. Among the remains of fish, there occur many members of existing genera; but three extinct genera appear belonging to a family now almost confined to the southern seas, one genus of a family

only found recently between the tropics, and five genera of a family which is almost confined to the Mediterranean. The same inference is suggested by the forms of molluscous animals.

In regard to the flora of this period, "the researches of Mr. Bowerbank in the London clay," says Professor E. Forbes, (Johnston's Physical Atlas,) "have made known a vast number of vegetable remains, and have given us as complete an idea of the vegetation of our era, during the eocene period, as we have of its carboniferous flora. Our eocene flora appears to have been comparable with that now existing in tropical regions of the East. Remains of palms, leguminous plants, and cypress-like coniferæ, especially characterise it." The following catalogue of all the British eocene fossils yet known is—according to a recent catalogue—

Mammalia,	14	Crustacea,	4
Birds,	1	Cirrhopoda,	3
Reptiles,	14	Annelida,	11
Fishes,	97	Foraminifera,	8
Gasteropoda and Cephalopoda,	267	Echinodermata,	5
Conchifera and Brachiopoda,	235	Zoophytes,	4
		Plants,	100

It appears, then, that the high temperature which existed in England during the carboniferous epoch, continued to as late a period as the commencement of the tertiary epoch. Now, the organic remains of the miocene and pliocene periods are of a mixed character, indicating an approximation to that cold temperature, which must have prevailed in the more recent pleistocene epoch. Thus, of the 340 species of Mollusca which occur in the coralline crag of the miocene period, 73 are recent British species. "The general character of the fauna of this epoch," says Professor E. Forbes, (Physical Atlas) "is Lusitanian. Zoophytes abound, including many southern genera." In the pliocene beds of Britain, 260 species of Testacea have been discovered, of which 60 are recent British species. Between the eocene and the pleistocene periods, appear to have lived many peculiar quadrupeds, and some of gigantic size. Such was the dinotherium, the largest terrestrial mammal of which any record has remained. The remains of this animal occur most abundantly at Epplesheim, in Hesse Darmstadt, but are found in other parts of Europe. This animal must have resembled the tapir, but in size it greatly exceeded it. It possessed two enormous tusks in the lower jaw, curved downwards, like those in the upper jaw of the walrus.

The remarkable deposits, forming part of the Sewalik hills, between the Himalayas and the upper part of the Ganges, belong to this period. Remarkably perfect and abundant fossils of Pachydermata, Carnivora, Ruminantia, and Quadrumana, and remains of crocodiles and tortoises, different from those now inhabiting those regions, have been discovered, along with others, identical with species now existing in the country. Finally, we appear to reach a maximum of cold. The fossils found in the British marine pleistocene are chiefly remains of Mollusca. They are all either living British species, now chiefly found within the Celtic region; or such as, though still living within our seas, are only abundant in the boreal region; or such as are extinct in our seas, but still survive in the arctic regions, or on the coasts of boreal America. A few southern forms, which do not now range to our seas, accompany them. The fauna of the glacial beds, including the mammaliferous crag, consists of above 170 species of marine animals, chiefly Mollusca." The quadrupeds of this period appear to have been numerous. Many of them belong to the order Pachydermata, which is contrary to what might have been expected. The bones of these animals occur plentifully in the drift gravel of England, Scotland, and Ireland. They have also been found in caverns, which, most probably, were the haunts of some of their number when alive. One of the most remarkable discoveries of this kind was in Kirkdale Cave, Yorkshire. The following bones have been enumerated:—

- Carnivora*.—Hyæna, felis, bear, wolf, fox, weasel.
- Pachydermata*.—Elephant, rhinoceros, hippopotamus, horse.
- Ruminantia*.—Ox; three species of cervus.
- Rodentia*.—Hare, rabbit, water-rat, mouse.
- Birds*.—Raven, pigeon, lark, duck, snipe.

Hyænas' teeth and bones were found in great abundance, and their excrement also occurred. Some of the bones, too, bore the marks of hyænas' teeth—so that the cave is concluded to have been a den of hyænas.

The following is the table of species of British fossil Mammalia of the pleistocene and recent periods together, according to Professor Owen. (See Physical Atlas:—)

Chiroptera,	2	Pachydermata,	8
Insectivora,	3	Ruminantia,	11
Carnivora,	12	Cetacea,	5
Rodentia,	10		

One of the most remarkable animals of the latter part of the tertiary epoch was the *elephas primigenius*, or mammoth, remains of which are found in Europe (England and elsewhere), Asia, and America, but especially in Siberia, where it has been found entombed in ice, so as to preserve its fleshy parts almost entire. The occurrence of remains of elephants in so great abundance in high latitudes, while at present they are nearly confined to the tropics, is a curious discovery, and is not yet thoroughly explained. The mastodon, also, of an elephantine type, occurs in northern Europe, among the remains of this period, although it is more frequently found in North America. As a general rule, the same differences occur between the fossil tertiary remains of the two continents of America and Europe, which exist between their living representatives. Thus, to the mammoth elephant of Europe and northern Asia, corresponds the *megatherium* in America. Of this animal, which exceeded in bulk the largest rhinoceros, Dr. Buckland says—"With the head and shoulders of a sloth, it combined in its legs and feet an admixture of the characters of the ant-eater, the armadillo, and the chlamyphorus." It probably was coated with armour, like the armadillo.

In regard to the flora of the tertiary period, the tropical character of the eocene vegetation has already been adverted to. "We have few data," says Professor E. Forbes (*Physical Atlas*), "to judge of the British miocene flora; but we have every reason to believe, that during the pliocene epoch it resembled that now found in the south of Europe, and that during the pleistocene it was composed of arctic and antarctic species, such as now live in the most northern districts of Europe, and a few of which still remain with us, surviving on the summits of the Scottish and Welsh mountains, which once were islands in the ice-bound pleistocene ocean." On the whole, therefore, the fossil fauna and flora of the latest tertiary support the view, entertained on other grounds,

that Great Britain was for a time, shortly preceding the historic period, surrounded or covered by an arctic sea, although the prevalence, about that time, of forms of quadrupeds, now restricted to warm parts of the earth, remains for more complete explanation.

As we advance from the glacial period of our country, and approach the confines of history, a peculiar interest is given to geological research, by the expectation of discovering human remains among the fossil bodies; and such hopes have not been entirely disappointed, though the precise period to which the human remains yet discovered belong is not clearly made out. They occur in northern Europe in bone caverns, along with the remains of animals now extinct. In Brazil, the remains of a race of human beings, unlike the present tribe, have been discovered; and in the island of Guadaloupe, a human skeleton has been found in some recent limestone rock. As to the bone forming part of a human pelvis, which was found associated with the remains of extinct quadrupeds in the mammoth ravine, near Natchez, Lyell could not meet with any evidence as to its position in the cliff. He believes it was picked up in the bed of the stream, which would simply imply, that it had been washed out of the cliffs. If found *in situ* at the base of the precipice, its age would probably exceed 100,000 years. It may, however, have been dislodged from some old Indian grave, near the top—in which case, it may only have been 5, 10, or 20 centuries old.

Professor Sedgwick forcibly depicts the obscurity of the period of the earth's history, immediately preceding the historical era, by saying, that at this place "a leaf has been torn out from nature's record." That the lost leaves will be partly recovered, when changes in the earth's crust shall bring to the surface records now buried beneath the ocean, can hardly be doubted. Whatever gaps may then remain, will probably not appear greater, when seen from a distance, than those which separate anterior epochs in the geological history of the globe.

LORD BERRIEDALE'S CONTINUOUS ACTION-LOOM FOR NARROW FABRICS.

Fig. 1.

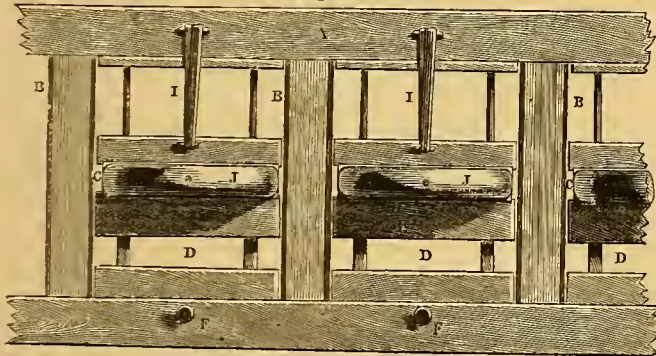
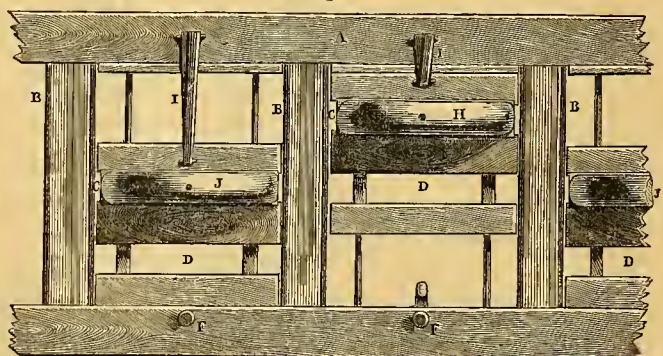

Fig. 2.



This loom, invented and patented by Lord Berrisdale, is intended for manufacturing narrow goods of all kinds, such as tapes, ribbons, and other goods, where each loom contains an extended series of shuttles or weft-conductors, working in a continuous line, and all, or most of them, in action at once, upon its separate line of fabric. In weaving such fabrics in the ordinary manner, the whole set of shuttles must always be stopped whenever the weft thread of any single one breaks, or whenever it is necessary, from any cause, that one or more shuttles should be stopped or removed. Now, in Lord Berrisdale's loom, the shuttles are so arranged, that any one of them may be stopped and taken out, without disturbing the rest, or stopping the loom. This is accomplished by adapting a species of detached duplex race for each individual shuttle, one above the other, the upper one only being actually used for the traverse of that particular shuttle therein, whilst the lower one is contrived for the periodical entry therein of the next shuttle on each side of the particular one which is stopped. So long as the whole of the shuttles are in regular work with unbroken threads, the series works just as in the ordinary way; that is, the whole line traverses a certain distance across the line of goods—the first shuttle filling up the place left by the second, and the second that of the third, and so on throughout the series. But when any given shuttle is to be stopped and removed, the particular race or guide of that shuttle is made to ascend by a spring detent action, so that the intended shuttle shall be carried up out of the line; whilst the same movement obviously carries up the lower or duplicate race into the line of shuttles to afford a place for the reception of the contiguous shuttle on each side of the one removed, as they alternately come across from each side. The whole of the other shuttles still continue to weave, whilst the elevated or disarranged shuttle may be removed by the attendant, and reinserted in its race when again ready for work. When so

inserted, the duplex race is made to descend, and the removed shuttle is thus brought back to its line of action. It is obvious that the weaver must watch an opportunity both at the removal and return of the shuttle, so that the loom's action may not be interfered with in any way.

The annexed engravings illustrate the shuttle action under different circumstances. Fig. 1 is a front view of a portion of a loom lathe, as broken away at each end, showing the duplex races down, as they are whilst all is going right in the weaving. Fig. 2 is a similar detail, with one of the races carried up for the removal of a shuttle. A is the lathe, carrying the series of narrow reeds, b, one for each line of the fabric; and at c d are the intermediate duplex shuttle races, capable of a short vertical movement on guide spindles on the lathe behind. Each race is suspended from the upper bar of the lathe by an elastic band, e, whilst at the bottom side it has a spring detent, f, to catch and hold it down when made to descend to the position shown in fig. 1. The shuttles are at g, working along the upper line of the duplex races, the whole set being thrown at once, so that each gives way to its neighbour, as they all simultaneously pass from one race into the next. When a weft thread breaks, the weaver presses forward a small spring-stop in the loom frame, and at the next forward stroke of the lathe, this stop strikes the detent, f, and liberates that particular race. The spring, e, now at once carries up the duplex race to the position of the one marked u, in fig. 2, the defective shuttle is thus carried clear of the working line, and may be slipped out at the end of its race for renewal; whilst, at the same time, the lower line of the race, n, takes the place just left by the upper one, and affords room for the other shuttles as before. This invention is now in active operation on a great many looms in the works of Messrs. James Chadwick and Brother, Eagley, and Messrs. I. & N. Phillips & Co., Tean Hall.

The increase of production by this loom is full $7\frac{1}{2}$ per cent.

GILLESPIE'S INCLINOMETER OR LEVEL.

The "Inclinometer" is a simple contrivance, originally devised by W. Gillespie, Esq. of Torbanehill, Linlithgowshire, for the purpose of facilitating the formation of a drain to carry off the water from the foundations of his house. The circumstances of the case demanded especial exactness and uniformity of slope, and the quantity of water to be removed was very considerable; for on going down $2\frac{1}{2}$ feet, it was found that the house was actually standing on a hydrostatic bed. This accumulation of moisture was to be discharged by a drain, sunk direct $5\frac{1}{2}$ feet at the very door-step. Commencing at such a depth, it was, of course, essential to guide the slope with accuracy, so as to preserve the outfall at the other extremity; and it was evident that any misdirection might endanger the house by causing the unpleasant result of back-water. During the progress of the work, Mr. Gillespie being dissatisfied with its appearance, conceived the idea of the apparatus which we now engrave, and the working model of impromptu construction, at once set the matter right. The instrument, which is made by Messrs. Young, Peddie, & Co., of Edinburgh, and is now in established use, is nothing more than a parallelogram of timber and a plummet, in combination. Our sketch shows it as pointing out the slope of a line of drain pipes. From the nature of the parallelogram, A, B, C, D, it is obvious that the top, A, D, must be parallel with the base, B, C; and to show the deviation of the upper of these coinciding slopes from the level, the instrument is

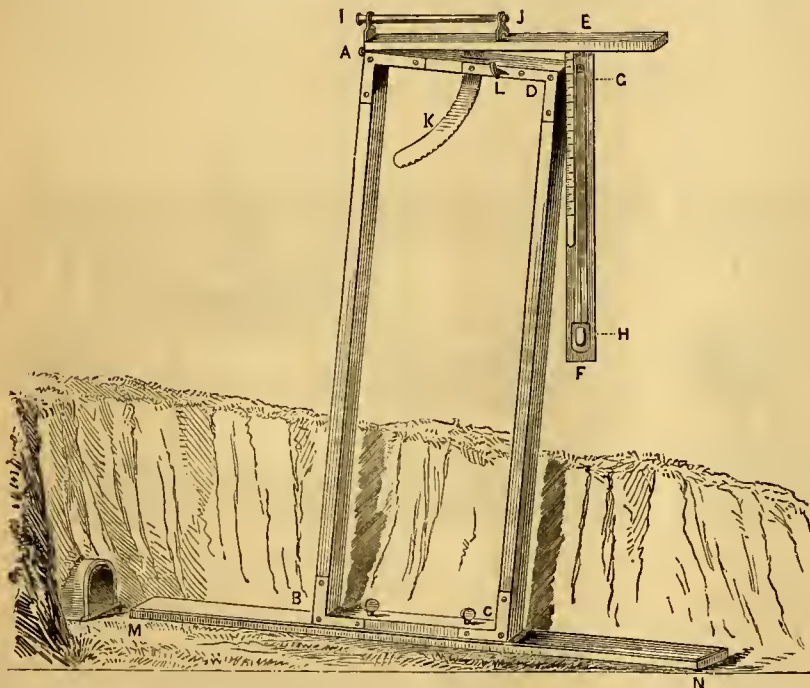

provided with the means of determining what the true level is. It has a duplicate top, A E, hinged to the angle, A. The other extremity of this duplicate top being a little protracted, is formed into the well-known T square by insertion through a slit (in which a slight range is given to accommodate the working of the implement) of a depending limb, E F, at right angles to A E. E F is graduated downwards for several inches in sixteenths of an inch. The face of the depending limb is likewise grooved for the reception of a plummet, G H, or pendulum of wire playing upon its graduated front. A quadrant, K, moved by turning the ratchet-pin, L, is employed to elevate or depress the duplicate top spar, A E, until the plummet rests from its oscillations, in exact accordance with a vertical line drawn down the face of the T square. This shows the top spar, A E, to have been adjusted to the proper level. On the other side of the implement, behind the ratchet pin, will be found an inverted pinch or pressing screw, by turning which backwards, the implement is set, and the square top fixed on the horizontal or true level.

The limb, A E, being now upon the level, whilst the limb, A D, still continues to indicate the slope, the difference intervening betwixt the level and the slope is necessarily denoted on the graduated scale, which being fixed upon the inner edge of the plummet style, measures the exact rate of slope to which the instrument is applied. I J is a slight telescope for extending the range of the level. By means of it, the out-

fall or depth of slope can be determined throughout any distance within the scope of vision, and the heights of objects may be measured where their distances can be ascertained. M N is an extra base bar, protracting the slope, and giving the rate of it with greater certainty of precision.

The practical drainer, or road-maker, will require no further explanation from us, to see how intimately this contrivance bears upon their respective employments.

FEARN'S IMPROVEMENTS IN ORNAMENTS METALLIC SURFACES.

(Illustrated by Plate 131.)

Under the title of "Improvements in Ornamenting Metallic Surfaces, and in the Machinery and Apparatus to be employed therein," Mr. Thomas Fearn, the electro-metallurgist of Birmingham, has recently patented a series of valuable arrangements for producing pressed, engraved, or embossed designs on metallic surfaces, such as tubes, rods, or strips, and other details by mechanical means. The peculiar apparatus which he employs is fully delineated in our Plate 131, where fig. 1 is a plan of the machine; fig. 2, a side elevation corresponding; fig. 3, a horizontal section; fig. 4, a vertical section; fig. 5, a plan of the underside of the drum or box; fig. 6, a section of the same part; fig. 7, a plan of the plate carrying the hearings for the rollers; fig. 8, an elevation corresponding; figs. 9 and 10, views of the rollers and their hearing blocks as arranged to produce spiral devices; and fig. 11, the same when intended for patterns running in a direct line.

The outer casing of this machine, which is intended to apply to metal tubes and rods, consists of a cylindrical box or drum, as delineated in figs. 1 and 2, having an aperture, F, through the centre. Inside this box, is fixed, by means of screw pins passing through the whole, a plate of brass of the form shown at figs. 7 and 8, and at B, figs. 3 and 4. The thickness of this latter plate is equal to the inside depth of the casing, and it also has an aperture through the centre, corresponding exactly with that in the outer casing; and on its upper side, any desired number of grooves, C, figs. 7 and 8, are cut to a depth of about two-thirds of its thickness, and radiating from the centre to the circumference. Into these grooves are fitted the short steel bars, or hearing blocks, shown in fig. 11, in which are hung small wheels, H, secured by, and revolving upon, pins bearing in the sides of the blocks. On the peripheries of these wheels, suitable patterns are either cut in relief or engraved, according to the design required to be produced on the tube or rod. These bars, or hearing blocks, with the wheels hung within, are then laid in the grooves, C, fig. 7, the wheels towards the centre of the machine, and the cover of the outer casing screwed on by the screw pins, A, fig. 1. If a tube is to be operated on, a rod of steel tapered at one end, is inserted into the tube, and acts as a mandrel. One end of the tube is then also slightly tapered, and placed in the aperture in the centre of the machine, F, fig. 1, where it is received between the converging rollers, which are then driven home to the tube by means of the screws, D, passing through the rim of the box, and bearing in the opposite ends of the blocks carrying the rollers. By these screws the pressure is regulated, and, consequently, the depth of the impression required in the tube is modulated. The pins, E, are now screwed down on the bars to keep them steady.

The machine is afterwards taken to a common draw-bench, and the tube is drawn through. This action causes the rollers to rotate, impressing on the surface of the tube the design that may be cut or engraved on their peripheries. The tube, on leaving this machine, presents a wrinkled appearance, and to remove this, it is passed through an ordinary draw-plate, which smoothes the surface, and at the same time sharpens the impression. When it is required to produce a pattern running spirally round the tube, the patentee slits the bars of steel which bear the engraving rollers, at such an angle, that the wheels must rotate in a slanting direction, as shown in figs. 9 and 10. Thus the design is carried spirally round the tube. This inclination of the wheels gives a rotatory motion to the machine, and therefore, whilst thus operating, it is necessary to fix it on a metal disc, which is fitted on to a second disc, having a projecting collar, round which it rotates whilst the tube is being drawn through.

These are the operations requisite for engraving, pressing, or embossing designs on any kind of metal tubes, and it is evident that

T. FEARN. PATENTEE,
BIRMINGHAM.

Fig. 1.

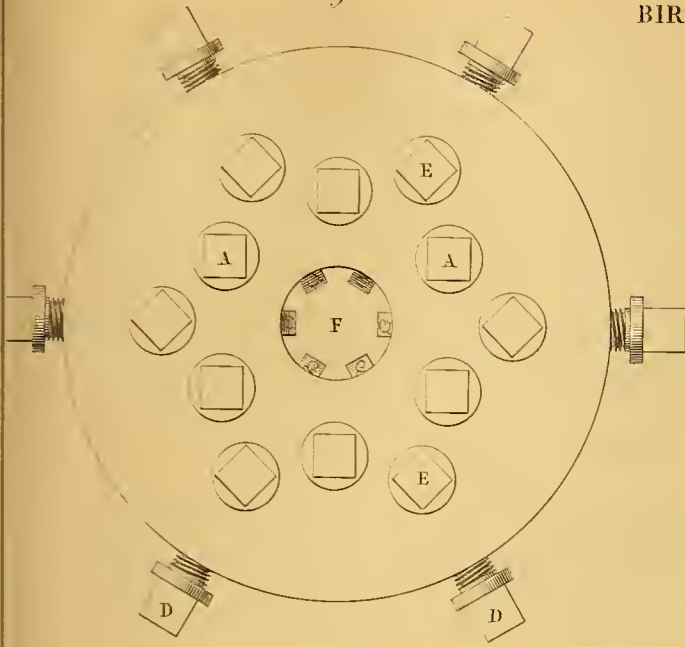

Fig. 3.

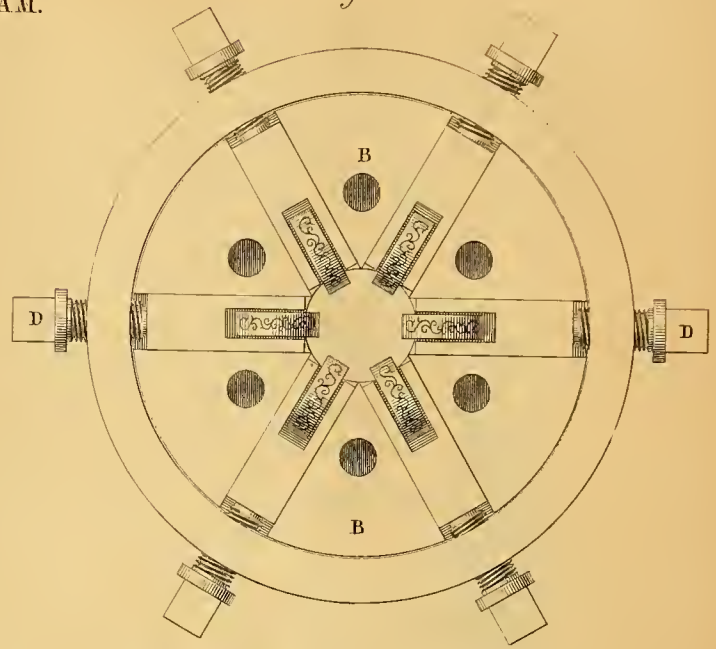

Fig. 2.

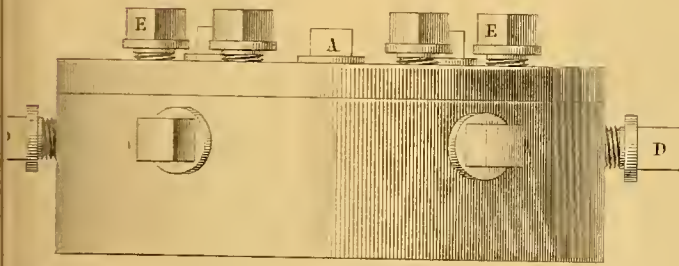

Fig. 4.

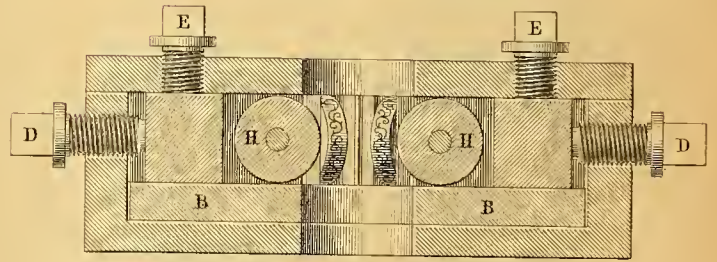

Fig. 5.

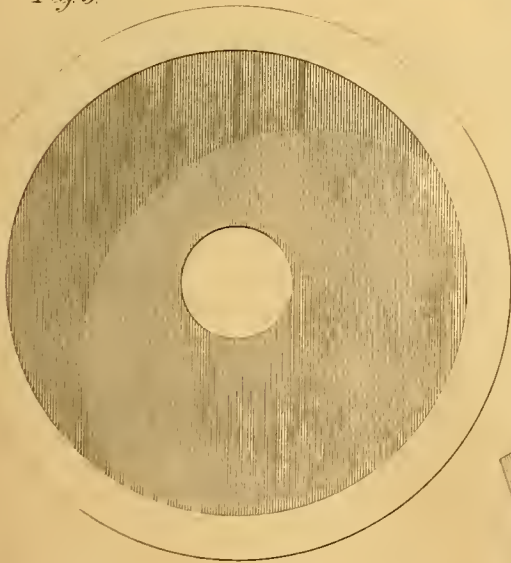

Fig. 11.

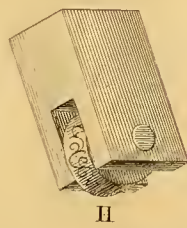

Fig. 7.

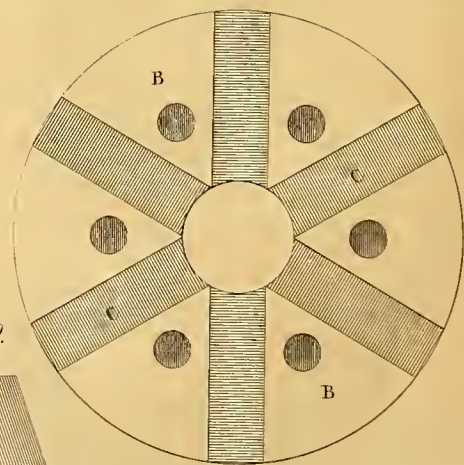

Fig. 9.

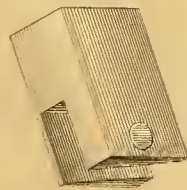

Fig. 10.

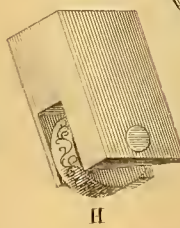

Fig. 6.

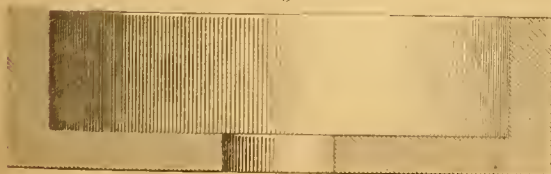

Fig. 8.



the same process will answer equally well for metal rods, the mandrel in that case being of course dispensed with. For the purpose of producing the same ornamentation on strips of metal, Mr. Fearn employs a somewhat differently constructed machine, though acting on the same principle. Between two standards, or holsters, is hung a long plain roller, parallel to which, a series of the bars or blocks, with their rollers attached, are hung in a trough, or hollow. The distance of these engraving rollers from the plain roller, is regulated by screw pins at the heads of the blocks, as in the machine shown in our plate; and their relative distances are governed by regulating screws acting on their sides, so that having impressed one series of designs by drawing a strip between the plain roller and the engraving rollers—the strip being kept in position by small grooved wheels at the sides—the operator can alter the position of the engraving rollers, and passing the strip through again, he can produce another series of designs between those already engraved. This may be repeated as often as may be desired, and hence a most extensive series of designs may be produced by a proper system of management.

GAILLARD & DUBOIS' "GAZOGENE," OR AERATED WATER APPARATUS.

We now present another novelty in aerated water apparatus, just introduced by Messrs. Gaillard & Dubois, of Paris. The main features of this arrangement consist in the employment of three distinct chambers, or receptacles, one being for the water to be aerated, a second to contain the effervescing powders, and a third to retain a small quantity of pure water, which, after the apparatus is closed, is allowed to fall upon the powders, thereby causing the evolution of the carbonic acid gas. Fig. 1

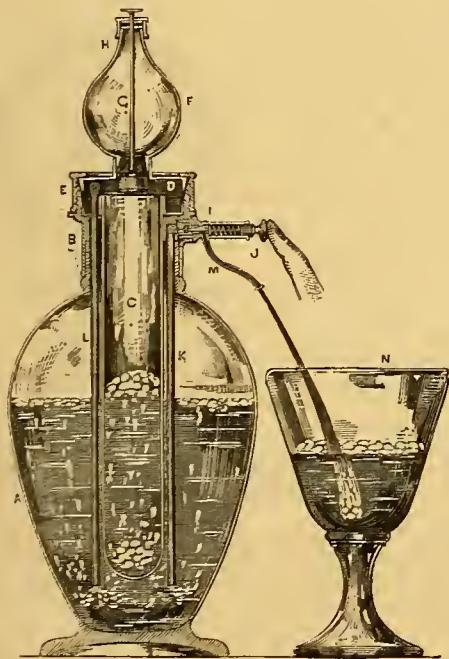

Fig. 1.

represents one modification of this ingenious apparatus. The water, or other liquid to be aerated, is contained in a glass bottle, A, of elegant shape, and formed with a wide cylindrical neck, to which a metal collar piece, B, is cemented. This collar is bored out to receive the long cylindrical glass vessel, C, like a chemical test-tube in shape, supported by a metal collar, cemented to its upper open end, and fitting into a recess in the collar, B. Above this, the collar, B, is bored out conically, to receive a conical lid, D, which is screwed down by the cap-piece, E, the joint being rendered hermetic by the introduction of a ring of leather or caoutchouc between the conical surfaces. The lid, D, has a central opening, into which is cemented the small glass vessel, F, resembling a hollow stopper from its shape and position. It is fitted with a conical plug, the spindle, G, of which passes through a small stuffing-box at the top, and has a button attached outside. The stuffing employed is a disc or washer of leather or caoutchouc, which is compressed by the screw-cap, H. Into one side of the collar, B, is screwed a species of siphon cock, J, consisting of a plug-valve, opened by the pressure of the finger on the external button, J, and closed by the action of a helical spring. The passage of this valve communicates with a tube, K, of small bore, reaching nearly to the bottom of the vessel, A. On the opposite side is another similar tube, L, descending to a like depth, and terminating above in a small rose, and in communication with the vessel, C, in which the gas is evolved. The manner of proceeding in using this apparatus is as follows. The cap, E, is unscrewed, and the three vessels are separated, when the largest, A, is filled to nearly seven-eighths of its capacity with the liquid to be aerated. The bicarbonate of soda and tartaric

acid, or other powders for producing the gas, are now put into the tubular vessel, C, which is then put into its place in the vessel, A. The vessel, C, is next filled with pure water, and the plug being tightly closed, it is placed in position, and the whole screwed together again. When it is wished to set the matters in action, the plug spindle, G, is depressed, and the water descends upon the effervescing powders, and the gas evolved in consequence finds its way by the tube, L, to the water below, impregnating it and passing through it, so as to exert a pressure on its surface, which, when the cock, J, is open, forces it up through the tube, K, and out by the spout, M, into the glass, N, placed to receive it.

In another modification of the apparatus, represented in fig. 2, the chamber, A, in which the carbonic acid gas is generated, and corresponding to the tube, C, in fig. 1, is placed between the two other vessels, B and C, instead of within the larger one. It has metal collar pieces above and below, by means of which it is screwed to the vessels, B C, leather or caoutchouc washers being employed to render the joints tight. The gas, when generated, finds its way down the tube, D, which has a cross slit at the top, too fine, however, to allow any water to get down. The tube, D, is enclosed in a second tube, E, of larger bore, both tubes reaching almost to the bottom, of the vessel, B. The last-mentioned tube, E, is in connection with the siphon-cock, F, and the pressure of the gas forces the liquid up the annular space between the tubes, D and E, and out by the cock, when the last is open. It will be observed that the plug in the uppermost chamber, C, opens upwards instead of downwards, as in the modification, first described. Either of these methods will answer the purpose, and the inventors also propose some other plans for opening the communication between the water receptacle and that for the powders. According to one of these, a loose valve opening upwards is used, connected by wires to a flat ring, which comes in contact, say, with the top of the vessel, C, in fig. 1, when the apparatus is screwed together, and is thereby caused to rise and permit the water to pass through. Again, a simple clack-valve may be adopted, which may be opened by a wire projecting up from beneath, and raising it when the apparatus is screwed together.

Fig. 2. A detailed technical drawing of a modified Gaillard & Dubois apparatus. It shows a large glass bottle (B) with a central vertical tube (D) and a smaller glass vessel (C) at the top. A siphon-cock (F) is attached to the side, and a plug valve (I) is at the bottom. A glass vessel (N) is shown to the right, containing aerated water.

Fig. 2.

FROST & CO.'S ECCENTRIC OR COMPENSATING STOP-COCK.

Messrs. Frost, Noakes, and Vincent, the well-known brass-founders of Whitechapel, are now making stop-cocks which they have lately patented under the name of "eccentric or compensating"—the points of advantage being the prevention of all external leakage, whilst the in-

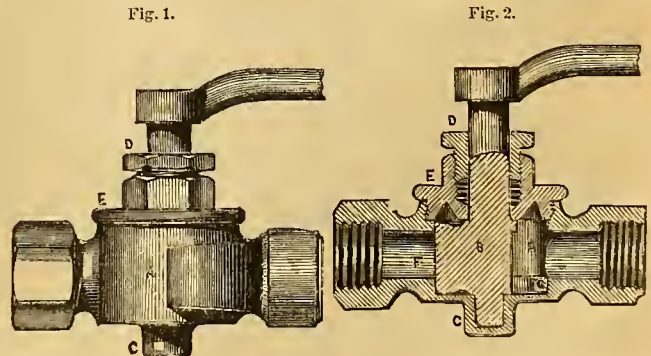

Fig. 1.

Fig. 2.

terior surfaces compensate for their own wear. Fig. 1 is an external, and fig. 2 a sectional elevation of this stop-cock; fig. 3 is a horizontal section, and fig. 4 is a separate elevation of the plug. The cock is represented as shut. The shell, A, is a wide cylindrical chamber of con-

siderable diameter, compared to the pipe or water-way on which it is placed. The plug, *B*, does not pass through the bottom of the chamber, its spindle simply working in a recess, or species of footstep-bearing, *C*, so that leakage is impossible at that part. The upper end of the plug-spindle passes through a stuffing-box, *D*, in the cover, *E*, which is screwed on to the chamber. The plug itself is in the form of a cylindrical segment, having its curved surface turned eccentric to the axis of the spindle, and the part of the internal

Fig. 3.

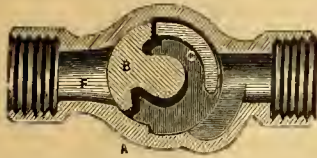

surface of the chamber, against which it works in closing the outlet passage, *F*, is also turned out eccentrically to correspond. It follows from this arrangement that the surfaces do not touch until the outlet is

just closed, so that the wear is reduced to a minimum, and what little there is is compensated for by the form of the parts, since, when the surfaces are at all worn, it will be merely necessary to turn the plug round a little further to obtain a perfect closing. A circular projection or stop, *G*, is formed on the plug, and a corresponding stop is formed in the side of the chamber, *A*; these are to prevent the plug from being turned too far round when opened, and so impede the flow of the liquid. The side of the chamber opposite to the plug, when opened, is, moreover, scooped out to give a freer passage.

The arrangement obviously affords a full clear water-way, whilst the contact surfaces are peculiarly well disposed for the prevention of unequal wear.

Fig. 4.



RECENT PATENTS.

METAL FORGING MACHINE.

J. H. JOHNSON, 47 *Lincoln's Inn Fields, and Glasgow.*—*Patent dated December 22, 1852.*

Fig. 1.

This machine has been patented in this country on behalf of the American inventors, Messrs. H. and G. H. Richards. In it are accomplished all the

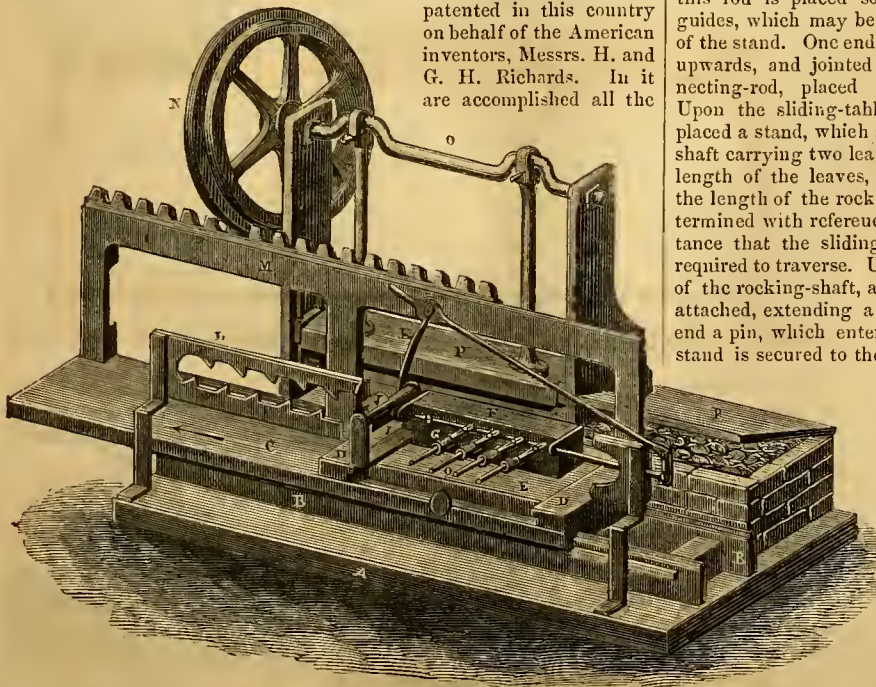

necessary movements of heating, holding, carrying forward, turning, and hammering, or striking, pieces of metal being forged, or worked, into any desired shape. The face of the hammer, or forging instrument, has a peculiar curvilinear movement given to it for the purpose of "drawing" the piece of metal under treatment; whilst the swages, or shaping dies, carried on the lower side of the hammer, have such

a form and position with relation to each other, that the heated bar, placed between them and the anvil, is made to assume a shape approaching nearer and nearer to the shape of the finished article at each successive blow of the hammer and traverse of the heated bar. Each bar, or piece of heated metal, is carried by a tubular holder, and is made to revolve partially at each stroke of the hammer, this motion being effected by a rack and tappet movement, or other convenient arrangement. The heat is derived from a small furnace fitted under the bars on a level with the anvil, so that the pieces of metal are kept hot during the forging operation. The stand which holds the bars has a forward intermittent movement given to it by means of a rack and differential worm; and the face of the hammer is made up of a series of swages, or shapers, arranged to act consecutively upon the bars—one swage striking the bar in one place, and the next a little further on in the bar, the swages being placed diagonally along the hammer-face. The hammer is worked by cranks on an overhead shaft, and, to give the required curvilinear movement to the hammer-face for "drawing," the hammer is supported by two pins, allowing it to turn slightly on its centres. When an article is to be forged flat, or thicker in one direction than the other, the swages are alternately long and short to suit the two sizes.

Fig. 1 of our engraving is a perspective elevation of the machine complete, and fig. 2 is a transverse vertical section to correspond. The machine is carried on a solid base-plate, *A*, on which are set two parallel horizontal bars, *B*, secured to each other transversely by ties. On the top of each bar is a rail, or rib, shaped to fit into a groove on the lower side of the moveable platform, or table, *C*. Over this table are placed two transverse guides, *D*, parallel to each other, and fitted to receive the ends of the sliding table, *E*, allowing the latter to traverse to and fro at right angles to the direction of the length of the platform, *C*. Along one side of the table, *E*, is a stand, or rest, *F*, bolted firmly down, and perforated laterally to receive the ends of the cylindrical holders, *G*, allowing them to turn freely. Each of these holders is bored out through its axis to hold the bar of metal to be worked, the bar being secured to its holder by a set-screw. Each of the holders is furnished with a handle, in which there is a slot for a pin, attached to the horizontal rod, *H*, to enter; this rod is placed so as to traverse in guides, which may be fastened to the end of the stand. One end of the rod, *H*, is bent upwards, and jointed to an inclined connecting-rod, placed directly above *F*. Upon the sliding-table, *E*, there is also placed a stand, which supports a rocking-shaft carrying two leaves, or teeth, *J*, the length of the leaves, in the direction of the length of the rocking-shaft being determined with reference to the distance that the sliding-table, *E*, is required to traverse. Upon one end of the rocking-shaft, an arm, *K*, is attached, extending a short distance upwards, and having at its upper end a pin, which enters a slot in the inclined connecting-rod. A bent stand is secured to the bed of the machine to support the fixed-rack, *L*.

Fig. 2.

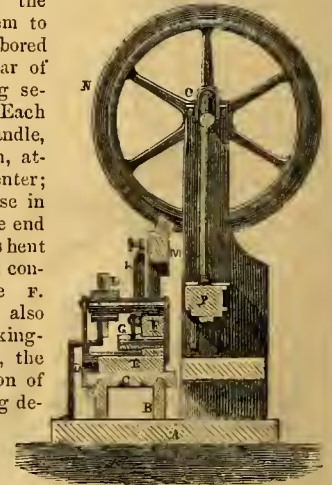

This rack, which is made of plate-iron, and is nearly as long as the machine, has a long slot, or opening, which is furnished with cams, or teeth, both upon its upper and lower edges, the teeth being of such number and form, and so placed with reference to each other, as to act in any required manner upon the leaves, *J*. To the horizontal traversing platform, *C*, there are affixed two or more upright standards, which support a bar, upon the top of which a rack, *L*, is bolted, and the teeth of the rack are so placed as to receive the tooth, *N*, of a worm-wheel which is attached to the shaft, *O*. One section of the tooth is placed upon the wheel in a

spiral direction, in such a manner as to give a progressive motion, by its action upon the rack, to the platform, *C*, during one part of its revolution; the other part of the tooth, or worm, being placed parallel with the sides of the wheel, allows the rack and platform to stand still during the remainder of its revolution. Motion is given to the hammer by means of vertical rods, connected to the crank-shaft. The hammer, *R*,

is so placed as to act upon one end of the bar of heated iron, *q*, which passes through the centre of the holder, each having a separate bar. The sliding-platform, *c*, which supports the bar-holders, is so placed, that the ends of the bars, *q*, may be exposed to the heat of a fire, *n*, placed at one end of the machine, the surface of the fire being at about the same level as the face of the anvil upon which the bars are forged. The bars may be advanced towards the fire, or withdrawn from it, by turning a screw, which moves the table back and forward, the position thus given to the table being such as to allow the proper length of the heated ends of the bars to be brought under the action of the hammer. At each end of the hammer there is a sliding-piece, upon the outer side of which there are two vertical grooves, adapted so as to fit, and move freely upon the two vertical guide-bars, which are securely fastened to the frame of the machine. At each end of the hammer, there is a round hole, fitted to receive a round pin projecting from the end of the hammer, and properly secured in the sliding-guide. The hammer and guide, being thus attached to each other, will traverse the same distance while rising and falling, whilst, at the same time, the face of the hammer, or the face of a swage, attached to the bottom of the hammer, will have an alternate motion to the right and to the left, at each revolution of the cranks. If preferred, the pin may be firmly fixed in the end of the hammer, and left free to turn slightly in the sliding-guide. If the pin be placed nearer to the top of the hammer, the deviation of the bottom or face of the hammer, when at its lowest point, from a horizontal line will be greater; if placed lower, it will be diminished.

The extent of this deviation from a horizontal line, as well as the shape of the curve, described by a marking-point projecting from the end of the hammer, will also depend upon the position of the crank, with reference to its centre of motion. It will also be observed, that the extent of the rocking motion to and fro is greater when the pin is near the top of the hammer, and less when it is near the bottom. Therefore, by changing the position of the pivot, the drawing action of the hammer, or swages, can be increased or diminished. The face of the anvil, which is about the same length as the hammer, may be horizontal, or it may be inclined from the front to the back, or inclined in the opposite direction, the direction of this slope serving to increase or diminish the drawing action of the hammer. The series of bars, *q*, being heated to the proper temperature, the machine is started, and the revolution of the wheel, *n*, moves the rack and platform in the direction of the arrows. As the rocking-shaft moves forward, the bottom leaf, *j*, comes in contact with one of the teeth, on the lower part of the fixed rack, *l*, by which the shaft is turned a short distance, and, by means of the arm, *k*, the connecting-rod above, the rod, *n*, and bar-holder arm, the holders and the heated bars are turned one quarter round. While the bars are being turned in this way, the hammer is rising, the tooth, *x*, no longer acts upon the rack, the platform stops, and the hammer descends upon the heated bars. As the hammer rises, the platform moves forward, the upper leaf, *j*, comes in contact with the upper rack-teeth, and the bar is turned one quarter round in the opposite direction, in readiness for the next blow of the hammer. In case the section of the article to be forged is not quadrangular, the heated bar is turned more or less, as required, instead of being turned one quarter round, as above described.

After the whole series of bars, or rods, have been operated upon, it becomes necessary to move the sliding platform back to its first position, in order that the bars, *q*, may be again heated at the fire. This may be effected by raising the driving-wheel out of gear with the rack, and sliding the platform back by hand; or the direction of the motion of the wheel may be reversed, whilst it remains in gear with the rack, to produce the same effect. Previous to sliding the platform back, the inclined connecting-rod must be detached from the arm, *k*, in order that the leaves, *j*, may be placed nearly horizontal, so that they may pass between the rack-teeth.

The form and use of the swages, by which the article to be forged is gradually drawn out, and brought to the required form, by the successive blows of the hammer, is now to be explained. In forging the handle of a square file, tapered uniformly to a point, swages, attached to the lower side of the hammer, are used, the prominent parts of which are not in a line with each other, but are placed diagonally, in such a manner that the heated bar is struck by the first face, by which it is slightly drawn, or extended. The bar is then turned one quarter round, and is moved opposite to the second face, where it receives another

blow; and so on, throughout the series of swages, each of which brings it nearer to the required tapered form, until it receives the last blow, upon its extreme point, from the face of the last swage.

The diagonal line, upon which the faces of the swages are placed, will differ, as to its direction, with reference to the parallel sides of the hammer, according to the rapidity with which the drawing is to be effected. In case the article forged is to be cut off after receiving the last blow, a cutter is added to the series of swages for this purpose, and a suitable cutter is placed below it upon the anvil. It will be noticed, that if the forged article is cut off, the cut will not be perfectly square, as the cutter partakes of the peculiar curvilinear motion of the hammer, to which it is attached; but if the article is required to be cut off square, the cutter may be fastened to the sliding-guide, which is placed between the end of the hammer and the vertical guide-bars.

BLOCK-PRINTING FOR CALICO.

R. SANDIFORD, *Tottington Lower End, Bury.*—*Patent dated Nov. 15, 1852.*

Mr. Sandiford's invention is more especially intended for printing handkerchiefs, when two or more colours are used, its object being to facilitate the manual operation of block-printing, and insure perfect "register." The mechanism consists of a printing table, with an elastic surface of the usual kind, carried on a frame which also supports the colour sieves, one at each end, if two colours are used. The printing blocks are connected together by a frame, so as to be capable of lifting together, and they are attached to the frame by four parallel links set on fixed centres, the length of each link being equal to half the distance of the centre of the sieve, from the centre of the printing table. With this arrangement, the blocks are so adjusted, that whilst one is in the act of printing, the other is being furnished with colour. The printer himself has merely to lift the blocks alternately from one sieve to the other, and back again, whilst two mixers supply the sieves with colour, and a boy winds up the fabric as it is printed. The perfect "registering" of the pattern is secured by the action of the parallel links, the peculiar steadiness of hand hitherto indispensable, being thus rendered quite unnecessary.

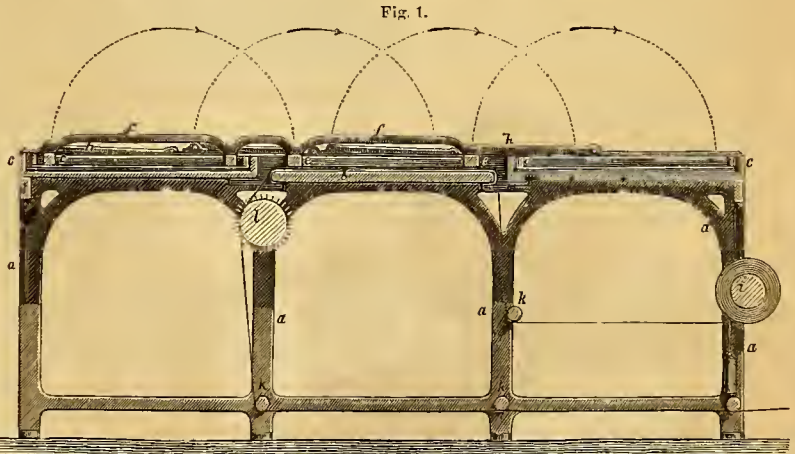
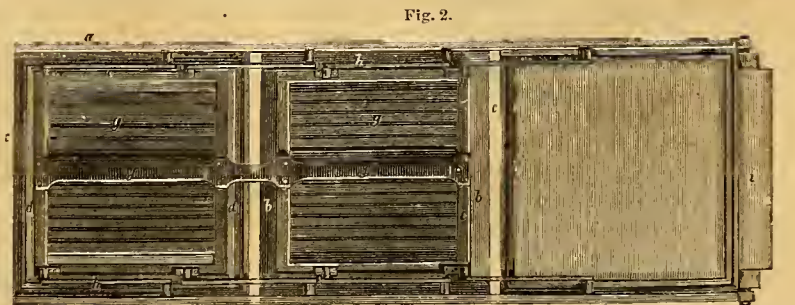

Fig. 1 of our engravings is a longitudinal section of the apparatus, as contrived for printing with two blocks. Fig. 2 is a plan cor-



responding. The main framing consists of the standards *a*, supporting the stone printing table, *b*, the upper surface of which is covered with a blanket, or other elastic material. The frame, *a*, also carries the boxes, *c*, in which the floating sieves, *d*, are placed; *e*, are the

blocks, formed of light bars, instead of being solid, and connected together by a hand-rail, *f*, by means of which, also, they are lifted when required; at *g*, are the parallel links connected to the blocks, and capable of moving upon the fixed centres, *h*, attached to the frame, *a*.

The roller upon which the calico is wound, before printing, is shown at *i*; *k* are tension rollers, and *l* is a roller (furnished with pins upon its surface), by means of which the cloth is wound forward as it is printed. This roller, *l*, may be turned by means of a winch handle at one end, or in any other convenient manner, and may, if desired be connected with an index for ascertaining and indicating the number of impressions of the pattern or design, or the length of cloth printed.

One block, *e*, is represented as printing the design, and the other as furnishing itself with the red colour in the right hand sieve; and it

is clear that if the blocks are raised by means of the hand-rail, *f*, and moved towards the left, until the block, *e*, rests upon the left-hand sieve, containing the blue colour, the other block will then be printing the red colour. The movements of the blocks and links describe an arc of about 180°, as represented by the dotted lines in fig. 1. Another modification is shown in the plan, fig. 3, where the invention is represented as adapted for printing with four blocks, each of the four sides of the table being furnished with a sieve and a block. In this arrangement, it will be seen that the blocks are not connected together, but are provided with two links each—the fixed centers of the links being exactly in the centre between the table and the sieve. Each block is, in this instance, worked separately, but the parallel links act exactly in the same manner as in the preceding case. All the parts are lettered to correspond to the preceding figures. By the use of what are commonly called "spring tubs," instead of the sieves in both the arrangements, a very great variety of colours may be printed with ease, accuracy, and expedition.

Fig. 3.

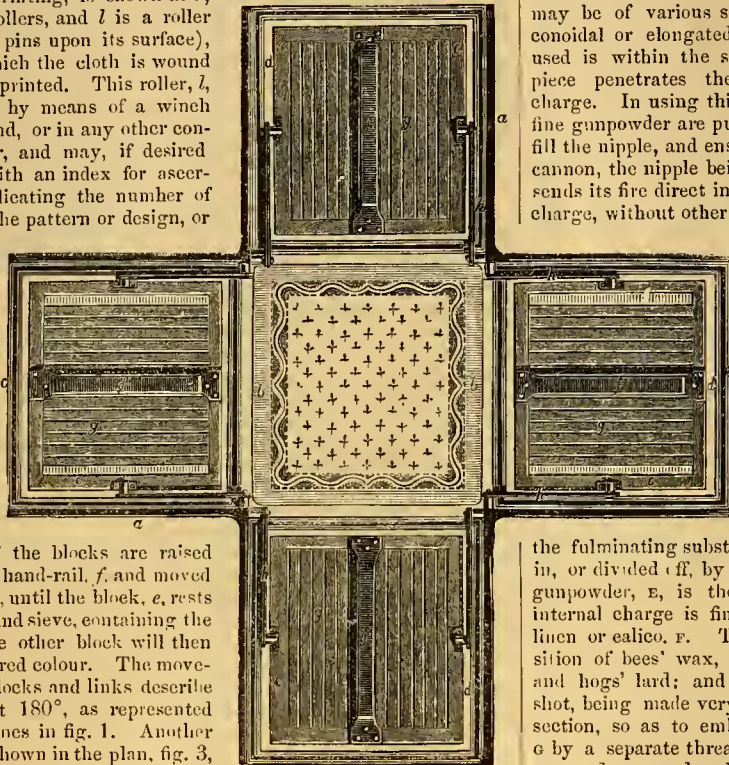

placed over it; after this, the gunpowder is put in, and over that is fastened a circular patch or disc of thin linen or calico, greased with a preparation of bees' wax, spermaceti, and oil; or, instead of this, oxide of zinc and hogs' lard may be used; and the charge may be wholly of gunpowder, instead of a compound of fulminates. The patch encloses the base of the shot, and goes half way up its sides. The shot may be of various shapes, but it is preferred to make it cylindro-conoidal or elongated, somewhat like an acorn. The entire charge used is within the shot, and the fire from the percussion cap of the piece penetrates the centre of the greased patch, and fires the charge. In using this projectile with the common rifle, a few grains of fine gunpowder are put into the piece, besides the ball charge, merely to fill the nipple, and ensure firing; but with Norton's improved model rifle cannon, the nipple being in the centre of the breach, the percussion cap sends its fire direct into the centre of the retaining patch, and fires the charge, without other assistance. On firing, the explosion expands the

shot, to fill up the bore of the piece, or the grooves of the rifle; or, for rifled cannon, the shot may have rifle projections to begin with, so that the explosion, on firing, may entirely fill up the grooves.

Figure 1 of our engravings is a side elevation of the improved shot, drawn to the full size; and fig. 2 is a longitudinal section of the same, to correspond. In this example, the cylindro-conoidal shot, *A*, of wrought-iron, is formed with a conical chamber, *B*, to receive the charge, which is represented by the dotted mass, *C E*. The part marked *C*, in the narrow end of the conical chamber, is

the fulminating substance; and this portion of the charge is then shut in, or divided off, by the thin partition, *D*, of thin tissue paper. The gunpowder, *E*, is then filled in over this partition, and the entire internal charge is finally secured by the external cover-piece, of thin linen or calico, *F*. This cover is prepared with a waterproof composition of bees' wax, spermaceti, and neats'-foot oil, or oxide of zinc and hogs' lard; and it forms a secure lid across the mouth of the shot, being made very considerably larger than the area of the shot's section, so as to embrace the cylindrical part, where it is tied on at *G* by a separate thread, the cylindrical part of the shot being slightly recessed, or reduced in diameter at this point, to give a better hold. In this shot the percussion fire from the nipple of the piece penetrates right through the fabric of the charge cover, and the consequent internal explosion expands the shot, or containing shell, so as to fill up the bore of the piece to the greatest nicety. The shot is rifled by being flattened off at four sides; but it is equally obvious that the desired effect will be secured as well in smooth bore shooting. The base of the shot being, as it were plastic, is not liable to fracture, but at once fully accommodates itself to the bore of the piece. The charge within the shot may be level with the base or open end of the cylinder, or it may project slightly beyond this line, as the calico covering may be pierced through the touch-hole, like other cartridges. These shots, or modifications of them, may be made of malleable cast-iron, or wrought-iron; or, for small arms, they may be made of lead, by mechanical pressure. And instead of charging each shot loosely, the charge may be put in, in the form of a cartridge, when it is to be fired. The annular groove at *I*, on the conoidal part of the shot, is intended for the spring tongs to lay hold of in drawing the shot.

When intended for small arms, the shot is made of lead, without any external rifle projections, as the internal explosion causes the soft metal to expand well into, and fill up the rifle grooves of the piece. But for rifled cannon, the shot has proper rifle projections upon it, to fit easily into the rifle grooves, malleable cast-iron being employed, so that the expansion fills up the grooves very accurately; and instead of carrying the cover-piece, *F*, up the sides of the shot, it may be tied down into an annular groove, close to the base or open end of the shot.

In using malleable cast-iron for rifle cannon shot, Capt. Norton proposes to adopt Mr. Ommaney's process, leaving the conoidal head of the shot hard, like common cast-iron; whilst the after cylindrical part possesses the complete malleability so necessary for the perfect expansion on firing. In speaking of this system of projectiles, Capt. Norton compares the action to that of a bow and arrow, the rifle being the bow, and the cylindro-conoidal shot the arrow, or rather arrow-head, or missile of modern warfare. This is a very apt assimilation.

The gallant inventor is still energetically pursuing his courses of experiments; and his shot, we hope, will shortly form a part of every soldier's ammunition, and be found in every rifleman's cartouche-box.

HOLLOW EXPANDING CYLINDRO-CONOIDAL SHOT.

Capt. JOHN NORTON, *Cork*.—*Patent dated December 2, 1852.*

Fig. 1.

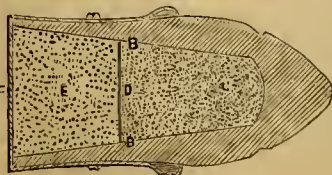
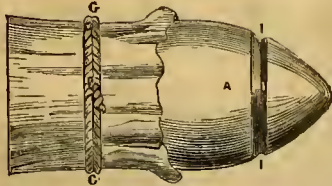

Fig. 2.

Capt. Norton, well known for his numerous improvements in gunnery and projectiles, and as the undoubted originator of the "elongated rifle shot," commonly, but improperly, designated under an unimportant modification, as the "minié" shot, has introduced, under this patent, a shot of great simplicity and value, which, without any complication, carries its own charge within itself, and expands most effectively in the act of firing.

The charge is composed of a safe fulminating powder and common gunpowder, in about equal proportions. Various fulminates may be used; the fulminate being first put into the hollow of the shot, and a circular piece of thin tissue paper is then

placed over it; after this, the gunpowder is put in, and over that is fastened a circular patch or disc of thin linen or calico, greased with a preparation of bees' wax, spermaceti, and oil; or, instead of this, oxide of zinc and hogs' lard may be used; and the charge may be wholly of gunpowder, instead of a compound of fulminates. The patch encloses the base of the shot, and goes half way up its sides. The shot may be of various shapes, but it is preferred to make it cylindro-conoidal or elongated, somewhat like an acorn. The entire charge used is within the shot, and the fire from the percussion cap of the piece penetrates the centre of the greased patch, and fires the charge. In using this projectile with the common rifle, a few grains of fine gunpowder are put into the piece, besides the ball charge, merely to fill the nipple, and ensure firing; but with Norton's improved model rifle cannon, the nipple being in the centre of the breach, the percussion cap sends its fire direct into the centre of the retaining patch, and fires the charge, without other assistance. On firing, the explosion expands the shot, to fill up the bore of the piece, or the grooves of the rifle; or, for rifled cannon, the shot may have rifle projections to begin with, so that the explosion, on firing, may entirely fill up the grooves.

STEAM AND WATER GAUGES.

G. FIFE, M.D., Newcastle-upon-Tyne.—Patent dated November 5, 1852.

Dr. Fife's invention consists in combining a water gauge, pressure indicator, and alarm, in one apparatus. We have engraved the arrangement by which this is effected. Fig. 1 is a lateral elevation partially in section, and fig. 2 is a section at right angles to fig. 1,

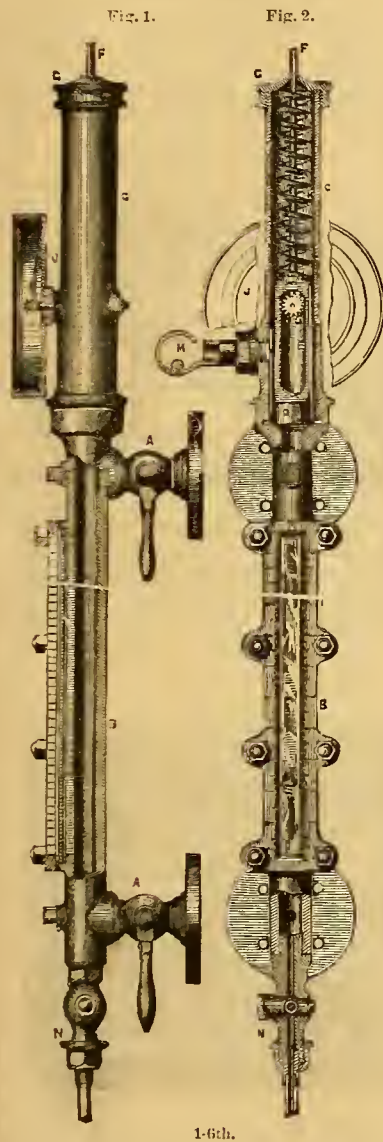

but showing the water gauge in elevation. At A A are the branch cocks communicating with the boiler in the usual manner, and having between them the water gauge pipe, B, fitted with a glass or talc face. This glass face is protected from the effects of undue pressure, and rendered tight by strips of vulcanized india rubber, in the manner already adopted for windows. To the upper end of the water gauge pipe, is screwed the cylindrical casing, C, inside which, at its lower end, is fitted a small accurately bored cylinder or tube in communication with the top of the water gauge pipe, and consequently with the boiler. In this inner cylinder a steam tight piston, D, works, carrying on its upper side a long slotted piece, E, terminating in a guide spindle, F, passing through the screw-cap, G. One side of the slot in the piece, E, is formed into a rack and gears with a small pinion, H, on a transverse spindle, passing through the side of the casing and carrying an indicating finger, I, in front of a graduated dial in a small flat cylindrical case, J, protected by a glass face. Inside the casing, C, above the slotted piece, E, and abutting against a collar framed on the end of this piece, is a helical spring, K, the other end of which abuts against the inside of the screw-cap, G. This spring serves to regulate the movement of the piston, and causes it to descend on a decrease of the pressure

acting on the under surface of the piston. It is obvious that, by means of the rack and pinion, the pressure will always be accurately indicated on the graduated dial. Should the pressure become too great the consequent rising of the piston, D, will uncover a lateral outlet in the cylinder opposite the tube, L, which communicates with the alarm whistle, M, and in consequence the steam will rush through and sound this whistle, thereby calling attention to the state of the boiler. A small pipe and stopcock, are fitted to the lower end of the water gauge pipe, at N, for blowing off and clearing the pipes. The contrivance is convenient and well suited for its purpose.

MANUFACTURE OF STARCH.

E. TUCKER, Belfast.—Patent dated 6th December, 1852.

Mr. Edward Tucker of the extensive "Royal Exhibition Prize Starch and Ghee Works," Waring Street, Belfast, is the patentee of these improvements, which relate essentially to the application of certain salts, both alone and in combination with mineral acids, for the more effective separation of the pure starch from the glutinous and other foreign mat-

ters with which the starch itself is originally combined; as well as to the neutralising the injurious effects of the vegetable acids generated in the process of starch making, and the increase of the produce of good starch from a given quantity of wheat. By the same means, Mr. Tucker is also enabled to render any pure water suitable for starch making, although in its natural state such water may be ill adapted for this purpose.

After the wheaten meal, or reduced grain, has been submitted to the usual process of fermentation, and has been washed, to separate the bran from the rest of the elements of the treated substance, the starchy liquor is run into a receiver or vat, where it is allowed to remain for about the space of thirty-six hours for precipitation. The supernatant liquor is then run off or removed, and the precipitate is broken up. Then a solution of sulphate of soda, or Glauber's salts, in boiling water, is prepared, in the proportion of about twelve pounds weight of the salt to one ton of the wheat under treatment, and after cooling down, this solution is poured into the precipitated starch, and the vat being filled up with water, the entire contents are thoroughly mingled and incorporated by stirring. The mass is then allowed to stand for twenty-four or thirty hours perfectly quiescent. In the subsequent process, technically known as the "fine shift," when the water and slimes are removed, the operator employs another solution of the same salt, but in smaller proportion—about three pounds weight being applied to the produce of one ton of wheat. At this stage is also used, in combination with the sulphate of soda, a portion of sulphuric acid, in the proportion of about one quart of the acid to the produce of four tons of wheat. The acid, in a diluted state, is poured gradually into the vat, and the latter is then nearly filled up with fresh water, the whole contents being thoroughly mixed by agitation. When the starch has been precipitated, it is finished and prepared for sale and use in the usual way.

Although Mr. Tucker prefers to use the materials and the proportions which we have described, he states that he has found sulphate of magnesia, muriate of soda, and other salts and acids, available for a similar purpose. This general process renders all pure water suitable for manufacturing starch, however soft and unsuitable it may be originally. The pure starch is also better separated from the glutinous constituent of the grain, whilst the manufactured starch is superior in purity, sweetness, strength, fineness of texture, and whiteness, as compared with all starch made in the usual way, and the yield is greatly increased.

GAS-LIGHTS APPLIED TO VENTILATION.

R. BROWN, Manchester.—Patent dated October 20, 1852.

The object of Mr. Brown's invention is to obtain an efficient ventilation of buildings and apartments through the agency of the heat generated by the gas-lights employed for illumination. The engraving represents

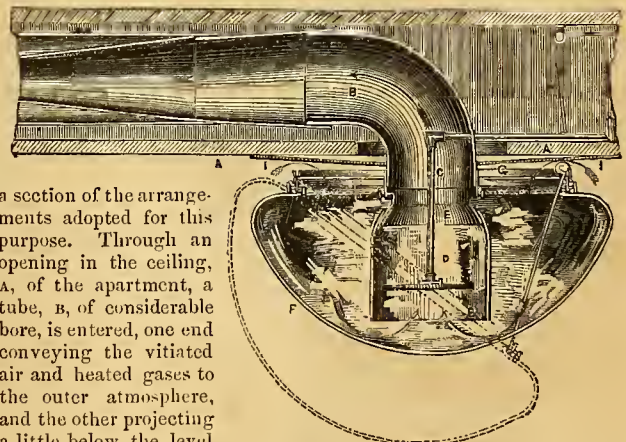

a section of the arrangements adopted for this purpose. Through an opening in the ceiling, A, of the apartment, a tube, B, of considerable bore, is entered, one end conveying the vitiated air and heated gases to the outer atmosphere, and the other projecting a little below the level

of the ceiling. The gas pipe enters at one side, and is bent so as to hang perpendicularly in the centre of this tube, and carrying an annular burner at its lower extremity. The burner is surrounded by the glass chimney, D, which is supported by its top on the metal cone piece, E, secured to the lower extremity of the tube, B, by screws. The whole is further surrounded by a hemispherical glass shade, F, having its mouth uppermost, and its upper edges only a few inches below the level of the ceiling. This shade is attached, at its upper edge, to a metal ring, G, by means of screws, and is hinged to a second ring, H, firmly fixed to the tube, B, by radial arms. The cord, I, is for lowering the outer shade to the position indicated by the dotted line, for the purposes of lighting or

cleaning, and a highly-polished metal reflector is added at 1, to increase the effect of the light. As the obvious effect of this arrangement, the current caused by the gas flame will take the direction of the arrows. The air will be drawn in from the highest and most vitiated strata in the apartment, and, passing through the flame, will be carried off along the tube, 2, whilst an inlet for fresh air must be provided at some low part of the room.

ROTATORY ENGINE AND PUMP.

THOMAS ELLIOT, *Soho Foundry, Preston.*

This contrivance, which is intended for the threefold purpose of a motive engine, a pump, and a meter, reminds us of Mr. Davies' gas exhauster.* Its outer case consists of a couple of short horizontal cylinders, set together and joined at A, with a free opening between them. Each section is bored out to a true cylindrical working surface, to receive the two elliptical pistons, B, which are set and connected to work in concert with their major and minor axes at right angles, just like the old differential plan of "elliptical wheels," for causing one uniformly rotating shaft to actuate a second, in gear with it, at a variable rate; that is to say, their working surfaces keep in constant contact with each

Fig. 1.

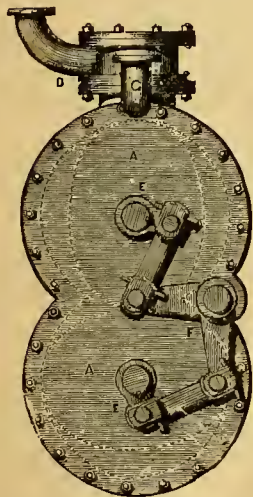
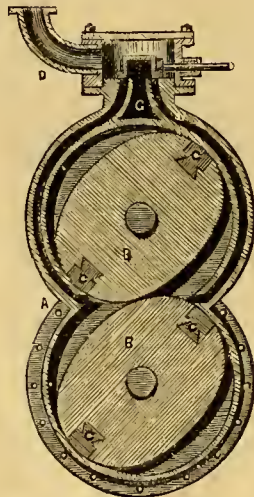

Fig. 2.



other during the revolution; and to keep up a steam-tight action on the interior of the working chambers, spring packing pieces, c, are let into the contact ends. As arranged for working as a steam-engine, the steam enters by the curved branch, d, at the top, and finds its way into one or other of the curved side ports, just as the regulator slide-valve may be set; this slide, with its spindle passing out through a stuffing-box in the valve chest, being the only detail required by the attendant for starting, stopping, and reversing. The pistons revolve with their ends in contact with internal set up plates, and the shafts of each pass out transversely through these plates, and through the outside case, and each carries a short crank, e, so that the two may be geared together without toothed wheel-work. This is simply and ingeniously effected by linking each crank-pin to one arm of a bell-crank lever, f, working loose upon a stationary stud centre. Spur wheels may, of course, be used instead of this crank and connecting-rod plan, but the latter is far preferable, as it works smoothly and at any possible speed. As represented in fig. 2, the regulator is closing both thoroughfares; but on shifting it either way, the steam passes down the open port, enters the cases, and urges round the two pistons, whilst the used steam exhausts up the opposite thoroughfare, and escapes through the covered port and the hollow of the valve into the exhaust branch, g. Stuffing boxes only are required in the external shell or cylinder, as corresponding gland pieces are cast on the outsides of the set up plates for the shafts to pass through; and to keep the pistons tight, a ring of india-rubber is passed all round the peripheries of the set up plates.

The patentee possesses a working model running at 2,000 revolutions per minute; and he states that, as speed is no object in this engine, the "common road locomotive" has now a fair chance of really coming into

use by its aid. For factory purposes, he would ramify the steam pipes through the different storeys, and place a separate engine in each room, doing away with all continuous shafting.

GLASS BOTTLES AND JARS.

GEORGE WILSON, *York.*—*Patent dated 20th November, 1852.*

The object of this invention is to simplify the operation of manufacturing glass bottles and jars, with externally screwed necks to receive a capsule stopper. The patentee produces the required effect in the act of forming the bottle, by means of the apparatus represented in our engravings. Fig. 1 is a sectional elevation, and fig. 2 a plan of it. On the

Fig. 1.

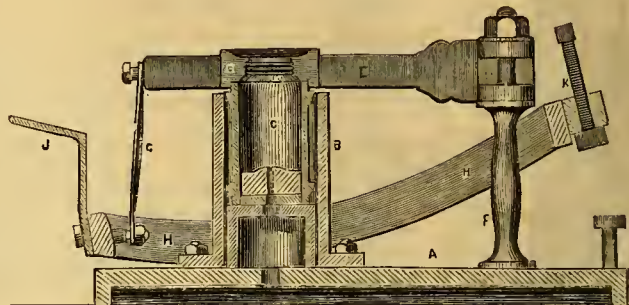

base plate, A, a cylindrical box, B, is bolted, inside which is placed the mould, C, which shapes the lower part of the bottle, and forming a continuation of this mould are a pair of dies, D, carried by the horizontal levers, E, which are hinged together, and work on a centre pin attached to the standard, F. The opposite ends of the levers, E, are connected by cross rods, G, to a rocking frame, H, oscillating on pins working in the

Fig. 2.

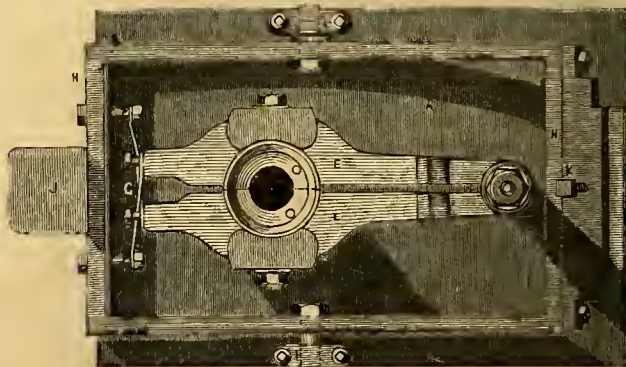

bearings, I, attached to the base plate. To the front end of the rocking frame a tread plate, J, is bolted, by means of which the workman draws down the levers, E, at the same time closing them firmly together by the powerful action of the cross straps, G. An adjustable stop pin, K, is fitted to the hinder and heavier end of the rocking frame to prevent it from being depressed too far. The glass blower proceeds in the ordinary manner, gathering a ball of molten glass on the end of his tubular iron rod, and introducing it into the mould, the levers, E, being apart. He then closes the dies by the action of his foot, and blows out the glass until it takes the form of the mould, when he allows the dies to separate, and withdraws the bottle, and finishes it in the usual manner.

MECHANIC'S LIBRARY.

American Engineer's Assistant, 4to., 28s., cloth. O. Byrne.
Encyclopaedia Britannica, Vol. II., Part 1, 4to., 8s., sewed.
Lunar Theory, Elementary Treatise on the, 8vo., 5s., 6d., cloth. Godfray.
Marble Mason's Assistant, sq., 1s., cloth. W. H. Wyeath.
Naval and Mail Steamers of United States, 2d edition, £2. 10s. Smart.
Photography, On the Art of, 4th edition, 12mo., 6s., cloth. H. C. Snelling.
Practical Brass and Ironfounder's Guide, foolscap 8vo., 5s., cloth. Larkin.
Tables of Areas of Circles &c., 2d edition, 6s., cloth. Todd.

REGISTERED DESIGN.

THROTTLE VALVE.

Registered for MESSRS. HILLS & WHITTAKER, Engineers, Oldham.

This valve is a combination of the old "hutterfly" disc, with the equilibrium arrangement, forming a very neat contrivance for throttling purposes, as it gives a clear steam way, whilst it is worked with the greatest possible ease. Our engraving represents it in vertical section.

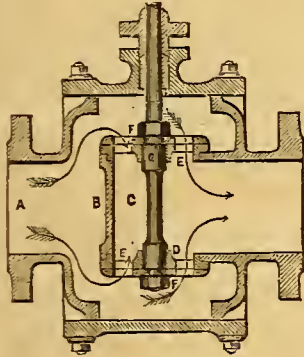

The steam is supposed to be entering by the branch, A, into the cylindrical shell, B, cast with the line of pipe, and covered in with top and bottom caps, to form a complete valve chest. In the centre of this chest is the cylindrical brass chamber, C, cast solid all round, with the exception of an opening on the discharge side, and fitted in at top and bottom by stationary brass discs, D, slotted through all round with radial steamways, E. These discs are covered externally by moveable discs, F, screwed upon the spindle, G, and perforated to correspond with the stationary discs.

The shell, C, is supported in the inner projecting branch of the discharge passage, so that when the shifting discs are turned partially round, the openings, E, are brought into correspondence, and the steam passes through them on each side, as pointed out by the arrows. This fills the chest, C, and the steam thence passes off along the branch to the right. The spindle, G, is passed out through a stuffing-box in the top plate of the outer shell, for connection with the governor in the usual way.

CORRESPONDENCE.

SELF-MOVING TURN-TABLES.

The object of the following contrivance is to shorten the time required for turning locomotives, and to relieve the driver and fireman from the labour of working the turn-table. It has also a decided advantage, in point of cost, over plans where water power is employed, since the motive agent is the locomotive itself.

In the accompanying drawing, A, fig. 1, is the turn-table, which only



Fig. 1.

differs from those in use from being without the hand gear. It has a large pulley, B, keyed on its main spindle, actuated by an endless chain, C, which passes over a guide-pulley, and thence through a weight, F, and round a second guide-pulley at the bottom of a well, G. The chain then returns up over a third guide-pulley, not shown, and back again to the pulley, B. The links of this chain are of the peculiar section shown in fig. 2, being square at one end, so as to form a species of ratchet chain. The weight, F, through a central opening in which the chain passes, is fitted with, say, four pairs of palls, to catch upon the square ends of the chain links, so that in descending the weight carries the chain along with it, and thereby turns the table, being sufficiently great to overcome the friction when the engine and tender are on it. In being drawn up, the weight will obviously pass over the chain without moving it, owing to the peculiar form of link. The palls should be so arranged, one pair above the other, that the weight may not possibly fall more than an inch in any case. The weight, F, has attached to it a rope, R, which passes over a guide-pulley, G, and thence over a return pulley, H, between the rails on which the locomotive approaches. It is there attached to a small carriage, I, running along a channel formed for it between the rails. This carriage is so placed as that a projection on the smoke-box of the locomotive shall come in contact with it, and carry it forward towards the turn-table. This action will obviously draw up the weight, F, ready to turn the table by its descent.

The channel in which the carriage, I, runs is inclined downwards close to the table, and when the locomotive reaches that point, as shown by the dotted lines, the carriage, I, descends and gets free from it; but being formed with an inclined top, it does so very gradually. When it is quite clear, the weight, no longer receiving support from the rope, R, commences to descend; but before it passes through more than an inch, its palls will catch the links of the chain, C, so that the weight will be suspended on the chain; and as soon as the engine and tender are on the table, and it is set free, it will turn during the descent of the weight. The same action will obviously draw back the carriage, I, ready for another stroke.

Near the bottom of the well, E, and above the lower guide-pulley, some elastic material should be interposed to receive the fall of the weight, if it should by any accident be let go. The rope, R, also, should have a portion of its length elastic, to soften the shock of the first contact of the locomotive with the carriage, I. From the peculiarity of the links the endless chain must be put on without a twist, and the guide-pulleys should be formed with sockets, that the links may lie square upon their peripheries.

May, 1853.

KENNETH.

[Mr. G. P. Renshaw, of Nottingham, has also turned his attention to this subject; and, as a sequel to our correspondent's proposition, we append engravings of Mr. Renshaw's design. Fig. 1 is a plan of a portion of a turn-table with the actuating apparatus attached. Fig. 2 is a detailed side view, showing the apparatus for working the endless screw movement. A is the table; n, two rollers mounted on shafts, turning in bearings, or otherwise the shafts may rest on anti-friction wheels, if desirable. The rollers are so disposed, that when the locomotive engine is run on to the table, the driving-wheels of such engine can be placed in contact with the top of the peripheries of such rollers, and so as to rest on them. To give the driving-wheels a tendency to rest on the top of such peripheries, the shafts are placed a little out of line. One of the rollers is attached by a universal joint to a shaft, D, having an endless screw, E, adapted to a worm-wheel, F (shown by dotted lines), the latter being connected with the usual gearing by which the turn-table is actuated. The shaft, D, is also connected with a lever, G, and the latter by a shaft, H, with a detent, I. To the detent,

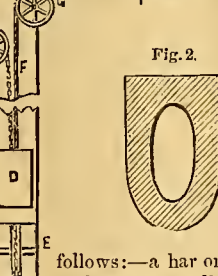
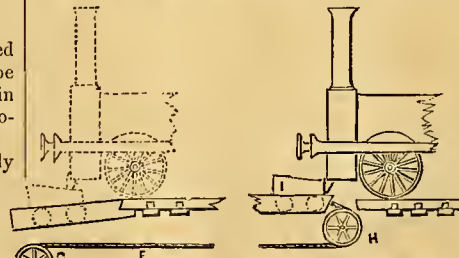

Fig. 2.

I, a weighted lever, J, is attached by a joint, and so arranged as to be capable, by the action of gravity, of throwing the endless screw, E, in and out of gear with the worm-wheel, F, by moving the shaft, H, and lever, G. The detent, I, falls at intervals into recesses, or notches, in the fixed structure surrounding the table, one of these being shown at K, whenever the line of railway upon the table coincides with the lines communicating with the same. It is so arranged that when the detent, I, is raised out of the recesses, K, the endless screw, E, is thrown into gear with the worm-wheel, F, by the intervening shaft, H, and lever, G; and contrariwise when the detent, I, falls into the recesses, K, the endless screw is thrown out of gear with the worm-wheel. The action is as follows:—a bar or other impediment being thrust in the way of the spokes of the roller, B, or the revolution of the same being otherwise prevented, the locomotive engine, with or without the tender attached, is run on to the table, as in fig. 1, the driving-wheels of the engine being made to rest on the rollers, B; the engine is then fixed in this position by the application of the brakes on the tender, or by scotchies. Next, the weighted lever, J, is thrown aside to the position as dotted, so as, by the action of gravity, to raise the detent, I, out of the recess, K, and to throw the endless screw, E, into gear with the worm-wheel, F. This being done, motion is communicated by the locomotive to its driving-wheels, which, by their insistent weight, cause the revolution of the rollers, B; and, by means of the endless screw, worm-wheel, and other appendages, cause the revolution of the turn-table with its superincumbent locomotive. Before the turning has been completely accomplished, the weighted lever, J, is thrust over to the opposite side, and, when the lines of railway coincide, the detent, I, is forced into the recess, K, thereby

cesses, or notches, in the fixed structure surrounding the table, one of these being shown at K, whenever the line of railway upon the table coincides with the lines communicating with the same. It is so arranged that when the detent, I, is raised out of the recesses, K, the endless screw, E, is thrown into gear with the worm-wheel, F, by the intervening shaft, H, and lever, G; and contrariwise when the detent, I, falls into the recesses, K, the endless screw is thrown out of gear with the worm-wheel. The action is as follows:—a bar or other impediment being thrust in the way of the spokes of the roller, B, or the revolution of the same being otherwise prevented, the locomotive engine, with or without the tender attached, is run on to the table, as in fig. 1, the driving-wheels of the engine being made to rest on the rollers, B; the engine is then fixed in this position by the application of the brakes on the tender, or by scotchies. Next, the weighted lever, J, is thrown aside to the position as dotted, so as, by the action of gravity, to raise the detent, I, out of the recess, K, and to throw the endless screw, E, into gear with the worm-wheel, F. This being done, motion is communicated by the locomotive to its driving-wheels, which, by their insistent weight, cause the revolution of the rollers, B; and, by means of the endless screw, worm-wheel, and other appendages, cause the revolution of the turn-table with its superincumbent locomotive. Before the turning has been completely accomplished, the weighted lever, J, is thrust over to the opposite side, and, when the lines of railway coincide, the detent, I, is forced into the recess, K, thereby

fixing the turn-table, and at the same time throwing the endless screw, E, out of gear with the worm-wheel, F. The turning being accomplished,

Fig. 1.

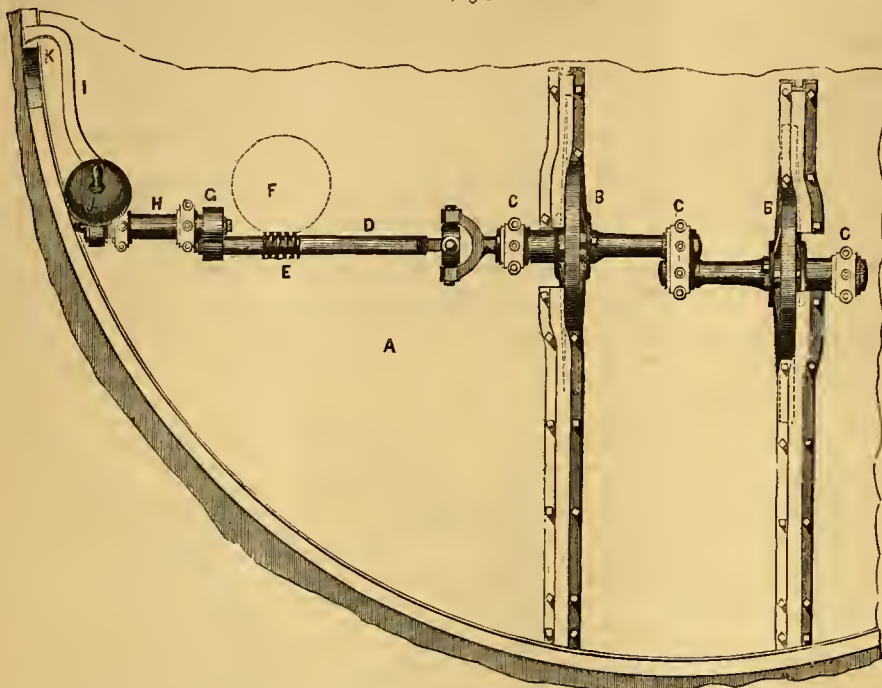

GOODYEAR'S (U.S.) PATENT FOR VULCANIZING CAOUTCHOUC.

Your notice in the April number of your Journal, under the head of "Goodyear's (U.S.) Patent for Vulcanizing Caoutchouc," though right in the main, might yet mislead. It was not the patent for vulcanizing which was refused an extension, but it was a patent for the combining of sulphur with caoutchouc, and is commonly known here as the sulphur patent.

Thus the combination of sulphur with caoutchouc was invented by Nathl. Hayward, and assigned to Charles Goodyear, and by him patented in 1839; this is the patent which the commissioners refused to extend.

The vulcanizing process was invented by Charles Goodyear—patented in 1844, and the patent was reissued in 1849. It is for a triple compound of caoutchouc, sulphur, and white lead, subjected to a high degree of artificial heat.

After the expiration of the sulphur patent (in September next), there will be another nice point for the lawyers, as to whether caoutchouc and sulphur, cured by steam heat, will be any infringement of Goodyear's patent of 1849, it being alleged that Goodyear was not the first discoverer of the use of steam heat for this purpose.

GEO. M. KNEVITT.

New York, April, 1853.

WHEELER'S COMBINED SAFETY VALVE, WATER GAUGE, AND ALARM.

the revolution of the rollers is temporarily prevented, and the engine may then be run off the table as usual. In any case a friction brake may be substituted to temporarily prevent the revolution of the rollers.

Fig. 2.

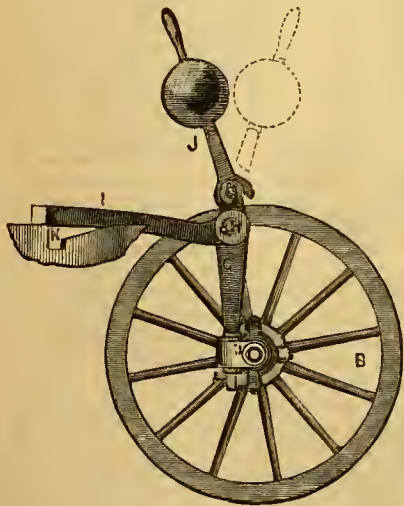

For turning coupled engines, a pair of rollers may be employed under each driving-wheel, partially or wholly connected with the actuating mechanism of the turn-table. To provide for turning coupled engines, in which the position of the driving-wheels is not adapted to the distance between the rollers, hand-gearing in the usual form may be applied to the same table, so that such table may be worked either automatically or by hand, as convenient. Any or all of these improvements may obviously be adapted to traverse tables.—En. P. M. JOURNAL.]

In boilers fitted up with this contrivance, the engine attendant is prevented from tampering with the important appendages on which the safety of all steam boilers so much depends, whilst all complication of levers and stuffing-boxes is done away. It is entirely self-acting, and the engineer has no communication with either of the indicators when in action. The sketch exhibits the arrangement in vertical section. At A,

is a perforated dome, for the escape of the blow-off steam, and beneath this dome is a valve, B, on the top of a chamber, C, containing the main safety valve, D, resting on a flat face, to prevent sticking. This valve, D, is weighted by the cast-iron ball, E, linked to the valve tail. The shell containing these valves has a side branch at F, for conducting steam into a small chamber beneath the whistle, G. When the steam gets higher than the point necessary to blow the whistle, the accumulated pressure lifts the valve, N, and opens an escape through the dome above. At N, is a brass rod working with its upper end entered into a glass tube above, the lower end having a copper ball float, J, resting on the boiler water surface. This rod carries a small ball or a pin working freely between the prongs of a lever, K, the other end of which is fast on the plug of a stop-cock, governing a steam way through the pipe, L, between the safety valve chamber and the whistle. As this float rises or falls two inches either way, it admits steam from the boiler to act on the whistle, and thus gives notice of derangement of the water level. The brass indicator, M, of the glass tube, the perforated dome, A,

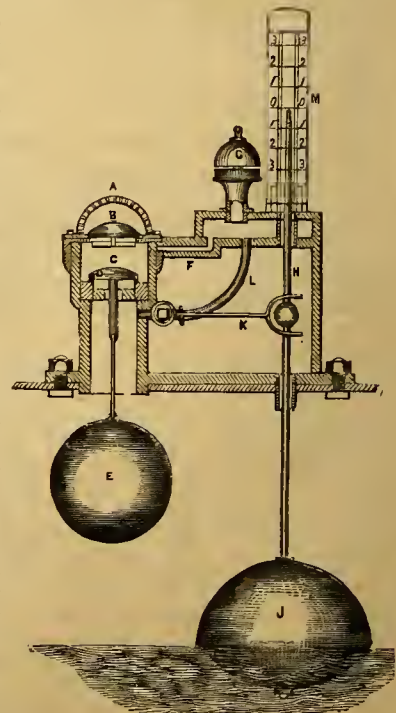

THE LATERAL ACTION OF THE SCREW PROPELLER.

Your correspondent, Lewis Gompertz, refers to the action of the screw upon steam vessels. If a screw steamer floats perfectly upright with the screw at rest, she will be slightly lopsided upon its being set in motion, caused by the reaction upon the vessel. If the order is to 'go ahead,' her starboard side will slightly rise, and port side lower; and upon going astern her port side will rise. The effect is, however, very slight. Upon a rough calculation, the effect of the screw upon H. M. S. Agamemnon, going ahead, would be the same as placing a weight of 16 cwt. on the deck, close to the larboard bulwarks. I have not seen the screw of the above-named ship, but of course conclude it to be a right-handed one.

Clifford's Inn, June, 1853.

THO. MOY.

and the whistle, *e*, are all the parts exposed to the eye, the remainder of the details being concealed in the steam chamber. The apparatus is intended to work either with the valves alone, or with the whistle alone, or with the two combined.

Oxford, June, 1853.

T. WHEELER.

AN ILLUSTRATED DEFINITION OF PERSPECTIVE.

As a misunderstanding of perspective still very generally prevails, and so many cheap educational, as well as more commanding works, are being introduced into general circulation, embracing this important subject, the sound or unsound principles of which publications will be relied on by those purchasers who desire to become acquainted with useful knowledge, I hope to do a public service by giving a simple and comprehensible illustrated definition of the science of perspective.

The art, or practice, of perspective can only be acquired from working all the rules of the genuine science, as more than the character of the subject cannot be communicated by description and illustration.

I have long since laid down and published ultimate rules for every case in rectilinear and curvilinear representation, which any one may acquire, without the aid of a master, from my work, entitled the "Science of Vision, or Natural Perspective." The misunderstanding of perspective arises from the two principles of optical and geometrical representation being confounded with each other. The skill of producing correct sections (in any direction) of any solid form is the fundamental knowledge of an experienced draughtsman, in every branch of mechanics, arts, and science; and, in the first place, I shall refer to the diagram, exclusively, as the means of producing the geometrical shape or outline of any section required.

Suppose a piece of wood to be of the shape of figure 1, and it should be

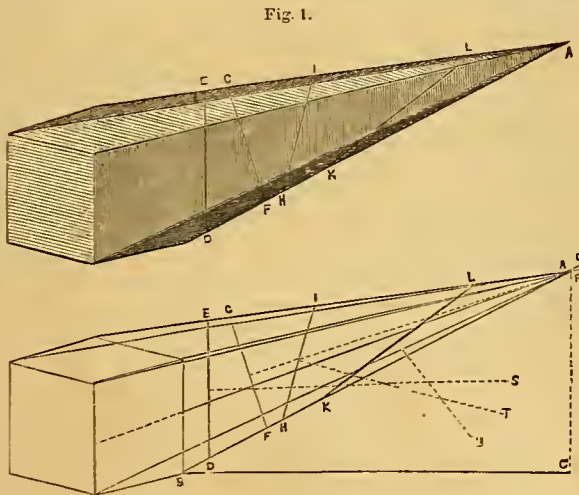
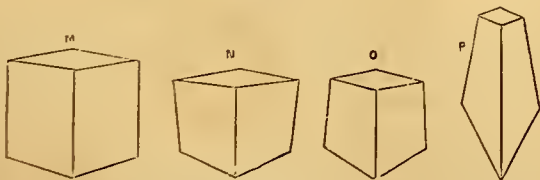

Fig. 2.

required to be cut through the sections, *dc, fg, hi, kl*, what would be the exact geometrical outline of these cuts? The first, *dc*, would be like the figure *m*, and the others like *n, o, p*, (fig. 3.) My simple plan produces

Fig. 3.



the same geometrical figure (without vanishing points) of the perpendicular section, *dc*, as that produced by the usual theory of the only section allowed in perspective; and this coincidence proves its mathematical accuracy. If the other sections, *fg, hi, kl*, of fig. 2, oblique to this ground-line, *dc*, be each drawn in separate diagrams, at right angles to other ground lines, as this section is, the current methods, with vanishing points, and mine, without vanishing points, prove the mathematical accuracy of them also. It is a simplification of the usual method of finding accurate geometrical sections, and being done without

vanishing-points, within the space of the drawing-board, it is extremely convenient for practice, and effects a saving of time and drawing instruments.

These geometrical sections show, that the parallel lines of the object represented foreshorten and converge in every direction of geometrical representation; and these fundamental characters, arising from angularity of position, is the cause of these effects (inseparable from the vision), which will explain why there cannot be such a theory as parallel perspective.

By observing the outlines of the geometrical sections, *mno p*, it will be seen, that irrespective of perspective or vision, *de* being a section parallel to the upright edges of the object, and perpendicular to a conventional ground line, that the perpendiculars of the representation, *m*, are parallel uprights; that the section, *fg*, being oblique to that ground line, the fig. *n* converges downwards; that the figure of section, *hi*, diverges downwards, or converges upwards; and the same with the section, *kl*.

Foreshortening and convergence are inherent principles in sectional geometrical representation, but have never been recognised as inherent principles in perspective representation. "He that hath eyes to see, let him see." When fixed on the situation of the lines, *de, fg, hi, kl*, these, and all other sections, form in the eye, at *a*, a figure like *n*, and do not appear like their geometrical shapes, except the eye changes its place, and views them from as many different points, *stuv*, perpendicular to the centre of each sectional line; and it is remarkable, that the only one of these perpendiculars which directs itself to the eye at *a*, is the equalized section, *fg*, forming the right base of an isosceles and axis of vision, and therefore must be the only true plane of the picture for faithfully representing objects as seen by the eye, which has always been the proposed object of the art of perspective.

Suppose a solid cube, and an eye (fig. 2) to be placed, so that the distances from *a*, or place of the eye, to the corners of the cube, make an identical pyramidal form, as the piece of solid wood, which may be modelled by attaching fine threads to seven of the corners, and bringing them to a point, according to my original invention for giving ocular evidence of geometrical sectioning and perspective by models. By perforating outlines, drawn like *mno p*, on card-board, and passing the strings through the points at the end of each line, and bringing them to a point at the defined distance, these figures will all lie in, and fit the sections, *de, fg, hi, kl*, without bending any of the threads out of the straight line, giving thereby ocular proof of the perfect accuracy of the art of sectioning geometrically. The acquirement of the easy practical rule for sectioning, in any case, annihilates intricacy and difficulty.

To understand perspective representation, and clearly to comprehend the difference between that and geometrical representation—if the eye be placed at the point, *a*, every one of these strung sections will coincide with each other, appear alike, and exactly cover all the lines or edges of the cube. As they are all unlike geometrically, but all look alike to the eye at *a*, we must refer to the eye for a reason for making unlike things appear alike, and find that it arises from the position of the object, or cube, relative to the vision, which can receive from it but one effect, or outline, with the affixed data. These distances from the ends of the lines of the cube are all unequal, but are equalised by the construction of the eye (the effects of which the mind ought to conform to), in horizontal and transverse directions through the axis of vision, and the image, or apparent figure of the object, is defined on the plane, posterior surface, of the iris, which is the true seat of vision. For, as all the lines from an object cross through a point, *a*, in the eye, and the spherical form of the eye makes the rays, *ag, ar*, of equal length, the inverted image made on that part in the eye is reflected on the iris, which always adjusts itself parallel to the chord, *gr*, which is always parallel with the section, *fg*, at right angles to the axis of vision, and the inverted image is described upon it by inverted reflection, in the same position as the object looked at.

As the angles of these threads are always the same at the point, *a*, although the points in the sections are so differently apart geometrically—on account of the angles being identical, the image in the eye of all of them will be, like the image out of it, formed on the section, *fg*. This optical section may always be readily distinguished, and found by equalising the distances, *ga, fa*, which give the section parallel to the plane of the iris, or natural plane of the picture, if accurately represented on a plane surface.

For want of the distinction being made between optical and geometrical representation, has arisen all the mystery and misapprehension of this valuable knowledge. And as the theory and practice of perspective still stands, and is still fostered on rising genius, the only section for which rules are given is the geometrical one, *de*, or that which is perpendicular to a real or imaginary ground line, *bc*, (fig. 2.) If any

student requires to define any other section than this conventional perpendicular one, there are no common rules in any work extant for doing so; so that they are imperfect, in a practical business point of view, and sadly limit the usefulness of sectioning, irrespective of the scientific importance of exact or natural perspective in science and the fine arts.

It is singular that such eminent mathematicians, as Dr. Brook Taylor, Dr. Malton, the learned Jesuits, and so many distinguished foreigners, should all of them confine the rules of perspective to one geometrical section (out of the many that may be cut), and which is not at right angles to the axis of vision, although that is properly made an imperative condition of their theories, and which can only be carried out by the optical section, *f. g.*

Natural perspective, which alone demonstrates the truth of photographic representation, or sun-drawing, and accounts for the foreshortening and convergence of perpendiculars, makes so great a change in the theories of art and science, which, being only interesting and beneficial to artists and scientific men, a rapid advancement cannot be expected (especially as old theorists never give way and promote improvements), as the population generally do not want the knowledge themselves for the purposes of their avocations, although so much, in reality, depends on skill and talent, originating from such knowledge, and which produces that improvement and variety, so universally demanded for the benefit of commercial enterprise, and for the gratification of the luxury of wealth.

The science of optics has never been properly treated. There is nothing wrong in the geometry, when considered in the abstract, but as they are not the principles of vision, the advantages of perspective and a practical theory have never been known to science or art.

Newtonian science says—"Optics is that part of natural philosophy which treats of vision, and the various phenomena of visible objects, by rays of light, reflected from mirrors, and transmitted through lenses, which constitute the subject of the most delightful science of optics." "The principal things considered are, the rays of light;" "the glasses by which things are reflected and refracted;" "the theorems, or laws, relating to the formation of the image thereby;" "the nature of vision, and the structure of the eye;" and "the structure and use of the principal optical instruments."

The chief stress is laid upon rays of light, and their geometrical action on lenses and mirrors, instead of the optical effects on the eye. We may be over-philosophical, if we limit the understanding to a secondary part of an important subject.

"The angle of incidence is equal to the angle of reflection geometrically; but philosophy, which has an eye to see with, knows there is no such law in the rays and reflectors without vision, which creates the angles of incidence and reflection, for the rays fall perpendicular to the surface of the reflector, without any angle, when there is no spectator in the case. As the eye moves, the angles of incidence and reflection alter, and follow its creative law; but as the science of optics is treated without this primary consideration, no one sees beyond their nose. The theorems, or laws, relating to the formation of the images of objects, are laid down by the laws of light and glasses, and not by the eye. The nature of vision and structure of the eye is only introduced to corroborate the theorems of rays and reflectors, but it would have led to less mystery, and more useful knowledge, if the converse had been the course pursued, and that the action of light, lenses, and reflectors, had been made only useful to explain the theoretical and practical formation of the visible images.

True philosophy bows respectfully to the sound geometrical principles of the abstract science of optics, but has no respect for its practicability; for it is only the skeleton of that beautiful figure, which, in its full and perfect form, rises before us, adorned with taste and judgment, on our gaining a practical knowledge of natural perspective.

This knowledge has been proved to science for many years, and since its publication waggon loads of paper have been printed and circulated with the known deficiencies and uselessness of unoptical perspective; and when truth prevails, the wonder will be, how scientific authorities, so highly honoured in society, could sanction the diffusion of such impracticable science, without vindicating a perfect theory, and promoting a knowledge essential to genius, luxury, and commerce.

ARTHUR PARSEY.

HUSSEY'S AMERICAN REAPER IMPROVED.

The following account of my latest improved reaper may, perhaps, be interesting to the readers of the *Practical Mechanic's Journal*, the pages of which publication have presented so many different examples of this class of machinery to public inspection. I shall best explain the new arrangements by going a little into the details of the two former patents,

obtained since 1851. It will be remembered, that in the machine which I sent to the Great Exhibition, the cutter-rod, on which the blades are fixed, works in a groove formed by the platform-bar behind, and in front, by a small rod riveted to the guards, or fingers, and by the fingers at the bottom, the blades being fixed on the top of the cutter-rod. The experienced difficulty in this plan was, that whilst the choking matter, which was forced into the slots of the fingers, found a ready escape on the upper side of the blades—that on the lower side was arrested by the permanent-rod, in front of the cutter-rod—there being no escape for it, except by the way it got in, and to get out under the cutter-rod was impossible.

In my patent of July last, this was changed, and the cutter-rod removed from the under to the upper side of the blades, whilst the permanent-rod, forming the front of the groove, was dispensed with. The choking matter on the under side of the blade now escapes freely into the vacancy occupied before by the cutter-rod; and, should it incline to remain there, short spurs may project downwards from the under side of the blades, to keep the space clear. Another difficulty in the exhibition machine was felt in crossing ridge and furrow. The main driving wheel being between the sills, the bar of the cutting apparatus must necessarily be secured to the sills, either behind or before the wheel, thus inevitably bringing the cutters against a ridge, when the main wheel sank into a furrow. The remedy for this is described in my specification of October last. The main wheel is placed outside the sills, allowing the cutting bar to be secured to the sill in a position within the circumference of the main wheel, and bringing the cutters nearly into a line with the main axle, so that in crossing ridge and furrow, both the wheel and the cutters may rise and fall together. By placing the driving wheel outside the sills, the clay accumulating upon it in wet weather, cannot choke the toothed gearing, which is now securely protected. Again, when going parallel with the furrows, in bringing the cutters to cut near the ground, that part of the cutter-bar near the wheel would drag the ground when the wheel ran in a furrow. An offset is now made in the cutter-bar, allowing the sills to be several inches above the line of the cutters. The improvements, described under my patent of November last, are—that instead of the former plan, where the cutters were supported and guided whilst vibrating, by the guards or fingers, they are now supported by projections from the platform-bar, and do not necessarily touch the fingers, allowing the choking matter an easier escape under the blades. The size and shape of the blades are as before, but each has a central hole made through it, say $1\frac{1}{2}$ inch long and $\frac{1}{2}$ inch wide. The object of this is the prevention of choking, by the passage of the square edges of the apertures across the fingers, clearing out the choking matter as fast as it is forced in by the blade action. According to another plan for the same purpose, an indentation is made on one side of the blade—a corresponding projection being produced on the other side, either by pressing or swaging—just as paper is embossed between a die and its matrix, or counterpart. This indentation may be about 1-16th inch deep, and as it has square edges, these parts will operate on the choking matter in the same way as the holes—as the angular edges of the projections, or swells, will have a clearing effect on the other side. The advantage of this plan is, that instead of weakening the blade by cutting metal out of it, additional strength is actually given in the fact of changing the plane of its surface, as in fluting or reeding. Besides this, the indentation may be carried nearer to the point of the blade than the hole. The cutter is of cast metal, so that the spurs or supporters of the blades may be cast on and form part of the bar.

June, 1853.

OBED. HUSSEY.

REVIEWS OF NEW BOOKS.

TABLES OF CIRCLES, SPHERES, SQUARES, &c. By Charles Todd, Engineer. London: Longman, Brown, Green, & Longmans, 1853. Pp. 114. Second Edition.

The first edition of this useful assistant to mechanics and engineers was published so far back as 1826; and the present one is issued in consequence of its being long out of print, whilst it has been much sought for—numerous applications having been made to the author for a second edition. We cannot give a better idea of the value of the work than that conveyed by this brief sketch of its history. Such a book will work its way independently of the appreciating critic, and in spite of the fault-finder.

The author says very truly that—

"Works of this kind now become so essential, that it is almost impossible to get through the ordinary routine of business without their aid. It has ever been considered a desirable object to facilitate the practice, as well as the acquisition of knowledge. Hence the dili-

gence with which many eminent men have laboured, especially among mathematicians, to furnish the world with calculations and tables, to insure correctness with facility to those persons whose circumstances will not allow them to spend much time and pains in the mathematical department of their respective vocations. But among the many and various productions of this kind, we do not find any presenting mechanics or artisans in general with tables of the areas and circumferences of circles, at least on a plan and in a size sufficiently extensive and convenient to be of general utility, notwithstanding daily experience evinces the indispensable necessity of such a work; for the transaction of business has now become of such an urgent nature, that numbers of individuals find it necessary to be furnished, either in the desk or memorandum book, with written tables of this kind, which have cost them a great sacrifice of their valuable time, and yet these tables have been neither so correct nor comprehensive as to afford them the aid desired."

Some idea may be formed of the comprehensiveness of the tables, when it is stated that we have the areas and circumferences of circles for diameters advancing by sixteenths of an inch, as well as by tenths of an integer; the solidities and superficies of spheres for diameters advancing by eighths of an inch, and by tenths of an integer; and the areas and diagonals of squares for sides advancing by eighths of an inch. To these are added a very useful table of specific gravities, and a record of some important experiments on different qualities of iron.

The author also explains his method of calculating the tables, by which a vast amount of labour appears to be saved.

PROCEEDINGS OF SCIENTIFIC SOCIETIES.

INSTITUTION OF MECHANICAL ENGINEERS.

APRIL 27, 1853.

"On Coleman's India-Rubber Springs for Railways," by Mr. W. G. Craig, of Newport.

We have already noticed this ingenious invention.—See plates 107-8, page 154, Vol. V., *Practical Mechanic's Journal*. Mr. Craig's deductions, as to their advantages, are as follow:—

1st, *Reduction of Dead Weight*.—This item is more extensive than appears at first sight, since the reduction of weight is not confined to the springs themselves, but extends, in a greater or less degree, to a variety of other parts of the engine, carriage, or waggon, on account of the smoothness of their action. This is particularly advantageous in the case of cast-iron, whose liability to fracture consists, not so much in the weight it has to carry, as its inability to resist strains, jerks, and concussions; these are, however, nearly altogether deadened by the use of these springs, so that a motion uniformly smooth and steady takes the place of one that is very injurious to railway plant, especially to engines; and as the working portions of an engine are made extra strong, with a view to resist the concussions they are subject to with steel springs, it follows that when these are no longer allowed to operate, they may be made lighter, without in the least impairing their efficiency. The reduction in the springs themselves is, however, considerable; and the weight thus gained is valuable, particularly in the case of waggons, where it becomes available for tonnage. The amount of this reduction of weight varies, as shown by the following table, but may be taken on an average at from 3½ to 5 cwt. per engine, and the same for waggons.

COMPARATIVE WEIGHT OF INDIA-RUBBER AND STEEL SPRINGS.

Weight of Springs.	India Rubber.	Steel.	Reduction in Weight.
Engine-Bearing Springs.	Cwt.	Cwt.	Cwt.
India-rubber, 1½ cwt.....	4½	8½	4½
Iron Work, 3 cwt.....			
Steel Springs taken off.....			
Engine Hydro-Pneumatic Springs.			
India-rubber, 1 cwt.....	7	8½	1½
Iron Work, 6 cwt.....			
Steel Springs taken off.....			
Tender-Bearing and Draw Springs.			
India-rubber, ¾ cwt.....	2¾	11	8¼
Iron Work, 2 cwt.....			
Steel Springs taken off.....			
Carriage-bearing, Drawing, and Buffering Springs...	4½	9¾	5¼
Steel Springs taken off.....			
Waggon-bearing, Drawing, and Buffering Springs...	3½	8¾	5¼
Steel Springs taken off.....			

2dly, *Steadiness of Motion*.—This has been referred to before, and it may be added that the great steadiness of the engines with the India-rubber springs is the surprise of every one who has witnessed their performance upon the imperfect road on which they are worked.

3dly, *Durability*.—Although sufficient time may not have elapsed to test the absolute durability of these springs, yet during the time they have been in use, in consequence of the heaviness of the work, if deterioration had commenced ever so slightly, it would have been observable; but in a large number of the India-rubber cylinders that were examined, after being at work for various periods, varying from four to six months, in both engines, carriages, and waggons, in no instance was the slightest alteration visible from the day in which they were first used, nor the

slightest permanent contraction in length, or expansion in diameter perceptible: it may, therefore, be inferred that their durability far exceeds anything hitherto applied to the same purpose, and is fully equal to any reasonable expectation or requirement. The specimens before the meeting have been in use for the last five and six months, and corroborate this statement. The weight on each pair of the engine springs is from 4½ to 9½ tons.

4thly, *Saving in Repairs*.—The simple construction of these springs renders it almost impossible for any injury to happen to them, consequently little or no repairs are needed. As stated before, the cost of repairing the steel springs of fifteen engines for six months was £251. 9s. 9d. The cost of repairing the India-rubber springs of fourteen engines during the last six months was only £1. 18s. The saving in the cost of repairs is not confined to the springs alone, but the engine itself, the carriages and waggons to which they are applied, and even the permanent way, share the advantage. It is found that fewer chairs are broken, fewer rails (plates rather) are bent, less grease and oil is used for the bearings, and the cost of maintaining the waggons is reduced when India-rubber is used. It is inferred, with a considerable degree of probability, that from the absence of any jerk upon the axles, the tendency of the iron to become crystallized or altered in its nature, and suddenly fracturing so often complained of, and which has produced so many serious accidents upon railways, will, by the use of these springs, be nearly overcome, and the axles remain perfect for a much longer period, more especially as under the India-rubber springs they show no tendency to heat.

5thly, *Cost*.—The question of first cost does not properly belong to this paper, but it will be sufficient to state that a well-constructed India-rubber spring ought not, in any case, to exceed the cost of a steel spring of equal strength; but on the hydro-pneumatic principle it will be found to be considerably cheaper, especially for engines, amounting on an average to twenty per cent. saving on the old plan.

The foregoing remarks have been made chiefly with reference to bearing springs, but they apply equally to both buffer and draw springs; and in proportion to the extent in which India-rubber is used in place of steel, does the improvement in the rolling stock become apparent, and the benefits resulting from its use more strongly developed. The pneumatic buffers, it is considered, have been subjected to a peculiarly severe test, few railways in the kingdom possessing such disadvantageous circumstances. Almost every other description of buffer had been tried previously with the same want of success, until, from repeated failures, the attempt to obtain a permanent buffer was almost abandoned in despair, and solid blocks of wood were substituted for them in many instances. With these buffers, however, no failure has taken place, nor in any instance has their elasticity diminished in the slightest degree. In the accompanying table, the deflection of this description of buffer and the several kinds of springs, under different weights, is shown.

TABLE OF DEFLECTION OF SPRINGS.

Load.	Engine Single Spring.	Engine Triple Spring.	Engine Hydro-Pneumatic.	Waggon Spring.	Buffer Spring.	Draw Spring.
	Fig. 1.	Fig. 2.	Fig. 7.	Fig. 3.	Fig. 6.	Fig. 9.
	Ins.	Ins.	Ins.	Ins.	Ins.	Ins.
½ ton.	5/16	1/4	5/16	7/16	3/8	1
1st "	1/4	1/2	3/4	1 1/16	1/2	1 1/2
2d "	3/8	5/8	1 1/8	1 5/16	3/4	2
3d "	1/2	3/4	1 1/2	1 9/16	1	2 1/2
4th "	5/8	1	1 3/4	1 13/16	1 1/8	3
5th "	3/4	1 1/4	2	1 7/8	1 1/4	3 1/2
6th "	7/8	1 1/2	2 1/4	2	1 5/8	4

Before the application of India-rubber draw springs to the engines and tenders, the couplings were frequently breaking, and also the frame ends; but since their adoption nothing of the kind takes place. Such are the advantages of these springs that their adoption promises to become general, and it will be shortly, without doubt, as rare to meet with a waggon unprovided with a draw spring, as it was formerly to meet with one.

In working 15,000 miles, the cost of repairs is found to be reduced in the engines using India-rubber springs, in corresponding engines of the two classes, from 5¾d. to 3¾d. per mile, and from 7d. to 3¼d. per mile.

"On Railway Axle Lubrication," by Mr. W. B. Adams, London.

"On a New Lubricating Material," by Mr. John Lea, London.

"On Messrs. Cox & Wilson's Portable Single-Acting Steam Engine," by Mr. T. T. Chellingworth.

After the meeting, Messrs. Salt and Lloyd, of Birmingham, exhibited specimens of a new process for raising or stamping vessels, formed from sheets of iron, tin, and brass, by which greater economy and rapidity are obtained than by the ordinary process. A heavy ram of 1½ tons weight is raised by steam-power a short distance, of about a foot, between guides, having the convex die attached to the under side of the ram, and the concave die or matrix is secured to the bottom of the frame as in ordinary stamping; the edges of the flat metal plate to be raised or stamped are then forcibly held down upon the matrix by a metal ring pressed down by eccentrics, whilst the blow is struck by the ram falling and driving the die through the ring into the matrix, which it fits accurately, the pressure of the ring on the edges of the metal plate being so adjusted as to allow the plate to draw uniformly into the required form without the edges becoming puckered; the metal is stamped cold.

ROYAL SOCIETY.

JUNE 16, 1853.

"Experiments and Observations on the Properties of Light," by Lord Brougham, F.R.S. The noble author appears to be as indefatigable as ever in his researches in this most interesting matter. On the present occasion, he said he considered Newton's experiments to prove that the fringes formed by inflexion, and bordering the shadow of all bodies, are of different breadths, when formed by the homogeneous rays of different bands, to be the foundation of his theory, and would be conclusive if the different rays were equally bent. But experiments were shown to prove that this different flexibility really exists, and this had not been remarked by Newton. A most interesting discussion followed.

INSTITUTION OF CIVIL ENGINEERS.

MAY 24, 1853.

JAMES MEADOWS RENDEL, ESQ., PRESIDENT, IN THE CHAIR.

"Description of the Newark Dyke Bridge, on the Great Northern Railway," by Mr. J. Cubitt.

This bridge, for carrying the railway across a navigable branch of the river Trent, near Newark, was described as being erected at a point where the line and the navigation intersect each other, at so acute an angle, that although the clear space, measured at right angles, between the abutments, was only 97 feet 6 inches, the actual span of the girders was 240 feet 6 inches.

The structure consisted of two separate platforms, one for each line of rails, carried upon two pairs of Warren's trussed girders, each composed of a top tube strut, of cast-iron, opposing horizontal resistance to compression, and a bottom tie, of wrought-iron links, exerting tensile force; these were connected vertically, by alternate diagonal struts and ties, of cast and wrought-iron respectively, dividing the length into a series of fourteen equilateral triangles, whose sides were 18 feet 6 inches long.

The top tubes rested upon the apices of equilateral, or A frames, fixed on the abutments, and each pair of girders were connected by a horizontal bracing, at the top and bottom, leaving a clear width of 13 feet for the passage of the trains.

Each tube was composed of twenty-nine cast-iron pipes, of $1\frac{1}{2}$ -inch metal and $13\frac{1}{2}$ inches diameter at the abutment ends, increasing to 18 inches diameter with $2\frac{5}{8}$ -inches metal at the centre of the span,—the ends of the pipes being accurately turned and fitted, so as to give exact contact of the surfaces, where they were connected together by bolts and nuts.

The lower tie consisted of wrought-iron links 8 feet 6 inches long, of the uniform width of 9 inches, but varying in number and thickness, according to the tensile strain to which each portion was subjected; the abutment portions having each four links of 9 inches by 1 inch, and the centre-piece fourteen links of 9 inches by $\frac{7}{8}$ inch.

The diagonal tie links varied from 9 inches by $1\frac{1}{2}$ inch to 9 inches by $\frac{3}{4}$ inch, and, in order to accord with the relative strains, were distributed in groups of four, for the first three lengths from the ends, and then in couples for the next four lengths on each side of the centre.

The cast-iron diagonal struts had a section resembling a Maltese cross, the area being in proportion to the compressive force to which they were subject.

The bearing-pins at all the intersections were $5\frac{1}{2}$ inches diameter, carefully turned and fitting into bored holes.

The links of the lower tie were supported, in the middle of each length, by a pair of wrought-iron rods, $1\frac{1}{2}$ inch diameter, suspended from each side of a joint-pin traversing the top tube; and by means of nuts and washers they could be made to bear a portion of the weight of the platform of the bridge.

The trusses were so arranged, that all the compressive strains were received by the cast-iron, and all the tensile force was exerted by the wrought-iron; the proportions being such, that when the bridge was loaded with a weight equal to 1 ton per foot run, which considerably exceeded that of a train entirely composed of the heaviest locomotive engines used on the Great Northern Railway, no strain could exceed 5 tons per square inch of section.

The total weight of metal in each pair of girders, composing the bridge, was 244 tons 10 cwt., of which 138 tons 5 cwt. were cast-iron, and 106 tons 5 cwt. wrought-iron, which, with 50 tons for the platform, &c., made the total weight of each bridge 294 tons 10 cwt., or 589 tons for the whole structure; and the cost, exclusive of the masonry of the abutments, and of the permanent rails, but including the staging for fixing and putting together and the expense of testing, was £11,003.

In a series of experiments to test the stability of a pair of the trussed girders, at the works of Messrs. Fox, Hendersou, & Co., where they were constructed, the following results were obtained:—

With a weight of 446 tons regularly distributed, which was equal to $1\frac{1}{2}$ ton per foot run, plus the weight of the platform, rails, &c., lowered seriatim on the thirteen compartments, the ultimate deflection at the centre was nearly $6\frac{1}{2}$ inches.

With a weight of 316 tons, equal to 1 ton per foot run, plus the weight of the platform, &c., as before, the ultimate deflection at the centre was $4\frac{1}{2}$ inches.

When the bridge was fixed in its place, a train of waggons, loaded up to 1 ton per foot run, extending the whole length of the platform, caused a centre deflection of $2\frac{3}{4}$ inches.

The deflection caused by two heavy goods engines, travelling fast, and slowly, was $2\frac{1}{2}$ inches; and that produced by a train of five of the heaviest locomotive engines used on the Great Northern Railway, was $2\frac{1}{2}$ inches in the centre.

The proportions of the several parts of the structure were originally given by Mr. C. H. Wild, and had been only slightly modified by the author during the execution of the work.

BIOGRAPHICAL ACCOUNT OF DR. WOLLASTON.

By THOMAS THOMSON, M.D.

William Hyde Wollaston, one of the most eminent chemists that Britain has produced, was born on 6th of August, 1766. He belonged to a Staffordshire family, distinguished for several centuries for their successful cultivation of science. The well-known work, entitled "The Religion of Nature Delineated," was the production of his great-grandfather. His father, the Rev. Francis Wollaston, of Chapelhurst, in Kent, was an astronomer. He made an extensive catalogue of the northern circumpolar stars. He was the author of ten papers, chiefly astronomical, which appeared in the Philosophical Transactions between 1769 and 1796.

Dr. Wollaston was one of seventeen children, all of whom lived to the age of manhood. His mother was Althea Hyde, of Charterhouse Square, London. He was born at East Dereham, a village about sixteen miles from Norwich. After the usual preparatory education he went to Cambridge, and entered at Caius College, where he made great progress. He did not graduate in arts, but took the degree of M.B. in 1787, when he was twenty-one years of age. In 1793 he took the degree of M.D., being of the age of twenty-seven. At Cambridge he resided till 1789, devoting himself chiefly to astronomy—a taste which he probably imbibed from his father. He was chosen a fellow of Caius College soon after taking his degree, and this fellowship he retained till his death.

After acquiring the requisite preliminary knowledge, he settled at Bury St. Edmund's, in Suffolk, as a physician. But his success as a practitioner was so bad, that he soon after left that place and went to London. Soon after, a vacancy occurred in St. George's Hospital, and Dr. Wollaston and Dr. Penherton started as candidates for the office of physician. Dr. Wollaston was particularly ill qualified for canvassing, and almost, as a matter of course, was unsuccessful. This want of success he took so much to heart, that he renounced the practice of medicine, and declared to his friends that he would never write another prescription. Indeed, he never liked the profession; nor was it well suited to his peculiar turn of mind. He turned his attention to science, and having discovered a method of welding the grains of platinum into metallic bars, became a manufacturer of this metal on an extensive scale, and gradually acquired a handsome fortune.

He has been accused of avarice, but apparently without reason. His brother wrote him to request him to apply to the Ministry of the time being, for some situation (probably in the church) on which he had set his heart. Dr. Wollaston replied that he had never applied for anything for himself, and could not think, therefore, of applying for another. But, continued Dr. Wollaston, if the enclosed bill be of any service to you, you are perfectly welcome to it. This enclosure was a bank bill for £10,000.

He was elected a member of the Royal Society in the year 1793, and soon became one of the most active and distinguished members of that scientific body. He and Davy became the two secretaries; and Dr. Wollaston contributed no fewer than thirty-nine papers, which were published in succession in the Philosophical Transactions; fourteen of these were upon chemical subjects, ten on subjects connected with optics, the remaining fifteen on miscellaneous subjects.

Dr. Wollaston enjoyed uninterrupted health for many years; but about two years before his death, which happened on the 22d of December, 1823, at the age of sixty-two, he was afflicted with a disease of the brain. After death, it appeared that the portion of the brain from which the optic nerve arises was occupied by a large tumour. In spite of this extensive cerebral disease, Dr. Wollaston's faculties remained unclouded to the last. His powers of vision were exceedingly perfect. I have seen him write on paper and upon glass in so small a hand, that it seemed to be merely a single line drawn across; but when examined by a microscope it assumed the form of regular letters, distinctly visible and easily read. This paper he retained to the last. When he was nearly in his last agonies, one of his friends having observed, loud enough for him to hear, that he was not at that time conscious of what was passing around him, he made a sign for a pencil and paper, which were given him. He wrote down some figures, and after casting up the sum returned them. The account was right.

In the June before his death, he was proposed as a member of the Astronomical Society of London; but according to the rules of that Society he could not have been elected before the last meeting for the year. When the Society met in Nov., 1828, the alarming situation of his health, and the great probability of his dissolution previous to the December meeting, induced the council at once to recommend to the assembled members a departure from the established rule, and that the election should take place at that sitting. This was done, and received the unanimous sanction of the meeting, which insisted on dispensing with even the formality of a ballot. Dr. Wollaston then, within a few days of his death, acknowledged this feeling and courteous act by presenting the Society with a valuable telescope which he greatly prized. It originally belonged to his father, and had been subsequently improved by the application to it of an invention of his own, the triple achromatic object-glass—a device on which astronomers set great value.

At the death of Sir Joseph Banks, Dr. Wollaston was chosen as interim president, from the time of that death, to the 30th November of the same year, which was the usual time for the election of the president. Not a few of the members were anxious that he should have succeeded Sir Joseph Banks as president, but he peremptorily refused to allow himself to be put on the list of candidates. The consequence was, that Sir Humphrey Davy was chosen to fill that important office without opposition.

Towards the latter part of 1828, Dr. Wollaston became dangerously ill of the disease of the brain of which he died. Finding himself unable to write out an account of such of his discoveries and inventions as he was reluctant should perish with him, he spent his numbered hours in dictating to an amanuensis an account of some of the most important of them.

The chief of these is indisputably his method of rendering platinum malleable, which he had practised for many years upon so large a scale, that he is said to have cleared thirty thousand pounds by that process alone. He had ascertained the fact that platinum, like iron, is capable of being welded. Hence he inferred that it might be converted into a metallic rod or plate, susceptible, by skilful hammering, of being converted to vessels of any shape or size required. As it is capable of resisting the greatest heat of our furnaces, and is not acted upon by the reagents employed in chemical experiments and analysis, its immense importance in chemical researches became at once obvious.

But native platinum is a compound or mixture of eight different metals. It was necessary to get rid of these foreign bodies before converting platinum into bars. He dissolved crude platinum in nitro-muriatic acid, filtered and precipitated the platinum by sal-ammoniac. The yellow precipitate was carefully washed, and heated very cautiously in a black-lead crucible, to drive off the sal-ammoniac. The grey residue is platinum. It is rubbed to powder by the hand, and then triturated by a wooden pestle in a wooden mortar, care being taken to do nothing that would polish the edges of the platinum powder, because that would prevent the welding process from taking place. The powder is now put into a brass mould, filled with water, taking care that no vacancies are left. The top of the powder is covered first with paper and then with cloth, and it is then compressed with the force of the hand by a wooden plug. After this, a circular plate of copper is placed on the top, and it is exposed to a very violent pressure in a horizontal press. It is then put into a charcoal fire and heated to redness, to drive off the water.

The ingot of platinum thus formed is placed upon an earthen stand, about 2½ inches above the grate of a wind furnace. The ingot is placed on its end, and is exposed for twenty minutes to the highest temperature that can be raised in the furnace. It is now placed on an anvil, and struck, while hot, on the top with a heavy hammer, so as at one heating effectually to close the metal. It must never be struck on the sides, which would cause it to crack. By this hammering it is brought into the state of a perfect ingot fit for all purposes.

During Dr. Wollaston's experiments on crude platinum, he discovered a new metal, to which he gave the name of *palladium*, or new silver. In the year 1803, he drew up a statement of the most remarkable and characteristic properties of palladium. This statement, together with some specimens of the metal, was exhibited in the windows of some shops in London, without the least hint of who the discoverer was, or from what source the metal was obtained. This very uncommon mode of exhibiting a chemical discovery, naturally led Mr. Chenevix to suspect that the pretended new metal was nothing else than an artificial compound of some metals previously known. He purchased, accordingly, all the specimens of palladium exhibited in London for sale; and after an elaborate and laborious course of experiments, drew up a paper on the subject, in which he showed that it was an amalgam of platinum, or a compound of mercury and platinum. This paper was read at a meeting of the Royal Society, and, unless I am mistaken, Dr. Wollaston himself was the person that read it to the Society.

Chenevix's paper was not only read to the Royal Society, but published in their Transactions for 1803, without any information afforded that the metal called palladium had been discovered and examined by Dr. Wollaston. On taxing Dr. Wollaston with cruel and unhandsome conduct for not intrusting the secret to Mr. Chenevix, he assured me that he had done all in his power to convince Chenevix that he was mistaken—that he had written him, assuring him that he himself had repeated Mr. Chenevix's experiments and found them inaccurate, and that he himself was satisfied, from careful examination, that palladium was a distinct metal. I have no doubt that Wollaston's statement is correct, but think that he ought not have allowed Mr. Chenevix to publish his paper, without betraying the secret of the discovery of palladium, and the reasons which induced him to believe that palladium was a peculiar metal. Chenevix had been occupied at the rate of fourteen hours a day for nearly a quarter of a year. It is not surprising that he was not likely to yield to a set of experiments differing from his own. But the effect of Dr. Wollaston's conduct was to destroy the chemical reputation of Chenevix, and put an end to the chemical career of one of the most active and laborious chemists of his time.

In the Philosophical Transactions for 1804, Dr. Wollaston published an account of the properties of palladium, and pointed out the mistake into which Chenevix had fallen. In the same paper he described the properties of another new metal which he had found in crude platinum, and to which he gave the name of *rhodium*.

It will be worth while to take a short review of Dr. Wollaston's chemical papers, published in the Philosophical Transactions, that we may see the discoveries for which chemistry is indebted to him.

1. The earliest of these discoveries, though the last given to the chemical world, was the method of rendering platinum malleable and ductile. It furnished practical chemists with a most important utensil, to which chemistry is indebted for the great degree of perfection to which chemical analysis of minerals has reached. Everybody now can analyse a mineral with tolerable accuracy; but before Dr. Wollaston supplied a platinum crucible, the analysis of the simplest mineral was a work attended with great labour, and a great waste of time.

All the great improvements in chemistry were preceded by the discovery of certain utensils, which, when applied to chemistry, developed a new series of important facts. The pneumatic apparatus contrived by Cavendish and Priestley, led to the discovery and examination of numerous elastic fluids which had hitherto escaped the attention of chemists. Dr. Wollaston's platinum crucibles speedily brought the art of analysing minerals to a state of perfection. The discovery of the Galvanic battery, and the decomposing power of electricity, led Davy to the discovery of the constitution of the fixed alkalies, alkaline earths, and earths proper, which had previously been considered as simple substances. The simplification and perfection by Liebig of the apparatus contrived by Gay-Lussac and

Thenard for the analysis of vegetable bodies, led immediately to the examination of an immense number of substances of vegetable origin, and the discovery of numerous interesting and important bodies which had hitherto escaped the attention of chemists.

2. It is well known to every individual who takes any interest in chemical investigations, that what is called Dalton's atomic theory was made known to the public about the year 1804. According to that theory, every simple substance is an atom having a determinate weight. Bodies combine either atom to atom, or an atom of one with a certain number of atoms of another. At that time chemists were in possession of hardly any accurate analyses of salts, or of chemical compounds in general. Mr. Dalton founded his theory on the analysis of two gases, namely, protoxide and deutoxide of azote; the first consisting of a certain quantity of azote united with a determined weight of oxygen, the second of the same quantity of azote united to twice as much oxygen. The first of these he considered as a compound of one atom of azote with one atom of oxygen, and the second of one atom of azote united with two atoms of oxygen.

In the year 1808, I supplied Mr. Dalton with two instances of similar combinations, namely:—

- | | |
|-----------------------|--------------------------|
| 1. Oxalate of potash. | 2. Oxalate of strontian. |
| Binoxalate of potash. | Binoxalate of strontian. |

After the perusal of my paper on oxalic acid, Dr. Wollaston read a paper to the Royal Society on *super-acid* and *sub-acid* salts, which was published in the Philosophical Transactions for 1808. In this paper he gives six examples of similar combinations, namely:—

- | | |
|--------------------------|-------------------------|
| 1. Carbonate of potash. | Bisulphate of potash. |
| Bicarbonatate of potash. | 4. Oxalate of potash. |
| 2. Carbonate of soda. | Binoxalate of potash. |
| Bicarbonatate of soda. | Quadroxalate of potash. |
| 3. Sulphate of potash. | |

3. About the beginning of the present century, Mr. Hatchett discovered a new metal in a mineral from America, a specimen of which was in the British Museum. To this new metal he gave the name of *columbium*. Soon after Mr. Hatchett's discovery, a metallic substance was detected in Sweden by Mr. Ekeberg, differing from every other with which he was acquainted. This new metal he distinguished by the name of *tantalum*. The discovery of Hatchett was made known to the public in the Philosophical Transactions for 1802, and that of Ekeberg in the memoirs of the Swedish Academy of Sciences for 1802.

In the year 1809, Dr. Wollaston procured specimens of the Swedish mineral containing *tantalum*, and of the mineral in the British Museum containing *columbium*, extracted a little of the oxide of tantalum from the one, and of the oxide of columbium from the other, and by a very ingenious comparison of the two, demonstrated that both oxides are identical, and that columbium and tantalum constitute one and the same metal. These results were published by Wollaston in 1809, in the Philosophical Transactions, and exhibit a very satisfactory display of his mode of experimenting on a minute scale, and of the sagacity which enabled him to draw the proper conclusions from very simple premises.

4. Dr. Wollaston's discovery regarding *titanium* ought not to be passed over in silence. Titanium is the name given by Klaproth to a new metal discovered by Mr. Gregor in the valley of Menaclan in Cornwall, and called on that account *menachine*. Mr. Gregor published an account of his discovery in 1791. In the year 1795, Klaproth discovered a new metal in a mineral at that time distinguished by the name of red schorl, to which he gave the name of *titanium*. And in 1797 he made a comparative set of experiments on the *menachine* of Gregor and his own *titanium*, by which he established the identity of these two metals with each other. All attempts to reduce the oxide of titanium to the metallic state failed, if we except the small quantity of metallic titanium extracted by Vauquelin and Hecht in 1796, and the subsequent method of reducing the oxide to the metallic state contrived by Liebig in 1831, and deduced by him from Henry Rose's experiments on ammonio-chloride of titanium.

Red cubes having the metallic lustre, are occasionally discovered in the slag of the hearths of the great iron smelting-houses, so abundant in this neighbourhood and in Wales. These cubes were examined by Dr. Wollaston in 1822, and shown to possess the characters of titanium in the metallic state. He found the cubes to consist of metallic titanium of the specific gravity of 5·3, and to be hard enough to scratch rock crystal.

Such was the state of our knowledge of these cubes of metallic titanium, as was supposed, when Wöhler published an elaborate set of experiments on them in the year 1850. He showed that they always contained graphite mechanically mixed. By a very ingenious but complicated set of experiments, Wöhler showed that the metallic cubes of supposed titanium were, in fact, composed of titanium, azote, and carbon, in the proportions—

Titanium,.....	78·00
Azote,.....	18·11
Carbon,.....	3·89

The carbon was combined with azote, constituting cyanogen, while the remainder of the azote was united with the titanium, constituting an azotide. The crystals, according to these experiments, are composed of—

Cyanide of titanium,.....	16·21
Azotide of titanium,.....	83·79

or, 100·00

1 Atom cyanide of titanium.	
3 Atoms azotide of titanium.	

In the year 1823, when Dr. Wollaston's paper was published, the science of chemistry was not far enough advanced to enable him to make a complete and satisfactory analysis of this very remarkable compound.

The next paper of Dr. Wollaston which I shall notice, was inserted in the Philosophical Transactions for 1814, and was entitled a "Synoptical Table of Chemical Equivalents." It had been observed by Richter, that when solutions of two neutral salts which decompose each other are mixed, the new salts formed are always equally neutral. Thus, if 9 parts of sulphate of soda be mixed with 16.25 parts of nitrate of barytes, the two neutral salts will be converted into 10.5 parts of nitrate of soda and 14.5 of sulphate of barytes, the sulphate of barytes will precipitate, and the nitrate of soda will remain in solution. Richter found this law to hold in all the cases tried, and thence inferred that the ratios of saturation of acids and bases were always the same. Thus, 4 by weight of soda will just saturate 5 of sulphuric acid, 6.75 of nitric acid, 7.25 of arsenic acid, 4.5 of phosphoric acid. Dr. Wollaston explained this remarkable property by means of the atomic theory of Dalton. Acids and bases unite atom to atom, or one atom of the one with one or two or more atoms of the other. He showed, by a most laborious investigation, that the same law holds in all chemical combinations. Metals combined with one, two, or more atoms of oxygen to form oxides, with two or more atoms of sulphur to form sulphurets. Every body has a peculiar atomic weight. This he determined in a very considerable number; drew up a table of atomic weights, referred to oxygen as unity, and transferring them to a sliding scale, enabled the practical chemist to see at once the weight of any body necessary to saturate an atom of any other. These scales were exposed to sale, and at one time were very common in laboratories. But the vast number of names upon the scale, made it difficult to discover the name wanted, and on that account they have gradually gone out of use.

6. In the year 1813, a paper by Dr. Wollaston was published in the Philosophical Transactions, giving an account of a very ingenious mode of showing the cold induced in water by evaporation. To the apparatus used, he gave the name of *erygophorus*. It consisted of a glass tube about one-eighth of an inch in diameter, terminating at each extremity in a glass ball about one inch in diameter. This tube was bent at a right angle about half an inch from each ball. One of these balls should contain a little water. This water is boiled till all the air is driven out of the balls and tube. The tube is now hermetically sealed, and allowed to cool. The water is then collected in one ball, while the other at the distance of the tube is plunged into a freezing mixture. By this contrivance the vapour, as it rises from the water, is condensed, and thus the evaporation from the water is continued unabated. The cold generated by this evaporation is so great, that in a few minutes the water in the remote bulb is converted into ice.

7. There is still a paper of Dr. Wollaston's to be noticed. I mean his examination of urinary calculi. It was published in the Philosophical Transactions for 1797, and was indeed the first of his publications. One species of urinary calculi had been examined by Scheele, who showed that it was composed of a peculiar acid substance which exists in urine, on which account it got the name of *uric acid calculus*. Dr. Wollaston analysed four new species of calculus, and determined the composition. These were:—

1. *Fusible calculus*. This calculus before the blow-pipe fused into an opaque white glass. It is a mixture of phosphate of lime, and ammonia-phosphate of magnesia. 2. *Mulberry calculus*. So called by surgeons, because it has a brown uneven surface, having some resemblance to a mulberry. It consists essentially of *oxalate of lime*. 3. *Bone-earth calculus*. It has a brown colour, and a smooth surface. It consists essentially of phosphate of lime, and differs from bone-earth by containing no carbonate of lime. 4. In 1810, Dr. Wollaston discovered a new calculus, to which he gave the name of *cystic oxide calculus*. 5. Gouty concretions, composed of urate of soda.

8. Such is a meagre catalogue of Dr. Wollaston's chemical papers published in the Philosophical Transactions; there is still another notice by him which deserves to be stated.

Dr. Marcet, at the time of his death, was occupied with a set of experiments to determine the quantity of salt in the Mediterranean Sea, and with endeavouring to account for the constant influx of the Atlantic Ocean by the Straits of Gibraltar, without any sensible increase of the specific gravity. He had applied to Captain William Henry Smyth, who was engaged in surveying part of that sea, to supply him with water at great depths from that sea. Dr. Marcet dying before he received the water expected, Captain Smyth gave to Dr. Wollaston three bottles from the bottom of the sea, and at different distances from the Straits of Gibraltar. The first two specimens were taken from 680 miles, and 450 miles from the Straits, at the depths of 450 and 400 fathoms, contained water of the usual specific gravity, namely, 1.0294 and 1.0295. But the third, taken 50 miles from the Straits, and at a depth of 670 fathoms, had a specific gravity of 1.1288. The first two contained 4 per cent. of salt, the last 17.3 per cent. It is clear from this, that an under current outward, if of equal breadth and depth with the current inward at the surface, would carry as much salt below as is brought in above, although it moved with $\frac{1}{4}$ part of velocity, and would thus prevent any increase of salt in the Mediterranean beyond what exists in the Atlantic.

The remaining papers by Wollaston in the Philosophical Transactions amount to twenty-five. They are on various subjects, all ingenious, and each containing a new fact.

Dr. Wollaston's Papers in Philosophical Transactions.

1. On Gouty and Urinary Concretions, vol. 87, p. 386, 1797.
2. On Double Images by Atmospheric Refraction, vol. 87, p. 239, 1800.
3. Experiments on the Chemical Production and Agency of Electricity, vol. 87, p. 427, 1801.
4. A Method of Examining Refractive and Dispersive Power by Prismatic Reflection, p. 365, 1802.

5. On Oblique Refraction of Iceland Crystal, p. 381, 1802.
6. Quantity of Horizontal Refraction, &c., p. 1, 1803.
7. On a New Metal (palladium) in Platina, p. 419, 1804.
8. On the Discovery of Palladium, p. 316, 1805.
9. On the Force of Percussion, p. 13, 1806.
10. On Fairy Rings, p. 133, 1807.
11. On Superacid and Subacid Salts, p. 96, 1808.
12. On Platina and Native Palladium from Brazil, p. 189, 1809.
13. Identity of Columbium and Tantalum, p. 246, 1809.
14. Description of a Reflective Goniometer, p. 253, 1809.
15. On the Duration of Muscular Action, p. 2, 1810.
16. On Cystic Oxide, p. 223, 1810.
17. On the Non-existence of Sugar in the Blood of persons labouring under Diabetes Mellitus, p. 96, 1811.
18. Crystals of Carbonate of Lime, Bitter Spar, and Iron Spar, p. 159, 1812.
19. On a Periscope Camera Obscura, &c., p. 370, 1812.
20. On the Elementary Particles of certain Crystals, p. 51, 1813.
21. Method of Freezing at a Distance, p. 71, 1813.
22. Drawing very fine Wires, p. 114, 1813.
23. Single Lens Micrometer, p. 119, 1813.
24. Synoptic Scale of Chemical Equivalents, p. 1, 1814.
25. On Cutting Diamonds, p. 265, 1816.
26. On Native Iron in Brazil, p. 281, 1816.
27. Cutting Rock Crystal for Micrometers, p. 126, 1820.
28. Sounds Inaudible to certain Ears, p. 306, 1820.
29. Concentric Adjustment of Triple Object-Glass, p. 32, 1822.
30. On the Finite Extent of the Atmosphere, p. 89, 1822.
31. On Metallic Titanium, p. 17, 1823.
32. Magnetism of Metallic Titanium, p. 400, 1823.
33. On the Semi-decussation of the Optic Nerves, p. 222, 1824.
34. Apparent direction of the Eye in a Portrait, p. 247, 1824.
35. Method of making Platinum Malleable, p. 1, 1829.
36. Microscopes Double, p. 9, 1829.
37. Comparing the Light of the Sun and Fixed Stars, p. 29, 1829.
38. Water in the Mediterranean, p. 29, 1829.
39. Differential Barometer, p. 133, 1829.

MONTHLY NOTES.

EXPERIMENTS IN SCREW PROPULSION.—In continuation of our notes on this subject,* we have to record the following experiments:—The *Cádiz*, a new iron steamer of 950 tons and 220 nominal horse power, built by Messrs. Tod and Macgregor, and belonging to the Peninsular and Oriental Company, was fitted with a Griffith's screw, and tried at the measured mile, at Stoke's Bay, on the 16th June. Of ten runs made with the screw, at various pitches, the most successful showed a superiority of a quarter of a knot over the common screw, whilst the vibration was very much lessened. What, however, has most elated the friends of screw propulsion has been the repeated success of the *Bengal*, whose first voyage, considered beyond praise, has been even outstripped by her second. It appears, indeed, as a correspondent of the *Times* remarks, that "the days of paddlebox steamers are numbered," and the most inveterate supporters of the paddle are beginning to change their minds. The Peninsular and Oriental Company are gradually adopting the screw in their large fleet, to the entire exclusion of the paddle. This step was first contemplated when the *Bombay*, *Madras*, *Formosa*, and one or two others, proved successful. The *Bengal* was constructed as a final experiment, and we need not wonder that the triumph she has achieved has brought the company to a decision. What steamers they still have on the principle now beginning to be called "old-fashioned," are, for the most part, to be allowed to wear out; but even such of these as are of a suitable shape, and are worth altering and repairing, are to be changed into screw steamers. The *Haddington*, of 1,600 tons, is, it is said, to be so metamorphosed, being in need of repairs. The *Himalaya*, of 3,500 tons, lately launched, intended to be a paddle-boat when commenced, was subsequently altered to a screw. Amongst those in progress, all screws, are the *Simla*, of 2,600 tons; the *Candia*, 2,200 tons; the *Pera*, 2,200 tons; the *Nabia*, 2,200 tons; and the *Colombo*, 1,900 tons. A comparison of the cost and expenses of the *Bengal*, with those of paddle-steamers of similar class, will give reasons for preference of the former, much more appreciable by the commercial mind than mere scientific considerations. The *Bengal* is of the same size as the *Orinoco*, *Parana*, and *Magdalena*, 2,250 tons, belonging to the Royal Mail Steam-packet Company, and carrying the West India mails. These vessels have engines of 750 horses' power, whilst the *Bengal*, with 470, or about two-thirds of this, has reached a greater speed than any of them. The *Bengal* has a very great advantage with regard to fuel, requiring but 45 tons per day, whilst the three West India boats consume from 85 to 90 tons. A reduction in the amount of fuel, besides diminishing that item of cost, brings with it a gain in the freight; for the *Bengal* could carry 600 to 700 tons of cargo, instead of the mere 250 or 300 tons, which the West India steamers are capable of taking, in addition to their 1,200 tons of coals. The *Bengal* cost, it is said, about £70,000, whilst the *Orinoco* cost from £95,000 to £100,000; and, in addition to all this, is to be considered the difference, in wear and tear, in favour of the screw vessel. With facts like these before them, we cannot be surprised that the attention of men of capital and enterprise is at the present moment so strongly attracted to the new system of propulsion. On the 18th June, Sir Thomas Mitchell's Boom-

* Page 53, Vol. VI., *Practical Mechanic's Journal*.

ering propeller was again tried in the *Conflict*. The instrument employed on a previous trial had been made too weak, and broke almost at starting. On the last occasion no such casualty happened, and a speed of $9\frac{1}{2}$ knots was the average result, of eight runs at the measured mile, in Stoke's Bay. The numbers of revolutions averaged $63\frac{1}{2}$. This speed is said to be somewhat above that obtained in the *Conflict* with a common screw. The diminution of the vibration of the vessel was remarkable. The experiment was, in fact, decided in favour of the new propeller. The trials in Commodore Martin's squadron show that the *Conflict* is far from being a fast vessel, either under steam or canvas; and it is considered that, with vessels of finer lines, proportionately better results will be obtained with the Boomerang. It has continued to be successful in the *Genova*, whose experimental trip we have already recorded, this vessel, on her voyage home from Quebec to Liverpool, having averaged a knot an hour more than she had ever previously done with a common screw. The attention of the public has also lately been called to another and newer system of screw-propulsion, the invention of Mr. Burch, whose beautiful models have been much admired. The invention is an improvement on Griffith's arrangement. The centre of the propeller is occupied by a large drum. The lines of the ship are made to run into the periphery of this drum, and continue beyond it, finally merging into the stern-post, so that the ship is in the shape of a cone at that part. The blades, of course, project outside the drum, and the water is acted on in an unbroken state, as it flows in straight lines along the slip's side, without winding in under the run, or impinging upon a central globe, as in Griffith's plan. The arrangement is, in fact, the carrying out of a suggestion, in reference to Griffith's screw, made in our own columns a few months back.* Mr. Burch has hit upon a very ingenious plan, of reducing the friction between the surfaces of the central drum, and the casing in which it works. A small pipe, communicating with the atmosphere at its upper end, opens, at its lower end, near the centre of the surfaces to be lubricated; and it is expected that the centrifugal action will draw down the air, so as to interpose a film between the surfaces. The quantity must, however, be so regulated, that none shall pass out into the water on which the blades are acting; otherwise, some of their effect will be lost. The size of the central drum allows of the introduction of mechanism for swivelling the blades, and even of drawing them entirely within the drum. The principle possesses several good points, but the proportion of the cones in the models appeared much exaggerated. We understand the models are on their way to the New York Exhibition.—Since these notes were written, a further set of experiments have been made with Griffith's screw. The object was to test the new screw under both steam and canvas, the wind on the previous occasion not having been sufficiently strong to raise the sails. The first trial was made with the angle of the blades set at a coarse pitch, when the engines made $22\frac{1}{2}$ revolutions with the fore and aft sails set. In this manner the *Cadiz* went from Southampton docks to Stoke's Bay—a distance of 14 miles—within the hour, and subsequently ran the measured mile, with a light breeze, as follows:—

	Revolutions.	Steam.	Vacuum.	Time.	Speed.
1st Run, . . .	22 $\frac{1}{2}$	10 $\frac{1}{2}$ lbs.	26 $\frac{1}{2}$	4' 54"	12.245
2d Run, . . .	22 $\frac{1}{2}$	10	26 $\frac{1}{2}$	5' 30"	10.909
	Mean speed, 11.577 knots per hour.				

With the same angle of screw, she made five knots under canvas alone; and afterwards, with the screw feathered, she gave a precisely similar result.

SHAND AND MASON'S SHIP FIRE-ENGINES.—Messrs. Shand and Mason, of the Blackfriars-road, London, have recently introduced a novel form of ship's fire-engine, combining the essentials of simplicity, easy management, and cheapness, with all the efficiency of action for which this firm has long been celebrated. The pump barrels, which are of gun metal, and the air vessel and clacks, are bolted down to a cast-iron sole plate, fixed inside a wooden case, and the two ends of this case are so hinged at the bottom that, when the engine is required for use, these ends may be turned down to lie flat on deck. During working, the sailors place their feet upon the ends so turned down, and thus keep the pump steady. When out of action, the working barrels are unshipped, and placed, with the hose, suction-pipe, and other appurtenances, inside the box, and the ends of the box being closed, the whole forms a compact piece of ship furniture of easy transport.

PREVENTION OF THE DEPOSIT IN STEAM-BOILERS.—Accident, it is said, has revealed to Mr. Ira Hill, an American engineer, a very simple plan of preventing the deposition of lime, on the inner surfaces of steam-boilers. Every engine-man is acquainted with the evils and annoyance arising from the presence of the very refractory sulphate of lime; and it may therefore be interesting for them to know, that one or two shovelfuls of oak sawdust thrown into the boiler, removes the whole difficulty, although the boiler water is strongly impregnated with lime. With such an addition, Mr. Hill has always found his boiler quite smooth and clean as if just oiled. What the theory of action is, whether it is that the depositing lime attaches itself to the floating particles of wood, or whether the tannic acid in the wood has anything to do with the case, in forming with the lime a salt which will not adhere to the iron, is yet to be ascertained. The expedient arose from throwing in some sawdust to stop a leak.

STEAM-SHIP BUILDING UNDER COVER.—We sometime ago engraved and described a building-slip roof, erected at Messrs. T. & W. Smith's, St. Peter's Dock-yard, Newcastle,† as a good example likely to be quickly followed. Since that time the system has been largely adopted, and amongst others, Messrs. Tod & McGregor of Glasgow have resolved to build under cover. The cover or bouse which they have contracted for, is to be a modification of the crystal palace, being covered with glass and gas-lighted. Under this erection several first-class ocean going steamers may be built at once, the men all working full time with every comfort, whatever may be the state of the weather outside. The extent of the building may in some measure be guessed at, when we state that it is to cost £12,000.

FERET'S SPHERICAL WIND-GUARD.—M. Feret of Marseilles has lately proposed to cure the evils attendant upon smoking chimneys, by the use of a simple arrangement of a duplex spherical or ball-shaped cover for the chimney top. Our engraving represents the contrivance, with its outer shell in vertical section.

The part, A, rests on the open end of the chimney, and over this part is a sphere, B, fitted with a loose adjustable lid, C, and having lateral or side apertures for the discharge of the smoke. This inner sphere, B, is covered by an outer case, D, which has an open top and bottom, and rests by its lower edge upon brackets on the outside of the inner sphere, so that there is a complete annular thoroughfare between the two casings. If a side wind strikes the outer case, the sphere deflects the aerial current into two sections, an upper one passing over the top, and a lower one descending the reverse way. This improves the chimney draught, and causes the smoke to pass freely off through the lateral openings in the inner sphere, and thence out of the outer case either above or below. In the same way a "blow-down" is deflected by the spherical contour of the case, whilst the smoke gets away at the annular passage beneath.

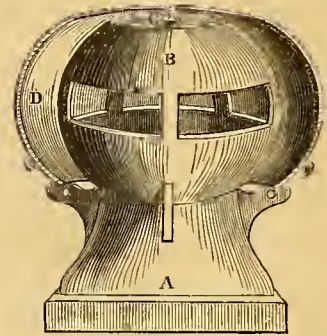

PROVISIONAL PROTECTIONS FOR INVENTIONS UNDER THE PATENT LAW AMENDMENT ACT.

☞ When the city or town is not mentioned, London is to be understood.

Recorded March 14.

635. John O'Leary, Liverpool—Improvements in chests for the use of emigrants, whereby they are also made applicable to other purposes.
637. John H. Johnson, 47 Lincoln's-inn-fields, and Glasgow—Improvements in the application of porcelain and similar materials to ornamenting purposes.—(Communication.)

Recorded April 14.

905. Thomas Haigh, Halifax—Invention for the cleansing of pans and other culinary utensils.
906. John W. Duncan, Grove-end-road, St. John's Wood—Certain new combinations of gutta percha with other materials, and the method of applying such for use.

Recorded April 19.

940. William Hale, Chelsea—Invention of a new kind of fire-arms.
943. Frederick H. Smith, Southwark—Improvements in apparatus for cleansing the interior of tubular boilers and other hollow articles.
947. Edward Vivian, Torquay—Improvements in cases for containing hats in churches and similar situations.

Recorded April 21.

959. Thomas Dann, Pendleton, near Manchester—Certain improvements in and applicable to boilers or apparatus for generating steam, and in apparatus connected therewith.

Recorded April 23.

977. Frederick Tompkins, Manchester—Improvements in the mode or method of embossing and finishing woven fabrics, and in the machinery or apparatus employed therein.
981. Henry Houldsworth, Manchester—Improvements in machinery used for combing cotton, silk, silk waste, flax, tow, wool, and other fibrous substances.

Recorded April 27.

1011. James Dinning, Southampton—Certain improvements in wash-stands and baths, part of which improvements are also applicable to table fountains.
1027. Alfred G. Anderson and John B. Anderson, Great Suffolk-street, Southwark—Improvements in the treatment of certain saponaceous compounds obtained in the manufacture of soap.

Recorded April 28.

1029. John Hetherington, Manchester—Certain improvements in machinery for combing cotton, wool, silk waste, flax, tow, and other fibrous substances.
1032. Peter Fairbairn, Leeds—Improvements in machinery for drawing, roving, and spinning flax, hemp, and other fibrous substances.

Recorded May 2.

1056. James Greenwood, New Acerrington—An improvement in fixing mordants on fabrics.

Recorded May 3.

1072. George T. Holmes, Norwich—Improvements in thrashing machines and apparatus connected therewith for shaking the straw, riddling, winnowing, and dressing the corn.
1073. Robert W. Swinburne, South Shields—Improvements in the manufacture of glass.
1074. George F. Goble, Fish-street-hill—Improvements in locks.
1075. Richard Quin, Pentonville—Improvements in the manufacture of cases for jewellery, or optical and other instruments, miniatures, and other articles.

1076. Severin V. Bonnetier, Paris—Certain improvements in machinery for manufacturing screws.

1077. Edward T. Bainbridge, St. Paul's Churchyard—Improvements in obtaining motive power.

1078. Louis Cornides, Charing-cross—Improvements in treating certain ores and minerals for the purpose of obtaining products therefrom.

1079. Thomas Chambers and John Chambers, Thorncroft, near Sheffield—Certain improvements in kitchen sinks.

1080. Frederick Arnold, Barnsbury—Certain improvements in hinding or covering hooks.

1081. William E. Newton, 66 Chancery-lane—Improvements in hot-air furnaces for heating buildings, some of which improvements are applicable to other furnaces.—(Communication.)

1082. Frederic Lipscombe, Strand—Improvements in propelling vessels.

1083. William E. Newton, 66 Chancery-lane—Improved machinery or apparatus for dressing millstones.—(Communication.)

* Page 261, Vol. V.

† See Page 130, Vol. IV., *Practical Mechanic's Journal*.

Recorded May 4.

1084. George Bell, Inchmichael, Perth—Invention of a new machine for several agricultural purposes.
1085. Edward Walmsley, Heaton Norris—Improved modes of preventing accidents arising from an insufficient supply of water in steam boilers.
1086. Cornelius A. Jaquin, 40 Monkwell-street—Improvements in the manufacture of covered buttons made by dies and pressure.
1087. Charles Videgrain, Paris, and 16 Castle-street, Holborn—Certain improvements in the treatment and preparation of certain natural or artificial stones, to render them applicable to various useful and ornamental purposes.
1088. Jean B. Giannetti, Paris, and 16 Castle-street, Holborn—Invention of applying the ascensional force of balloons to various useful purposes.
1089. Thomas Masters, Oxford-street—Improvements in apparatus for freezing, cooling, and churning.
1090. John H. Hutchinson, Grantham—Improvements in ventilating bricks.
1091. Edmund J. Oekenden, the elder, and Edmund J. Oekenden, the younger, Brighton—Improvements in valves and stop-cocks.
1092. James E. Cooke, Greenock—An improved composition for coating and preventing the decay of exposed surfaces.
1093. Jean B. Verdun and Jean B. Mertens, Paris—Certain improvements in the construction of celestial and terrestrial globes.
1094. John S. Russell, Great George-street, Westminster—Improvements in marine steam engines.
1095. Charles Goodyear, 25 Avenue-road, St. John's Wood—Improvements in combining India rubber with certain metals.
1096. Thomas Taylor, Manchester—Improvements in apparatus for measuring and for governing the flow of water and other liquids.
1097. William E. Newton, 66 Chancery-lane—Improvements in apparatus for rolling iron.—(Communication.)
1098. William E. Newton, 66 Chancery-lane—Improvements in the treatment of fibrous and other substances, for the purpose of ascertaining the quantity of moisture contained therein.—(Communication from M. Joseph L. Rogeat, Lyons.)
1099. James Walker, Bow—Improvements in turn tables used for railway and other purposes.

Recorded May 5.

1100. William Moore, Duke-street, Lambeth—Improvements in furnaces.
1101. Joseph D. Holdforth, Leeds—Improvements in machinery for combing or dressing silk and other fibrous substances.
1102. John Iawe, jun., Lemaile, near Wadebridge—Invention for propelling vessels and other vehicles in the water.
1103. Joel Livesey, Bury—An improvement in looms for weaving.
1104. Jean C. Stiffel, 31 Poultry—Improvements in machinery for crushing auriferous quartz, and amalgamating the gold therefrom.—(Communication from H. Berdan, New-York.)
- 1105.—Matthias E. Boura, Crayford—Improvements in saddlery and harness.
1107. John Whittier, Stapleford—Improvements in warp machinery for producing ornamented and textile fabrics.
1108. John Hetherington, Manchester—Improvements in preparing cotton, wool, flax, silk, and other fibrous substances for spinning.
1109. Thomas S. Prideaux, St. John's Wood—Improvements in propelling vessels.
1110. Thomas Fearnley, Bradford—Improvements in steam boilers.

Recorded May 6.

1112. Charles W. Bell, Manchester—Improvements in carriage springs.
1113. Thomas Murray, Marygold, Berwickshire—Invention of a new machine or implement for hoeing, cutting, and otherwise operating upon turnips, or other agricultural produce.
1114. George Dowler, Birmingham—Improvements in boxes for containing and igniting matches.
1115. Augustus Braekenbury, Camden Town.—Improvements in precipitating the muriate of soda from its solutions in water.
1116. John R. Danks and Bernard P. Walker, Wolverhampton—Improvements in machinery or apparatus for the manufacture of nails.
1117. James E. A. Gwynne, Essex Wharf, Essex-street, Strand—Improvements in the treatment or manufacture of peat and other substances to be used as fuel.
1118. John T. Stroud, Birmingham—Improvements in the valves of pressure lamps, and in lamp burners.
1119. George W. Jacob, Dalston—An improved manufacture of metallic covers or seals for bottles, jars, and other like vessels, and in applying or affixing them.
1120. Peter Armand Le Comte de Fontaine Moreau, Paris, and 4 South-street, Finsbury—Certain improvements in the manufacture of hat plush.—(Communication.)
1121. Christopher Nickels, York-road, Lambeth—Improvements in machinery for masticating, kneading, or grinding india-rubber, gutta percha, and other matters.
1122. William Longmaid and John Longmaid, Beaumont-square—Improvements in treating waste products obtained in smelting, and otherwise treating ores and minerals, and in producing a valuable product or products therefrom.
1123. Mariano Riera, 29 Boulevard St. Martin, Paris—Certain improvements in fire-arms.
1124. Francesco Capecioni, 16 Castle-street, Holborn—Certain improvements in the manufacture of candles.

Recorded May 7.

1125. James Nichol, Edinburgh—Improvements in bookbinding.
1126. Christopher R. N. Palmer, Amwell—A new and improved mode of communicating or signaling between the guards and engine drivers on a railway train, also applicable to other purposes.
1127. John Pullman, 17 Greek-street, Soho—Improvements in the manufacture of losh, or oil-dressed leather.
1128. Henry Warner, Joseph Haywood, and William Cross, Loughborough—Improvements in machinery used in the manufacture of frame-work knitting.
1129. Hesketh Hughes, Cottage-place, City-road—Improvements in machinery for weaving.
1130. William Boggett, St. Martin's-lane, and George B. Petit, Lisle-street—Improvements in apparatus for heating by gas.
1132. Alexander Chaplin, Glasgow—Improvements in the construction of ships and boats.
1133. George England, New Cross, Surrey—Improvements in screw jacks.

Recorded May 9.

1134. Edward B. Beaumont, Bamsley, York—Certain improvements in the mode of constructing dwelling-houses or other buildings, and in peculiar shaped bricks and tiles to be used for the purpose.
1135. John Fisher, Liverpool—Improvements in machinery for propelling vessels, and in the mode of manufacturing the same.
1136. David Law and John Inglis, Glasgow—Improvements in moulding or shaping metals.
1137. John H. Johnson, 47 Lincoln's-inn-fields, and Glasgow—Improvements in machinery for combing and preparing wool, and other fibrous materials.—(Communication.)
1138. John H. Johnson, 47 Lincoln's-inn-fields, and Glasgow—Improvements in coating or plating vessels, and other articles, for the better resistance of the action of acids and salts.—(Communication.)

1139. Peter Wright, Dudley—Improvements in the construction or manufacture of tweed-irons.
1140. Thomas Quaife, Battle—Improvements in the manufacture of watches, watch-cases, and in tools and apparatus employed therein.

Recorded May 10.

1142. James Brown, 2 Bridge-terrace, Canal-road—An improvement in anchors.
1143. John Clapham, Thomas Clapham, and William Clapham, Keighley—Improvements in moulding and casting iron pipes.
1144. Thomas Murray, Marygold, Berwick—Certain improvements in breaks or drags for wheeled carriages, and in adapting the carriages for the application and use of such breaks.
1145. Gregory Kane, Dublin—Invention of the construction of portable houses or portions thereof, out of parts, which may be used for other purposes.
1146. Octavius H. Smith, Bedford-square, and Youngs Parfrey, Pimlico—Improvements in the manufacture of carriage wheels.
1147. Robert Brown, 58 Waterloo-road, Liverpool—Improvements in lifting and forcing water and other fluids.
1148. George Tillett, Kentish Town—Improvements in the manufacture of metal bedsteads.
1149. George Robertson and Alexander Robertson, Bradford—Improvements in apparatus for drying and finishing woven fabrics.
1150. William Johnson, 47 Lincoln-inn-fields, and Glasgow—Improvements in machinery or apparatus for sewing.—(Communication from William Wickersham, Lowell, U.S.)
1152. Alexander Chaplin, Glasgow—Improvements in apparatus for the transmission of aeriform bodies.
1153. George S. Buchanan, Glasgow—Improvements in the treatment or finishing of textile fabrics.

Recorded May 11.

1154. Samuel Russell, Sheffield—Improvements in handles for razors.
1155. Jacob Brett, Hanover-square—Improvements in electric telegraph apparatus.—(Partly a communication.)
1156. Marie P. F. Mazier, Aigle, France—Invention of a machine for cutting and reaping corn, corn crops, and other plants.
1157. Samuel C. Lister, Manningham, Yorkshire—Improvements in treating and preparing, before being spun, wool, cotton, and other fibrous materials.
1158. John Crabtree and Livesey Scott, Heywood—Certain improvements in machinery
1159. Henry P. Burt, 2 Charlotte-row—Improvements in portable houses, for preparing and spinning cotton and other fibrous substances.
1160. Richard Edmondson, Blackburn—Certain improvements in the manufacture of covered corded textile fabrics, and in machinery to be used for that purpose, being applicable either to hand or power.
1161. John Mottram, Liverpool—Improvements in machinery for washing ores, and separating metals from earth or other compounds.
1162. Thomas P. Jordonson, Lewisham-road, New Cross, Kent—Certain improvements in rafting timber and other goods.
1163. John Bottonley, Bradford—Improvements in the manufacture of textile fabrics.
1164. William Bradbury and Frederick M. Evans, Whitefriars—Improvements in taking impressions and producing printing surfaces.—(Communication.)
1165. Alfred Bird, Birmingham—Improvements in the means of communicating between guards or persons and the engine-driver of a railway train.
1166. Julien F. Belleville, Paris—Improvements in propelling.
1167. Edmund Whitaker, Rochdale, and James Walmsley, the younger, Smithy Bridge, near Rochdale—Improvements in the manufacture of pipes, tiles, bricks, and slabs from clay.
1168. John L. Stevens, 63 King William-street—An improved fastener for flowers and shrubs.
1169. George Bell, Powell-street—Improvements in obtaining liquid cement and pigments or paints.
1170. Abraham Matthews, Denby-street, Pimlico—Improvements in disengaging boats from ships or other vessels.
1171. William Bull, Battersea—Improvements in direct acting steam engines with fixed cylinders.

Recorded May 12.

1172. George F. Goble, 15 Fish-street-hill—Improvements in propelling vessels and carriages, parts of the machinery therein employed being also applicable to other like purposes.
1173. James Parkes, Birmingham—Invention of a new or improved stop-cock for regulating the flow of gases.
1174. Martin W. O'Byrne and John Dowling, 2 Raquet-court, Fleet-street—Improvements in the manufacture of mangles.
1175. Joseph Denton, Prestwich—Improvements in machinery or apparatus for manufacturing looped terry, or other similar fabrics.
1176. Joseph Sawte I, Newport—Improvements in economizing fuel, by rendering available the heat from coke ovens, and applying the same to the heating of air-kilns, stoves, ovens, and to the generation of steam.
1177. Julian Bernard, Guildford-street, Russell-square, and Edward T. Bellhouse, Manchester—Improvements in pressing and in extracting fluids.

Recorded May 13.

1178. Charles Pooley, Manchester—An improved mode of feeding machines for opening, cleaning, blowing, and scutching cottons, and other fibrous substances.
1179. Joseph S. Eidnaus, Lacey-terrace, Kennington-road—Certain improvements in umbrellas and parasols.
1180. John Arrowsmith, Bilston, Staffordshire—Invention of a new or improved turntable.
1181. George Bertram, Edinburgh—Improvements in the manufacture of paper.
1182. George Stiff, Minerva cottage, Brixton-hill—An improved construction of printing machine.
1183. William Thomas, Cheapside—Improvements in weaving narrow fabrics for hinding.
1184. Charles Tetley, late of Bradford, but now of Skinner-street—Improvements in rotary engines.
1185. Robert S. Bartlett, Redditch—Improvements in sewing machines.
1186. Richard A. Brooman, 166 Fleet-street—Improvements in the manufacture of hats.—(Communication.)
1187. Edward T. Bellhouse, Manchester—Improvements in steam boilers.
1188. John Knowles, Manchester, and Edward T. Bellhouse, saue place—Certain improvements in the manufacture of articles of marble.

Recorded May 14.

1189. Richard Eades, Birmingham—Invention of a new or improved metallic wheel.
1190. George F. Russell, 9 Duke-street, Adelphi—Invention of an apparatus for disengaging, lowering, and raising ships' boats.
1191. George Coppock, Heaton Norris—Certain improvements in looms for weaving.
1192. John Browne, Upper Charlotte-street—Improvements in the construction of chimneys or flues, and in apparatus for increasing draught, consuming smoke, or utilizing the same.
1193. James Higgin, Manchester—Improvements in printing or dyeing woven or textile

- fabrics, and in the manufacturing of certain substances to be used in the arts or processes of dyeing and printing.
1194. Thomas S. Holt, Manchester—Improvements in steam-engines, which improvements are also applicable to the machinery or apparatus connected to steam-boilers.
1195. Moses Poole, Avenue-road, Regent's-park—Invention of a new or improved machine for pegging boots or shoes.—(Communication from Edward L. Norfolk, U.S.)
1196. Herman D. Mertens, Margate—Improvements in preparing materials to be employed in making beer and other beverages.—(Communication.)
1197. William J. Warner, King-street, Soho—Improvements in dry gas-meters.
1198. Francis M. Jennings, Cork—Improvements in treating wool, silk, feathers, and other animal matters, for softening and otherwise improving the quality of the same.
1199. John O'Keefe, Liverpool—Improvements in the manufacture of watch cases.
1200. Stephen Garrett, 16 Taunton-place, Bermondsey—Improvements in the preparing and tanning of skins, hides, or pelts of animals.
1201. Peter Armand Le Comte de Fontaine Moreau, 4 South-street, Finsbury—Certain improvements in steam-boilers.—(Communication.)
1202. John D. Brady, Cambridge-terrace—Improvements in knapsacks.
1203. Robert W. Swinburne, South Shields—Improvements in apparatus or machinery to be used in the manufacture of glass.
1204. Eugene Rolt, St. John's Wood—Certain improvements in pianofortes.
1205. Eugene Rolt, St. John's Wood—Certain improvements in pianofortes.
- Recorded May 16.*
1206. Jean J. J. Jamin, Gerard-street, and Alexander Symons, Strand—Certain improvements in the manufacture of boots and shoes.
1207. Jean E. Barse, Paris—Improvements in the manufacture of grease or composition for lubricating the axles and moving parts of machinery.
1208. Thomas Richardson, Newcastle-upon-Tyne—Improvements in the manufacture of certain compounds containing phosphoric acid.
1209. Robert Boyd, Paisley—Improvements in weaving.
1210. William L. Tizard, Aldgate High-street—Improvements in dredging machines.
1211. Moreton H. Phillips, Shrewsbury—An improved gun.
1212. George Jones, Birmingham—Improvements in ventilating mines.
- Recorded May 17.*
1213. Charles J. Pownall, Addison-road—Improvements in the preparation and treatment of flax and other similar vegetable fibres.
1214. John L. Stevens, 63 King William-street—Improvements in grates and stoves.
1215. Joseph Webb, Mayfield-terrace, Dalston—Improvements in rotatory engines.
1216. James T. G. Vizetelly, Peterborough-court, and Henry Richard Vizetelly, Gough-square—Improvements in printing machines.—(Communication.)
1217. Samuel Eccles and James Eccles, Kensington, Philadelphia—Certain improvements in power-looms for weaving figured fabrics.
- Recorded May 18.*
1218. Charles Cowper, 20 Southampton-buildings, Chancery-lane—Improvements in machinery for combing and preparing wool and other fibrous substances.—(Communication.)
1219. Christopher R. N. Palmer, Amwell, Hertford—An improved mode and apparatus for working the machinery in factories and ships, in connexion with the steam engines or steam power now used therein.
1220. John Haskett, 52 Wigmore-street—Improvements in anchors, to be called the "Ferdinand Martin Safety Anchor."—(Communication.)
1221. Bernard P. Walker, Wolverhampton, and James Warren, Mile End-road—Improvements in the manufacture of iron.
1222. Wharton Rye, Collyhurst, near Manchester—Certain improvements in kitchen ranges or fire-grates.
1223. Charles Clarkson, 9 Avery-row, Lower Grosvenor-street—An improved duster or dusting brush, painting brush, and all other description of brushes, the handle of which passes through the centre, and the hair or bristles are bound or tied round it.
1224. Richard Thompson, 3 Finsbury-chambers, Bloomfield-street—Invention for making perforated building-stone.
1225. John Ryan, Liverpool-street—Invention of an apparatus for purifying liquids in a ready and economical manner.
1226. John Barsbam, Kingston-upon-Thames—Improvements in drying bricks, peat, and other articles.
1227. John Barsbam, Kingston-upon-Thames—Improvements in charring peat and other vegetable substances, and in burning lime.
1228. Edward T. Simpson, Wakefield—Improvements in the manufacture of manure.
1229. George Sant, Norton Lodge, Mumbles, Swansea—Improvements in clocks or time-keepers.
1230. William Gossage, Widnes, Lancashire—Improvements in the manufacture of alkali from common salt.
1231. John Oakey, Blackfriars-road—Improvements in reducing emery, glass, and other like substances.
1232. Benjamin Newton, Brighton—Improvements in the manufacture of mats.
1233. Job Allen, Bower-street—Improvements in communicating intelligence.
1234. Edward Briggs, Castleton Mills, near Rochdale—Improvements in the manufacture of pile fabrics, and in the machinery or apparatus employed therein.
- Recorded May 19.*
1235. Samuel Wright, 24 Church-street, Soreditch—Invention for making a gas, steam, air, or liquid safety-tap.
1236. Thomas Grahame, Wellingborough, Northampton—Improvements in the manufacture of covering materials for houses and other structures and surfaces.
1237. William E. Newton, 66 Chancery-lane—Improved machinery or apparatus applicable for pumping water, and supplying steam boilers with water, and maintaining the water therein at a proper level.—(Communication.)
1238. John Hipsley, Stoneaston, Somersetshire—Improvements in steam-engines suitable for agricultural purposes, and to locomotion on common roads.
1239. John A. Gilbert, Clerkenwell—An improvement in canisters.
1240. Joseph Wainwright, Heap, near Bury—Certain improvements in apparatus for regulating or governing the speed of steam-engines.
1241. John T. Manifold, Charles S. Lowndes, and John Jordan, Liverpool—Improvements in the method of extracting the juice from the sugar cane.
1242. William Fulton, Paisley—Improvements in the treatment and scouring or cleansing of textile fabrics.
1243. Charles De Bergue, Dowgate-hill—Improvements in the permanent way of railways, and also in chairs, and in sleepers for permanent way.
- Recorded May 20.*
1244. St. Thomas Baker, King's-road, Chelsea—Improvements in revolving shutters.
1245. Charles Cowper, Kensington—Improvements in steam boilers.
1246. Edward J. Schollick, Aldingbam Hall, Ulverstone—Improvements in obtaining motive power.
1247. Samuel Schollick, Ulverstone—Improvements in ship-building.
1248. Henry Gilbert, Kensington—Improvements in apparatus for cleaning boots and shoes.
1249. Auguste E. L. Bellford, 16 Castle-street, Holborn—Improvements in rotary engines to be driven by steam or any vapour, fluid, or gas, and in boilers or generators to be used in generating steam or gas for driving the aforesaid or other engines, or for other purposes.—(Communication.)
1250. Thomas L. Dunsdale, Kingston, near Dublin—Improvements in purifying coal gas and in disinfecting sewage or other fetid matters, and in absorbing noxious gaseous exhalations.
1251. Edward H. Bentall, Heybridge—Improved machinery or apparatus for measuring and indicating the power exerted by engines, and also the force required to propel machinery, carriages, or ploughs.
1252. William C. Thornton, Cleckheaton—Improved machinery for making wire cards.
- Recorded May 21.*
1253. George Carter, Mottingham, Kent—Improvements in the manufacture of fire-lighters, and in machinery connected therewith.
1254. John Blair, Manchester—An invention for the application of steam power to the working of railway breaks.
1255. Joseph Betteley, Liverpool—Improvements in anchors.
1256. Louis G. D. B. Ducayla, Bordeaux, France—An improved manufacture of artificial fuel.—(Communication.)
1257. George Marriott, Hull—Improvements in the manufacture of fire-lighters.
1258. Auguste E. L. Bellford, 16 Castle-street, Holborn—Improvements in navigable vessels to be employed in all waters, and to be propelled or impelled by sails, steam power, or other means.—(Communication.)
- Recorded May 23.*
1259. Samuel A. Carpenter, Birmingham—Invention of a new or improved elastic webbing or fabric.
1260. Evan Evans, Birmingham—An improvement or improvements in castors for furniture.
1261. Adolphe A. Girouard, Paris, and 16 Castle-street, Holborn—Certain improvements in paving and generally in covering surfaces with asphaltic and other similar materials.
1262. William Simson, Edinburgh—Improvements in locks.
1263. Auguste E. L. Bellford, 16 Castle-street, Holborn—An improved method of treating flax and hemp, whereby they are brought to such a state that they may be carded, spun, and woven by machinery, such as is now employed in the manufacture of cotton and wool into yarn and cloth.—(Communication.)
1264. Amédée Devy, 73 Grosvenor-street, Grosvenor-square—Improvements in storing and preserving grain.—(Communication.)
1265. John H. Browne, Arthur's Seat, Aberdeen—Improvements in apparatus for bottling or supplying vessels with fluids.
1266. Paul Hanuic and Gustave Collason, 43 Rue de la Victoire, Paris—Improvements in the treatment of oil.
1267. Henry Turner, 19 Wilson-street, Limehouse—Invention of a new mode of applying hydraulic power to windlasses, for weighing anchors and lifting heavy weights.
1268. John H. Johnson, 47 Lincoln's-inn-fields, and Glasgow—An improved forge hammer.—(Communication from Jean Schermer.)
1269. John H. Johnson, 47 Lincoln's-inn-fields, and Glasgow—Improvements in the construction of pipe and other junctions.—(Communication from Laforest and Bondeville, Reims, France.)
1270. William J. Sluce, Bethnal-green-road, George B. Mather, Derby, and Philip Wood, Stratford—Invention of a new apparatus for raising and forcing water or other fluids.
- Recorded May 25.*
1271. William Babb, Gray's-inn-road—Improvements in the manufacture of hair trimmings.
1272. William Babb, Gray's-inn-road—Improvements in the manufacture of hats, caps, and bonnets.
1273. William Church, Birmingham—Invention of a new or improved sight for cannons or other ordnance.
1274. George L. Higginson, Meeting-house-lane, Dublin—Improvements in machinery or apparatus for evaporating or concentrating liquids.
1275. Frederick Russell, Clarence-gardens, Regent's Park—Improvements in raising and lowering windows, shutters, blinds, and similar appendages.
1276. James Lovell, Glasgow—Improvements in heating and ventilating.
1277. Louis A. Deverté, Argenteuil, near Paris, and 16 Castle-street, Holborn—An improved machinery for combing wool.
1278. Samuel S. Hall, Circus, Minorities—Improvements in the means of preventing railway carriages running off the rails.—(Communication.)
1279. Pierre T. Baudcrovet, Ghent, Belgium—Improvements in shutters.—(Communication.)
1280. William E. Newton, 66 Chancery-lane—Improvement in the generation of steam.—(Communication.)
1281. Jonathau D. Carr and John Carr, Carlisle—An improved construction of oven.
- Recorded May 26.*
1282. Alexander Porecky, Bishopsgate-street Within—Improvements in the manufacture of umbrellas and parasols.
1283. Thomas Singleton, Over Darwen, Lancashire—Improvements in looms.
1284. George Simpson, Manchester—Improvements in weighing machines.
1285. William Raster, M.A., Woolwich—Invention of central action-buffers and spring-guides for traversing-rods.
1286. Charles Cowper, 20 Southampton buildings, Chancery-lane—Improvements in the manufacture of iron.—(Communication.)
1287. William Warcup, Lyndhurst Villa, Coronation-road, Bristol—Improvements in the construction of springs for carriages, and similar purposes.
1288. Alphonse R. le M. de Normandy, Judd-street—Improvements in regulating the pressure of steam.
1289. Jonathau Saunders, St. John's Wood—Improvements in the manufacture of railway and other wheel tyres.
1290. Theophilus Westhorp, West India-road, Poplar—Improvements in the manufacture of oakum.
1291. William J. Harvey, 68 South-street, Exeter—Improvements in fire-arms.
1292. John Box, 27 Rue Pepinière, Brussels—Improvements in supplying water to steam-engine boilers.—(Partly a communication.)
1293. William Weatherley and William Jordan, Chatham—Improvements in the stuffing-boxes of piston-rods.
1294. Julius A. Roth, Philadelphia—Improvements in the mode of, and machinery for, treating the fibres of flax, hemp, China grass, and other analogous substances preparatory to spinning.—(Partly a communication.)
- Recorded May 27.*
1295. William Henham, East Peckham—Certain improvements in ploughs.
1296. Samuel S. Shipley, 3 Fowkes-buildings, Tower-street—Improvements in cases or receptacles for containing a composition shaving soap or other articles.
1297. Claude Arnoux, Paris, and 4 South-street, Finsbury—Certain improvements in the construction of locomotives.
1298. Aristide M. Servau, Philpot-lane—Improvements in treating fatty matters to render them suitable for the manufacture of candles.
1299. John L. Stevens, 62 King William street—Improvements in furnaces.

1308. Alexander Keiller, Dundee—An improved machine for the manufacture of confections, including all kinds of comfits known by the trade as pan goods.
1310. William H. Bentley, Bedford—Improvements in locks and keys, parts of which are applicable to window sashes and doors.

Recorded May 23.

1311. Illingworth Butterfield, Bradford—Improvements in and applicable to looms for weaving.
1312. William Smith, 10 Salisbury-street, Adelphi—Certain improvements in the machinery for and method of making and laying down submarine and other telegraph cables, which machinery is also applicable and is claimed for the making of ropes and cables generally.
1315. Richard A. Brooman, 166 Fleet-street—Improvements in abdominal supporters.—(Communication.)
1316. Caleb Hill, Cheddar, Somerset—Improvements in the construction of stays.
1317. Francois Francillon, Puteaux, France—Improvements in dyeing and printing silk, wool, and other animal fibres.
1318. Daniel Bateman, Low Moor, near Bradford—Improvements in carding wool and other fibrous substances, and in the manufacture of cards for that purpose.
1319. Christopher Binka, Albert Villa, North Woolwich, Kent—Improvements in manufacturing chlorine, and in obtaining certain salts and other useful products from the residual matters of lusk manufacture.
1320. William W. Marston, New York—Improvements in breech-loading fire-arms, and in cartridges for use with such arms.
1323. Alfred W. Sanderson, Cable-street, Lancaster—Improvements in preparing effervescent powders.

Recorded May 30.

1327. John Macdonald, 13 Henry-street, Upper Kennington-lane, Vauxhall—Improvements in and applicable to lamps, also applicable to apparatus for lighthouse signal purposes, part of the invention applicable for other useful purposes.
1328. Francis W. Wymer, Newcastle-on-Tyne—Improvements in raising and lowering ships' boats, and in the apparatus connected therewith.
1329. Julian Bernard, Guildford-street, Russell-square—Improvements in obtaining differential mechanical movements.
1331. John C. Bothams, Vine Cottage, Londonderry-road, Surrey—Improvements in condensing steam engines.
1332. Richard A. Brooman, Fleet-street—Improvements in fire-arms.—(Communication.)
1333. John G. Appoll, Wilson-street, Finsbury-square—Invention of a new construction of screw propeller.

Recorded May 31.

1334. William Brookes, 73 Chancery-lane—Improvements in stoves and grates, or fire-places.—(Communication.)
1335. William F. Shoehridge, Thanet-cottage, East Greenwich, Kent—Improvements in the manufacture of drain pipes.
1336. George Goodlet, Leith—Improvements in engines to be worked by steam, air, or air and water combined.
1338. William E. Newton, 65 Chancery-lane—An improved construction of hand stamp.—(Communication.)

Recorded June 1.

1339. Joseph Morris, Astwood Bank, near Redditch, Worcester—An improvement or improvements in the manufacture of envelopes for needles.
1340. Edward Wilkins, 60 Queen's-road, Walworth—Improvements in pots and vessels for the growth and cultivation of plants.
1341. Alfred Hardwick, Chatham-street, Liverpool—Improvements in propelling vessels.
1342. Thomas Aitken, Bury, Lancashire—Improvements in furnaces for steam boilers and other purposes.
1344. Jaques L. Lemaire-Daimé, Paris, and 16 Castle-street, Holborn—Certain improvements in play arms, such as play cannons, pistols, and guns.
1345. Maxwell Scott, Birkenhead, Chester—Improvements in propelling.
1346. James Stocks, jun, Ovenden, Halifax, York—Improvements in looms for weaving.

Recorded June 2.

1343. William Knowles, Bolton-le-Moors, Lancashire—Improvements in machinery for warping and beaming yarns or threads.
1349. Joseph Whitworth, Manchester—Improvements in machinery for cutting and harvesting corn, grass, and other crops.
1350. Joseph Whitworth, Manchester—Improvements in machinery for perforating or punching paper, card, and other materials.
1351. John R. Johnson, Stanhook-cottage, Hammersmith—Improvements in the manufacture of type and articles used in letter-press printing.
1352. William Thorold, Norwich—Improvements in the construction of portable houses, and in machinery for raising, moving, and lowering the same.
1353. Richard L. Hattersley, Keighley, York—Improvements in machinery for forging iron and other metals.
1354. William H. Smith, Gloucester-row, Walworth—Improvements in the manufacture of parchment.
1355. Antoine R. C. Madoré and Daniel Nenberger, Paris, and 16 Castle-street, Holborn—Certain improvements in the manufacture of shirts.
1356. Hesketh Hughes and William T. Denham, City-road—Improvements in machinery for weaving.
1357. Robert S. Barleat, Redditch, Worcester—Improvements in the manufacture of needles.
1358. Nicholas M. Cummins, Cork, and John De Cock Kenifick, Belfast—Improved machinery for removing the seed from flax and other plants, and breaking the bolls or pods.
1359. William Boyd, Belfast—Improved apparatus for manufacturing chlorine or chlorides.
1360. William E. Newton, 65 Chancery-lane—Improvements in the manufacture of soles for boots, shoes, and other coverings for the feet.—(Communication.)

Recorded June 3.

1361. William Wahler, 22 Myddleton-street, Clerkenwell—Invention for lithographic printing, being a self-acting lithographic printing machine, to be propelled by hand, steam, or other motive power.
1362. Jean Durandean, jun., Paris, and Castle-street, Holborn—Certain means of obtaining marks and designs in paper.
1363. Ferdinand L. Gossart, Paris, and 16 Castle-street, Holborn—Invention of a system of permanent circulation of caloric, intended to produce and overbeat steam, gas, and liquid.
1365. James S. Wilson, Tavistock-place, Russell-square—Invention of a machine or apparatus for digging or raising earth, and applicable to agricultural or engineering purposes.
1366. Isaiah Kendrick, Southwark—Improvements in steam-boilers.
1367. Thomas B. Daft, Isle of Man—Improvements in inkstands.
1368. Richard Robbins, Dunehurk, Warwick—Certain improvements in mills for grinding wheat and other grain.
1369. James Hayes, Elton, Huntingdon—Improved machinery for raising and stacking straw, hay, corn, and other agricultural produce.

1370. William E. Maude, Liverpool—Improvements in carriages.—(Communication.)
1371. William E. Maude, Liverpool—Improved apparatus for steering ships.—(Communication.)

Recorded June 4.

1372. Carol F. Lenz, Berlin, and 52 Great Titchfield-street—Invention of a mechanism of a new construction, having as its end the prevention of the loss of force caused till now by friction, to diminish the oiling till now necessary, and to prevent the heating of the axle-trees in revolving.—(Partly a communication.)
1373. William Bradburn, Sbfinal, Salop—Improved manufacture of greases and oils.
1374. Joseph Gyde, Tooley-street, Southwark—Improvements in mills and apparatus for grinding and dressing corn and various substances.
1377. Henry J. Betjemann, 545 New Oxford-street—Improvements in chairs.
1378. Edward B. Beaumont, Woodhall, Barnsley—Certain improvements in bricks or tiles.
1379. Joseph Burch, Crag Hall, near Macclesfield—Certain improvements in fans, blasts, or blowing apparatus.
1380. William Dray, Swan-lane, London-bridge—An improved method of driving shafting.
1381. Benjamin Bram, Wentworth—Improvements in working and ventilating mines.
1382. Thomas R. Nash, Leigh-street—Improvements in filters.
1383. Christian Schiele, Oldham—Improvements in pressure-indicators.
1384. John Whitehead, Preston—Improvements in manufacturing pipes or hollow articles from plastic materials.
1385. Thomas Richhell, Lamheth—Improvements in the application of slate for building purposes.

Recorded June 6.

1386. George Carter, Nottingham, Kent, and George Marriott, Hull—Improvements in the manufacture of white lead.
1387. Joseph Gundry, Bridport—A certain improvement in the manufacture of fishing and other nets.
1389. Anthony B. B. Von Rathen, Wells-street—Improvements in the mode of, and in engines for, applying motive power.
1391. Christopher Nickels, Albany-road, Camherwell, and James Hohson, Leicester—Improvements in weaving.
1393. Henry Wigglesworth, Newbury—Improvements in connecting together or coupling railway carriages.

Recorded June 7.

1395. Henry G. Rowe, Albert G. Andrew, and William H. Andrew, Sheffield—Improvements in the mode of fastening the handles of table knives and forks.
1396. Frederick Lipscombe, 233 Strand—Improvements in the construction of ships and boats.
1397. Edward Lavender, Deptford—Improvements in the manufacture of fuel, and in machinery connected therewith.
1398. Alfred V. Newton, 66 Chancery-lane—Invention of a novel construction of apparatus to be used as a chest-expander and as a uterine or abdominal supporter.—(Communication.)
1401. Robert B. Cousins, 50 Halford-street, Islington—Improvements in the manufacture of casks or wooden vessels.

Recorded June 8.

1402. Frederick L. H. Danchell, Elm Grove-villas, Acton Green, and William Startin, Heathfield-terrace, Turuham Green—An improved mode of obtaining aeriferous deposits from the beds of rivers and lakes, and from pits containing water.
1403. George Tillet, Kentish Town—Improvements in portable houses and buildings.
1404. John Horrocks, jun, and James D. Horrocks, Piccadilly—Improvements in the manufacture of detonating or percussion caps.—(Communication.)

Information as to any of these applications, and their progress, may be had on application to the Editor of this Journal.

DESIGNS FOR ARTICLES OF UTILITY.

Registered from 17th May to 15th June, 1853.

- | | | |
|-----------|------|---|
| May 17th, | 3459 | Humphreys and Thirst, Chelsea,—“Flap and drain-mouth for sewers.” |
| 18th, | 3460 | J. Mackay, Drogheda,—“Tubular boiler fire-box.” |
| 19th, | 3461 | Thornton and Son, Birmingham,—“Lamp.” |
| 20th, | 3462 | J. W. and T. Allen, Strand,—“Writing-desk.” |
| 21st, | 3463 | G. Burt, Birmingham,—“Tallow-lamp.” |
| 23d, | 3464 | W. Battley and J. Rivett, Northampton,—“Clover-rubber.” |
| 25th, | 3465 | T. Otwell, Barnsbury,—“Camera.” |
| 26th, | 3466 | G. Turner and T. Mitchell, Bradford,—“Spring-machine fly assister.” |
| 31st, | 3467 | R. W. Winfield, Birmingham,—Gas-burner.— |
| — | 3468 | Mills and Whitaker, Oldham,—“Throttle-valve.” |
| — | 3469 | J. D. Brady, Hyde-park,—“Knapsack.” |
| June 1st, | 3470 | J. G. Reynolds, City-road,—“Arca-proteos, or emigrant's house.” |
| — | 3471 | J. Gillett, Birmingham,—“Pen-holder.” |
| 4th, | 3472 | C. A. and T. Fergusson, Poplar,—“Hawsc-plug.” |
| 10th, | 3473 | P. Tait, Limerick,—“Shirt.” |
| 11th, | 3474 | H. Olden, Birmingham,—“Silk preserver for work-tables.” |
| — | 3475 | F. Edwards, Poland-street,—“Heat-conductor.” |
| 15th, | 3476 | A. Sharland and J. Gotley, Bristol,—“Pressure-pump.” |

DESIGNS FOR ARTICLES OF UTILITY.

Provisionally Registered from 13th May to 11th June, 1853.

- | | | |
|-----------|-----|---|
| May 13th, | 511 | T. E. Moore, Great Titchfield-street,—“Double punch.” |
| 18th, | 512 | P. Moxham, Granard,—“Paddle-wheel.” |
| 20th, | 513 | J. G. Reynolds, City-road,—“Arca-proteos.” |
| 23d, | 514 | C. De Bergue, Dowgate-hill,—“Railway-bar.” |
| — | 515 | C. De Bergue, Dowgate-hill,—“Railway-fastener.” |
| 28th, | 516 | T. Bourne, Smithfield,—“Buckle.” |
| June 1st, | 517 | W. Parsons, Chelsea,—“Floor-cramp.” |
| 9th, | 518 | J. Ellison, Liverpool,—“Reclining chair.” |
| 11th, | 519 | W. Duckworth, Liverpool,—“Window-guard.” |
| — | 520 | Flanagan & Co., Liverpool,—“Hat.” |

TO READERS AND CORRESPONDENTS.

T. S. S. (Liverpool)—The process is still a secret, although many speculations have been afloat upon it.

T. A.—We do not see that the publication of his note would lead to anything but a private controversy, with which the world has nothing to do.

RECEIVED.—“The new Equilateral Triangular Telegraph.” By H. Dempster.—“Cl'g'g on Coal Gas.”—“Ellet on the Mississippi and Ohio Rivers.”

G. BOWER, PATENTEE,
STONEOT'S, HUNTS.

Fig. 1.

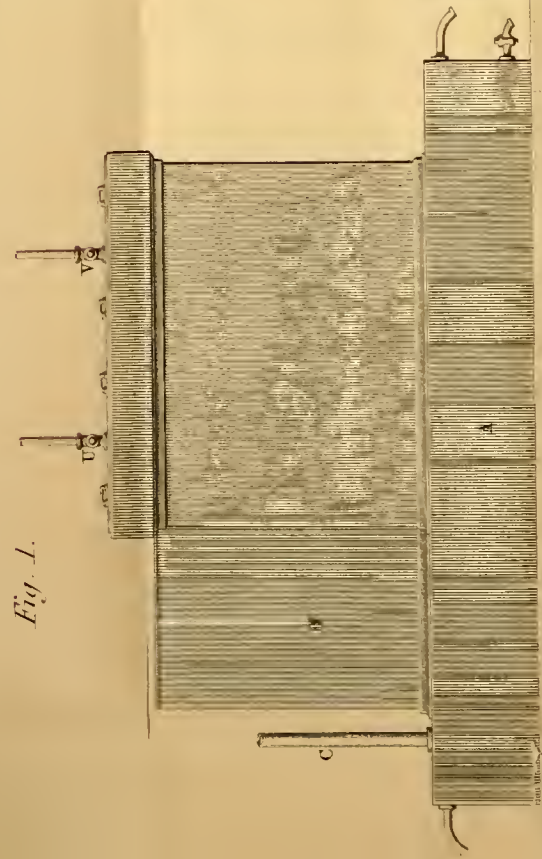

Fig. 2.

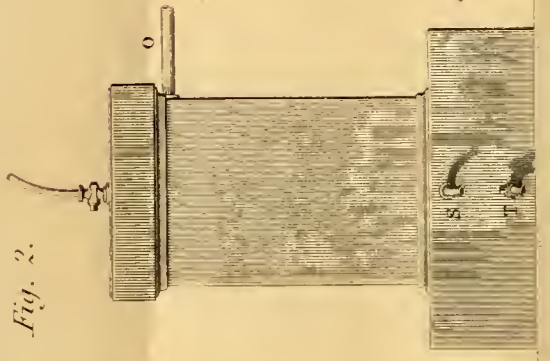

Fig. 3.

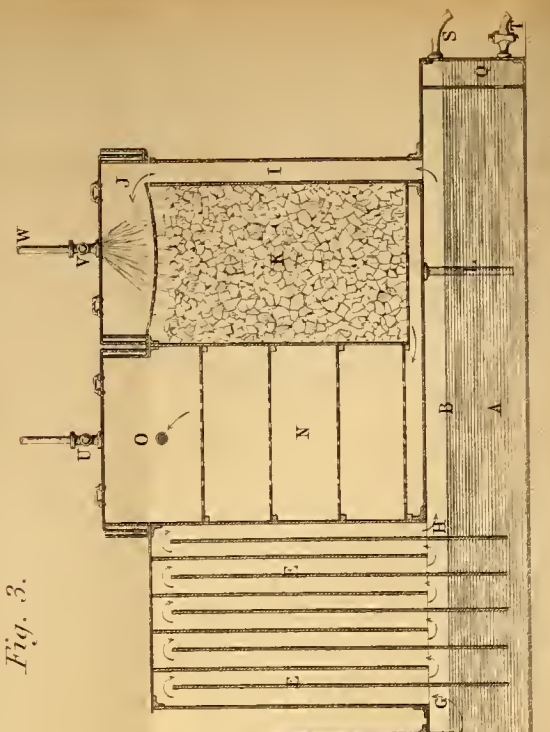

Fig. 4.

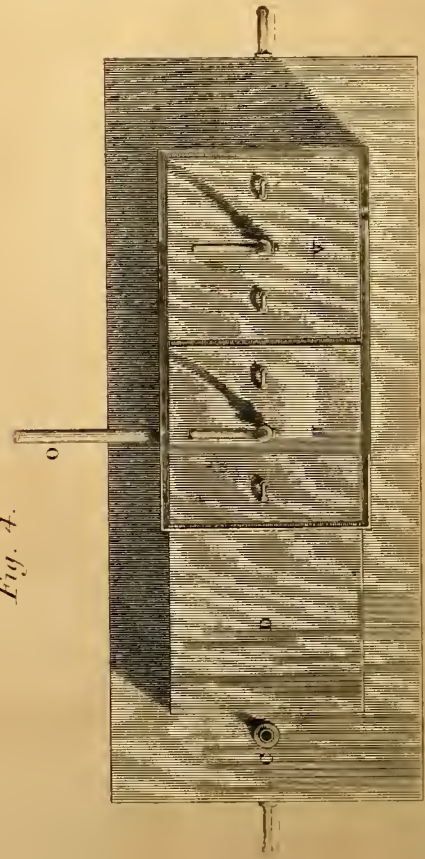

Fig. 5.

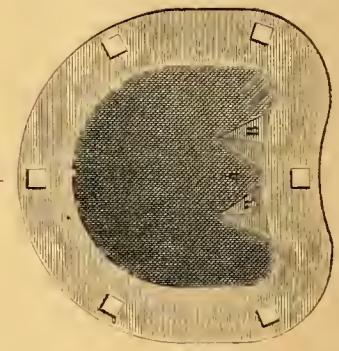

Fig. 6.

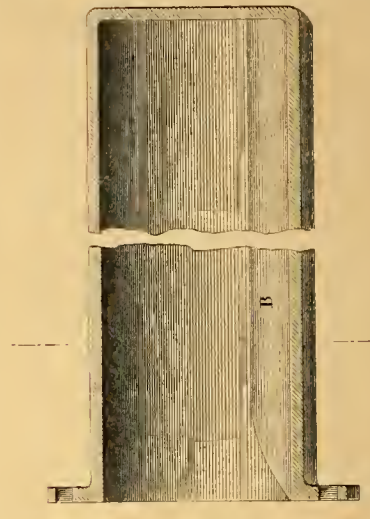
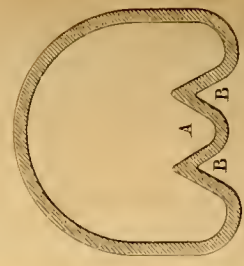

Fig. 7.



Scale for Figs 1, 2, 3, 4. $\frac{1}{16}$ th



Scale for Figs 5, 6, 7. $\frac{1}{12}$ th

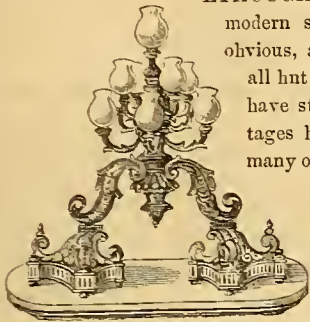

BOWER'S GAS RETORTS AND COMBINED GAS APPARATUS.

(Illustrated by Plate 132.)

ALTHOUGH the benefits derivable from the modern system of gas illumination are so obvious, and have been so pointedly felt in all but the most exceptional situations, we have still to regret that the offered advantages have been strangely disregarded in many of their most important applications.

The complete introduction of gas illumination into private dwellings, is even yet strongly opposed by ancient and ill-founded prejudices; but, as in all other cases of misconception, this difficulty is vanishing

as the world grows older, and its inhabitants gather wisdom. The gas engineer, then, must follow up his gradual accessions of points of advantage, by smoothing down whatever real objections there may be in his way. He has got a cheap material to deal with; he must see that it is pure and fit for developing that brilliancy of illumination which it is undoubtedly capable of affording, without at the same time entailing any unhealthy consequences, or such inconveniences as the generation of a disagreeably high temperature, or the discoloration of furniture and architectural enrichments. Much of the responsibility rests in reality upon the consumer, who too often forgets, in the splendour of the illuminating power at his command, that he is overtaxing his ventilating resources, by heedlessly introducing a light several-fold more effective than his former inconvenient oil-lamp, or still more troublesome array of candles, without taking into account the necessarily increased accession of heat which his prodigality has involved. But even here he has a wide margin; for, according to the most recent experiments as given in another page of our present impression, if we suppose the heat generated by the burning of a tallow candle to be represented by 100, that evolved from London coal gas, furnishing a corresponding equivalent of light, stands no higher than 47. With the same comparison, London cannel gas gives 32, whilst the Lesmahagow hydrocarbon gas is rated at no more than 19. Similarly, when tallow generates 10·1 of carbonic acid, the ordinary London coal gas gives only 5.

No amount of care at the head-quarters of the gasmaker can possibly make up for domestic negligence at the scene of consumption; but it ought to require a faint show of argument indeed, from us, to satisfy even prejudiced observers, that, with the most trifling attention, no house can be so efficiently and economically lighted in every room, from the kitchen to the saloon and houldoir, as by the ordinary gas which is to be found in every town. If we are to make exceptions to this assertion, we admit them only in the case of small isolated manufactories, or country seats, which may be commercially inaccessible to the approach of the pipes from the public gas manufactories. It is for such excepted situations that the apparatus, delineated in our Plate 132, has been devised. That contrivance is the patented invention of Mr. George Bower, of the Vulcan Foundry, St. Neot's, Huntingdonshire, and its object is to bring a compact and easily manageable coal gas apparatus within the reach and government of every owner of a private house, or factory, whom position may have hitherto condemned to use the inferior sources of light.

In this arrangement, the retort in which the coal is placed is made with projecting triangular surfaces, so that the coal to be distilled is exposed to an enlarged heated area, and is, therefore, more rapidly carbonized than in a retort of the ordinary kind, whilst the production is increased. In the complete apparatus, the hydraulic main, washer or scrubber, and condenser and purifier, are all combined within one arrangement, so as to insure a degree of compactness and simplicity

unattainable in disconnected apparatus. Fig. 1 on our plate, 132, is a longitudinal side elevation of the combined apparatus. Fig. 2 is an end view at right angles to fig. 1. Fig. 3 is a vertical longitudinal section of the apparatus. Fig. 4 is a plan of the whole. Fig. 5 is an end elevation of the mouth of the improved retort. Fig. 6 is a longitudinal section of the retort, as broken away at the central portion. And fig. 7 is a transverse section of the retort. The base of the apparatus forms the hydraulic main, A, the line, B, representing the level of the deposited tar. The gas is supplied to this receiver by the dip-pipe, C, which proceeds directly from the retort ascension-pipe. The condenser is delineated at D, having five vertical plates, E, dipping into the fluid beneath, and alternated with four other plates, F, attached to the top of the condenser, and hanging down to the level of the top of the hydraulic main. The dipping plates, E, being left free or open at the top, a clear but circuitous passage is left for the gas, as indicated by the arrows, the entry to the several divisions being at G, and the point of exit at H. Hence the gaseous current passes along the bottom to the division, I, up which it passes, and again descends as at J, over the top of the washer, or scrubber, K. In the bottom of this washer, or scrubber, is a small pipe, L, to take off the deposit of tar and water from the washer to the hydraulic main. The partially cleansed gas then passes on, as at M, to the bottom of the purifier, N, whence the gas escapes by the outlet branch, O, to the gas-holder. Siphon traps, P Q, are fitted at each end of the base, and the pipes, R S, take the surplus tar to the tar well. The entire contents of the hydraulic main may be drawn off by the pipe, T, which is attached to a plate capable of removal when the hydraulic main wants cleaning out. Access to the purifier and washer is obtained by the movable lids or covers, U V; the coke in the scrubber, or washer, may be washed by water conveyed therein through the pipe, W. In this way the whole of the apparatus for the treatment of the gas, as it comes from the retorts, is effectively combined within the limits of a single solid base. In figs. 5, 6, and 7, the enlarged bottom-heating surface of the retorts is shown at A, the ridge surfaces, B, furnishing a large area, as compared with the ordinary form of retort. These ridges are, in this instance, two in number, and they extend from end to end of the retort, but are beveled off downwards at C, at the mouth, for the convenience of charging; but such ridged bottoms may be made of various other forms.

The compactness and simplicity of this apparatus are clearly obvious from our Plate, which represents the special construction adopted by the inventor for all purposes, where a maximum of 100 lights is required. The corrugated or ridged retort bottom is applicable, of course, in all manufactories. By its use, it is stated that small coal may be carbonized in one-fourth less time than at present, by reason of the addition of some thirty-five per cent. more heating surface, in comparison with the flat bottom. This modification necessarily effects a saving not only in time, but in wear and tear and labour, as well as in first cost, for the works need not be on so large a scale as would be necessary under the common arrangement. A saving of labour is also effected by the arrangement of the retorts, which are so contrived that, when one is worn out, it may be replaced without disturbing a single brick.

The results of Mr. Bower's improvements will be more forcibly felt, when it is remembered that the price of coals does not give the cost of gas; for the labour, interest on capital, and depreciation, form the chief items of expenditure, and whatever system will effect the greatest saving in these points, will produce the cheapest gas. Practical men also tell us, that the quicker a charge is worked off, the better is the gas; and the arrangement before us is undoubtedly entitled to considerable credit on this head alone. Mr. Bower has been experimenting more or less in gas-making for the last two years, during which time he has tried nearly every possible plan of producing artificial light, and his conclusion is, that coal alone is the best material for the purpose. In coal gas, the combination of hydrogen and carbon is such, that a similar

one cannot be effected with these constituents when in separate forms. It is true that water, which is really costless, will produce an illuminating gas when decomposed, and its hydrogen carbonized; but the cost of this decomposition in wear and tear and labour alone, for the production of the hydrogen—one only of the elements of which coal gas is made up—is actually more than that of highly illuminating gas produced from pure coal. In considering the late attempts at the production of resin, oil, or hydrocarbon gas, Mr. Bower decidedly denies their capability of competing with coal as gas-producing substances, even giving coal a range of price up to 50s. a ton.

We cannot but regard the results of Mr. Bower's labours as carrying the art to which he has devoted himself, a considerable step forward in the march of practical improvement—such a step as promises to be firm enough to afford a good base for further and more striking advances; for it is the fruit of that "new philosophy which never rests, which has never attained, and which is never perfect. Its law is progress. A point which yesterday was invisible, is its goal to-day, and will be its starting-post to-morrow."

THE LAW OF PATENTS FOR INVENTIONS IN THE GERMAN STATES OF THE ZOLLVEREIN.

The German confederation is composed of thirty-eight States, and of these twenty-five have formed a Trade League, known as the Zollverein. The States of this League are the following:—

- Kingdoms of Prussia, Bavaria, Saxony, Hanover, and Wurtemberg.
- Grand Duchies of Baden, Hesse, and Saxe-Weimar-Eisenach.
- Electorate of Hesse.
- Duchies of Saxe-Cobourg-Gotha, Saxe-Meiningen-Illdburghausen, Saxe-Altenburg, Nassau, Anhalt-Dessau, Anhalt-Bernburg, Anhalt-Coethen.
- Principalities of Schwarzburg-Rudolstadt, Schwarzburg-Sondershausen, Hohenzollern-Hechingen, Hohenzollern-Sigmaringen, Waldeck, and the two branches of the house of Reuss.
- Landgraviate of Hesse-Homburg.
- City of Frankfort on the Maine.

These States have agreed upon a general system of law with regard to letters patent, and this was embodied in a convention, dated 21st September, 1842, which was ratified the 29th June, 1843. The terms of this convention override the particular laws of the States, and hence it will be well to set out the convention before referring to the particular laws. It is expressly reserved to each State, to regulate the issuing of letters patent as it thinks fit, whether for original or for imported inventions, upon all points as to which the convention is silent.

Article 1.—Patents shall only issue in respect of such inventions as are new and original. Inventions already in use, or known in any manner whatever, within the limits of the League are not patentable; and especially those which have been so described in words, or by figures, in books published in Germany or abroad, that competent persons may carry them into effect.

Each State must decide for itself, as to the novelty and originality of inventions sought to be patented.

A patent having been granted to a subject of any State of the League, no patent for the same invention can be taken out in any other State, except by the original inventor, or the person lawfully succeeding to his rights.

Art. 2.—Subject to the preceding regulations, patents may issue for improvements in inventions already patented or known, provided that the improvement is real and original; but no prejudice shall thereby be occasioned to the patentee, and the patentee of the improvement shall have no claim to share in the profits of the original patentee.

Art. 3.—A patent confers no right upon the patentee to forbid the importation of articles similar to those patented, or the sale of such imported articles. Neither shall the patentee have any right to forbid the use of imported articles, except only when they are machines or manufacturing or industrial instruments, and not general articles of trade used by the public.

Art. 4.—Every government in the League has authority to grant, by patent, within the limits of its jurisdiction, the exclusive right of making and executing any particular article; and also the exclusive right of applying both a new process of manufacture, and new machines or instruments of manufacture, so that the patentee, as long as he possesses the patent, may prevent any one else from using the patented article or process, except when it has been obtained from him.

Art. 5.—Each State of the Zollverein will treat the subjects of the other States as its own subjects, both as regards the granting of patents, and the protection of the rights thereby obtained; but the grant of a patent in one State, shall not ground any right to a patent in any other State.

Whether an invention is or is not patentable in any one State, is a question to be determined solely by that State, which is not to be bound in this respect by the decisions of other States.

A patent granted by any given State, confers no right beyond the limits of that State.

Art. 6.—If, after the grant of a patent, it is made to appear that the invention is destitute of novelty and originality, the patent shall be forthwith annulled. When the invention was previously known only to a few persons who kept it to themselves, the patent shall be valid as regards all other persons, if there are no other causes affecting its validity.

Art. 7.—Every grant of a patent shall be forthwith made known in the official journals, with a statement of its object, the name and residence of the patentee, and the duration of the patent. And in the same way the prolongation of a patent, or its determination before the expiration of the term originally granted, shall be published.

Art. 8.—At the end of every year, the several governments of the States shall send to each other correct abstracts of patents granted in that year.

KILN-DRYING GRAIN.

It is not generally known, or at least it is not fully understood by general observers, that the existing system of drying grain in kilns, preparatory to grinding into flour, involves one of the most unhealthy of manufacturing operations. The cleansed grain, when denuded of its chaff and other impurities, must be thoroughly dried, or indeed crisply baked, in order to bring it into the right condition for being ground; for the grinding process is really a crushing and abrading action, the individual grains being reduced by a compound squeezing and rubbing motion, so as to shell out the kernels into flour, and clear them from their containing husk. Hence, unless the grain is highly dried, the stones would merely flatten the husk without detaching the flour, and the peculiar sharpness of the grinding surfaces would very soon be lost, by the filling up of the cutting interstices with the soft half-plastic mass. The process universally followed in this country, in this "kiln drying," is this:—The clean grain is evenly spread out upon a room floor, composed of minutely perforated tiles—the holes being run through the thickness of the tile—so that when the latter is laid flat down to form a flooring or pavement, a free passage is afforded for a multitude of minute streams of hot air from heated flues beneath the apartment. Then, as the grain cannot be spread very thinly, owing to the great area it would cover, the attendants are obliged to enter the kiln, and turn over the grain layer almost continuously. Whilst this is going on, a cloud of fine sharp impalpable dust rises from the grain, and attacks all the vulnerable parts of the workman in a most disagreeable manner. But it is on the lungs that this insidious enemy preys most savagely. It gradually kills, and stout hale fellows are soon reduced to a condition from which they can never recover, by this inhalation of dust, which we might suppose it would be so easy to repress. But it is not so, under the present system. Can we not devise a better one? Both steam and heated air, properly applied, seem to afford the means of drying grain, without the necessity of the workman exposing himself for a single instant to the deleterious atmosphere which he is at present forced to brave.

Viewing the matter in this way, Mr. Sylvester Marsh, of Chicago, U.S., has made extensive experiments with heated air as the drying medium, and he has been thereby induced to embody his ideas in an actual working kiln of large size, now in operation. He forces hot air through the grain by air-pumps, worked by a steam-engine. The grain is spread out to a depth of four inches on a sheet-iron plate, of about twenty feet in diameter, and thickly perforated with small holes. The plate is carried on brick walls, five feet in height, arranged to enclose a wide space between them beneath the grain. This recess contains a stove, with an extensive ramification of flue-pipes attached, so as to form a powerful heating chamber for the cold air, which is pumped into it from without. As the air is thus forced in, it becomes well heated, and, in its efforts to escape, it passes up through the perforated plate, and thus acts with a powerful drying effect upon the mass of grain above. The plan is said to be successful, but a difficulty is at once apparent to us in it. There is no agitating action, and we do not see how any air-blast, however powerful, can make up for this essential want. Indeed, with the exception of the idea of forcing the air through the mass, the system differs little from our own bad plan. Besides, there is the inconvenience of the holes getting filled up.

Another idea, of considerably older date, has been patented in this country by Mr. Bethell, for the preservation of grain of various kinds, but it seems to us to be capable of adaptation in the kiln-drying process, with some minor modifications.

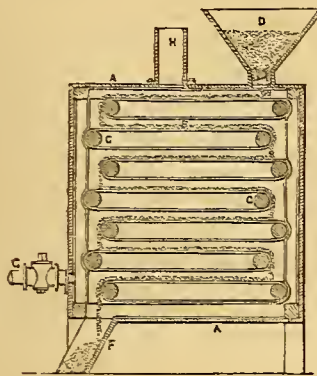

In this arrangement, which is represented in vertical section in the annexed figure, the effects of dried steam and mechanical agitation are combined. It consists of a rectangular case, A, in which are placed a set of endless cloths, B, mounted on rollers, C, which are made to revolve at a constant uniform rate. The grain to be dried is fed into the apparatus through a hopper, D, in the bottom of which is a small fluted roller, E, for the purpose of keeping up a constant and regular supply, the grain being made to fall from the discharge aperture of the hopper, on to the highest of the endless cloths. Then,

as this cloth slowly traverses forward, the grain so supplied is carried to the opposite side of the box, and here it falls over the carrying roller, on to a second cloth, moving in the reverse direction. In this manner the grain is carried several times back and forward across the apparatus, until it ultimately falls into a delivering spout, F. As the grain passes through, a current of dried or surcharged steam, diluted if necessary with air, is admitted into the case by the pipe, G. The steam and other matters escape through the overhead pipe, H. This contrivance is simple, and the miller will see that, whilst it removes all objection as to the health of the workman, it materially economizes the cost of the process.

HARMAN'S TUBULAR-FRAMED HOIST.

An excellent system of framework for large hoisting machinery, such as is suitable for dry docks, the erecting shops of engineers, and quarries,

Fig. 1

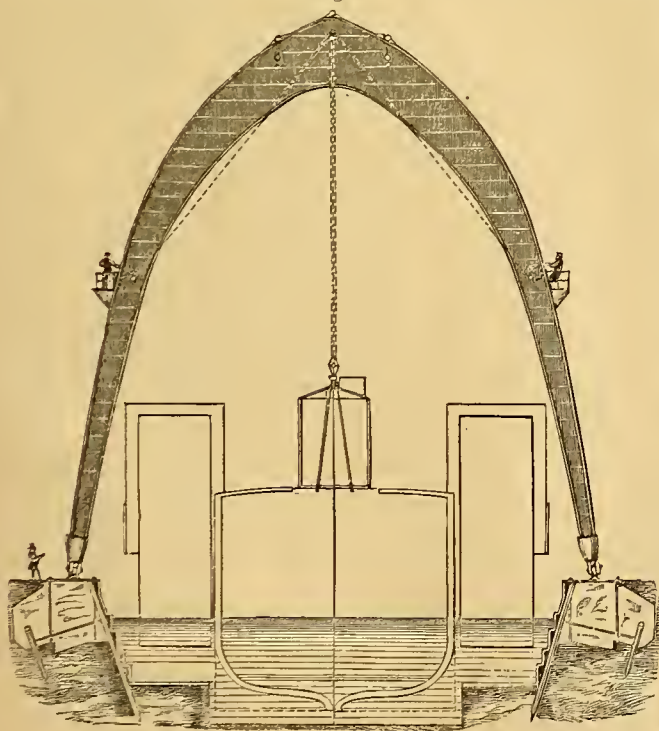

has just been designed by Mr. H. W. Harman, C. E. of Northfleet dock-yard; taking advantage of the important points of strength and lightness involved in tubular or cellular wrought-iron framing, as contrived for

traversing in extensive works. The framing consists of two parabolic arches, built of wrought-iron plates, riveted together, the arches being made to converge at their apices, where they are united by wrought-iron plates.

This forms a species of pyramidal erection, supported on four expanding legs, or standards, spanning the dock, or the object to be lifted, with two legs on each side, connected transversely by hollow beams or junction pieces. These hollow beams also form chain lockers. The actual mechanism of elevation, as the common "crab," or other lifting movement, is conveniently carried on the transverse beams, whilst the hoisting blocks are hung from the crown of the arch of the main framing, and are at all times protected from the weather. Our engravings exhibit a "great wrought-iron traversing dock-crane," constructed on this system, to lift 100 tons over a span of 90 feet. Fig. 1 is an end elevation of the crane, as erected over a steam-ship dock, shown in transverse section. Fig. 2 is a corresponding side view of the crane.

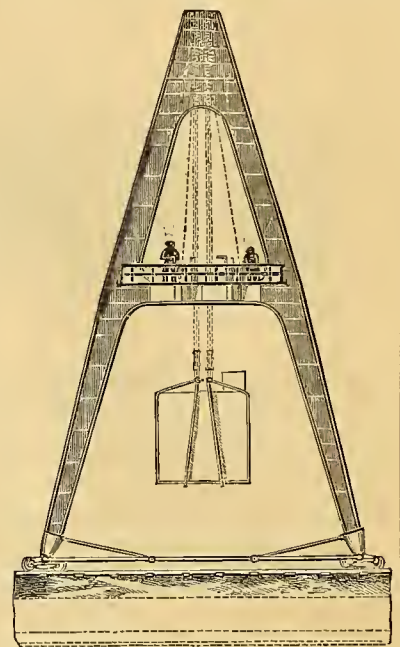

It is carried on a rail of a peculiar construction, laid along each parallel edge of the dock, each of the four legs being carried thereon by a pair of traversing wheels, set in brackets, forming the supporting feet, and connected by trussed tension-rods extending from one leg to the other. The whole of the interior is easily accessible for repair, and the men ascend by a ladder-way up the legs, to the platform on which the crabs are fixed, and this way is continued up to the blocks above.

It is obvious, that whilst this system of crane affords every advantage in point of stability and strength, it is worked with great facility, both in its traversing and hoisting movements, and its operative details are most conveniently and compactly disposed.

SIEBE'S CYLINDRICAL PAPER-KNOTTING MACHINE.

This is not a machine for tying knots in paper, as its name might apparently imply, but a contrivance for the separation of the "knots" and foreign matters from the fluid pulp from which paper is made. It is the invention of Messrs. Siebe, Steiner, & Mannhardt, of Denmark Street, Soho, and is intended to remove the several objectionable points in the old knotting machines—of their allowing the smaller knots and other extraneous matter to fall through—their keeping back the long stuff—the difficulty of removing the knots from the surface of the strainer—and the danger of thereby forcing part of the same through.

Among the advantages which the new machine possesses, is the thorough manner in which it separates the knots and other injurious substances from the pulp, forcing the latter, of any required fineness, through the sieves or strainers; and that, although it possesses great forcing power, the length of the stuff is in no way destroyed; from which it follows, that a much stronger paper is produced, with a smaller loss of stuff, than by any previous mode of straining pulp; also, the ease with which the knots may be removed from the strainers, without stopping the machine, or even the danger of breaking the paper, and without any loss of stuff; and lastly, that, without the loss of much time or trouble, the dividers can be altered so that a finer or coarser paper can be made.

In our engravings, fig. 1 represents a longitudinal elevation of a complete machine, taken partly in section; fig. 2 is a horizontal or top view of the same—portions in both being removed, to show the internal construction of the operating parts. At A are the strainers or sieves, composed of brass or other metal rings, to the number of forty or more, as may be required, smooth on the inner surface, but beveled and wedged on their outside periphery. The requisite number of these rings are drawn

together by vertical rods, with screws and nuts, which are passed through all the corresponding holes of the series of rings, which are so compressed as to form a cylindrical vessel, the passage for the pulp between

Fig. 1.

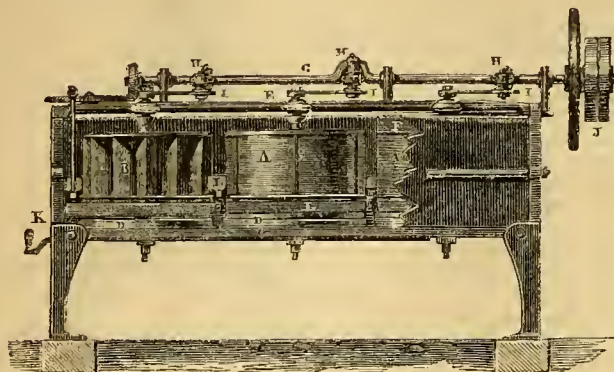

the rings being formed by thin plates or washers, called dividers, put upon the vertical rods between each separate ring. On the thickness of these dividers depends the fineness of the paper to be made; for, according to the width of the space between the rings, so will the pulp be more or less strained, and consequently the paper be of a finer or coarser quality.

These strainers—in this instance three—are inserted and fixed in the like number of rings, *d*, made fast by screws to the bottom of the pulp chest, *c*; a fan, *b*, as shown in fig. 2, is placed within each strainer, the pivot of its axle at the bottom being supported in a socket, inserted in the bottom of the pulp chest, and the upper part of the axle, turning

Fig. 2.

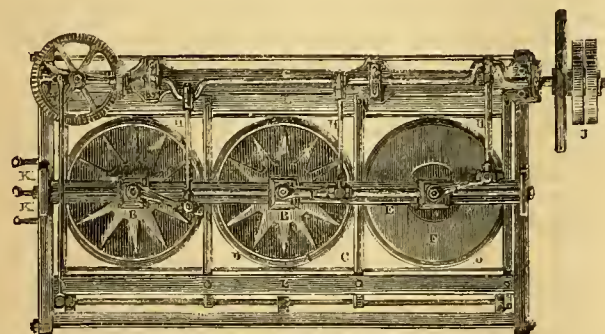

in a bearing in the longitudinal bar, *e*, fixed along the top of the chest. The covers or hoppers, *f*, for conducting the rough pulp into the strainers, are placed over the same, and suitable machinery applied to give the fans reciprocating movements on their axes.

The long horizontal shaft, *g*, has the necessary cranks formed on it, which cranks are severally connected by rods, *u*, to the ends of the respective levers, *i*, on the tops of the fan shafts. The driving power being applied to the pulley, *x*, to actuate the gear-work, the fans, *b*, will be put in rapid vibratory motion on their axes; and as they reciprocate, they agitate the pulp, which is now allowed to pour from above the machine into the hoppers, *f*. Thus, by the centrifugal force of the fans, the pulp is forced laterally through the space between the rings of the strainers into the pulp chest, leaving the knots and other injurious substances to fall to the bottom of the interior of the strainers, whence they may be drawn off at intervals, whilst the machine is at work, by means of slide valves, worked by levers attached to the handles, *k*, at the end of the machine.

In order to prevent the pulp from settling at the bottom of the chest, after it has passed through the strainers, perforated flap agitators, *l*, within the chest, are employed; these are moved by a suitable gear-work, attached to the end of the crank, which causes them to vibrate sufficiently to keep the pulp well mixed, without making a rough surface. It will be of course understood, that as the chest fills, the strained pulp will flow over the edge of the chest into the wire-cloth as usual.

WEEMS' MANUFACTURE OF PIPES AND SHEETS BY HYDROSTATIC PRESSURE.

The very marked success which has attended the carrying out of this valuable invention, has induced us to add to our former short notice* a more detailed description, assisted by engravings of the apparatus.

Fig. 1 is a sectional elevation of the modification employed by Mr. Weems in the manufacture of block-tin, lead, and composite metal pipes. The machine is entirely independent and self-contained, the hydrostatic pressure cylinder, *a*, resting directly on the floor, without any other fixtures. This chamber is cast open at the top, and closed in with a bored cover, held down by set screws, the large water pressure ram, *b*, working water-tight through this cover, which is fitted with a dished or cup leather ring for preventing the escape of water. The upper part of this water-chamber has also a deep projecting rib-piece cast on each side, and notched or recessed longitudinally at regular intervals, to receive the lower ends of the main wrought-iron tension rods, *c*, which pass upwards, and are similarly inserted in corresponding notched ribs, cast on the two opposite sides of the main resisting cross-head, *n*, overhead. The water-chamber and cross-head are further connected by two vertical side-pillars, situated between the chamber top and the lower side of the cross-head, and recessed longitudinally to admit the tension rods. In this manner a very firm connection of the main details of the machine is obtained by simple means, both ends of the tension rods having solid heads, so that, when the rod ends are heated and slipped laterally into their grooves in the main castings, the contraction consequent on cooling causes the heads to form firm bearings to hold up the water-chamber and cross-head firmly against the ends of their side pillars. The interior of the water-chamber is lined with brass or copper, the escape of water behind which is prevented by cup leathers at top and bottom, and the lower end of the main pressure ram being expanded or formed as a piston, it has a pair of cup leathers as packing for the upper and lower sides. The port for the admission of the water from the force-pumps is at *e*, and a second port is formed above at *f*, for pumping in water above the piston portion of the ram, for the purpose of returning it downwards when the charge of metal is exhausted. The metal, as block-tin or lead, to be used in forming the pipe, is contained in the traversing chamber or receiver, *g*, which rests on the top of the water pressure ram, *b*, and is held down thereon by a ring of bolts. These bolts have their heads inserted laterally into suitable holding slots round the bottom of the metal receiver, whilst their lower ends pass through a ring, *u*, and are secured by nuts beneath,—this ring being in two halves, and elamped into a ring groove formed round the head of the ram. The cylindrical core bar, *j*, acting as the mandrel for shaping the pipe's bore, is placed accurately concentric with the axial line of the metal receiver. The fixed tubular piece, or stationary ram, *k*, carrying the die or external shaping ring, is formed with a flange at its upper end, by which it is attached by the ring of bolts to the under side of the cross-head, *d*. The external diameter of this tubular piece is slightly smaller than the bore of the metal receiver, *g*, and its lower end is made with a shoulder, fitting exactly to the bore of the receiver. This shoulder, in conjunction with the inner ring of steel, forms the resisting pressure surface against the metal in the receiver. The actual shaping surface of this die ring is an inner shoulder, turned out of the ring, the bore of this shoulder being just as much larger than the diameter of the core bar, *j*, as the thickness of metal of the intended pipe, *l*, requires. The actual operation of this machine is similar to that of existing machines of this class. In commencing to work, the ram, *b*, is let down to the bottom of its cylinder, and the top of the metal receiver, *g*, is then clear of the die above.

In this state the receiver is charged with its supply of lead or tin, and the ram, *b*, being then forced upwards by the pumping action, the sur-

Fig. 1

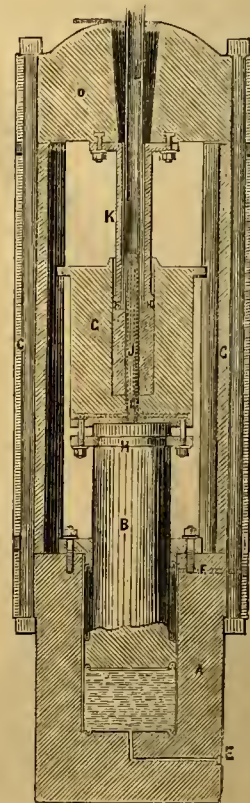

face of the contained metal becomes powerfully pressed against the die; and having no other means of escape, it exudes in the form of a pipe, L, through the narrow annular outlet between the core bar, J, and the shoulder of the die ring. But the essential distinctive feature of this system of construction is, that the core bar is fixed in the metal receiver, and therefore travels with it, along with the contained metal, so that there is no actual frictional contact except at the point of escape of the exuding metal; and the shaping die is pressed merely against the surface of the mass of metal, so that just so much of the mass of metal is caused to ooze through or between the die and core, as will produce the amount of pipe due to each increment of motion of the die, without, in any way, disturbing the rest of the metal, or giving rise to any frictional effect elsewhere.

In the core bar, J, in fig. 1, a small passage will be observed dotted in, entering at one side, passing up the interior of the bar to near the end, and then returning and passing out at the other side. This passage is for the circulation of a stream of cold water, to prevent the bar becoming too hot, when the metal acted upon is of a nature requiring it to be worked in a highly-beated state.

Fig. 2.

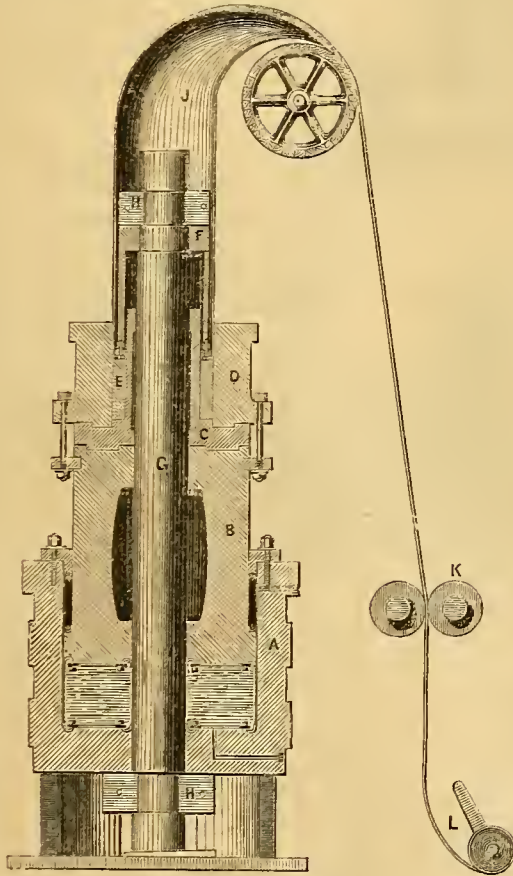

The machine, as constructed to manufacture sheets of lead or other metals, is represented in sectional elevation in fig. 2. The hydrostatic pressure cylinder, A, formed in the same way as in the other machine, rests upon an open base, and has fitted in it the large ram, B, on the top of which the centre piece, C, rests, by a base flange being bound or held in one mass with the ram and the metal receiver, D, by a ring of bolts passing through a flange on the receiver, and entering a ring let into a groove in the top of the ram. In this way an annular space is formed for the reception of the metal to be shaped, between the outside of the species of core piece, C, and the interior of the metal receiver, D. The metal receiver is, in this case, bored truly out to the outside diameter of the intended tube, which is made prior to flattening out in a sheet, so that the interior of the metal receiver is, in effect, the exterior shaping die for the pipe; whilst the pipe's bore is determined by the exterior of the core ring, recessed into and screwed against the end face of the fixed tubular core piece, F. This fixed core die is entered upon a shoulder on the upper end of the main centre tension bar, C, and is held

down by a clamping collar ring, H, made in two halves, to embrace a turned-out portion near the head of the bar. This bar is passed down through the centre piece, C, the ram, B, and the bottom of the hydrostatic chamber, A, below which it is secured by a clamping collar, H,—a thin wedge being placed beneath the end of the bar, to support and adjust it whilst the parts are being erected. In this way, when lead or other metal is supplied to the receiving space, E, the upward pressure of the ram, B, causes such metal to exude in the form of a pipe, J, between the core ring and the interior of the receiver, D. The metal so tubularly shaped may, therefore, either be used as a pipe of large bore, or it may be cut open longitudinally by a stationary knife, and gradually opened out by a wedge and passed over a guide roller, and thence between a pair of nipping rollers, being finally wound up at L, in its completely flattened sheet state. When the thickness of the sheet is to be altered, the core die, F, is released and lifted up, and the shaping ring is removed by taking out its holding screws. A ring of larger or smaller diameter is then substituted, just as a sheet of thinner or thicker substance may be wanted. Again, when the bore of the pipe is to be changed, the receiver and core die are both to be removed, and larger or smaller details of the same kind substituted.

Various forms of receivers and pistons, or compressing details, are also proposed for the purpose of making flat sheets direct by compression, without first making tubular pieces; the important principle kept in view, in all cases, being, as we before remarked, the concentration of the power employed upon the exact point of formation of the pipe or sheet, the material not being subjected to the slightest friction at any other part.

Mr. Weems' machinery is now in successful operation at the Chester Lead Works of Messrs. J. Walker, Parker, & Co.; one machine making lead-tin and composition pipes, from $\frac{1}{4}$ inch up to 1 inch bore; and another, making lead pipes from 1 inch up to 5. Similar machinery is also being fitted up at the works of Messrs. Newton, Keates, & Co., in Glasgow, and those of Messrs. Blaekett & Co., of Newcastle; and Messrs. Haldane & Rae, of Edinburgh, also have a foreign commission of a like nature.

ARTIFICIAL FUEL-WORKS AT BLANZY.

The cheapness of good natural fuel, in most parts of this country, has hitherto restrained our manufacture of all kinds of artificial fuel within very narrow limits. Still, the practicability of working up, into a valuable fuel, the small coal and coal dust resulting from mining operations, has at various times occupied the attention of engineers; and several manufactories, such as Wylam's, Warlieh's, and Bell's, now produce large quantities, but principally for marine purposes. For such a use, really good fuel of the kind possesses several advantages. It burns freely and with little smoke, and is easily stowed away. But as coal rises in price—and we have just now a foretaste of such a change—the artificial production must have a better chance of adoption; for, by working up the accumulations of minute fragments of coal now at the pit mouths, some check may be brought forward against extravagant prices, whether resulting from circumstances connected with the colliers themselves, increased consumption, or expensive carriage to remote districts. It is now more than fifteen years since M. E. Marsais, engineer, and director of the coal mines of St. Etienne, in France, put in practice a most ingenious plan of thus economizing coal dust. His system has since been extensively used both in this country and in France. Our illustrations exhibit the whole process, as adopted at the coal mines of Blanzay. The coal dust is submitted, in the first place, to a thorough washing in a tank, A, fig. 1. This tank is fitted with a horizontal perforated diaphragm, B, beneath which it communicates, by a large pipe, C, with a pump, D, of rough and simple construction.

Fig. 1.

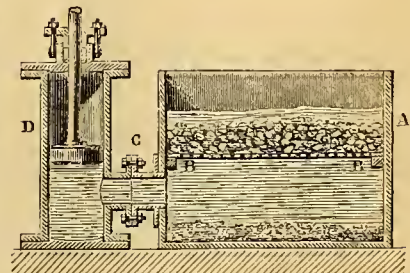

The tank being two-thirds filled with water, the coal dust is spread over the diaphragm, B, and the pump piston is set in motion. An alternate movement is thereby given to the water, and the coal dust is thoroughly washed, earthy matter, schist, and pyrites, falling to the bottom of the tank. When sufficiently cleansed, the coal dust is taken out and dried, and a fresh charge is put into the tank; and, when necessary, the matters deposited at the bottom of the tank are taken out by a

The tank being two-thirds filled with water, the coal dust is spread over the diaphragm, B, and the pump piston is set in motion. An alternate movement is thereby given to the water, and the coal dust is thoroughly washed, earthy matter, schist, and pyrites, falling to the bottom of the tank. When sufficiently cleansed, the coal dust is taken out and dried, and a fresh charge is put into the tank; and, when necessary, the matters deposited at the bottom of the tank are taken out by a

lateral opening, and the water is removed. The coal dust, washed and dried, is then passed between grooved rollers, to reduce it to a uniform size of grain.

Fig. 2.

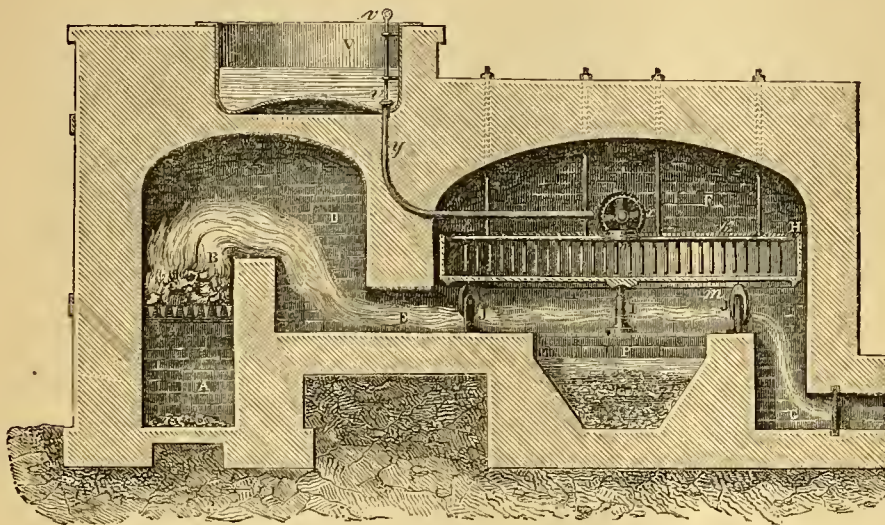

The material is afterwards mixed with seven or eight per cent. of pitch, in a heated state, and for this purpose the apparatus represented in our engravings, figs. 2 and 3, is employed.

It consists of a furnace, of which a is the ash-pit, and b the grate; the fuel is introduced by the door, c, whilst the air necessary for combustion is admitted by the door, d, to the chamber, e, and thence off by the flue, c. In the chamber, f, is a circular cast-iron receptacle, n, for the material to be operated upon, and this revolves upon a central pivot, j, and wheels, i, at the circumference, being actuated by a pinion, r, gearing with teeth upon the rim. A rake, k, is fixed across the centre by overhead rods and holts. The pitch is melted in a hoiler, v, heated by the flue, d.

The operation is as follows:—The coal dust, washed, dried, and rendered of uniform grain as described, is introduced into the receptacle, n, by the door, o, fig. 3, the latter revolving all the time, so that the coal

Fig. 3.

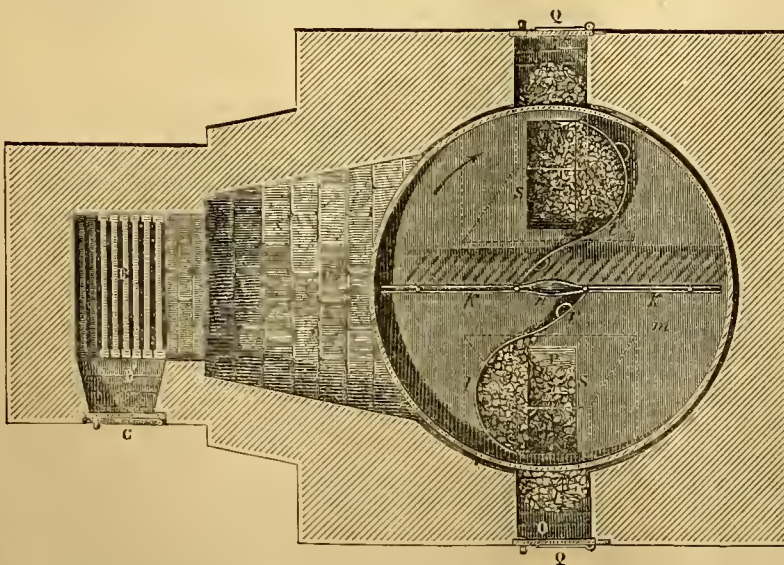

dust is spread uniformly over it, the stationary rake, k, tending also to produce this effect. When the temperature has reached about 200°, the valve,

v, of the pitch hoiler, v, is opened, and the pitch descends by the pipe, y, and falls into an elongated dish, n, formed on the top of the rake, k, and communicating with channels passing to each extremity of the rake. These channels are cut above the prongs of the rake, so that the pitch runs down upon the latter, and is thereby mixed with the coal dust in a very uniform manner. When sufficiently impregnated, the material is taken out; to facilitate which, a couple of stationary curved scrapers, t t', are let down into the receptacle, n; the continued revolution of the latter gathers all the material in front of the scrapers, and when in the proper position, a couple of traps, s, in the receptacle are opened, and the material is allowed to fall into the pits, r, whence it is taken out by the doors, q.

The material, still in a heated state, is put into cast-iron moulds, and submitted to a hydrostatic pressure equal to 45,000 lbs. This pressure produces a compact and solid mass, and when required for use, the cakes, or bricks, are broken up in the same manner as ordinary coal. This fuel is now extensively employed in the steamers on the Rhone and Saone.

DIRECT-ACTION INCLINED ENGINES OF THE "DUNCAN HOYLE" STEAMER.

By MESSRS. SCOTT, SINCLAIR, & Co., Greenock.

(Illustrated by Plate 133.)



NOT long ago, in presenting our elaborate plates of Messrs. Scott, Sinclair, & Co.'s "Double-geared Marine Engines,"* as since fitted to the *Clyde*, we illustrated what may fairly be considered as the latest improvement in geared engines for screw steamers. And we are not quite alone in our opinion in this matter; for, in addition to the Glasgow and New York steamer *Clyde*, precisely the same engines have since been fitted to the *Elbro* for the Barcelona and Liverpool, and the *Scindian* for the Pombay stations. We now perform

a similar service, as regards engines for general river purposes—whether in direct connection with paddles, or as geared screw engines—in our Plate 133, which represents an elevation and plan of the combined engines of the *Duncan Hoyle* paddle-ship, now employed in the Australian coasting trade, between Melbourne, Geelong, and Launceston.

The *Duncan Hoyle* was built by Messrs. John Scott & Sons, of Greenock, a firm as well and favourably known in connection with the past history and modern practice of naval architecture, as is that of Messrs. Scott, Sinclair, & Co. with marine engineering. This vessel measures 200 tons, her length is 145 feet, breadth 18 feet, depth 9 feet; and her engines, to which we are now directing attention, are of 90 nominal horse power. The two steam cylinders are each 37 inches diameter and 3 feet stroke, placed diagonally fore and aft the ship, and nearly at right angles to each other—the amount of divergence from the true right angle being a trifling extent due to the local necessities of the hull. They occupy a space on the vessel's floor of 15 feet fore and aft, by 5 feet 6 inches transversely—leaving ample room on each side of this latter narrow dimension for coal-hoxes, the cook's galley, and general fittings. A single stout sole-plate carries everything but the crank-shaft. This plate is cast with inclined face ends, to which each cylinder is bolted by corresponding flanges. The pistons each carry two piston-rods, disposed in the same vertical plane, and working through corresponding stuffing-hoxes in the upper cylinder covers, the outer projecting ends of the rods being

* See *Practical Mechanic's Journal* for April, 1853.

ENGINES OF THE 'DUNCAN HOYLE' STEAMER.

Plate 133.

MESSRS SCOTT, SINCLAIR & CO
GREENOCK.

Vol. VI.

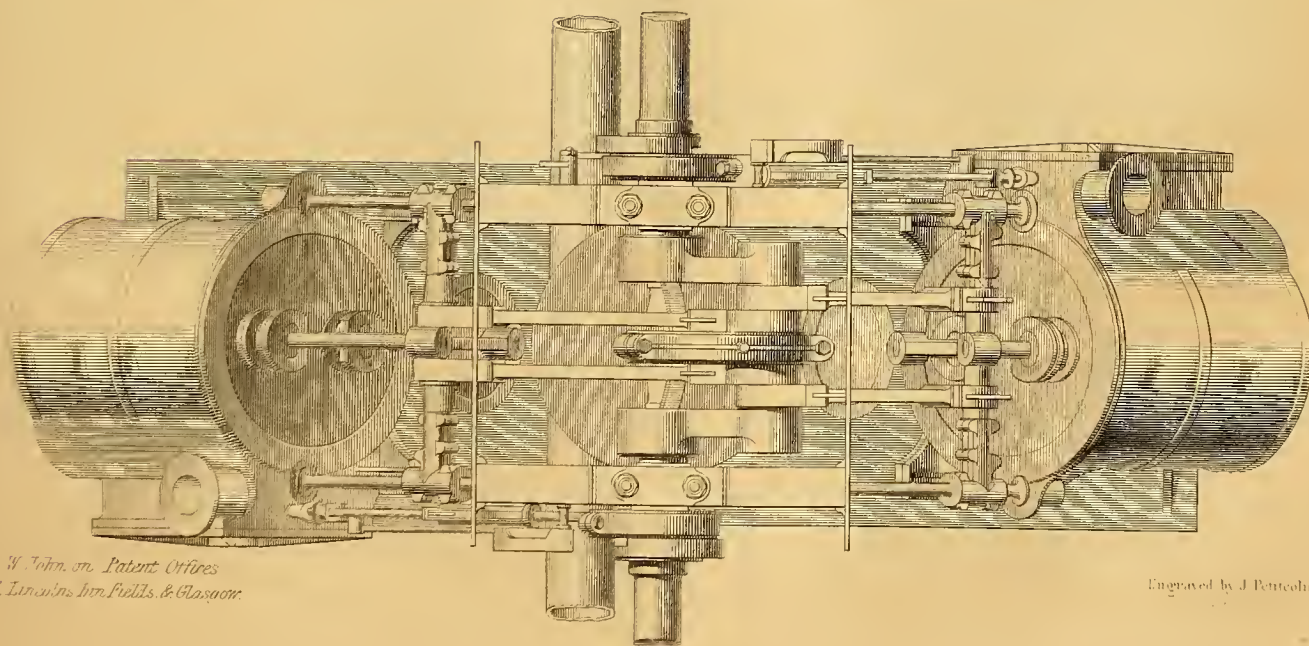
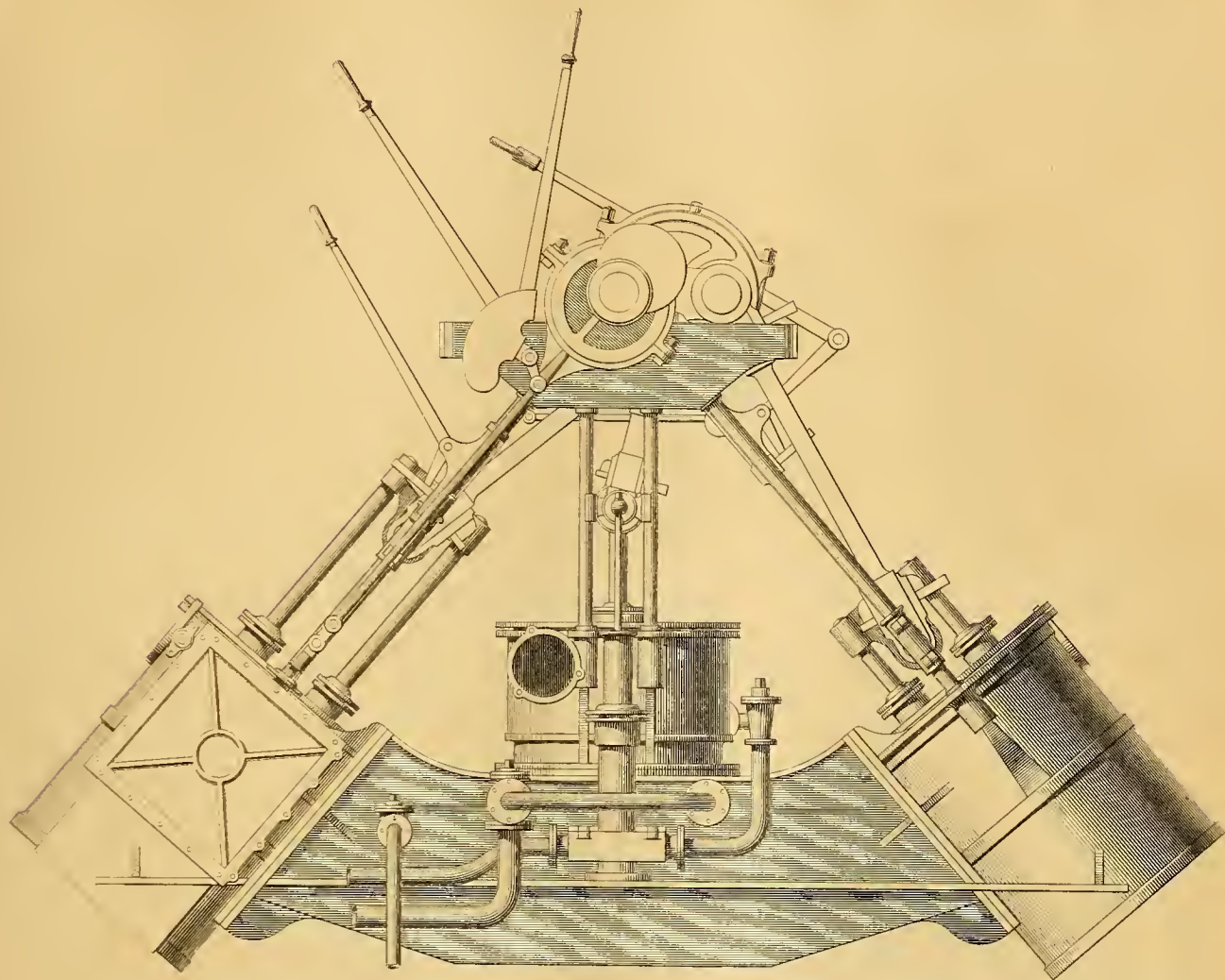

W. John, sr. Patent Offices
47, Lincoln's Inn Fields, & Glasgow.

Engraved by J. Pentecost.

SCALE
Inches 12 0 0 2 2 3 4 5 6 7 8 9 10 Feet
Mackay & Laird

connected by short transverse cross-heads. The entablatures carrying the crank-shaft are supported on eight wrought-iron pillars: four inclined ones, springing two and two on each side, from eyes cast on the upper ends of the cylinders, and adjusted in cutter sockets in the lower side of the entablatures; and four central vertical ones, similarly standing up from the top of the air-pump, between two steam cylinders. The short inclined cross-heads, connecting the piston-rod ends, are attached to the parallel motion guide blocks for the piston action, by means of horizontal transverse pieces, the combined cross-head being, in fact, of cruciform shape. It is these latter cross-bars which form the communication with the crank, and are the real working cross-heads for the connecting-rod action. Each engine has two connecting-rods, the details on each side being precisely the same, except that one pair of connecting-rods works inside or between the other, the two sets being set in corresponding positions on the horizontal cross-heads to suit; all the four rods pass directly to a single long crank-pin, their upper joint ends being strung upon the pin, with the air-pump eccentric in the centre, as best shown in the plan view. The inclined cylinder columns are turned and finished up to carry the piston-rod guide blocks, and they are thus "contrived a double debt to pay." The blocks are really T-socket pieces, cast in brass in two halves, and bored out together in two directions, at right angles to each other; so that, when clamped with bolts upon the cross-head ends in one line, and the guide columns on the other, they form very efficient guide bearings.

The steam-cylinder slides are on reverse sides of the cylinders in relation to their position in the ship. The slide valves are each worked by a single reversing eccentric, set on the crank-shaft immediately outside each entablature—the weight of the valves being balanced by short weighted levers, carried on studs on the entablatures, and linked to the valve spindles. The disengagement of the valves, and the reversing actions, are accomplished by the four lever handles represented in the elevation on our plate.

A single air-pump answers for both cylinders. It stands upon, and is recessed into, the centre of the sole-plate, which is cast with the condenser in it; and the pump-rod is guided by a cross-head, carrying guide blocks, fitting between the two pairs of vertical columns. From this cross-head, a connecting-rod passes up to a large eccentric on the crank-pin, the throw of which is reduced, to suit the air-pump stroke, by setting the eccentric so as to bring the actual working centre nearer to the axial line of the crank-shaft. This will be recognized as the same ingenious expedient which is adopted in the *Clyde's* engines. The feed and bilge pumps are worked from the air-pump cross-head, and they thus very conveniently occupy the space beneath the entablatures.

We have ourselves a strong feeling in favour of the oscillating engine for most marine and river purposes; but we admit the existence of some force, in what the designer of the *Duncan Hoyle's* engines urges on behalf of this fixed-cylinder, direct-action arrangement. He claims an especial feature of superiority, on the ground that the weight is better distributed, covering a large surface of the vessel's bottom; whilst all the parts are firmly and rigidly bound together, so that no one part can yield from another. For this latter reason, the loose-working, jingling action, not uncommon in old oscillators, can never arise in the engines now before us.

Captain Kincaid, the owner of the *Duncan Hoyle*, gives a most favourable account of her performances since she left this country, and particularly as a sea-boat, for she went out under canvas only. She is, no doubt, at the present moment, proudly fulfilling her destiny, in enlarging the boundaries of European civilization. For "the paddle-wheel," says Thackeray, in relating his steaming into Smyrna harbour,

"is the great conqueror. Wherever the captain cries, 'Stop her,' Civilization stops, and lands in the ship's boat, and makes a permanent acquaintance with the savages on shore. Whole hosts of crusaders have passed, and died, and butchered here in vain. But to manufacture European iron into pikes and helmets, was a waste of metal. In the shape of piston-rods and furnace-bars, it is irresistible; and I think an allegory might be made, showing how much stronger commerce is than chivalry, and finishing with a grand image of Mahomet's crescent being extinguished in Fulton's boiler."

SAMUELSON'S ROTATORY DIGGER.



UDGING from the determined manner in which farmers and agricultural implement-makers have adhered, for so many centuries, to that poetical antique,—but most superficial and unserviceable contrivance, the plough, it might very naturally be assumed, that there was some virtue in this system of shallow paring and slicing the soil. It was only when some superior observer hinted at the vast difference between the product of the market-gardener's spade-worked patch, and that of the old-fashioned plough-furrowed farm, that the sovereignty of the plough was laid open to discussion. Then came experimental competition trials, and elaborate tabular statements, showing that although, inch for inch, spade labour was triumphant, yet the productive gain was more than swallowed up by the costs of so much manual labour. So we went on year by year, giving premiums

Fig. 1.

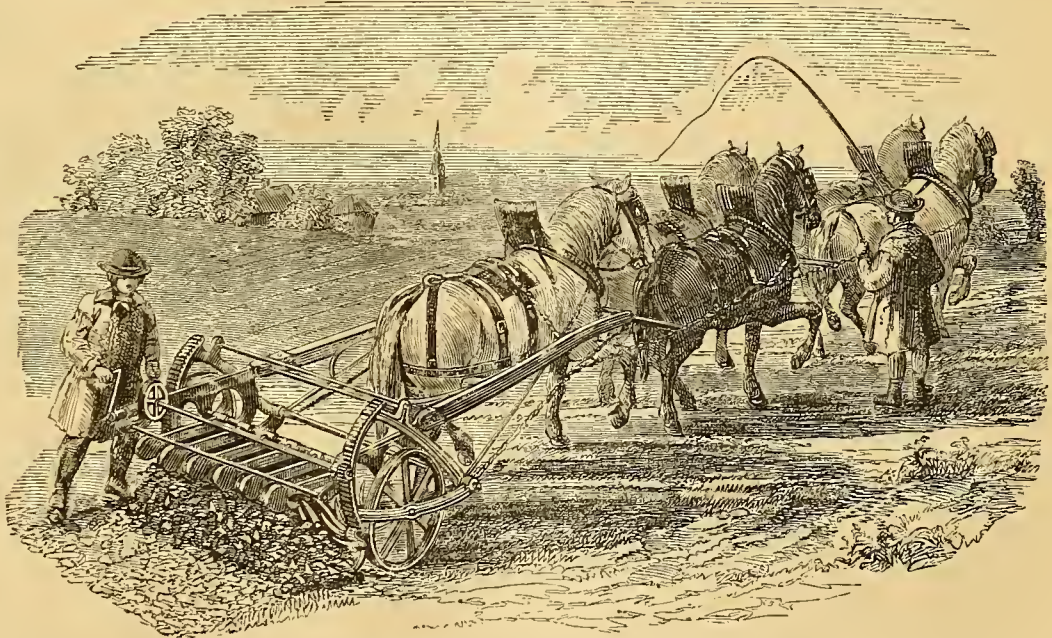

for curious intricacies of ploughs; and we still kept on turning over sheets of earth of some five inches thick, to be turned back again a few months later, or, at the best, to be tortured into something like tilth, by cross ploughing, rolling, grubbing, or harrowing. Then we had unwieldy steam-ploughs, some with the weighty engine going along with the massive ploughing machinery, and producing deeper ruts, with its wheels, than it furrowed out with the share; or we set a couple of engines, one on each side of a field, and hauled a plough back and forward by an intermediate chain.

All this was very wrong. If a human being to every spade did not pay, the matter was not much mended by the more complex applications of steam power to the ploughing-machine. The disintegrating principle was undoubtedly right; but steam was harnessed to it prematurely. Now we have another and more satisfactory looking scheme, in Mr. Samuelson's horse power digger, which we here engrave as in operation.

This machine, which is the invention of Mr. B. Samuelson, of the Britannia Works, Banbury, consists of a simple frame, running on a couple of wheels, and resembling an ordinary field roller. The weight and traction combined, as the apparatus is traversed over the land, causes a series of digging forks or prongs to dig into the earth; and thus, with five or six horses, according to the state of the soil under operation, two men are enabled to work down to something like eight or ten inches over a width of three feet, thoroughly pulverizing the soil, to the extent of five or six acres a day.

The perspective sketch, fig. 1, will give some idea of the appearance of the digger in the field; and the diagram, fig. 2, will serve to eluci-

Fig. 2.

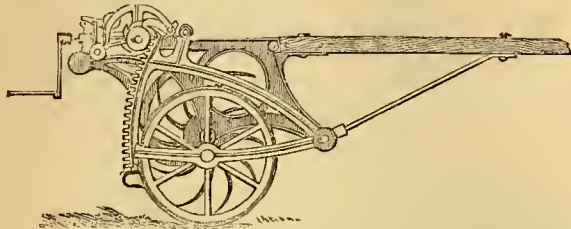

date its mechanical details. There is really very little mechanism about it. The running wheels are merely for carrying the apparatus at the proper level; and as the rotating forks penetrate into the earth, their depth of entrance is adjusted by a handle, geared to a pinion, working into a segmental toothed-rack on the framework. Perhaps it would be better to call it a forking machine, as the digging axle carries a series of independent pronged bosses, twelve teeth in each. These prongs are of comparatively slender steel, and they are so curved and shaped as to penetrate the soil pretty freely, by the mere weight of the framing. As the prongs come round, they bring up the soil, and let it fall backward, in a well-pulverized and mixed state, like the backwater from a paddlewheel; and, to keep them well cleared of earth, each circle of prongs works between a corresponding set of stationary clearing teeth on the frame. In the particular machine to which we refer, there are seven of these sets of prongs, each six inches apart on their axle; and the iron bosses are twelve inches in diameter, and four or five inches in width, the teeth being ten inches long. These bosses are put together in halves with bolts, so as to fasten the teeth securely; and between the bosses are loose heavy washers, for facilitating the working and cleansing of the machine.

In a late trial near Banbury, the ground was a friable calcareous loam, pretty stony, and lying fallow, after an autumnal ploughing, with here and there some couch-grass upon it. After the passage of the machine, the pedestrian sank in the soil, as he walked, up to two or three inches; and on testing it with a walking-stick, it showed a looseness down to eight or nine inches. In one case, five and a half acres were thus forked, with six horses, in 6¾ hours. Owing to the simplicity of its construction, it is not so expensive as to be beyond the reach of the occupier of farms of medium size; indeed it is already coming into very general use in England, and has been introduced into Scotland by the Messrs. Wilson of Berwick. The Royal Agricultural Society of England, at their recent meeting at Gloucester, acknowledged its merits by the award of their silver medal.

MECHANIC'S LIBRARY.

Architectural Drawing-Book, illustrated. London. 8vo., 2s. R. S. Burn.
 Architecture, Rudimentary—Styles, 1s. 6d. Bury.
 Arts, Manufactures, and Mines, Dictionary of, 4th edition, 2 vols., £3, cloth. Dr. Ure.
 Astronomy, Illustrated. London. 8vo., 2s., cloth. J. R. Hind.
 Electric Science, 8vo., 2s., cloth. F. C. Bakewell.
 Experimental Philosophy, Elements of, 8vo., 4s., cloth. J. Hogg.
 Geology, Principles of, 9th edition, 8vo., 18s., cloth. Sir C. Lyell.

Gold, Lectures on, 2d edition, post 8vo., 2s. 6d., sewed.
 Gold Mining and Assaying, 2d edition, foolscap 8vo., 2s. 6d., cloth. Phillips.
 Literary and Scientific Institutions, Essay on, 8vo., 5s., cloth. Hble.
 Locomotive Engine, new edition, 12mo., 4s. 6d., cloth. Z. Colburn.
 Magnetism of Ships, &c., foolscap 8vo., 5s., cloth. W. Walker.
 Marbling Book-edges and Paper, Art of, foolscap 8vo., 10s. 6d., cloth. Woolnough.
 Mathematics, Contributions to, royal 8vo., 7s. 6d., cloth. W. Shanks.
 Physical Science, Harmonies of, 12mo., 5s., cloth. Dr. Hinds.
 Practical Geometry, 2d edition, 8vo., 2s., cloth. R. S. Burn.
 Water Colours, Hints for Sketching in, 8vo., 1s., sewed. Hatton.

RECENT PATENTS.

SEED SOWING PLOUGH.

PETER FORBES, *Shettleston, Glasgow*.—Patent dated November 13, 1852.

This ingenious and valuable invention relates to the combination of a simple sowing apparatus with a common plough, in such manner that the three several operations of ploughing, or forming the furrow, the dropping of the seed, and the covering over of the seed with earth, may be all simultaneously accomplished, without involving either additional horses or attendance. A short transverse shaft is placed in suitable bearings across the plough, just behind the mould-board, and this shaft is fitted with a plain running wheel to work along the earth in the bottom of the furrow, in the track of the sole shoe. This shaft projects on one side, and has fast on such projection a small toothed pinion revolving in the bottom of a seed-holder, suited for all kinds of grain or seeds, and formed with a proper seed discharge aperture. The seed is dropped just behind the line of the mould-board, and immediately it is dropped part of the furrow is undermined by a secondary cutter or small mould-board, and made to fall over in conjunction with a portion of the previous furrow, and cover

Fig. 1.

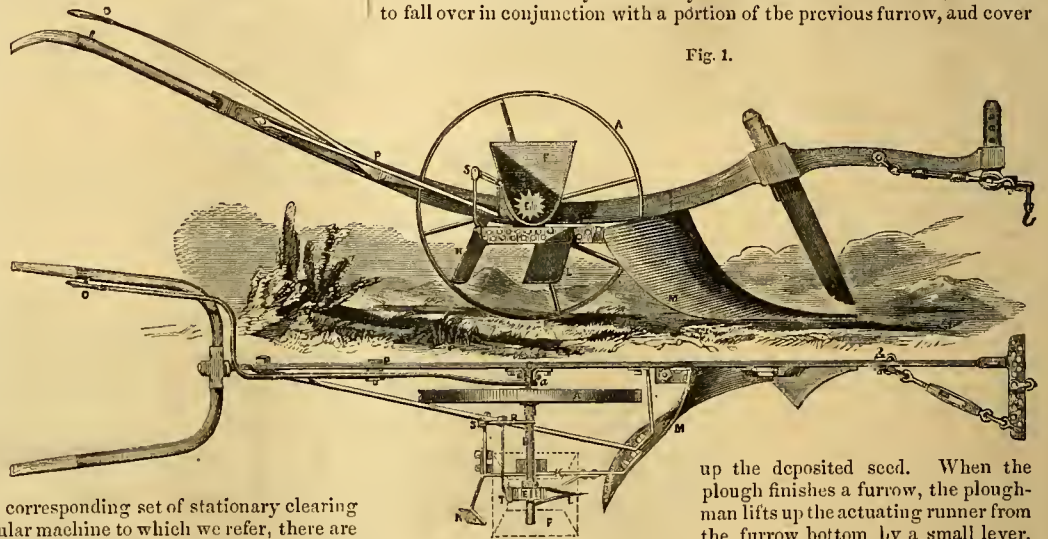

Fig. 2.

lifted by a suitable detent. This lifting action shuts off the discharge of the seed from the holder until the plough is turned and entered for a second furrow, when the lowering of the wheel again opens the seed discharge, and the operation goes on as before. The arrangement is capable of application to all kinds of ploughs, and may be used at any time of the year.

Fig. 1 of our engravings is a side elevation, partially sectioned, of a plough as fitted up for seed sowing in this way. Fig. 2 is a plan of the same, corresponding with one form of seed-box represented in dotted lines. Fig. 3 is a plan of a modification of the sowing apparatus as contrived for sowing potatoes, or comparatively large articles; and fig. 4 is a transverse vertical section of the same.

The large wheel, A, running in the bottom of the furrow, is fast on the short transverse shaft, B, carried at one end in the slotted bearing, C, on the main beam of the plough, and resting at the opposite end in a plate fast to the outside of the seed-sower; on the external projecting end of the shaft, B, is an adjustable toothed wheel or grooved pulley, E, working in the bottom of the seed-box or bolder, F, through which box the shaft is passed. This box has a sliding door fitted to it, so as to be capable of partially closing or shutting up the seed discharge aperture at pleasure; and it is attached to the plough by means of the hinged plate, I, which is attached to a corresponding piece of angle iron, which may be set back or forward on the perforated plate, K. At L is a small guide-cutter attached to the plate, K, just in front of the dropping seed, the line of which is thus marked out in the earth. As the plough

traverses the field, the main mould board, m, turns up the earth in the usual way, and the seed drops in the line of the inner face of the newly-exposed earth, as marked by the piece, l. Immediately that the seed has been thus deposited, the secondary cutter, or mould board, n, follows on, and, undermining the earth, covers up the seed. At o is the handle by which the ploughman regulates the implement at the end of his furrow. This handle is on the end of a lever turning on a stud centre, p, in the main beam, the other end of the lever having a fork, q, embracing the shaft, b. Whilst the sowing operation is going on, this lever handle stands up, as represented in fig. 1; but, when the sowing is to be stopped, the attendant depresses the handle, and fastens it beneath a catch on one

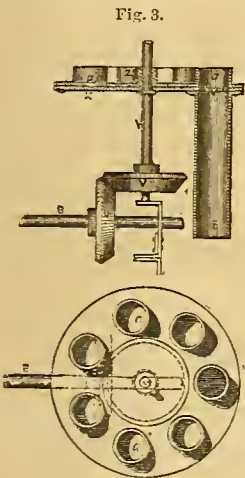

of the plough stilts, and this elevates and holds up the wheel, a, by traversing the inner end of the shaft in the slotted bearing, c. This angular movement of the shaft is allowed for at the seed apparatus, by the hinge in the piece, l. At the same time, the elevation of the shaft, b, lifts the forked end of the lever, n, embracing the shaft. This lever turns on a stud centre, s, and is slotted longitudinally to carry the rod of the valve, t, so that, as the shaft rises, this valve covers over the seed aperture, u, and stops the discharge until the shaft is again lowered. Various forms of sowers may be attached to the plough, which is thus capable of ploughing or turning up the earth in any condition, and depositing the seed at the same time. When potatoes or larger seeds are to be sown, the apparatus shown in figs. 3 and 4 is substituted for the sower which has been described. In this arrangement, the shaft, b, has placed upon it a bevel wheel, v, gearing with a corresponding wheel, w, fast on the lower end

of a vertical spindle, w, supported in hearings in the plough framing. The upper end of this spindle is passed through a flat disc of metal, x, perforated with a single hole, x, and this disc is stationary, the spindle revolving freely through it, and immediately above it is a similar disc, z, fast on the spindle, and perforated with a ring of apertures, a, each of the same distance from the centre of motion as the hole, x, in the stationary disc. Each hole in the upper disc has a shallow collar, and as the plough traverses over the field, an attendant deposits the seed potatoes individually in the holes, a, as they come round in the spindle's revolution. Then, as each of the holes, a, passes over the corresponding hole, x, beneath, it follows that each potato is dropped through the hole, x, and thence through the channel, b, into the furrow just made by the plough, as each individual hole, a, comes over the hole, x. In this way, by substituting discs with various "pitches" of holes, the seeds may be dropped at various determined distances asunder in the furrow, whilst the seeds so dropped may be covered over by the secondary mould board, as already described.

We have inspected various growing crops—beans, turnips, and wheat—sown by this machine, in Lanarkshire, and the regularity, luxuriance, and clear appearance of the plants were perfectly obvious. The wheat, indeed, is considerably further advanced than any other crop in the neighbourhood.

AGRICULTURAL STEAM-ENGINES.

W. ALLECHIN, *Globe Works, Northampton.*—*Patent dated Dec. 9, 1852.*

Mr. Allechin's improvements relate to the so arranging certain details of agricultural and other steam-engines, that a great portion of the loss ordinarily sustained from the radiation of the heat, and the condensation due to exposure to the atmosphere, may be prevented. In adapting this invention to a tubular boiler of the locomotive agricultural class, the barrel portion of the boiler, containing the flue tubes, is totally encircled by an annular steam jacket, or external steam casing, taking the place of the usual cladding. This steam space is kept supplied with steam by a pipe, led either from the exhaust passage of the engine, or direct from the boiler. In the special example given by Mr. Allechin, the waste steam is used for this purpose—the actuating cylinder of the engine being set in an overhead case, on the top of the firebox, from which case a branch pipe conveys the used steam direct to the enveloping casing. The hulk of the exhaust steam passes away to the engine chimney, to aid the draught in the usual manner. The cylinders and valves are wholly covered in by their casing; and as the waste steam is exhausted into the interior of the casing, all the parts requiring to be kept hot are thus well enveloped in

the heated vapour, and the loss by radiation and condensation is materially reduced; and this system of economizing fuel and steam affects as well the top of the outside fire-box, which is kept warm by the steam cylinder chamber set thereon.

SHIP, BARRACK, AND TELEGRAPH LAMPS.

MITCHEL THOMSON, *Surgeon, R.N.*—*Patent dated Oct. 5, 1852.*

We have already recorded the good services by which Mr. Thomson has so creditably distinguished himself in the improvement of shipping lights, and in particular in the arrangement of his "slush lamp for night signals, and the decks and masts of ships."* In this patent he has embodied all his recent improvements, which have been brought out in the course of a long-continued series of actual sea trials—of candle lamps suitable for lighting ships and barracks, and for telegraphic night signals—more especially when the sailors are using salt provisions. His aim has been to secure a simple and easily manageable light apparatus, which shall readily consume oil or fat, and economize the hitherto waste fat derived from the provisions of the sailor in cooking. Fig. 1 of our engravings is an external view of a ship's candle lamp of this kind. Fig. 2 is a longitudinal section of the lamp. Fig. 3 is a vertical section of a telegraphic night signal lamp on a larger scale, or a portable hand lamp of the same kind. Fig. 4 is a plan, and figs. 5, 6, and 7, are separate details of the wick-tube and holder detached. At A B are two metal tubes or cylinders screwed together at c, serving also to connect the candle lamp to the bottom of the lantern, and forming the main body of the lamp. Within the lower cylinder, b, is the freely-sliding cylinder, d, which is fitted with a leather packing, e, at its upper extremity. This packing fits tightly into the bore of the upper cylinder, a, thereby forming a piston for the purpose of pushing up the grease or fat, f. This piston is actuated by the spindle, g, and cord, h, or by an ordinary rack and pinion. The material proposed to be consumed in these lamps is ordinary fat oil, or the refuse fat obtained on board ship from the liquor in which the salt provisions have been boiled, and known to the sailors as "slush." Before burning in the lamp, the "slush" is clarified, and freed entirely from all saline particles, by washing with boiling water. It is put into the lamp in a cold state, like tallow, the upper cylinder being forcibly pressed down into the fat, and being entirely filled with it, forms a candle; this cylinder is then screwed on to the lower one, b, and as the upper surface of the fat is consumed, a fresh supply is brought to the wick, i, by winding up the piston, e. A number of these slush-holders may be kept ready filled, to be screwed on to the lower cylinder of the lamp as fast as they are emptied. A tightly-fitting cap, j, is attached by a pin and bent slot to the bottom of the lamp, to catch the drippings, in case oil should be used instead of fat. The peculiar arrangement of the piston for supplying the fat as it is consumed, and the construction of the wick-holder, form the principal features of the invention; and consist, in the first place, of a piston, as before described, and a wick-tube holder, k, as at fig. 5. This consists of a flat chamber, having a circular dished piece of metal, l, soldered to its upper edge. The sides of this chamber are perforated at m, to admit of the passage of the melted fat, or oil, to the internal wick. The wick itself is composed of several twisted strands of cotton, and is contained in the wick-tube, n, shown in its place in the chamber, k, in the section, fig. 6, and detached at fig. 7. This tube is also perforated at its sides; but it is made with an open bottom, to admit the grease more freely to the wick which it contains. o o, are two side wires, which are only required when the grease or oil contains impurities, and which are pulled up a short way when the lamp is lighted, in order that they may be heated by the flame, and consequently melt the grease below, which is in immediate contact with the wick. In trimming the

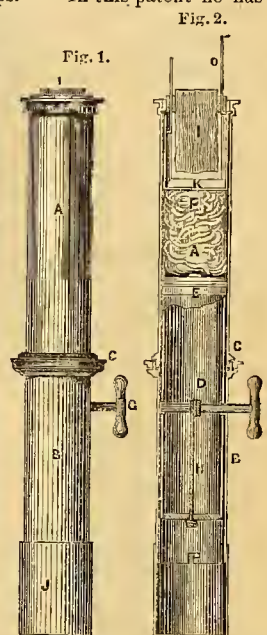

* Page 34, Part L., *Practical Mechanic's Journal.*

lamp, the new wick is well oiled, or greased, before insertion into the wick-tube, in order that there may be no difficulty in lighting it when required. In the small telegraphic signal lamp, or hand lamp, figs. 3 and 4, the use of a grease propeller, or piston, is dispensed with, the tube, A, being merely filled with fat, and the wick-tube holder, B, pushed into it. The cap, C, is then screwed on, and the wick-tube, D, with its

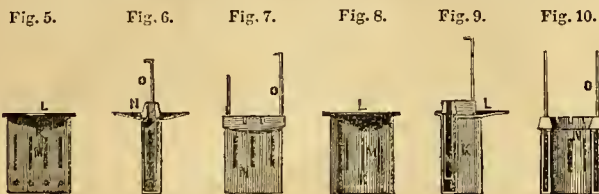

wick, is put into its place in the holder, B. Figs. 8, 9, and 10, are separate details of a wick-tube holder and wick-tube of a horse-shoe form, but made on precisely the same principle as the other burners.

It will be obvious that these lamps may be used with great economy, and that they are equally applicable to the decks and holds of ships, and to signaling purposes, and may be made of various forms, according as they are wanted, for hand or fixed lamps. The lamp shown at figs. 1 and 2 is intended to be screwed into a ship's deck lantern, and may be used in the ship's tops, decks, or cabins.

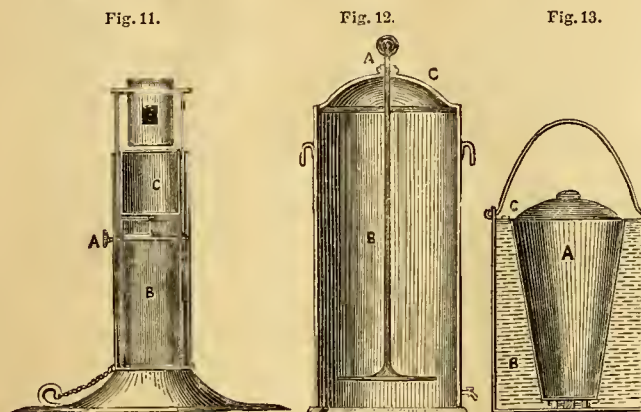

Fig. 11 is a vertical section of another modification of a portable lamp for naval and military officers. In this arrangement a pinion and band is added, for the supply of the grease; A being the pinion, B the band, and C the slush case.

Fig. 12 is a section of a slush-cleanser, to be used where there are no boilers or coppers. The cleansing-rod is at A, working down into the cleansing cylinder, B, through the lid, C. Three washings are sufficient, the grease being allowed to cool on the water's surface.

Fig. 13 is a grease-warmer for cold climates. The grease-holder, A, is placed within the hot-water receiver, B, the water for which is supplied at C.

Our last illustration, fig. 14, is a complete external elevation of a neat adaptation of the apparatus to a candle lamp. This lamp will obviate the necessity of purchasing candles or using oil, as, by means of it, any amount of light may be obtained from the combustion of ordinary fat, such as kitchen "drippings," and it will also readily burn oil, tallow, or lard. It will burn for a night without snuffing, and has neither smoke nor smell.

A variety of official reports have been made at the request of the Admiralty and Horse Guards, with reference to the use of

this light for army and navy purposes, all of which have been most satisfactory.

COMPOSITE METAL.

E. A. CHAMEROY, *Paris*.—*Patent dated January 3, 1853.*

This invention relates to an ingenious system of manufacturing a commercially valuable metallic compound, possessing the several properties or qualities of solidity, hardness, facility of soldering, melting at low temperatures, and tractability in moulding to any required form, whilst its nature is peculiarly unchangeable. As the base or chief ingredient of this compound, Mr. Chameroy employs pounded or reduced iron ore, or reduced cast-iron, or other metal difficult of fusion. Such matters are squeezed or pressed together into a solid mass, which is then soldered, so as to incorporate the particles well together, by the use of one or more metals easily fusible at low temperatures, such as tin, lead, zinc, and bismuth; and, in order to prepare this compound metal, the patentee employs a furnace fitted with a damper for the regulation of the heat at pleasure, and on this furnace is placed a cauldron, or metal receiver, to hold the materials. One part of some very fusible metal, either a mixture of lead and tin, or any other metallic compound possessing the property of fusion at low temperatures, and of tinning over or soldering a metal less easy to fuse, is now placed in this cauldron, and melted. To this molten metal is then added about four parts of the pounded iron or pounded cast-iron, steeped in a solution of ammonia or chlorine, or other preparation capable of cleansing the metal. The mass is now well mixed together, so that the particles of iron may be well tinned all over, taking care to regulate the fire, so that oxidation shall not ensue. When so treated, the mass is fit for use, and it may be poured into moulds for being shaped into a variety of articles; such, for example, as statues, columns, candelabra, fountains, and the like; as well as into cylinders, fly-wheels, pulleys, and other details, ordinarily cast in moulds. As this compound melts and cools down very rapidly, moulds composed of cast-iron, copper, or other hard metal may be used, so that the articles cast in this way may be turned out smooth and sharp, without requiring to be subsequently dressed. And as the metal is also malleable, it may be cast into plates of any required thickness, and then passed between rollers for mechanical reduction, in the manner of rolling out ordinary boiler plates. Such plates are principally intended for roofing houses, and for general covering purposes; but they may also be employed in the manufacture of tubes, tanks, and sheets for various uses. The crude metal may also be run into pigs, in the usual way, and sold in that state for the usual casting or other manufacturing purposes.

CLEANSING SEWERS AND DRAINS.

R. BLADES, *Surveyor, Liverpool*.—*Patent dated December 16, 1852.*

Mr. Blades' invention relates to the method of facilitating the removal from sewers and drains of obstructions, such as mud, silt, sand, and other solid or insoluble deposits, which cannot be readily removed by the ordinary process, commonly called "flushing." In order to facilitate this operation, in the first place, the patentee provides the sewers and drains with manways or openings, placed at certain suitable distances apart, in order, when requisite, to allow of ready access to any particular point. When it has become necessary to cleanse any part of the sewer, the manways, both above and below that part, must be opened. A small inflated bladder or float, of any suitable form or material, is then to be placed in the water at the upper opening, and floated, by means of the stream or current in the sewer or drain, down to the lower opening. This said bladder or float is attached to, and carries with it, a small line formed of Manilla grass, hemp, silk, or other suitable light substance, and thus a communication is established between the two openings or manways. By means of this line, or by means of a stronger one attached thereto, one end of a chain of suitable strength is next drawn through. This said chain is then to be passed round a pulley, and drawn upwards through the opening or manway, where it is to be attached to a "crab" winch, or other suitable lifting apparatus, which may be worked either by manual labour or mechanical power. Suitable ploughing, dredging, or excavating tools, are then to be attached to the said chain, and drawn through the sewer by means of the winch, followed by huckets, scrapers, and sweeping brushes. The mud, or other deposit, is thus loosened and carried down to the lower opening, whence it can be raised in buckets, or by any other suitable means; after which the sewer or drain may be "flushed" or cleansed with water, in the usual manner. In the event of any sewer becoming entirely obstructed, or "silted up," a communication between the two manways must be established by means of a jointed rod, constructed of cane or wire, forced through the upper stratum of the silt, which, being the last deposit, is the most penetrable portion, and a line must then be floated through, as above described; and a communication being thus established, the cleansing operations will proceed as in the former instance.

WATER PRESSURE ENGINES.

JAMES SINCLAIR, *Stirling*.—*Patent dated October 30, 1852.*

The extension of the constant supply and gravitation pressure system of water-works for large towns, has given us a new and economical means of obtaining a mechanical power suitable for a vast number of the everyday occupations of life, which have hitherto been dependent upon unaided human force. A large proportion of towns can now boast of possessing a never-failing water supply at pressures of 50 or 100 pounds per square inch. And at Stirling, a town peculiarly well circumstanced as regards the relative levels of the localities of the reservoirs and the inhabitants' houses, an average pressure equal to about 450 feet is maintained. The superior capabilities of such pressures have not been lost upon Mr. Sinclair, who has carefully worked out a simple plan of motive engine, now rapidly finding favour amongst all classes who require power for aught beyond the mere domestic concerns of life. The engines which he has already erected are of the oscillating kind, the trunnions being at the bottom of the cylinder, and answering for the ingress and egress of the actuating water, which is governed in its action by the oscillation alone. This class of engine is also available as a steam or air engine, but when used as a hydraulic machine, the working piston is composed of two disc plates, one of which has an eye to embrace the piston-rod, round which rod is put a vulcanized india-rubber ring, and over that again, one or more rings of leather. The leather rings are on the outside of the more elastic material, and the two sections of the piston being then screwed together, the end compression forces out the leather from the centre, against the interior of the cylinder.

Fig. 1 of our engravings is a side elevation of a duplex engine of this kind; and fig. 2 is a corresponding view at right angles to fig. 1, with the cylinder in section. The engine is entirely portable, being carried on the base plate, *a*, on which are bolted down the two vertical triangular frame standards, *b*, these standards having bearings, *c*, in their upper ends, to carry the main crank driving-shaft, *d*. At each projecting end of this shaft is a crank, *e*, the two cranks being set at right angles to each other on the shaft, which also carries a broad-rimmed fly wheel, *f*, from which the motive power of the engine may be taken by a band passed over it in the usual way. The plate, *a*, has also bolted down upon it the hollow valvular trunnions, *g*, which are cast with projecting base flanges for the purpose. Each trunnion is cast with two ring flanges, *h*, and the portion between these flanges is accurately turned and fitted for the oscillation thereon, of the working cylinder, *i*.

Fig. 1.

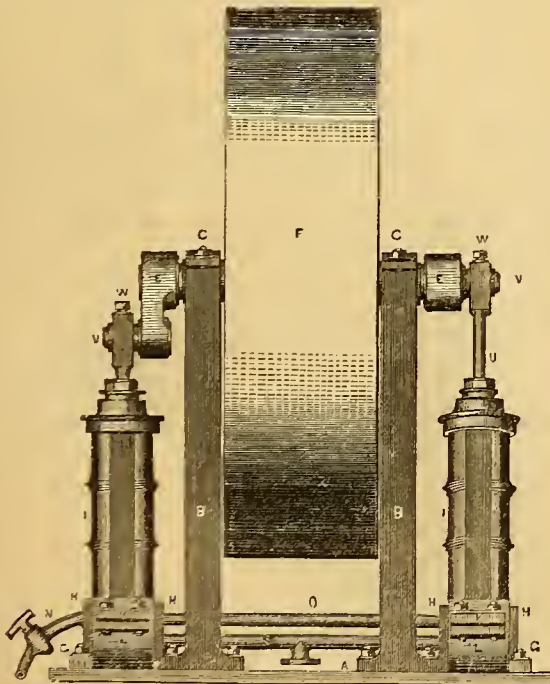

The cylinder is cast open at both ends, and its lower end is filled up by a piece of metal, *j*, screwed inside it, up to an external shoulder. This piece has side flanges, *k*, formed upon it, for bolting to similar flanges on the bottom cap, *l*. These two pieces thus form an eye to encircle

the trunnion, being fitted thereto to work fluid-tight, by being first bolted together, and then bored out to the required size of aperture. The

Fig. 2.

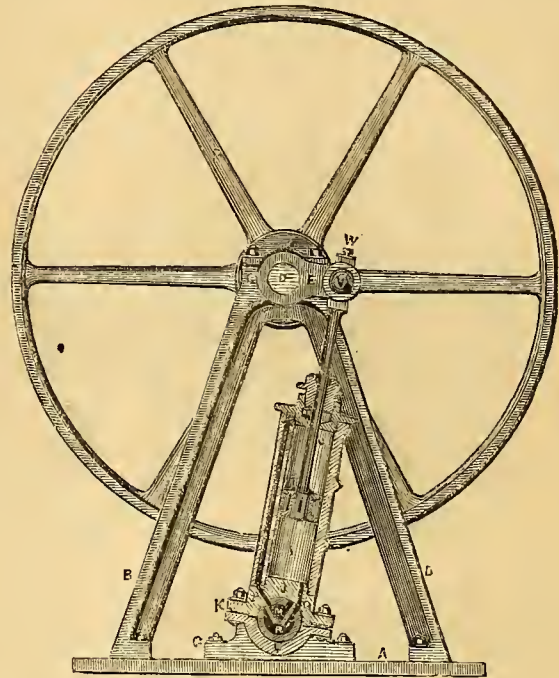

trunnion is cast with an internal angular division, forming an isolated chamber, *m*, extending from end to end of the trunnion, as an open thoroughfare in the line of the pipes, *n*, *o*, whilst it has two lateral apertures, *p*, *q*, as ingress ports from the trunnion-valve to the cylinder. These two ports correspond, when necessary, with the two ports leading to the top and bottom of the cylinder respectively. The remaining portion of the hollow in the trunnion forms a similarly continuous chamber, *r*, open at its inner end into the pipe, *s*, but closed at its opposite end by the flange-piece, *h*. As represented in the figures, one cylinder is on its dead centre, and the other, which is the one shown in section, is at its half stroke. The actuating water is supplied by the pipe, *x*, governed by a stopcock, and this conducts the water into the outer end of the chamber, *m*, in the first trunnion, and through it, and through the intermediate pipe, *o*, into the inner end of the opposite trunnion. By this means the chamber, *o*, in each trunnion, is kept constantly full of water at the working pressure, at whatever angle the cylinder may stand. In the position delineated in fig. 2, the water is passing from the chamber, *x*, into the thoroughfare leading to the upper side of the piston. At the same time the other ingress port is closed, by being brought opposite the solid portion of the piece, *j*, on the cylinder bottom, whilst the fluid, which has previously done its duty in forcing up the piston, is escaping from the lower end of the cylinder through the opposite port in the piece, *j*, and the corresponding port, *q*, in the trunnion, into the larger or exhaust division, *r*, of the trunnion, the opposite exhaust port of the trunnion being meanwhile closed, by being also brought opposite the solid portion of the piece, *j*. Then, as the exhaust passage, *r*, is open to the pipe, *s*, the waste water passes off through this pipe, and flows away at its central branch. The piston-rod, *u*, is, in each case, jointed to its crank-pin, *v*, by a solid eye, having an adjusting screw, *w*, on the top.

The engine from which our drawings were taken, has worked the printing machinery at the *Stirling Observer Office* for a very considerable time in a most satisfactory manner, both as regards smooth action and economy.

RAILWAY BRAKE.

R. HEGGIE, *Kirkcaldy*.—*Patent dated Nov. 22, 1852.*

This invention consists in a novel arrangement of railway brakes, enabling the engine driver to bring up his train almost instantaneously, by the simultaneous engagement of an entire series of brakes, one on each carriage or waggon in a train. One means of carrying out this plan is represented in the engravings.

Fig. 1 is a longitudinal section of a locomotive engine tender as fitted up with a brake apparatus. Fig. 2 is a similar section of a common waggon as an example of the plan of fitting the carriages forming the body of the trains. In fig. 1, the leading axle, *A*, of the tender has keyed upon its longitudinal centre a small eccentric, *B*, as a continuous worker, during the transit of the train. A plain rod passes back from this eccentric, beneath the tender frame, and is hinged by a common eye at *C*, to the lower end of a lever which is hung from a joint stud, *D*, in the tender frame. Nearly midway between these two joints, a catch is hinged at *E*, upon a loose stud joint in the lever, and it is further suspended by an adjusting rod, *F*, connected to its free end, and passing upwards to the engineman's foot-plate or platform above. At *G* is a central

Fig. 1.

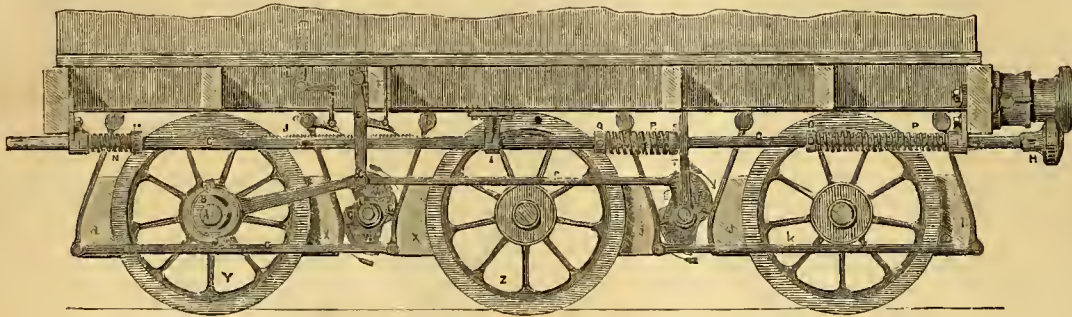

longitudinal brake rod, fitted at the hind end of the tender, with a buffer head, *H*, and carried in the bracket bearing guides, *I*, bolted to the framing. A portion of this rod is squared, and is serrated or cut with a line of ratchet teeth at *J*, on its upper side, and with these teeth the catch, *E*, is engaged or disengaged at pleasure, by lowering or raising the suspending rod, *F*, whilst immediately in front of this catch is a loose detent, *K*, jointed to a stud on the frame, and suspended by its free end from the engineman's hand lever, *L*, on the tender above. By this contrivance, when the engineman puts his hand lever, *L*, into the position shown, and lowers the suspending rod, *F*, of the catch, *E*, to the like position, the reciprocating action of the eccentric rod will gradually urge forward the rod, *G*, in the direction of the arrow, by a rapid succession of minute movements, due to the ratchet-tooth action which we have described; the rod, *G*, being prevented from returning after each stroke, by the stop action of the detent, *K*. Both the catch, *E*, and the detent, *K*, may be worked from the same adjusting lever, *L*. On the front end of the rod, *G*, is an adjustable collar, *M*, between which and the bracket, *I*, at that end, is a helix, *N*, encircling the rod, and contrived so as to prevent concussion in the rod when it is acted upon longitudinally from the train end. The opposite end of the rod, *G*, has also a similar collar, *O*, with a longer helix, *P*, abutting between it and the bracket, *I*, on that end. Near the centre of the rod, *G*, is another collar, *Q*, with a helix, *R*, abutting between it and the moveable cross-head, *S*, working against a forked lever, *T*. At *U* is a lever, fast on a short transverse shaft, *V*, set in fixed bearings in the

two sets of duplex cams, *W* & *Z*, are caused to turn partially round, and bring their prominences to bear against the backs of the blocks, *X* & *Y*, whilst the links, *E* & *F*, similarly draw their blocks, *D* & *L*, into frictional contact also. This speedily stops the train's motion; and when the frictional action is to be relieved, the engineman puts his ratchet movement out of gear, when the reaction of the spring, *P*, at once presses back the rod, *G*, and reverses the cams, which by their hooks now draw all the blocks out of action, and clear of the wheels; and if this arrangement is to be followed up throughout the train, the buffer head, *H*, of the brake-rod, *G*, is made to coincide with another rod, carried in central bearings beneath the first carriage in the train, and this rod again bears against a third rod on the next carriage, and so on throughout the train. In this way, each rod having a brake apparatus of its own, the traverse of the tender rod puts the whole series of brakes into action throughout the entire train, springs being added in each case to relieve the brakes when their action is no longer wanted.

When a collision is apprehended, the engineman puts the traverse apparatus of the rod, *G*, into action in the manner which we have described; and as the rod is thus passed forward in the direction of the arrow, it overcomes the reactive pressure of the helix, *P*, and presses through the elastic medium of the helix, *N*, upon the upper end of the forked lever, *T*, embracing the rod, *G*. The result of this is, that

the two sets of duplex cams, *W* & *Z*, are caused to turn partially round, and bring their prominences to bear against the backs of the blocks, *X* & *Y*, whilst the links, *E* & *F*, similarly draw their blocks, *D* & *L*, into frictional contact also. This speedily stops the train's motion; and when the frictional action is to be relieved, the engineman puts his ratchet movement out of gear, when the reaction of the spring, *P*, at once presses back the rod, *G*, and reverses the cams, which by their hooks now draw all the blocks out of action, and clear of the wheels; and if this arrangement is to be followed up throughout the train, the buffer head, *H*, of the brake-rod, *G*, is made to coincide with another rod, carried in central bearings beneath the first carriage in the train, and this rod again bears against a third rod on the next carriage, and so on throughout the train. In this way, each rod having a brake apparatus of its own, the traverse of the tender rod puts the whole series of brakes into action throughout the entire train, springs being added in each case to relieve the brakes when their action is no longer wanted.

Fig. 2 represents a convenient and effective arrangement of duplex brake action capable of working by pressure in both directions, and, consequently, suitable for carriages and waggons which run indifferently, either end first. The main actuating brake rod, *A*, is carried in bearings, *B*, beneath the carriage framing, at a level corresponding with all the other rods in the train, so that the buffer beads, *C*, may all work fairly together. This rod has near each end an adjustable collar, *D*, with a helix, *E*, encircling the rod, and abutting between the collar and the

Fig. 2.

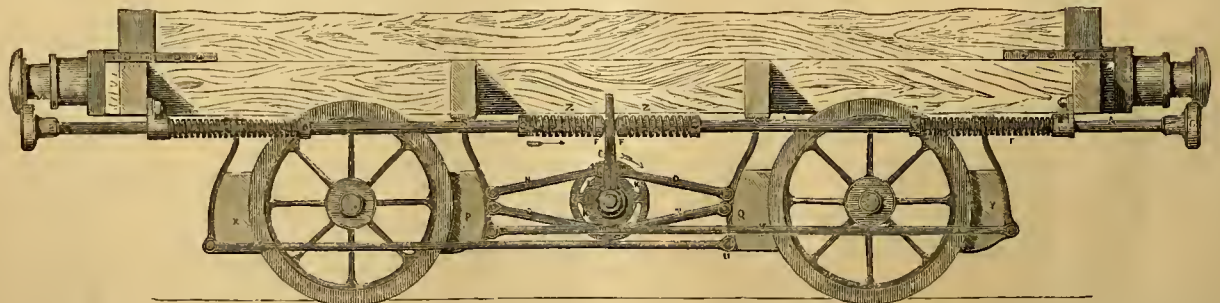

framing, and carrying at the part opposite or between the first and second wheel, on each side, a duplex cam, *W*. This cam, on each side of the tender, fits in between the external surfaces of a pair of brake blocks, *X*—one for each wheel, *Y* & *Z*. These blocks are suspended by link pieces from the stud centres, *A* & *B*, in the framing, and on the back of each is a hook, *C*, fitting to a circumferential flange on each cam, so that the back action of the cam may at once relieve them from the wheels. The front wheel,

bearing *B*, so as to give reverse spring actions to suit either direction of motion. The centre of the brake rod carries a species of duplex cross-head, *F*, embracing the upper forked end of the lever, *G*, which also embraces the rod, *A*. This lever, *G*, is fast on a central cross-shaft, carried in bearings in the wagon-framing, and having near each end of it a slotted disc, *H*, set in the line of the wagon wheels. This disc, in each case, is slotted curvilinearly, in four sections, *J*, *K*, and into each of

these slots is fitted the stud-pin, *r, m*, of the four connecting links, *n, o*, and the opposite ends of each pair, *n, o*, respectively, are jointed to eyes on the back of the brake-blocks, *p, q*. These blocks are suspended in the usual way by links hung to the framing at *s, s*; and the lower portions of the blocks carry eyes, *t, u*, for connection by the links, *v, w*, to corresponding eyes on the two outer brake-blocks, *x, y*. With this arrangement, if the actuating strain, whether arising from the mechanical brake action of fig. 1, or a casual concussion, is in the direction of the arrows on the rod, *a*, the traverse of the cross-head, *f*, which has on each side a spring-pressure helix, *z*, pushing forward the top of the lever, *g*, will put all the brakes into action through the medium of the links, *o*, of the disc, *r*. For, as this disc turns in the direction of its arrow, the ends of the slots, *k*, will press forward the studs, *m, m*, of these links; whilst, at the same time, the other studs, *l, l*, will slide freely through their slots. Similarly, when the pressure comes in the reverse direction, the relative actions of the curvilinear slots and the links will be reversed, and the brakes will be brought equally well into action, without any strain or dislocation of parts. The brakes are always brought easily and effectively into contact with their wheels, by the action of the intermediate helices, *z*, and when not intended to be down, the brakes are relieved by the helices, *e*.

TURRET CLOCKWORK.

CHARLES MILLAR, Dundee.—Patent dated December 2, 1852.

According to this invention, a jet or minute stream of water is employed for the actuation of clockwork, chimes of bells, and similar

Fig. 1.

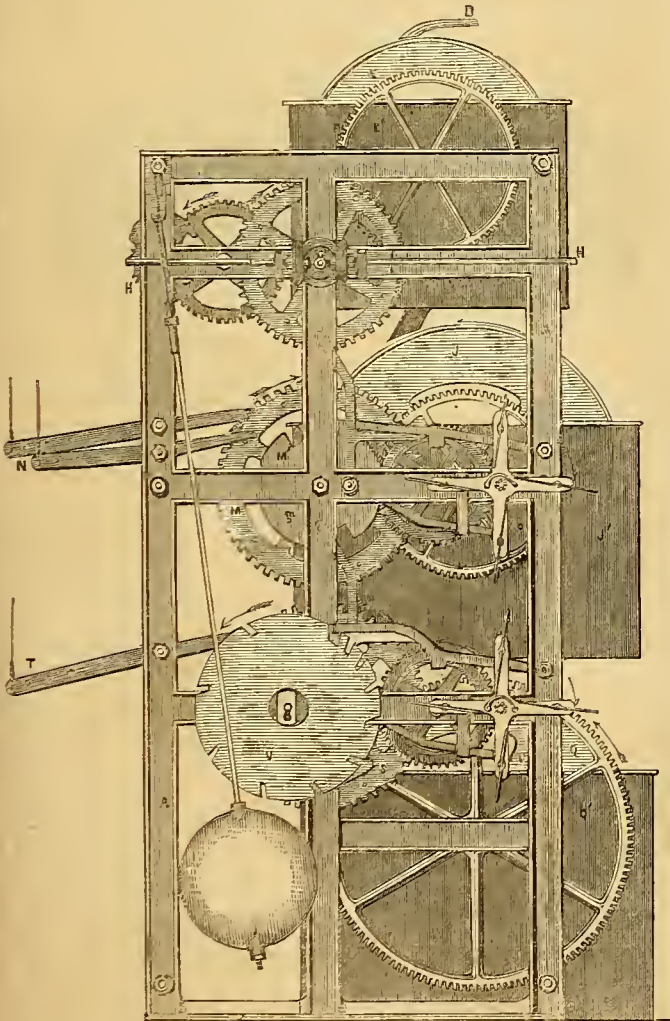

mechanism, instead of the usual weights or springs, the water being conducted upon the buckets of a small water-wheel, the shaft of which

is geared with the hour and minute hands, or connections of the clock. After leaving the first bucket-wheel, the water flows over a second but larger wheel of a similar kind, connected so as to drive the quarter department. The water thence goes to a still larger wheel in gear with the hour-ringing action. Finally, the current flows off to a cistern for use in ringing the alarm bell, as may be necessary. The bell is fixed with its mouth uppermost, and it is contrived so that two distinct tones may be obtained from it — one by striking on the lip, and the other by striking about two-thirds down the side. The arrangement for ringing the bell, or bells, at any given time, is this:—There is a disc in connection with the hour or minute spindle, so reduced in motion as to revolve once in twenty-four hours; and on the edge of this disc are wedge-shaped recesses, arranged to suit the time for ringing. In these recesses the point of a lever falls, when the disc revolves to the time required; and this lever is connected with the discharge of the cistern already referred to; so that, at the period intended, the valve is opened, and water allowed to flow from the cistern over a water-wheel connected in turn with the tilt hammers of the bells. The plug, or cistern valve, is acted on from below, and on the lip of the plug, inside the cistern, is a siphon, whose shorter leg is made to suit the intended time of bell-ringing; thus furnishing a definite time to start, and also to stop—such time being variable at pleasure. When a certain regular supply of water is not attainable at all times—as in towns—a small cistern is necessary, above the highest bucket-wheel. It is to be remarked, that this arrangement, which is applicable to the generality of turret or other clocks, is a perpetual mover, so long as it is supplied with water, and it is not necessary that the works should be as high as the dials, but they should never be lower than ten or twelve feet above the waste-water pipe of the building.

Fig. 1 of our engravings is a side elevation of the works of a turret clock arranged in this way.

Figs. 2 and 3 are an elevation and plan of the wheel-work regulating the tolling movement; and fig. 4 is a section of the cistern and valve arrangement for the same movement. Figs. 5 and 6 are a side view and plan of the water-wheel and works for the tolling movement; and fig. 7 is an elevation of the bell with its hammers. The works are chiefly contained between two cast-iron frame-pieces, *A*, whilst the actuating water-wheels are between the inner of these two frame-pieces, and a third behind. The water is brought by the pipe, *B*, from the spout of which it falls into the buckets of the uppermost water-wheel, *E*. On the shaft of this wheel is a spur-wheel, *F*, gearing with a pinion on the shaft, *G*, which is calculated to make one revolution in the hour, and reaches to one of the clock faces, whilst it communicates its motion by means of bevel-wheels to corresponding shafts, *H, H*, to the two clock faces on either side of, and at right angles to, the first; and again, another set of bevel wheels at *I* give motion to the shaft, which passes to the face opposite to the first. The shaft, *G*, is connected by a series of wheels with a pendulum escapement, in the usual manner.

The water which actuates the wheel, *E*, is caught in the cistern, *E'*, supported on the stays connecting the frames, *B* and *C*, together. From this cistern the water descends, by a suitable spout, to the second water-wheel, *J*, which actuates the movement for striking the "quarters." With the exception of the motive power and method of applying it, the arrangements here are similar to those usually adopted. A wheel, *G'*, on

Fig. 2.

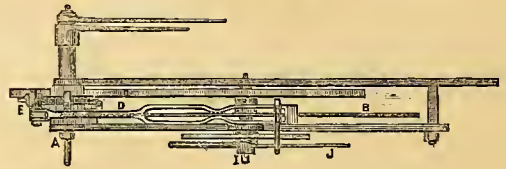
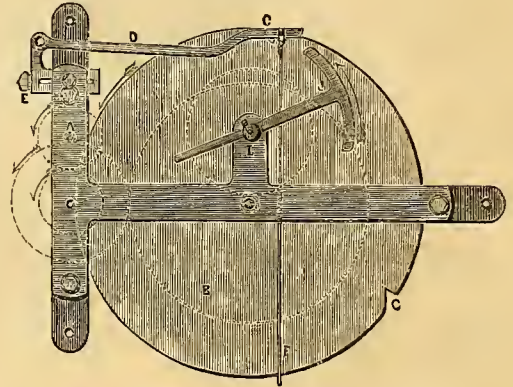
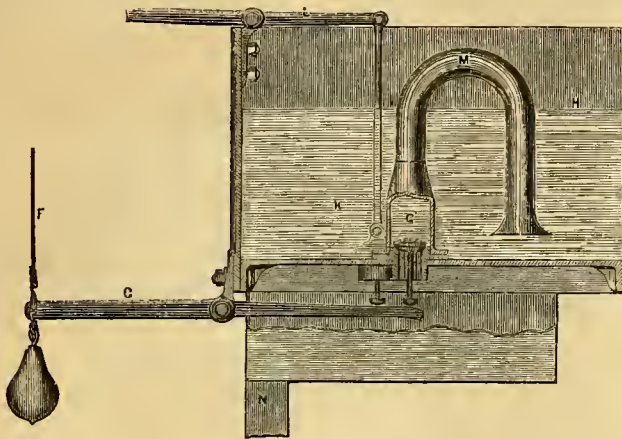

Fig. 3.

is geared with the hour and minute hands, or connections of the clock. After leaving the first bucket-wheel, the water flows over a second but larger wheel of a similar kind, connected so as to drive the quarter department. The water thence goes to a still larger wheel in gear with the hour-ringing action. Finally, the current flows off to a cistern for use in ringing the alarm bell, as may be necessary. The bell is fixed with its mouth uppermost, and it is contrived so that two distinct tones may be obtained from it — one by striking on the lip, and the other by striking about two-thirds down the side. The arrangement for ringing the bell, or bells, at any given time, is this:—There is a disc in connection with the hour or minute spindle, so reduced in motion as to revolve once in twenty-four hours; and on the edge of this disc are wedge-shaped recesses, arranged to suit the time for ringing. In these recesses the point of a lever falls, when the disc revolves to the time required; and this lever is connected with the discharge of the cistern already referred to; so that, at the period intended, the valve is opened, and water allowed to flow from the cistern over a water-wheel connected in turn with the tilt hammers of the bells. The plug, or cistern valve, is acted on from below, and on the lip of the plug, inside the cistern, is a siphon, whose shorter leg is made to suit the intended time of bell-ringing; thus furnishing a definite time to start, and also to stop—such time being variable at pleasure. When a certain regular supply of water is not attainable at all times—as in towns—a small cistern is necessary, above the highest bucket-wheel. It is to be remarked, that this arrangement, which is applicable to the generality of turret or other clocks, is a perpetual mover, so long as it is supplied with water, and it is not necessary that the works should be as high as the dials, but they should never be lower than ten or twelve feet above the waste-water pipe of the building.

the shaft, *g*, which makes one revolution per hour, has four equidistant pins upon it, which, in succession, acting upon the lever, *k*, release the wheels below. Then the water which, during the previous quarter of an hour, has been accumulating from the cistern, *e'*, above, in the buckets of the second water-wheel, *j*, turns it, and also the spur-wheel, *m*, by

Fig. 4.



means of the spur-wheel, *l*, on the shaft of the former, and a pinion on the shaft of the latter. The spur-wheel, *m*, has pins on each side to actuate the levers, *n*, these last communicating by means of wires with the two bell-hammers, giving the well-known double stroke indicating the "quarters." The shaft of the spur-wheel, *m*, carries the usual notched disc, *m'*, for regulating the number of strokes, whilst the spur-wheel, *m*, also actuates the usual vane-wheel, *o*, for making the motion uniform. The notched disc carries a single pin, *m*, which, at every fourth quarter, acting on the lever, *p*, releases the lowest set of wheels, comprising the hour-striking movement. The water from the wheel, *j*, is collected in the cistern, *j'*. It descends from this by a spout, and falls upon the lowest water-wheel, *q*, accumulating in the buckets during the intervals between striking, until the lever, *p*, releases the wheels, which are set in motion by the large spur-wheel, *n*, on the shaft of the water-wheel, *q*, driving a pinion on the shaft of the spur-wheel, *s*. The latter carries pins

Fig. 5.

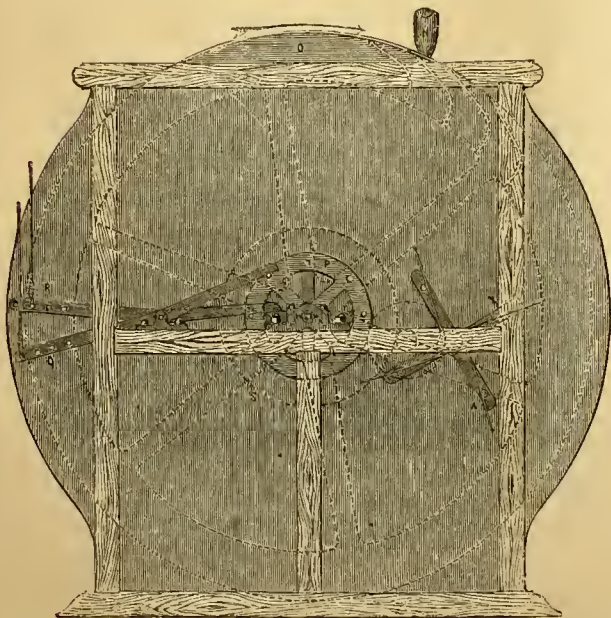

for actuating the lever, *t*, communicating with the hammer which strikes the hours. By means of an intermediate pinion and spur-wheel, the spur-wheel, *s*, drives the fan-wheel, *v*, and also actuates, in the usual manner, the notched disc, *v*, for regulating the number of strokes for each hour.

The water from the wheel, *q*, is collected in the cistern, *q'*, and passes thence by a spout to the cistern for supplying the water to the tolling movement. This movement is more especially intended for periodical tolling; as, for example, at half-past five o'clock each morning, and at ten o'clock each evening. It is regulated in the following manner:—The shaft, *a*, which is one of the four shafts carrying the hour hands, and corresponding, for example, to the shaft, *g*, in fig. 1, is so geared with the shaft of the large disc, *b*, as to cause this to make one revolution in the twenty-four hours. The disc, *b*, has notches, *c*, situated on its periphery, to correspond with the times at which the tolling is intended to take place. The frame which contains this portion of the wheel-work, as also that for driving the motion of the minute-hand from that of the hour-hand shaft, *A*, represented as immediately behind the clock face, carries a vibrating lever, *d*, capable of a slight adjustment by means of the thumb-screw, *e*. The free end of this lever, which is forked, has a cross-piece which falls into the notch, *c*, on the disc, when this comes under it, and it also communicates by the cord or wire, *f*, with the valve lever, *e*, of the cistern below. The lever, *e*, has a weight hung to the end, to which the wire is attached, so that when, by reason of the notch, *c*, on the disc, *b*, coming under the end of the lever, *d*, this descends, and the cord or wire is slackened, the weight brings down the lever, *e*, and raises the valve, *e'*, which gives egress to the water in the cistern, *u*. To the lip of the valve, *e'*, is attached a siphon, *m*, the object of which is to equalize the flow of the water, and to make the tolling stop at once when the level of the water gets below the mouth of the siphon, and without the risk of any chance stroke taking place from the accumulation of small quantities of water from leakage, since the water cannot again obtain egress from the cistern until its level has reached the top of the siphon. To prevent the tolling from taking place on Sundays, a small pinion on the shaft of the disc, *b*, drives a spur-wheel on the stud centre, *i*, calculated to

Fig. 6.

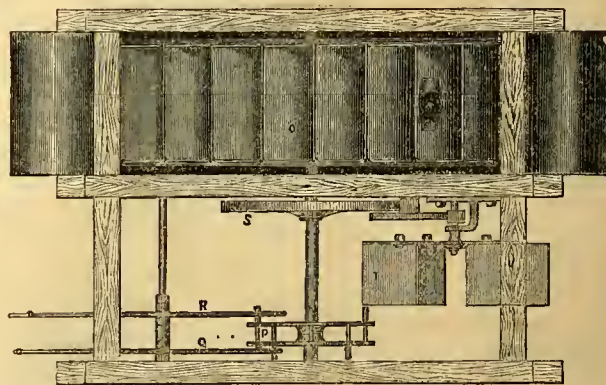

make one revolution per week; to the boss of this spur-wheel is fixed a small balanced lever with a segmental end, *j*, so set as to come under a pin on the end of the lever, *d*, on the Sundays, and keep the end of the lever from falling into the notches, *c*, of the disc, *b*, and thereby preventing the tolling of the bells. An additional arrangement is also provided for setting the tolling movement in action when required, as before the church service, for instance, and on any extraordinary occasion. For this purpose the cistern, *u'*, is provided with a second valve, *k*, which can be opened by hand from below by a cord or wire, or by the clock itself, if required. The valves, *e'* and *k*, open into the upper enlarged part of the pipe, *x*, which conveys the water to the wheel, *o*, for actuating the tolling movement. The arrangements here are similar to those already described; the shaft of the water-wheel, *o*, has fixed on it a double disc-wheel, *r*, carrying eight pins, four of which project on each side to raise the ends of the levers, *q*, *n*, to the opposite ends of which are attached wires communicating with the tolling hammers. The shaft of the water-wheel, *o*, also carries a large spur-wheel, *s*, which actuates the fan-wheel, *t*, by means of an intermediate pinion and spur-wheel. The bell, *u*, is kept stationary, instead of being moveable, as is generally the case. It is firmly attached to a cross beam, *v*, in the steeple, and has its mouth uppermost. The object of the first of these arrangements is to do away with the excessive vibration caused by the motion of the heavy mass of metal in the ordinary system, as also to reduce the amount of power required; and the object of inverting the bell is to enable the sound to be heard to a greater distance. The hammers to give the "quarter" strokes are at *w* and *x*, and are actuated

by the levers represented at x, in fig. 1; the first hammer striking the bell at the lip, and the second striking it considerably lower down, by which means two very different sounds are obtained. The hammer, x, is for striking the hours, and is actuated by the lever, r, in fig. 1, and the hammers, z, z, are for tolling, and are actuated by the levers, q, r, in figs. 4 and 5. The first is situated at the lip, and the second lower down, and is necessarily much heavier than the other. Each hammer is hung in suitable bearings, so as to remain well clear of the bell by its own weight, and in striking is first tilted up away from the bell, and when the cord which does this is let go, the hammer falls against the bell by its own weight, and then resumes its original position. By these

Fig. 7.

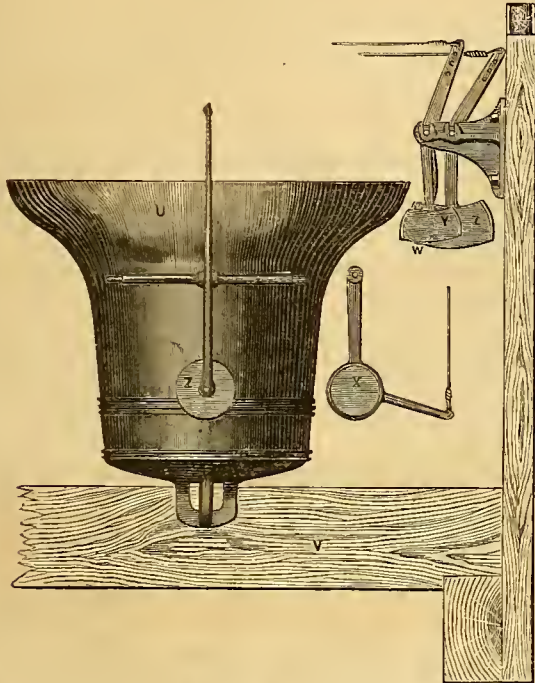

means much less power is required to give the stroke, even though the hammers are more than double the weight of those commonly used, whilst the sound elicited is much clearer and fuller than that produced by the ordinary appliances.

RAILWAYS.

HUGH GREAVES, *Civil Engineer, Manchester.*—*Patent dated Nov. 13, 1852.*

Mr. Greaves, whose "Iron Surface-packed Sleepers" we some time ago noticed,* as prominent objects in the Great Exhibition of 1851, brings forward four different heads of improvement under this patent:—A mode of forming firm end junctions of the rails; a new joint chair; a rail to be used on inclines, or situations where great wear occurs; and a new crossing support.

Fig. 1 represents a side elevation of the new mode of supporting and fastening the bridge rail at the joints, and fig. 2 is a corresponding trans-

Fig. 1.

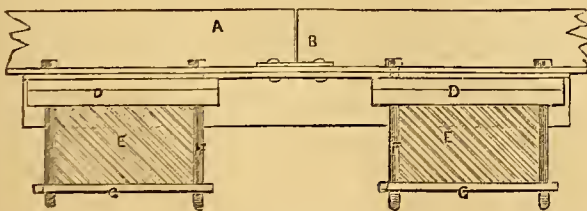

verse section of the same: A are the bridge rails, which are bolted or riveted at B, to the wrought-iron supporting girder, C. This girder rests

at its extremities on the chocks of wood, n, and is firmly secured to the transverse sleepers, E, by the bolts, F, which are screwed at their lower ends into the metal plates, G, beneath. The supporting girders may consist merely of an inverted bridge rail, and the internal space between the rail and girder may be filled with wood, to deaden the sound and render the junction more firm.

Fig. 3 is an elevation of another mode of supporting bridge rails at the joints to prevent their lipping. In this arrangement, the joint is placed immediately over the transverse sleeper, A, which is recessed at its upper surface to receive the supporting girder, B. The rails, C, are riveted, or otherwise secured, by their flanges to the supporting girder,

Fig. 2.

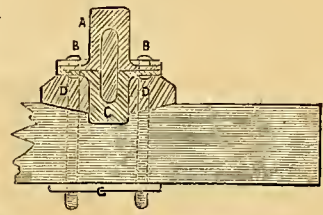
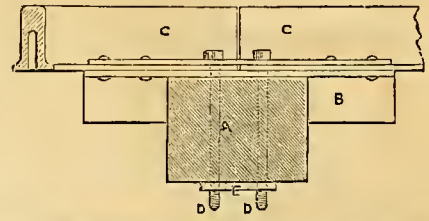
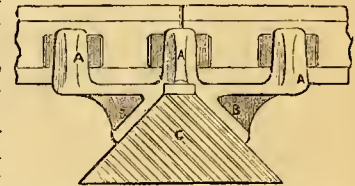

Fig. 3.



and the whole is firmly secured to the sleeper by the bolts, D, which pass through the sleepers, and are screwed into the metal plates, E, beneath them. Fig. 4 is a side elevation of a compound joint chair, formed of three chairs, A, cast in one piece, the base, or bearing surface,

Fig. 4.



B, being cast at an angle, to fit the angular sleeper, C. The centre portion of this compound chair coincides with the joint of the rail. Pins or screw-bolts may be employed for securing the chairs to the sleeper. By this means, a better hold is obtained on the ends of the rails, which are, consequently, held more securely, and a good and firm joint is thereby formed. Fig. 5 is a transverse section of a rail, showing the mode of securing and supporting it at the junctions. The ends of the rails, A, are supported by the sleeper chair, which is composed of wrought and cast-iron combined. B is a curved

plate of malleable iron, formed with three openings in the centre to admit three chairs, which are cast on the girder. Lugs or bars, F, are cast upon the girder, and overlap at their extremities the edges of the curved plate, thereby preventing it from spreading when supporting a heavy load. The chairs are introduced through the openings in the plate from the under side, and the rails are then inserted into the chairs, and secured therein by keys or wedges, in the ordinary manner. Fig. 6 is a transverse section of a portion of a permanent way, and shows the improvements in the employment of wood for railway sleepers. By this arrangement, instead of employing one block of wood, running across from one rail to another, Mr. Greaves uses two separate short sleepers, A—the gauge and tilt of the rails being preserved by the tie-bars, B. The rails are supported at the joints on a girder of wrought-iron, or a piece of rail, C. The chairs may be cast in one piece with the supporting girders, C, or otherwise secured to them; and two chairs may be employed at the joint, so that, when one key is backed to take out the rail, the other one will remain undisturbed. The girder or piece of rail may rest at the ends on two loose chairs.

Fig. 5.

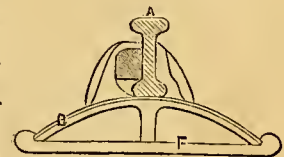
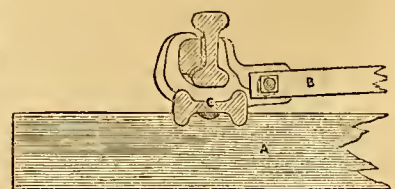

Fig. 6.



The patentee also shows sections of two shallow bridge or flat-hot-tomed rails, riveted together at their flanges, the internal space being filled with wood, to deaden the sound and take off the lateral strain from the rivets. A portion of this space may be employed for the insertion

* Page 84, Vol. IV., *Practical Mechanic's Journal.*

are so arranged, that their respective junctions shall not coincide—that is to say, that the junctions of the lower set of rails are overlapped by the upper rails, and *vice versa*.

Fig. 7 represents a transverse section of two rails joined longitudinally, and fastened together in the chairs. A piece of metal, *A*, is inserted at the joints, through which bolts or rivets are passed, to prevent vertical displacement. This description of rail is particularly applicable for stations, or on inclines, and other places, so as to economise the wear and tear of the tyres of the rolling stock, by bringing into action the outer portion of the tyre, *c*, and thereby saving the travelling portion, *d*, at those places where the tyres are exposed to the heaviest work; or, in place of two rails, one broad rail may be employed. The respective joints of these double rails are overlapped by the rails themselves. In securing the rails at the points or crossings, the rails are held by chairs, which are carried by transverse rails. These rails may be carried by surface-packed sleepers, and may be of the bridge

section, the space inside serving as a receptacle for the connecting-rods for working the points.

Fig. 7.

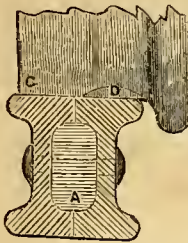

WEFT WINDING MACHINE.

PETER CARMICHAEL, *Dundee*.—*Patent dated November 19, 1852.*

Mr. Carmichael's invention embraces three several heads:—A variable spindle movement for securing the uniform velocity of the yarn, and the balancing the power required for driving the machinery; a means of giving a variable movement to the guides for laying on the yarn on the

Fig. 1.

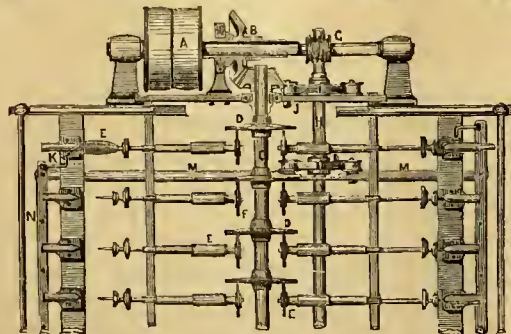
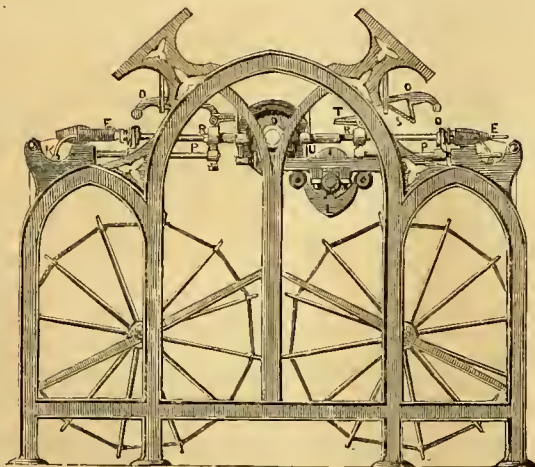

Fig. 2.

pirns; and the application of a lever for regulating the hardness of the winding, and for stopping the spindles when full. The pirns or cops being usually filled with yarn by conical winding, an important element of irregularity of speed in the hank or bobbin from which the yarn is wound is here introduced. Hence a series of tugs or pulls are given to the yarn as it passes from the small to the large end of the cone; and, at the same time, the yarn is huilt too soft upon the small end of the cone, rendering it very liable to slip off, and cause waste and bad work in

weaving. These evils Mr. Carmichael very ingeniously removes, by means of the mechanism which we have engraved. Fig. 1 is an end elevation of his improved winding machine. Fig. 2 is a partial plan corresponding. The machine is actuated by the fast and loose pulleys, *A*, and from their shaft motion is communicated through the pair of bevel wheels, *B*, to the longitudinal shaft, *C*, running the whole length of the machine, and carrying the series of disc plates, *D*. The spindles, with their pirns, *E*, are driven by pulleys or washers of leather, *F*, kept true, and stiffened by iron washers, one on each side of the leather, and these drivers, with their spindles, receive their revolving motion by contact with the disc plates, *D*. The spindles, *E*, are made in two parts: the part on which the driver is fixed has only the revolving motion, and is made hollow; the other part has also the revolving motion, and is made to slide back into the hollow, being driven by a key sliding in a groove.

Next, to effect the variable motion of the spindles upon the cross shaft is a spiral, *G*, giving motion, by a spiral wheel, to the shaft, *H*, upon which are fixed hearts or cams, *I*, giving a uniform traversing speed to the carriers or sliding hars, *J*, which bars carry the shaft, *C*, and disc plates, *D*, and, at the same time, move the bevel wheel, *B*, through the same space on the cross shaft, keeping it always in gear with its pinion. By this traversing motion of the disc plates, the large and small diameters of which correspond proportionally with the large and small diameters of the cone of the pirn, the velocity of the pirn, or spindle, alternately increases and diminishes, and the power is, at the same time, balanced; for when the large diameter of the disc is driving the one spindle, the small diameter is driving the opposite one, and so on alternately.

The next point to be described is the finger or guide, *K*, which feeds or guides the thread, and lays it evenly on the pirn. This guide has to travel the exact distance of the length of the cone on the pirn, and it has also to travel quicker or slower as the motion of the spindle is quicker or slower. This is effected by a peculiar-shaped heart or cam on the shaft, *H*, shown at *L*; this heart gives a suitable traverse motion to the bars, *J*, on which are fixed the longitudinal bars, *X*, carrying the fingers, *K*.

The remaining point to be described is that of the levers, *O*, for regulating the hardness of the laying on of the yarn, and also for stopping the spindles when the pirns are full. They are attached to the spindles by sliding-rods, *R*, moving parallel with the spindles, and connected to them by the forked ends, *Q*, of upright studs, embracing collars upon the spindles. The levers are jointed upon the studs, *R*. As the pirn fills, the spindles and levers are pushed back by the filling on of the yarn, and the inclined plane upon the lever, seen at *S*, is made of such a shape as the resistance of its rising up the incline shall just give the requisite hardness to the laying on of the yarn on the pirn, which is a very essential point. When the pirn is full, it has pushed back the lever, *O*, to the extreme end of the inclined plane, when the lever drops and brings a projecting point, *T*, in contact with a wedge attached to the top of the stud, *U*, which carries the spindle-driver, and removes the driver from contact with the disc plates, *D*, and then the spindle stops.

The mode of operation is as follows:—An empty pirn being attached to the end of the thread by the attendant, she then lays hold of the lever, *O*, and pulls it forward along with the spindle, until a cross thread on the end of the spindle comes into a notch for it in the head of the pirn, when the pirn is set in motion, and goes on without farther attention until it is full, when the lever drops, and the spindle stops. The attendant then removes the full pirn, and replaces it with an empty one, and so on.

BISCUIT OVENS.

WILLIAM SLATER, *Carlisle*.—*Patent dated Dec. 1, 1852.*

Carlisle, the great seat of the biscuit manufacture, has here furnished us with a most important improvement in the apparatus for baking. This contrivance, which is now in full operation at the extensive biscuit works of Mr. Slater, has been devised for baking all articles of this class, as well as bread, and even earthenware, by traversing them through a heated earthenware tube. This tube forms the oven; it is of considerable length; and the biscuits or other articles are slowly traversed through it, from end to end, at such a rate as will allow of the baking being completed during the passage. The biscuits are carried on trays, set on travelling chains; or the trays may be made into an endless web or chain. The oven is thus entirely self-acting, and the baking articles demand no attention whatever from the attendants, whilst the system involves superior economy and better baking. A pyrometer, or heat indicator, is also attached externally, so that the attendant can regulate the heat with very great facility.

The object of such improvements is to reduce the cost of baking, and to improve the appearance of the baked articles; and the apparatus is applicable as well to the baking of clay, or earthenware articles, as to bread or biscuits.

Fig. 1 of our engravings is a longitudinal section of the oven, as more especially contrived for baking biscuits; and fig. 2 is a transverse section. The earthenware haking tube or retort, *a*, which is the actual baking chamber, is shaped somewhat like a gas retort, and is of considerable length—from sixteen to twenty-four feet being the length which Mr. Slater finds convenient and effective. This tube is set in brickwork, like a steam boiler, and it is heated by the furnace, *b*, which is supplied with fuel in the usual way. The direct radiant heat of the fuel is received by the overhead brick or clay arch, *d*, and the heat and gases pass off from the grate along the bottom flue, *c*, in the direction of the arrow, running hence along beneath the tube, *a*. At *e* are side or lateral passages, branching off, from the furnace and main bottom flue, into the side and overhead flues, *f g*, between the outside of the clay tube, *a*, and the interior of its surrounding mass of brickwork, so that the tube, *a*, is thus completely enveloped in a heated medium. After traversing all the flue lengths, the heated current finally passes off through the chimney, *h*. The haking tube is open from end to end, and is covered in at these entrances by iron plates, *i*, slotted through, to admit the endless carrying band or chain, *j*, to pass through. This band or chain is carried upon two external rollers or pulleys, *k*, set at the required level outside the tube, *a*, both the upper and lower lengths of the chain being passed right through the whole length of the tube, and supported therein by an upper and lower line of bearing rollers, *l*. This carrying chain may be formed in various ways. It may either be composed of two parallel endless chains, with carrying trays laid across, or of a series of trays so connected as to form an endless chain; or an endless web of wirecloth may answer the same purpose. One of the pulleys, *k*, being made to revolve at the required rate, by means of any convenient prime mover, the chain with the biscuits, or articles to be baked, laid on, is traversed through the tube, the unbaked articles being deposited upon the chain at one end, and carried directly through and out at the other, the speed of movement being proportioned, so that the articles shall be baked to the required extent in the transit. The baking heat is of course derived from all sides of the heated tube, *a*; and this heating power is capable of nice regulation, by means of dampers, suitably disposed in the flues. The pyrometer, or heat indicator, consists of a copper rod, *m*, stretched along the upper side of the

again marked as before, the rest of the gradations being marked in the usual manner of marking thermometric scales.

POWER-LOOM WEFT FORKS.

TAYLER AND SLATER.—*Patent dated October, 23, 1852.*

These improvements in a well-known little instrument, are designed to lessen its liability to fracture; to render it more easy of repair in case of accidental injury; and to improve its working qualities. With these views, the patentees make the stock or detent lever, *a*, of their improved fork (represented in profile in fig. 1, and in plan in fig. 2) of annealed malleable-iron, in a separate piece from the prongs or fingers, *r r r*. The latter are of steel wire, tapered towards the points, and polished so that their surfaces present no roughness to which the loose filaments of the weft may adhere. These prongs are inserted in holes drilled in the stock for their reception, and riveted so that a broken prong can be easily removed and replaced by a new one.

Fig. 1.

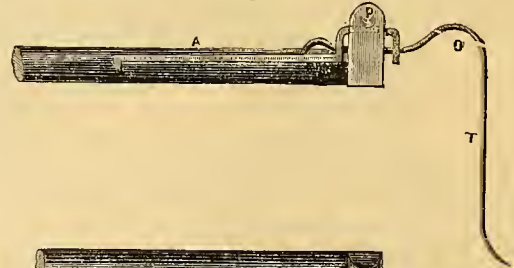
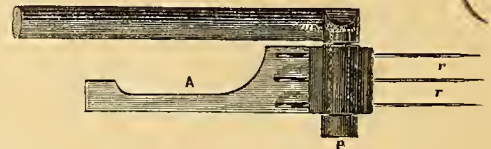

Fig. 2.



The pivot, *p*, on which the fork is suspended in the stand is placed rather higher than usual, relatively to the other parts of the apparatus, so that the centre of gravity of the whole being further removed from the point of suspension, the stability of its equilibrium is increased, and it more readily regains and retains its position after disturbance. By this means the resilient or dancing motion of the fork, so embarrassing where looms are run at a high speed, is obviated.

Instead of the prongs being turned downwards suddenly, so as to make nearly a right angle, which form renders forks of the ordinary construction peculiarly weak and liable to fracture at that point, they are brought round to the vertical direction by a slow curvature, forming a sort of bow, as at *o*, which renders them as strong at that point as in any other part.

The wire which serves as the pivot on which the fork is suspended in the stand is not secured by being riveted at its ends, but is retained in its place by a small pin, *m*, which is inserted at right angles to the pivot wire, in such a manner as to pass partly into the side of it. The bead of the pin, *m*, is left slightly projecting, so as to allow it to be easily withdrawn by the aid of a pair of pliers, when the fork can be at once removed from the stand for the purpose of being repaired, or cleaned from accumulated dirt or fly.

Notwithstanding these advantages, the facility and cheapness of its construction are such as to entail no augmentation of the usual cost.

REGISTERED DESIGN.

UNIVERSAL SAFEGUARD FOR CLEANING WINDOWS.

Registered for Mr. W. DUCKWORTH, Architect, Liverpool.

This is a little contrivance for safely supporting servants when cleaning the external sides of windows. Fig. 1 is a transverse vertical section of the safeguard as applied to a window, and fig. 2 is a corresponding plan. It consists of an iron, *a*, bent frame, round, and ter-

Fig. 1.

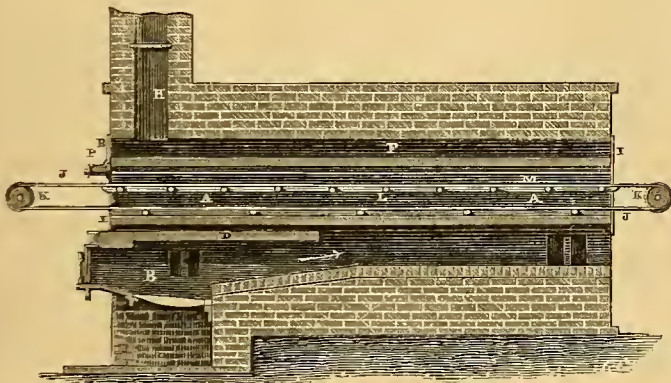
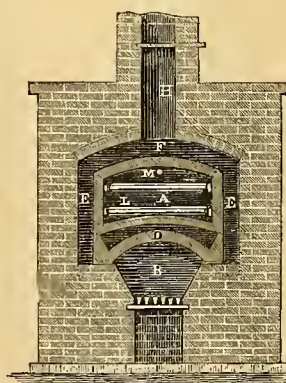

Fig. 2.



tube. It is fixed at the back end, but its other end is loose, and passes freely through the plate, *i*, at that end. Here it is connected to a stout helical spring, contained in the box, *r*, and contrived so as to hold the rod, *m*, in a high state of tension, the spring being protected from the heat of the box, which is lined with loam or sand, or is made of baked wood. The end of the rod has a transverse pin attached to it, and this pin works through a longitudinal slot in the box, being made to act upon an arrangement of multiplying levers, terminating in an index-hand, *n*, pointing to the degrees of temperature, marked upon the outside of the plate, *i*. In this way the expansion and contraction of the rod, *m*, points out the variations in the temperature, by the corresponding movements of the hand over its indicating scale. To support the rod, *m*, pendant links are either hung from the roof of the oven, or two other metal rods are passed through the oven, a few inches apart, in a parallel line, such rods having a series of cross bearers at intervals, capable of movement upon the longitudinal rods. The latter are fixed by one end, and moveable at the other, like the rod, *m*. In marking the heat gradations on the scale, the details are first set up, and the position of the index-hand is then marked off while the oven is cold, the temperature of the oven being taken by a thermometer. This is the zero of the indicator. The heat is then brought up, and the temperature is

minating in screwed portions, b, which are passed through the open space of the window into the house, support being derived from the two inclined stays, c, abutting by their lower ends against the exterior of the house wall, d. Each end, b, has a sliding-piece, e, passed upon it, as an inside retaining abutment, and these slides are ad-

Fig. 1.

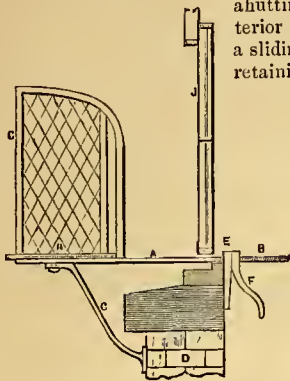

justed as holding-pieces, by the nut levers, f. By screwing up these levers, f, the frame is securely held against the wall, and a wire-work guard-frame, c, being set on the top of the frame platform, n, the operator is securely held whilst he cleans the window, j.

Fig. 2.

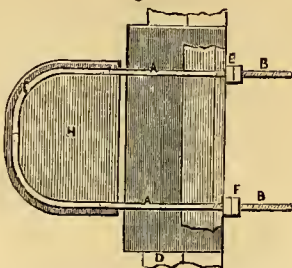

EOLIAN HAT.

Registered for MESSRS. FLANAGAN & CO., York Chambers, Liverpool.

The rather fantastic name, "Eolian Hat," has been given to the new design of which our engravings, figs. 1 and 2, respectively show an external elevation and vertical section. The object is to fit the hat more comfortably to the head, by forming a soft rim in it where the head enters.

Fig. 1.

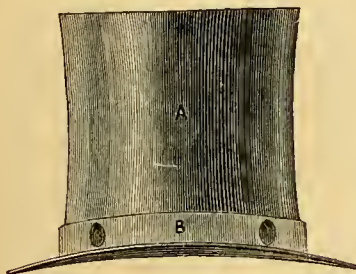

The body, A, of the hat is unaltered, except that it is moulded with an external annular air-channel, b, standing up a short distance above the brim. In other terms, the mouth of the hat is made a little wider or larger than is usual, and this channel answers as a receptacle for air, to act as an elastic fitting cushion. This recess may be partially filled with cork shavings, or other light material, or it may contain air alone. It is covered in, airtight on the inner side, by a flexible hand, c, glued down to the body, an opening being left to the external air.

Fig. 2.

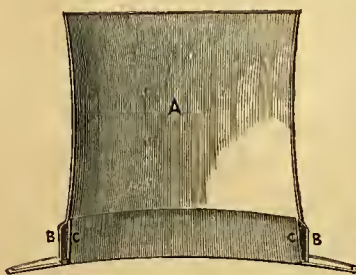

In this way, a completely encircling air-chamber is formed to embrace the head, and make an easy, pleasant fit; all that appears externally is the hand-like projection which contains the elastic fitting piece.

REVIEWS OF NEW BOOKS.

A FEW REMARKS ON THE PRESENT STATE AND PROSPECTS OF ELECTRICAL ILLUMINATION. By Joseph J. W. Watson. 8vo. Pp. 32. London: Saunders & Stanford. 1853.

Gaily decked out in red and pink, with the revived antique thick covers, and sprinkled over with red initial words to its paragraphs, this handsome little hook tells an interesting story under a most attractive guise. In addition to the title recorded above, the frontispiece goes on to say, "with a Description of the Author's Patented Inventions in Galvanic Batteries and Electric Lamps." As far as the actual lamp is concerned, we have already discharged our office, in respect to Dr. Watson's productions, in our engraving and description of his very suc-

cessful lamp, given in our June part; but we have yet to follow the author for awhile in his detail of the earlier stages of the improvements, and the actual results arrived at in the other ramifications of the plans.

In all galvanic arrangements hitherto existing, the gain to the operator is electricity, and nothing more. The solid working products are valueless. But Dr. Watson—with whom, we ought to remark, was at this time associated Mr. Thomas Slater, an ingenious mechanician and inventor in the same pursuits—set himself the task of extending the galvanic scale, and obtaining electricity from untried sources, with the view of producing matters which should be commercially valuable, in addition to the essential product of electricity. This attempt failed, and it was then determined on to try the effect of new exciting agents, or "electrolytes," and the result was the opinion that, "if we have not accomplished all, we have at least made such strides towards improvement, that the commercial world need not now fear the introduction of an old natural force in a new and useful dress of art."

The new battery has received the name of "chromatic." It is a colour-maker, and by the introduction of no more than five substances, it produces "a hundred valuable pigments, transcending, by a great per centage, the original value of the articles contributing towards their production." These colours are not compounded of the working products; they are developed in the actual generation of electricity, whilst the employed substances act peculiarly in giving "constancy" of effect.

It is the Maynooth battery which is employed, and its value as an electric light-maker is improved in this way:—

"Prussiate of potash, or, as it is known to chemists, ferrocyanide of potassium, gives with the salts of iron a most splendid blue pigment—Prussian blue, which, when pure, is of the greatest value. In the Maynooth battery we employ the prussiate of potash thus:—To the iron cell we add prussiate of potash, and to the zinc cell also the same salt, although we restrict the quantity greatly, for reasons which need not be described here, but which, to those having any acquaintance with the nature of galvanic arrangements, will be at once apparent. Our products are Prussian blue, of a quality and colour equal, and, as we have been disinterestedly informed by those dealing in the article, far superior to any in the market. Our other product is a peculiar blue pigment, of a colour resembling and closely vying with the artificial ultramarines. This pigment, from its chemical constitution, as proved by our analyses, we have termed the ferropussiate of zinc."

Mr. Callan's modification of Smee's battery is also employed, and the colour products are in this case chrome-yellows, the result of the addition of dichromate of potash, the depth and tint of the pigments being varied with the proportion of the added salt:—

"This platinized lead battery is about 15 times as powerful as a common Wollaston battery of the same size. A cast-iron battery is a little less powerful than the platinized lead one, but it is cheaper in its first erection, since the iron plates do not require to be platinized. Three platinized lead batteries, excited by a solution of nitre and sulphuric acid, or three cast-iron batteries excited by nitrous and sulphuric acid, will afford the most brilliant light, equal, at least, to 300 wax candles; whilst it requires 160 cells of Daniel's constant battery, or 250 of the ordinary Wollaston battery, to effect the same object. Three of the lead or iron batteries will occupy just one-sixth the space occupied by Daniel's arrangement, and one-twelfth of what is occupied by Wollaston's."

A splendid blue pigment—resembling the better description of "smalts"—is also made in a new arrangement of the Wollaston battery, by adding prussiate of potash. Then, as prussiate of potash gives a blue colour with iron, and chromate of potash a yellow colour with zinc, it follows that, if these salts are added in a battery of iron and zinc, the colour produced will be a green. And by adding prussiate of potash to the lead battery, a white pigment of great body is made, and this will not blacken when exposed to sulphuretted hydrogen. If chromate of potash alone is added to the iron battery, a deep brown is made; and if lime is added with chromate of potash to the lead battery, a brilliant red of good body results. The working fumes are also turned to account, nitrate of potash and sulphuric acid being made out of them.

A "postscript," which the author has introduced in a second edition of his hook—the cover of which, by the way, appears to have been deeply hued by the contents of one of the batteries—is devoted to a consideration of "costless electricity." Here he discusses the operation of the battery in electrolytising, as well as in desulphurising coke on the patented principle of Mr. Church of the Phoenix Gas Works, a process hitherto unpractised from want of a cheap power.

A solution of common salt, decomposed in the battery, produces a highly innocuous bleaching liquid—hypochlorite of soda; or the chlorine may be separated and absorbed by water, caustic soda remaining in the vessel in which the salt was decomposed. Common salt is obtainable at £1 a ton, and caustic soda and chlorine are respectively worth £12 and £15 a ton. Fifty tons of salt, when decomposed by the battery, furnish thirty-two tons of soda and thirty-six tons of chlorine; hence salt costing £50 is transmuted into matter producing £920.

Dr. Watson winds up his remarks with some general notes on galvanic power as a motor, but of this more may be said hereafter. As regards the conveyance of electricity to ranges of lamps, we are told that "an electric main, a quarter of an inch in diameter, will convey as much light-affording material as a six-inch gas main."

The only drawbacks to the perusal of this very interesting volume, are certain obscurities of phraseology, and occasional crudities of expression. If our readers will push resolutely through these difficulties, they will find Dr. Watson a valuable guide, where a guide is really needed.

STRUCTURES ON THE CONDUCT OF THE POLICE COMMITTEE AND THE INSPECTOR OF SMOKE NUISANCE: being a Letter addressed to Robert Stewart, Esq. of Omoa, Lord Provost of Glasgow, by One of Four Hundred. Glasgow: J. M'Leod, 1852. Pp. 15.

Nebuchadnezzar dreamed dreams wherewith his spirit was troubled; and he called upon the wise men, not only to interpret the dreams, but to discover what they were, saying, "The thing is gone from me; if ye will not make known unto me the dream, with the interpretation thereof, ye shall be cut in pieces."

A dream has been dreamt, in more modern days, of clear skies, untainted with the fumes of power-giving coal; and, with a despotism somewhat parallel, has the interpretation, or realization thereof, been demanded. The writer of the local pamphlet before us, however, does not profess to be the Daniel in this case, but, as the mouthpiece of the "wise men," remonstrates with the modern Nebuchadnezzars on the unreasonableness of their demands.

Manufacturers are told to consume their smoke, whilst, as yet, the consumption of smoke is a problem unsolved. Our Four Hundredth man is by no means desirous of continuing the nuisance, if it can be avoided by reasonable means; but he complains of the *modus operandi* of the Glasgow Police Committee and Inspector of Smoke Nuisance, in pursuit of an object most laudable in the sight of every one "who has any regard for pure air and clean linen."

With regard to doing away with the smoke nuisance, it is very evident that more can be accomplished, by care and attention on the part of the fireman or stoker, than by the adoption of any peculiar specific. We therefore, call the attention of manufacturers, and coal burners generally, to this point—referring to our former observations on the subject, when noticing Mr. Buchanan's pamphlet.*

CORRESPONDENCE.

FORSTER'S HELIOSTAT.

The accompanying sketch represents an instrument, the design of which occurred to me some time since, when using Gambey's "Helio-stat."† The object of the common contrivance, hitherto in use, is to keep the sun's light steady on a particular point, in order that its phenomena may be the more easily observed. It contains an adjustment, whereby the light can be thrown on any point in the plane of the meridian; but my improved apparatus rectifies an important defect in the earlier arrangement, as in it the light may be thrown on any point whatever. On a small pedestal stand is placed a short level in the plane of the meridian, and carrying a graduated arc whereby the instrument is set. The reflecting mirrors are carried by a long balanced rod, attached by a universal joint to the stand. The mirror which receives the direct rays of the sun is capable of adjustment to any angle, with the aid of a small quadrant attached to it. This mirror is made to revolve once in twenty-four hours, about

the axis of the rod, by means of clockwork, contained in a small box,

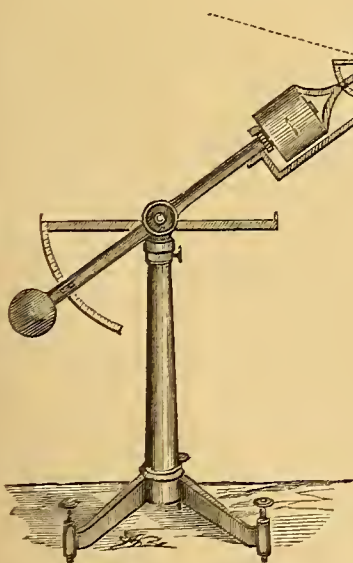

the axis of the rod, by means of clockwork, contained in a small box,

* See page 41, Vol. V., *Practical Mechanic's Journal*.
† See Pouillet's "Cours de Physique Experimentale."

forming a continuation of the rod. The second mirror, which receives the rays reflected by the first, is attached by a universal joint, in the line of the rod's axis, to a bracket extending round from the non-revolving part of the rod.

In using the instrument, the level is first adjusted in the plane of the meridian, and the main rod is set at an angle with it, equal to the latitude of the place. The angle of the first mirror is then made equal to one-half the complement of the sun's declination at the time, as obtained from the *Nautical Almanac*, and the mirror is turned from its present position 15° for every hour, before or after noon; the clockwork is then set agoing.

The principles of its operation will be obvious. The main rod being parallel with the axis of the earth, the sun will describe a uniform course about it, and the angle the sun's rays make with it will be constant, being equal to the complement of the declination. The sun's rays will consequently always be reflected in the direction of the rod's axis, and any required direction may then be given them by means of the second mirror.

Dublin, July, 1853.

R. FORSTER, JUN.

PREVENTION OF THE DEPOSIT IN STEAM BOILERS.

In the *Practical Mechanic's Journal* for July, mention is made of a plan for preventing the deposit in steam boilers, by Mr. Ira Hill, who uses oak sawdust for this purpose. I can vouch for the value of the preventive, as I have practised a similar method for some years with perfect success. Our water here, when used clean from the reservoirs, deposits a very fine coating of sulphate of lime. A few years ago we put up a new steam-engine, and this caused us to make entirely new arrangements for our boiler-water supply. We then took the water from the clean reservoir, as well as from some catch-water, after being used for washing prints. This washing-water was, of course, more or less charged with colouring matter or dye drugs, such as madder, sumach, logwood, and quercitron bark; and we now find, after using this coloured water for several years, that the boilers are as free from deposit, and as beautifully clean, as the first day of their working. In fact, I think they are now in better order than ever, as the plates are quite smooth and black. Of course, we require to blow off and clean from time to time, as a flocky precipitate forms in the boiler bottom; but this is easily swept out with a common broom. This deposit is, I presume, a partly chemical and partly mechanical combination of the colouring matter, with sulphate of lime. I was led to this idea from having, some years ago, pumped up the wash-wheel water from the dye-house, and mixed it with a mineral water pumped from a coal mine, expecting to improve the quality by the mixture. The water was afterwards filtered. I was glad to find a marked improvement from this combination of the two impure waters—the one charged with colour, and the other with sulphate of iron and sulphate of lime. There was an immense deposit in the reservoir where the mixture was left to settle.

JAMES BEVAN.

Bellfield Print-Works, Rochdale, July, 1853.

STEAM-PRESSURE GOVERNOR.

Could you suggest a good plan for making the variation of steam pressure—say of one or two pounds per square inch—throw on and off a small driving belt? There are many ways in which it may be accomplished, but you may possibly be able to give me a better one than any I can think of. The working pressure in the boilers is 37 pounds; therefore, with this as a standard, I want to be able to shift a belt on or off, or engage or disengage a clutch, with a varying range of one or two pounds steam pressure.

C. BLYTH.

Tay Works, Dundee, July, 1853.

[As our correspondent remarks, there are several ways of doing what he wants. There is, perhaps, nothing simpler than this:—

Let him fit up a continually revolving spindle, carrying a small cam or eccentric, working freely within an open frame, the two acting sides of which are set a little out of the same plane. This cam frame must form part of a rod passing to the belt forks, or to the clutch, as the case may be; so that when the frame is drawn to the right, it may set on the belt; or if to the left, it may throw it off; and it must be capable of a slight lateral motion, so as to bring either side into the same plane as the revolving cam. Connect this frame in any simple manner with the float or peg of a mercurial gauge, so that, when the column stands at 37 pounds pressure, the float may hold the frame in the centre of its

traverse. Then, on the rising or falling of the mercury, the action will shift the frame, so as to bring one or other of the planes into a line with the cam; and as the latter comes round, it will draw it to one side, and so shift the strap.—ED. P. M. JOURNAL.]

ELECTRODE ADJUSTMENT FOR THE ELECTRIC LIGHT.

I have been greatly interested in Dr. Watson's electric lamp, as given in a recent plate in the *Practical Mechanic's Journal*; and I now venture

Fig. 1.

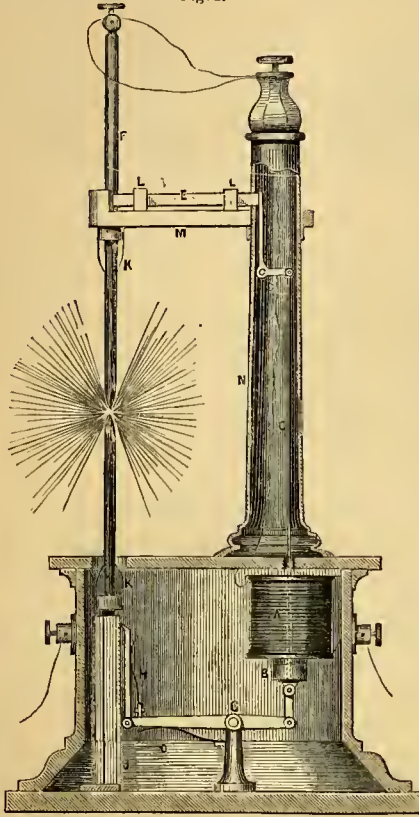

to send you a sketch of an arrangement of my own for a similar purpose. My plan is, I think, quite as efficient as Dr. Watson's, whilst the details are simpler and cheaper.

Fig. 1 is a partially sectioned elevation, corresponding to that given in your plate. It is one-fourth the real size; Fig. 2 is an enlarged detail in plan of the upper adjustment bracket; and fig. 3 is a horizontal section of the lower adjustment.

The electro-magnet is at A; and its armature, B, which is beneath, is shown in contact, so that the brass rod, C, passing through the centre of the magnet, is in its elevated position. The rod thus—by means of the bell-crank lever, D, bearing against the loose sliding-bar, E—holds the main vertical sliding-rod, F, in a fixed position. The armature, B, is screwed on to the lower end of its link-rod, C, so as to admit of easy adjustment; and it is

connected by a link on its lower side, with the shorter arm of the double lever, G, the opposite longer arm of which has a spring catch, H, jointed to it, and arranged to work in the finely toothed sliding ratchet-piece, J.

This ratchet terminates, as also does the upper sliding-rod, F, in a steel or platinum spring clip, K. The loose overhead bar, E, works in small guide eyes, L, on the bracket, M, and this bracket slides down with stiff friction upon the main pillar, X. The detailed sections,

Fig. 2.

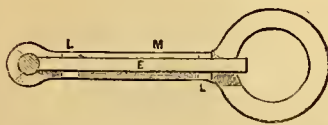

and the following explanation of the action, will, I think, make the whole quite clear to all who have examined your large plate. When, from the consumption of the electrodes, the distance between their points is increased so much as to stop the current, the spring, O, draws down the armature, B, and lifts the ratchet at the same time that the upper sliding-rod, F, is released. The electrodes thus simultaneously approach each other, and the requisite distance being attained, the consequent instantaneous renewal of the current fixes them both by the upward jerk of the armature.

Fig. 3.



Burton-on-Trent, July, 1853.

HENRY TURTON.

PROCEEDINGS OF SCIENTIFIC SOCIETIES.

INSTITUTION OF CIVIL ENGINEERS.

PREMIUMS—SESSION, 1852-53.

The Council of the Institution of Civil Engineers have awarded the following Premiums:—

1. A Telford Medal, to John Coode, M. Inst. C.E., for his "Description of the Chesil Bank."

2. A Telford Medal, to Daniel Kinnear Clark, for his "Experimental Investigation of the Principles of Locomotive Boilers."

3. A Telford Medal, to William Alexander Brooks, M. Inst. C.E., for his paper "On the Improvement of Tidal Navigation and Drainage."

4. A Telford Medal, to John Barker Huntington, Assoc. Inst. C.E., for his paper entitled, "Observations on Salt Water, and its application to the generation of Steam."

5. A Telford Medal, to Henry Potter Burt, Assoc. Inst. C.E., for his paper "On the nature and properties of Timber, with notices of several methods now in use for its preservation from decay."

6. A Telford Medal, to Thomas Duncan, Assoc. Inst. C.E., for his "Description of the Liverpool Corporation Water Works."

7. A Telford Medal, to Charles William Siemens, for his paper "On the Conversion of Heat into Mechanical Effect."

8. A Telford Medal, to Benjamin Cheverton, for his paper "On the use of Heated Air as a Motive Power."

9. A Telford Medal, to James Barrett, Assoc. Inst. C.E., for his paper "On the construction of Fire-Proof Buildings."

10. A Council Premium of Books, suitably bound and inscribed, to Joshua Richardson, M. Inst. C.E., for his paper "On the Pneumatics of Mines."

11. A Council Premium of Books, suitably bound and inscribed, to William George Armstrong, Assoc. Inst. C.E., for his paper "On the Concussion of Pump Valves."

12. A Council Premium of Books, suitably bound and inscribed, to Robert Rawlinson, Assoc. Inst. C.E., for his paper "On the Drainage of Towns."

13. A Council Premium of Books, suitably bound and inscribed, to James Sewell, for his paper on "Locomotive Boilers."

MONTHLY NOTES.

CARPET MANUFACTURE.—CROSSLEY v. POTTER.—ACTION FOR INFRINGEMENT.—In the year 1842, Mr. Thomas Thompson, of Coventry, obtained a patent for "certain improvements in weaving figured fabrics," and this grant, which has since passed into the hands of Messrs. Crossley, the eminent carpet manufacturers of Halifax, formed the subject of the present action. The counsel for the defendant, who is another large manufacturer at Darwen, called Mr. Thompson, the original patentee, who proved that the machinery invented by him was for the improved manufacture of carriage lace, and that at the time he discovered it he knew nothing of carpet-making, nor was it in his mind. It further appeared that, having made the discovery, and taken out a patent, he sold it to Messrs. Payne, by whom a specification (under which the plaintiff claimed) was prepared, extending the original patent to improvements in the manufacture of carpets. This specification Mr. Thompson declined to sign at first, under the impression that he would be called on to verify it, on oath, as being all his own invention; but being undeceived on that point, he eventually signed it for the consideration of £50. He now, however, stated, that all the subject-matter so specified was not his invention. Under these circumstances, the Chief Baron expressed himself to be of opinion that, if the jury gave credit to this testimony, the patent was not worth a farthing. If, at the time of the invention, Mr. Thompson knew nothing about carpets, but invented a new machine for improvements in the manufacture of carriage lace only, a specification subsequently prepared by a patent agent, embodying slight additions, extending the patent to machines for making carpets, could not be supported. On the plea, therefore, that no specification of Thompson's invention was duly enrolled, and on that denying the infringement, which went to the whole action, he should direct a verdict for the defendants, supposing the jury believed Mr. Thompson's evidence. After some discussion and further evidence, the jury intimated that they were all agreed in giving credit to Mr. Thompson's evidence, and thereupon a verdict was taken for the defendants, Mr. Atherton having tendered a bill of exceptions to the ruling of the Chief Baron.

STOLL'S PATENT.—This was an application to the Lord Chancellor to affix the Great Seal to a patent, applied for by Mr. John James Stoll, a Swiss gentleman, for "improvements in the manufacture of boots and shoes, and similar articles, and in machinery used therein, entitled, Metallic-toothed and Wedged Seams, and Waterproof, Elastic, Indented Stitches," and was opposed by Mr. Julian Bernard, the patentee of several inventions relative to the manufacture of boots and shoes by machinery, upon the ground, that so much of the invention as related to waterproof, elastic, indented stitches, was an infringement of Mr. Bernard's patents, and that another portion of the patent petitioned for, being the use of rollers for compressing leather for the soles of boots and shoes, in place of hammering the same, was not novel, as Mr. Brunel had used rollers for a similar purpose. The petition of Mr. Stoll had been opposed at the earlier stage of opposition, before the Solicitor-General, Sir Richard Bethell, who had given the following written decision upon the matter:—"From the very imperfect manner in which these inventions have been explained, and the non-exhibition of any specimens or models, I have had considerable difficulty in arriving at a satisfactory conclusion; but on an examination of the specifications, I am of opinion, that the third article or paragraph in Stoll's specification describes a mode of manufacturing which would be an infringement of Bernard's patent, of July, one thousand eight hundred and fifty-two, and I cannot therefore allow Stoll's patent to proceed with this (third) article of the specification. I have some doubt whether there may not be infringements in other respects, but the very insufficient explanations on both sides have not enabled me to arrive at any satisfactory conclusion, except as to the third article.—RICHARD BETHELL.—Lincoln's Inn, April 23rd, 1853."—Mr. Bernard, who has devoted

several years to the perfection of the machinery and processes patented by him, and who has expended a very large sum of money in carrying them out, was very naturally dissatisfied with this singular decision, and accordingly caused the opposition to be entered at the Great Seal. The case came before the Lord Chancellor on the 25th May, when Mr. Schomberg appeared for the petitioner, and Mr. Baggalay for Mr. Bernard. The petitioner, however, alleging that he had not had time to answer affidavits lodged by Mr. Bernard, the case was adjourned. When the matter came on before his Lordship again, on the 11th June, it was ordered to stand over, to give the Lord Chancellor an opportunity of seeing Professor Woodcroft, and directing him to inspect the specifications of both parties, and to report whether Stoll's patent was an infringement of Mr. Bernard's patents in any, and what respects. Professor Woodcroft having made his report, the matter again came on before the Lord Chancellor on the 9th July, when his Lordship dismissed the petition altogether, on the ground that three of the heads were infringements of Mr. Bernard's patents, and a fourth, the rolling leather, was not new, being, as alleged by the opposing party, the invention of Brunel. Mr. Schomberg applied, at a later period of the day, to have the patent sealed for the metallic toothed and wedged seams only; but his Lordship refused to entertain the application, and, in consequence, Mr. Stoll altogether loses his patent. The occurrence of cases of this nature must, we think, impress the authorities with the importance of the judgment of the law officers being aided by the experience of gentlemen who have devoted themselves to scientific pursuits. In this case, the Solicitor-General—having received, by the way, seven pounds for the trouble—in giving his opinion, expresses doubts whether other points are not infringements. Without, however, taking the trouble to obtain better evidence upon those points, the fiat for the patent was signed by him, and the parties were thus compelled to go to a higher tribunal, and to incur heavy expenses, for the satisfactory settlement of the question, whilst the matter was finally determined, upon the report of Professor Woodcroft, the Assistant-Commissioner of Patents, whose evidence was just as accessible in the earlier as in the later stage. When the appointment of Assistant-Commissioner was conferred upon Mr. Woodcroft, the public might well have expected that his well-known scientific attainments, and great experience in patent business, would be adopted in the arrangement of matters of this nature generally, without increased expense to patentees, the fees paid for oppositions being so high, more particularly as, under the new law, the opposing party is taxed with an additional payment of £2; the fees payable by both sides, on an opposition, being £9, in place of £6. 15s, under the old law. At present, however, this is not the case, and consequently, many cases similar to Mr. Stoll's may be anticipated.

PALMER'S CANDLES.—PALMER v. WAGSTAFF.—ACTION FOR INFRINGEMENT.—An action has just been tried in the Court of Exchequer, before the Chief Baron, for the recovery of compensation in damages, on account of an alleged infringement of a patent for making candles with plaited wicks. Mr. Palmer, the plaintiff, who is the well-known "candle-lamp" maker, obtained the patent in question in 1844, but only made a few dozens of the candles, and has not since acted upon it, except for the purposes of the present trial, nor has he ever sent the candles so made forth to the world. The Chief Baron, in leaving the case to the jury, said that, in legal language, it was a fraud on the law of patents for any person to take out a patent with a view to the obstruction of improvements by another. That was just the case where a man was proved to have taken out a patent, and never to have published it to the world, either by his own act of manufacturing the article under its specification, or by granting licenses to others to carry out the improvement which the invention so patented was said to have produced. One object of the invention was the production of a candle with a plaited wick, so that it would not require to be snuffed; but it would appear, that, prior to the patent, there had been candles made which possessed the same quality. Well, then, this patent had been taken out, had never been acted upon or published to the world by the patentee, and then, some years afterwards, when an improvement, in respect of plaited wicks to candles, was put forth by the defendant, he came down upon him with this action for damages. The jury would say whether any damage could have been sustained by a man who had never done anything under the patent, with the exception of obtaining and enrolling it. The jury, interrupting, said they had for some time arrived at the conclusion, that the plaintiff had not sustained any damage. The Chief Baron then said, that being their opinion, all they would have to do would be to consider, whether they were satisfied that the candle made by the defendant was similar to that proposed to be made under the plaintiff's specification. If it was, then they ought to give some damages. A farthing or 40s. would, perhaps, satisfy the issue. Upon that issue the jury at once returned a verdict for the plaintiff—damages, one farthing.

COTTON SPINNING.—ECCLES v. M'GREGOR.—ACTION FOR INFRINGEMENT.—This was an action for the alleged infringement of a patent, obtained by Mr. Eccles, of Walton, near Preston, in 1845, for a mule. The evidence referred back to Mr. Roberts' patent for a "self-actor," in 1830, and showed that, on the expiration of his patent in 1844, the plaintiff directed his attention to the matter, and in 1845 obtained a patent for the machine which he now claimed as his invention, and the idea and form of which he alleged to have been copied by the defendant. It was said that the plaintiff's machine was an improvement on that of Roberts, in consequence of the introduction of a different mode of applying the force to a chain which affected the rapidity of the movement of the wheels, and that, whereas by Roberts' machine the movement sometimes became slower towards the end of the operation, with the machine made by the plaintiff it became faster. In plaintiff's mule, a radial bar and fixed drum is used to regulate the motion of the spindles, with relation to the varying size of the "cop." The same advantage was obtained by the machine constructed by the defendant, which differed little in its form and in the arrangement of the various parts from that of the plaintiff, but which some of the witnesses decidedly preferred. The question in substance was, whether the

two machines were not reproductions of Roberts' invention, with but a slight difference in the application of one well-known power to remedy a well-known defect, such application not being in either of them the proper subject of a patent. The defendant denied the novelty and the usefulness of the plaintiff's invention. Much conflicting evidence resulted; but the defendant succeeded in adducing some strong points to show that the plaintiff had not usefully applied his own invention; and, in fact, that he had borrowed from the improved mules of other parties. Lord Campbell left it to the jury to say, whether the plaintiff's invention was new and useful, and whether the defendant had infringed it. The jury found their verdict on all the issues for the defendant.

RELATIVE PURITY AND GENERATION OF HEAT OF ARTIFICIAL LIGHTS.—The following table has been compiled by Professor Frankland, for the correction of the serious popular misconceptions as to the relative objections to the varieties of artificial light:—

Quantity of carbonic acid and heat generated per hour, by various sources of light equal to twenty sperm candles:—

	Carbonic acid.	Heat.
Tallow,	Cubic feet 10.1	100
Wax,	8.3	82
Spermaceti,	6.4	63
Sperm oil (Carcel's lamp),	5.0	47
London gases (coal),	4.0	32
Manchester gas,	3.0	32
London gas (Cannel),	2.6	19
Boghead hydro-carbon gas,	2.5	19
Lesmahagow hydro-carbon gas,		

Professor Frankland adds:—"The two objections most frequently advanced against the use of gas in dwelling-houses, are the deterioration of the air by the production of carbonic acid, and the evolution of so much heat as to render the atmosphere oppressively hot. It will be seen, from the comparison exhibited, that in these respects even the worst descriptions of coal gas are, for an equal amount of light, superior to all other illuminating materials; whilst, with the better descriptions of gas, three or four times the amount of light may be employed with no greater atmospheric deterioration."

PRUSSIAN BLUE.—This beautiful colour was originally brought to light in Berlin, and hence it is occasionally called "Berlin blue." Its manufacture exhibits a steady growth, of most remarkable rapidity of increase. The annual production in this country for the last twenty-seven years being—

From 1825 to 1830, about	10 tons.
" 1830 to 1835, "	40 "
" 1835 to 1840, "	200 "
" 1840 to 1845, "	700 "
" 1845 to 1850, "	1040 "

And the present annual manufacture is about 2000 tons. The price of the best is from 3s. 6d. to 4s. a pound, or £255 per ton.

CONSUMPTION OF PIG-IRON IN SCOTLAND.—The following statement shows the actual rate of increase in the consumption of pig-iron in Scotland, as made out by a comparison of the respective first half years of 1852 and 1853:—

	1852.	1853.
In the wrought-iron manufacture,	60,000	80,000
In iron-foundries:—		
Lanarkshire,	52,000	56,000
Other Western Counties,	20,500	24,000
Eastern Counties,	6,000	6,500
North of the Forth,	7,000	8,500
	85,500	95,000
Increase of consumption in 1853:—		
In malleable iron-works,	20,000	
In iron-foundries,	9,500	
Total, about	29,000 tons.	

AN AMERICAN OPINION ON AMERICAN INDUSTRIAL CAPABILITIES.—The American people, of all others, possess mechanical traits of character which have and are destined to make them the most wonderful nation on the globe. They are not contented to copy or to follow in the footsteps of their mother-country; their conceptions and developments are emphatically their own. While England builds ships from Newton's formula of the curve of least resistance, Americans construct them from the formula of error and trial, as developed at Cowes. Americans project and complete railroads of great magnitude without any apparent effort; but English engineers must first have the relation of the ordinates of the greatest curve and the nature of the highest grades considered by the Royal Society, before the first steps are taken. They become alarmed if the pressure of the steam upon their boats reaches a few pounds above the elasticity of the atmosphere, while we delight and glory to listen to the escape of the blue vapour under the enormous pressure of 150 or 200 pounds. They made nails by units, until the Americans taught them the art of manufacturing per thousand. They made pins by hand, until American mechanics discovered a method of performing manual labour by machinery. They spun upon Arkwright's patents until Danforth and Thrope

(Americans) produced greater inventions. They fought the battles of Marston Moor and Waterloo with the arms of a former age, which are now being superseded by the inventions of Colt, Porter, and other Americans. And thus we could continue to add proof of what we first asserted, that the Americans possess mechanical traits of the highest grade; and it will be found, upon examination, that their extraordinary success as a nation emanates, in a great measure, from these developments. The substitution of motive power for physical labour has been carried to a greater extent in this than in any country in the world, and this is universally admitted to be the greatest lever of civilization that mankind has ever been able to bring to their aid. America, at the present time, has employed motive power more than equivalent to all the physical labour of the human family combined. In the great magazine of nature, there slumbers a power which the American mind is now awaking into existence, which is able and will perform in time all the labour and drudgery to which the miserable of mankind are now subjected.—*The Mechanic.*

RETIRING PENSIONS TO ENGINEERS, R.N.—We are extremely gratified to be able to announce the issue of an Order in Council, for setting right the engineers of the navy, on a point which has all along been utterly neglected. This is the question of superannuation allowances, which the recent order determines as follows:—Inspectors afloat are to receive from £130 to £180; chief engineers, who have served twelve years in that rank, £100 to £130; after six years, £85 to £105, and after three years, £75 to £90; assistant-engineers, after twenty years' service, from £50 to £60, and after three years from £40 to £50.

LITERATURE, SCIENCE, AND ART, IN THE HOUSE OF COMMONS.—A recent pamphlet, entitled *Parliamentary Reform—Educational Franchise*—has awakened the long slumbering question of a more adequate representation of pure intellect in our legislative councils. Of the three great interests—manufactures and commerce, agriculture, and education and intelligence—it would be absurdly unnecessary to point out the weakest, as regards parliamentary, and, consequently, progressive influence. The brief production in which we have referred, conveys a proposition for supplying the undeniable want. The nameless author proceeds by recommending the establishment of certain "educational qualifications" for the creation of electors; and he comes first to divinity, law, and physic; then to retired and half-pay officers. These are followed by "learning and education"—under which head he includes "all who have passed an examination for the degree of B.A. at Oxford or Cambridge; all professors and graduates of the University of London—an increasing class; all professors and graduates of the Scotch Universities; all graduates of Durham and St. David's; and all certificated schoolmasters—an increasing class." An eighth class is to be composed of adepts in "literature, science, and art," including Fellows of the Royal Societies of London and Edinburgh; Fellows of other societies, possessing certain distinctions; Fellows of Architectural and Engineering Institutes; Royal Academicians; committee-men of the British Association; existing presidents or acting secretaries of certain other institutions; and members of the Royal Society of Literature, "or of a Literary or Authors' Institute, should such be formed." He thus proposes to produce some 90,000 electors, and apportions to them 70 M.P.s—these members being returned from certain districts, by the aggregate votes of a general fusion of the scientific and general educational electors of each locality. He assigns these members thus:—6 to Middlesex, 6 to Lancashire, 6 to Yorkshire, 3 to Surrey, 2 to Devonshire, 2 to Somersetshire, 1 to Cumberland and Westmoreland, 1 to Huntingdonshire, Cambridgeshire, and Rutlandshire, 1 to Herefordshire and Monmouthshire, and 28, in the whole, to the remaining counties of England—numerical population being the basis of the calculation throughout. This makes 56 for England altogether; and of the remaining 14, 11 are allotted to Scotland, and 3 to Wales. The 70 representatives thus arising are to be substituted for 70 of the existing ones, who are to be withdrawn from the House; so that the actual number meeting at St. Stephens will remain as at present. The idea is a laudable one; but it is not difficult to foresee many practical objections to the project.

THE NEW YORK EXHIBITION.—After many serious and vexatious delays, this industrial display has at length been opened. The inauguration only took place on the 15th of July, so that we are unable to furnish any notes upon it until the appearance of our September part. Meanwhile, we give the following notice just issued by the directors:—"It is proper that it should be known that, in order to afford ample scope for the inventive talent and skill of our countrymen in machinery and agricultural implements, we have increased the size of the building by adding nearly one-fourth to its area beyond what was originally contemplated, so that we have now for the purposes of exhibition two hundred thousand square feet, or nearly five acres. Not limiting their plans to a display merely curious or attractive, the directors have organized a department of mineralogy and geology, in which some of the best scientific talent of the country has been employed; and the foundation is thus laid of a most valuable national collection of the mineral resources of the country. The directors had hoped to open the Exhibition at an earlier period; but the novelty and intricacy of the style of construction, and the high standard of architectural beauty, which it has been the object of the Association to attain, have produced delay, and it has been impracticable for the directors, notwithstanding their utmost vigilance, and their most earnest desire, to announce the opening at an earlier day. In regard to the general character of the Exhibition, the result promises to be most gratifying and not unworthy of the confidence manifested towards it by the Government of the United States—a confidence which has elicited a cordial response from the Governments of foreign countries. It will, unquestionably, be the most attractive and interesting collection of the works of art, the results of science, and the productions of industry, that has ever yet been made in this country, and will tend to increase the active emulation of the age in every branch of intellectual development. The sole charge of the interior of the building, its divi-

sion, arrangements, classification, and police, has been confided to two officers of the navy of the United States, Captains S. F. Dupont and C. H. Davies; and the sanction of the Government given to the appointment of these gentlemen, who have so much distinguished themselves in the special services in which they have been employed, affords proof of the confidence reposed and the interest felt by the highest authorities of the country in the general objects of the enterprise. These gentlemen have organized their department as follows:—J. M. Batchelder, Secretary of the Superintendent; Samuel Webber, Arrangement of Space and Classification; Professor B. Silliman, Jun., Mineralogy and Chemistry; B. P. Johnson, Agricultural Implements; Joseph E. Holmes, Machinery; Edward Vincent, Textile Fabrics; Felix Piatti, Sculpture." Our own Exhibition in Dublin is now in full and successful working order, and we shall give our impressions of it next month also.

PROVISIONAL PROTECTIONS FOR INVENTIONS

UNDER THE PATENT LAW AMENDMENT ACT.

☞ When the city or town is not mentioned, London is to be understood.

Recorded February 5.

322. André M. Massonnet, Paris, and 16 Castle-street, Holborn—Certain improvements in alloys of metals, and of other substances, and also in the application of the same to various useful purposes.

Recorded March 30.

761. Louis M. Lomhard, Paris—Improvements in obtaining motive power.

Recorded April 2.

786. Sir James C. Anderson, Bart., Fermoy, Ireland—Improvements in locomotive engines.

Recorded April 18.

934. Hans W. Allen, 98 Great Portland-street, London, and 19 Montpellier Terrace, Cheltenham—Invention of a furnace, which he calls the "Vestal Furnace," for carbonization of peat or turf, or other substances.

Recorded May 7.

1131. Conrad W. Finzel, Bristol—An improvement in refining sugar.

Recorded May 10.

1141. Frederick Lipscombe, 233 Strand—Improvements in obtaining motive power.

1151. John H. Johnson, 47 Lincoln's-inn-fields, and Glasgow—Improvements in machinery or apparatus for effecting agricultural operations.—(Communication.)

Recorded May 21.

1258. William Chisholm, Holloway, Middlesex—Improvements in the purification of coal gas for the purposes of illuminating and heating, and obtaining by the ingredients used there for manures, salts of ammonia, and sulphur.

1326. George Wells, 15 Upper East Smithfield—Invention for the combination of materials for making a more perfect fabric for suction-hose, mill-hands, harness, and for all other similar purposes to which the same may be applied.

Recorded May 26.

1301. John Nurse, Crawford-street, Bryanstone-square—Improved mechanism for fastening and unfastening doors, applicable especially to the doors of carriages.

Recorded May 27.

1309. William W. Bonney, West Brompton—Improvements in machinery for raising a pile or flue by abrasion on linen, cotton, silk, and other fabrics.

Recorded May 28.

1313. Ebenezer Nash, Duke-street, Lambeth, and Joseph Nash, Thames-parade, Pimlico—Improvements in the manufacture of wicks.

1321. Edward D. de Boussois, Paris—Improvements in preventing incrustation of steam boilers.

Recorded May 30.

1325. Joseph Brown, 71 Leadenhall-street—An invention for the improvement of elastic spring beds, mattresses, cushions, and all kinds of spring stuffing for upholstery work generally, making them lighter and more portable.

Recorded June 1.

1343. John W. Thomson, Forest-hill, Sydenham—Improvements in heating hot-houses, hot-beds, pits, conservatories, houses, churches, and other buildings.

Recorded June 3.

1364. James Mayelston, Elloughton, York—Certain improvements in the manufacture and refining of sugar.

Recorded June 6.

1390. Frederick Lott, 9 Bloomfield-place, Pimlico—Improvements in cartridges.

1392. Delahere Barker, Douglas-road, Islington—Certain improvements in the manufacture of blinds, shades, and other screens, from glass, and other vitrious substances; also, in the method or methods of raising, lowering, folding, and regulating such blinds, shades, and other screens.

Recorded June 7.

1394. George B. C. Levenson, 12 St. Helen's-place—Invention of a new application, construction, and arrangement of springs for carriages, and such like purposes.—(Communication.)

Recorded June 9.

1405. George Bott, Birmingham—Invention of a new or improved method of preventing collisions on railways.

1406. Henry B. Barlow, Manchester—Improvements in machinery for spinning, doubling, and twisting cotton and other fibrous substances.—(Communication.)

1407. George W. Garrod, Maldon, Essex—Improvements in propelling vessels.

1409. Claude Arnoux, Paris, and 4 South-street, Finsbury—Invention of a new system of towing and traction.

1410. William Muir, Manchester—Improvements in turning-lathes, a part of which improvements is applicable to other useful purposes.

1411. Joseph Smith, Bradford—Certain improvements in machinery for preparing and spinning wool, hair, silk, flax, and other fibrous substances.

1412. Joseph Smith, Bradford—Certain improvements in combing wool and other fibrous substances.

1413. Edward Maniere, Bedford-row, Middlesex—Improvements in the manufacture of paper.

1414. William Brookes, 73 Chancery-lane—Improvements in treating fabrics suitable for floor cloths, covers, and such like articles.—(Communication.)
 1415. William Brookes, 73 Chancery-lane—Improvements in the manufacture of boxes and other hollow receptacles.—(Communication.)
 1416. James R. Napier, Lanefield, Glasgow, and William J. M. Rankine, Rutherglen—Improvements in engines for developing mechanical power by the action of heat on air and other elastic fluids.

Recorded June 10.

1417. Anguste Chesneau, Leicester—Invention of a new method of obtaining steam power.
 1419. Josiah Moore, Clerkenwell-Close, Middlesex—Improvements in respirators.
 1420. Samuel Frankham, Greenland-place, Judd-street, Middlesex—An improved construction of coupling joint applicable to pipes, vessels of capacity, and other like uses.
 1421. Alfred V. Newton, 66 Chancery-lane—An improvement in spining machinery.—(Communication.)
 1422. Richard A. Brooman, 166 Fleet-street—Improvements in the manufacture of paper.—(Communication.)
 1423. Joseph Westwood and Robert Baillie, Poplar, Middlesex—Improvements in the construction of iron ships.

Recorded June 11.

1424. Christopher Nickels, Albany-road, Surrey, and James Hobson, Leicester—Improvements in the manufacture of carpets and other piled fabrics.
 1425. Christopher Binks, Albert Villa, North Woolwich—Improvements in dryers and in preparing drying oils for paints, varnishes, and other uses.

Recorded June 13.

1426. Hugh O'Connor, Frederick-street, Limerick—Invention for digging the soil by means of machinery with horse power.
 1427. William H. Smith, Bloomsbury, Middlesex—Improvements in the permanent way of railways.
 1428. William Smith, Sheffield—Improvements in the mode of manufacturing metallic handles for knives and forks, hacks for razors, bows for scissors, and the relative parts of such like instruments.
 1429. John Marsh, Theophilus Marsh, James Marsh, and Walter Marsh, Sheffield—Improved mode of fastening the handles of table knives and forks.
 1430. Joseph Spencer, Bilston—A new or improved cupelo.
 1431. Thomas J. Perry, Birmingham—Improvements in raising and lowering Venetian and other blinds, applicable also to the raising and lowering of other bodies.
 1423. William D. Paine, Lambeth, and George A. Paine, Clark's-mews, Marylebone—Improvement in the construction of steam-boilers, and in steam-boiler furnaces.
 1434. Gonsal A. H. J. Fremin, Paris, and 4 South-street, Finsbury—Certain improvements in the construction of steam-boats.
 1435. Robert Hopkins, Manchester—Improvements in machinery or apparatus for cutting and shaping cork-wood and other similar substances.
 1436. Joseph Webb, Mayfield-terrace, Dalston—Improvements in obtaining motive power.

Recorded June 14.

1437. William G. Craig, Newport, Monmouth—Improvements in axle-boxes, guides, and bearings of locomotive engines and carriages, parts of which improvements are applicable to the bushes and bearings of machinery.
 1438. Robert W. Sievier, Upper Holloway, and James Crosby, Manchester—Improvements in looms for weaving.
 1439. Joseph H. Penny and Thomas B. Rogers, New York—A new and useful improvement in the manner of constructing machinery for propelling vessels and other machinery, which they term a crank propeller.
 1440. John H. Johnson, 47 Lincoln's-inn-fields, and Glasgow—Improvements in railway brakes.—(Communication from Francis A. Stevens, United States.)
 1441. Thomas Richardson, Newcastle-upon-Tyne—Improvements in the manufacture of certain salts of magnesia, and a red colouring matter.
 1442. Joseph L. Talbot, Paris, and John D. M. Stirling, Birmingham—Improvements in the manufacture of iron.
 1443. Alfred V. Newton, 66 Chancery-lane—An improved mode of manufacturing cast steel.—(Communication.)

Recorded June 15.

1444. George Burstall, Fenchurch-street—Improvements in the bleaching of oils and fats, and in machinery and apparatus connected therewith.
 1445. Arthur Parsley, 3 Crescent-place, Burton crescent—A revolving engine, to be worked by steam, air, gases, or water.
 1446. Thomas Butterworth, Meanwood, Yorkshire—Invention of a machine for ploughing land, harrowing, and crushing clods at one operation.
 1448. Alexander Robertson, Holloway, Middlesex—Improvements in vessels or cases for storing and preserving edible substances.
 1449. Charles W. Williams, Liverpool—Improvements in the manufacture of sheet-iron, and of iron plates used for boilers, vessels, buildings, and other like purposes.
 1450. John Macintosh, Pall Mall East—Improvements in the construction of portable boats or vessels and buoys.
 1451. Jules Dehan, 39 Rue Pigale, Paris—Improvements in the manufacture of yarn, and fabricating articles therefrom.
 1452. Jules Dehan, Paris—Improvements in the manufacture of woven fabrics, yarn, cordage, ropes, paper, and pasteboard, by the application of a material not hitherto used in Great Britain for such purposes.
 1453. James Dilkes and Edward Turner, Leicester—Improvements in door-springs.
 1454. John J. Payne, Upper King-street, Bloomsbury—Certain improvements in axles.
 1455. William Gossage, Widnes, Lancashire—Improvements in obtaining certain saline compounds from solutions containing such compounds.
 1456. John Elliott, Oak-lane, Limehouse, and John Brown, same place—Improved machinery for making rivets, spikes, and screw blanks.
 1457. Timoléon Z. L. Maurel, Paris, and 16 Castle-street, Holborn—Certain improvements in horological alarms.

Recorded June 16.

1458. William Baddeley, 13 Angell-terrace, Islington—An improved label damper.
 1459. Edward Walmsley, Heaton Norris, Lancaster, and John Holmes, Manchester—Improvements in and applicable to steam-engines.
 1460. William H. G. Field, Kennington—Certain improvements in the construction of barges and vessels, and in the mode of steering.
 1461. William Christopher, Euston-square, and Gustavus Gidley, Robert-street, Hoxton—Improvements in abstracting sulphur and other matters from vulcanized India-rubber.
 1462. John Blair, Newmilns, Ayrshire—Invention of a new and improved method of cutting lappet cloths or other similar fabrics.
 1463. James W. Gibson, 129 Longacre—A new method of pavement tending to secure the evenness of the road and proper adhesion to the foot.
 1465. Joseph Hsley, Lisbon—Improved telegraphic apparatus.
 1466. Richard A. Brooman, 166 Fleet-street—Improvements in machinery for sawing stone and marble.—(Communication.)

1467. Peter A. Le Comte de Fontaine Moreau, 39 Rue de l'Echiquier, Paris, and 4 South-street, Finsbury—An improved process for preserving milk, and its application to several organic products, and alimentary substances.—(Communication.)
 1469. Clinton Roosevelt, New York—Invention for reducing the friction of the journals of railway and other carriages, which is also applicable to the journals of machinery.
 1470. Robert M. Glover, Newcastle-upon-Tyne, M.D.—Improvements in the production of chlorine, and for the manufacture of black oxide of manganese.
 1471. Benjamin Finch, Dublin—Improvements in apparatus for supplying water to steam boilers.
 1472. Joseph Warren, Maldon—Improvements in ploughs.
 1473. Solomon Solomon, Aldgate, and Samuel Mills, St. George's-in-the-East—Improvements in axle-boxes for locomotive engines, railway and other carriages, applicable to the bearings of machinery.

Recorded June 17.

1474. Edward Rodgers, Livsey-street, Manchester—An improvement in looms for weaving.
 1475. Christopher Waud, Edward Waud, and William Busfield, Bradford, York—Improvements in preparing wool and other fibrous substances.
 1476. Auguste E. L. Belford, 16 Castle-street, Holborn—Improvements in machinery for pulverizing and washing quartz or ore, and for amalgamating the gold contained therein.—(Communication.)
 1477. Auguste E. L. Belford, 16 Castle-street, Holborn—Improved stove or kiln.
 1478. Robert Lister, Scotswood, Northumberland—Improvements in chimney tops or flues.
 1479. Henry Bleasdale and Joseph Bleasdale, Chipping, Lancaster—Improvements in working, tilling, or preparing land.
 1481. John Piddington, Brussels—Improvements in obtaining infusions and decoctions, and in vessels or apparatus employed therein.—(Communication.)

Recorded June 18.

1482. William Hall, Aberdeen—Improvements in ship building.
 1483. Henry Essemser, Baxter house, Old St. Pancras road—Improvements in the manufacture of waterproof, or partially waterproof, fabrics.
 1484. Henry Saunders, Yeovanev Staines—Improvements in drying grass and other crops.
 1486. Edgar Breffit, Castleford, York—Improvements in the manufacture of glass-house pots.
 1488. Thomas Adamson and William Adamson, Sunderland—Improvements in pumps.
 1489. James Heginbottom and Joseph Heginbottom, Ovenden, York—Improvements in spinning.
 1490. James Shanks, St. Helen's, Lancaster—Improvements in the manufacture of alkali from common salt.
 1491. John M. Hyde, 1 Quay, Bristol—Improvements in steam-engines, and the production of steam for the same.
 1492. William A. Gilbee, 4 South-street, Finsbury, and Paris—Invention of a new mode of ornamenting stuffs and paper.—(Communication.)
 1493. James Worrall, jun., Salford, Lancaster—Certain improvements in machinery or apparatus for washing, bleaching, and dyeing fustians, beavertraces, cantoons, satcens, twills, and other textile fabrics.
 1494. John C. Richardson, Lilly-hill, near Manchester—Certain improvements in machinery or apparatus for winding yarn.
 1495. John C. Richardson, Lilly-hill, near Manchester—Certain improvements in looms for weaving.
 1496. George Robinson, Manchester—Certain improvements in apparatus for roasting and desiccating coffee, cocoa, and chicory.
 1497. Samuel Schofield, Oldham—Certain improvements in machinery or apparatus for preparing and spinning cotton and other fibrous materials.
 1498. George Young, Neath, South Wales—Improvements in grinding wheat and other grain.

Recorded June 20.

1499. Charles Crickmay, Handsworth, Stafford—Improvements in the construction of fire-arms.
 1500. John Paul, Manchester—Invention of colouring paper on the surface.
 1501. Robert Midgley, Northowram, York—Improvements in preparing and finishing certain worsted yarns, and in apparatus employed therein.
 1502. Hiram Barker, Manchester, and Francis Holt, same place—Improvements in machinery and apparatus for grinding and turning metals.
 1503. William Bogget, St. Martin's-lane, and George B. Pettit, Lisle-street—Invention of improvements in dioptric refractors.
 1504. William Hodgson and Henry Hodgson, Bradford—Improvements in machinery for spinning wool, hair, silk, flax, and other fibrous substances.
 1505. John W. Perkins, Narrow-street, Limehouse—Improvements in the manufacture of artificial manure.
 1506. William E. Newton, 66 Chancery-lane—Improved machinery for drilling or boring rocks, or other hard substances.—(Communication.)
 1507. William E. Newton, 66 Chancery-lane—An improved manufacture of handles for knives and other similar articles.—(Communication.)
 1508. Charles L. Delever, Steenbrugge les Bruges, Belgium—An improved preparation for lubricating machinery.
 1509. Richard Cornelius, Old Town-street, Plymouth—Improvements in the construction of churns for producing butter.
 1511. Allan Macpherson, Brussels—Improvements in disinfecting sewers or other drains, and in converting the contents thereof to useful purposes.
 1513. Pacifico Grimaud, Paris, and 4 South-street, Finsbury—Invention of a new aerogeous drink, which he calls "Grimaudino."
 1514. Henry Blatin, Paris, and 4 South-street, Finsbury—Improvements in buckles.

Recorded June 21.

1515. Charles Cowper, Chancery-lane—Improvements in the manufacture of cards, or substitutes for cards for the Jacquard loom.—(Communication.)
 1516. Joseph Newton, Ickwell, Bedford—Improved apparatus for heating buildings, applicable also to horticultural purposes, and to hatching and rearing poultry and game.
 1517. Thomas Wilson, Manchester—Improvements in screens, or machinery for cleaning wheat and other grain.
 1518. John Drummond, Edinburgh—Invention of a reaping machine.
 1519. Juste Giret, Paris, and 4 South-street, Finsbury—Certain improvements in artificial and malleable stones, and in the apparatus to be used for such purposes.
 1520. John Leach, Over Darwen, Lancaster—Improvements in looms for weaving.

Recorded June 22.

1521. John H. Noone, 53 Salisbury-street, Portman-market—An improved method of stopping railway trains and preventing railway accidents.
 1522. Frederick Ayckbourn, 99 Guildford-street, Russell-square—Improvements in the manufacture of waterproof fabrics.
 1523. Francis Huckvale, Choice-hill, Chipping Norton—Improvements in hand hoes.
 1524. William Geeves, New Wharf-road, Calcedonian-road, Middlesex—Improvements in the manufacture of bricks.

1525. Charles Topham, Hoxton, Middlesex—Improvements in apparatus for measuring liquids, gases, and other elastic fluids, and for regulating the flow thereof, which apparatus may also be applied to the obtaining of motive power.

Recorded June 23.

1526. George L. Stocks, Limehouse-hole, Poplar, and Thomas Watson, 49 Buttesland-street, Hoxton—Improvements in the construction of ships' square sails, and in the method of reefing the same.

1527. Noel N. du Chastaingt, Paris, and 4 South-street, Finsbury—An improvement in bread-making.

1528. James Burrows, Wigan—Certain improvements in the construction of steam-boilers or generators, and in the arrangement of furnaces connected therewith.

1529. James Burrows, Wigan—Certain improvements in the formation of such metallic plates as are required to be conjoined by rivetting or other similar fastening.

1530. Thomas W. Dodds, Rotherham—Improvements in the manufacture of files, rasps, and other edge tools usually made of steel.

1532. Joseph Aspinall, Liverpool, and 16 Castle-street, Holborn—Invention of a self-adjusting stamp.—(Communication.)

1533. Masta J. Cooke, Newcastle-on-Tyne—An improved mill and apparatus for crushing and grinding bones, grain, and other compounds.

Recorded June 24.

1534. Joshua Horton, jun., Brierly-hill, Staffordshire—Improvements in steam-boilers.

1535. Joseph Rock, jun., Birmingham—Improvements in spring or clasp-knives, applicable to such other articles as shut or close after the manner of clasp-knives.

1536. Noble C. Richardson, South Shields—Invention of an improved capstan.

1537. George S. Sidney, Brixton-road, Surrey—Improvements in jugs or vessels for containing liquids.

1538. John Webster, Ipswich—Improvements in the distillation of fatty and oily matters.

1540. John H. Johnson, 47 Lincoln's-inn-fields, and Glasgow—Improvements in obtaining motive power.—(Communication from Messieurs Guichené and Burgalat.)

1541. John H. Johnson, 47 Lincoln's-inn-fields, and Glasgow—Improvements in the production or manufacture of flour.—(Communication from M. Buiroz.)

1542. John H. Johnson, 47 Lincoln's-inn-fields, and Glasgow—Improvements in machinery or apparatus for cutting paper and similar materials.—(Communication from M. Pfeiffer.)

1543. James M'Connell, Hazeldean, Renfrewshire—Improvements in the consumption or prevention of smoke.

1544. John Lyle, Glasgow—Improvements in the manufacture of figured or ornamental fabrics.

1545. Henry Goodall, Derby—Improved machinery or apparatus for grinding or levigating various substances.

1546. Leon Valls, Paris—Improvements in the production of printing surfaces.—(Communication.)

Recorded June 25.

1547. Daniel Illingworth, Alfred Illingworth, and Henry Illingworth, Bradford—Improvements in machinery or apparatus for combing wool, cotton, flax, silk, and other fibrous substances.

1549. John E. Lightfoot, Accrington—An improvement in the manufacture of certain colouring matter to be used in dyeing and printing.

1550. George J. Mackean, Gloucestershire—Improvements in winnowing or corn-dressing machines.

1551. Alfred Sandoz, Switzerland—Invention of an instrument or apparatus, which he terms a solar watch.—(Communication from the inventor, Philippe H. M. Doret, Switzerland.)

Recorded June 27.

1552. Robert Harlow, Stockport—Improvements in constructing and working valves for baths, washstands, and other purposes.

1553. Richard A. Brooman, 166 Fleet-street—Improvements in printing or in producing designs and patterns on stuffs and fabrics.—(Communication.)

1554. William Fairclough, Stockport—Certain improvements in looms for weaving.

1555. John Mason, Rochdale, and Luke Ryder, same place—Improvements in machinery or apparatus for preparing and spinning cotton and other fibrous substances.

1556. Alfred V. Newton, 66 Chancery-lane—Improved apparatus for manufacturing resin oil.—(Communication.)

1557. George French, Bandon—Improvements in axles or axletrees.

Recorded June 28.

1558. John Jarman, Manchester—Improvements in apparatus for measuring corn, pulse, seeds, or other produce, usually sold by dry measure.

1559. Carlo Minasi, Camden Town, Middlesex—Improvements in concertinas.

1560. Alexander Brown, Glasgow—Improvements in the manufacture of cotton fabrics for ladies' under-dresses.

1561. Auguste E. L. Bellford, 16 Castle-street, Holborn—Improvements in steam-boilers.—(Communication.)

1562. Auguste E. L. Bellford, 16 Castle-street, Holborn—Improvements in magneto-electric machines.—(Communication.)

1563. John H. Johnson, 47 Lincoln's-inn-fields, and Glasgow—Improvements in turning over the leaves of books, music, and engravings, and in the apparatus for effecting the same.—(Communication from Claude Desbeaux, Paris.)

Recorded June 29.

1564. Thomas E. Irons, Arbroath—Improvements in the manufacture of lasts, and in machinery connected therewith, parts of which machinery are also applicable to other like purposes of eccentric turning.

1565. Frederick Steiner, Hyndburn, near Accrington, Lancaster—Improvements in the manufacture of wooden rollers or cylinders.

1566. Peter A. le Comte de Fontaine Moreau, 4 South-street, Finsbury, and Paris—Improvements in the construction of furnaces.—(Communication.)

1567. John Patterson, Beverley, York—Improvements in machines for reaping and mowing corn, grass, and other crops.

1568. Robert M. Stevier, Manchester—Improvements in the manufacture of piled fabrics and in machinery for effecting the same.

1570. George A. Biddell, Ipswich—Improvements in apparatus for cutting vegetable and other substances.

1571. Pierre A. de S. S. Sicard, Paris—Improvements in apparatus for facilitating the raising, moving, and breaking up of sunken vessels and other submerged substances.

1572. James Tatlow, Wirksworth, Derbyshire, and Henry Hodgkinson, same place—Improvements in smallware looms.

1573. Lemuel W. Wright, Chalford, Gloucester—Improvements in the permanent way of railways.

Recorded June 30.

1574. Elias R. Handcock, 58 Pall Mall—Certain improvements in mechanism to decrease friction in propelling machinery, and to compensate for the wear thereof, and to strengthen the driving parts.

1575. Auguste E. L. Bellford, 16 Castle-street, Holborn—Improvements in the construction of submarine or subaqueous tunnels or ways.—(Communication.)

1576. Williams Rice, Boston, Lincolnshire—Improvements in harness for horses and other animals, and in the manufacture of springs for the same.

1577. Joseph Webb, Mayfield Terrace, Dalston, Middlesex—Improvements in obtaining and applying motive power.

1578. George Sterry, Worcester—An improved method of producing designs and patterns in wood.

1579. Andrew P. Howe, Mark-lane—Invention of an engine meter or instrument for indicating the number of strokes of an engine.—(Communication.)

1580. Edward Davies, Gothenburg, Sweden—Improvements in machinery or apparatus for carding and otherwise preparing cotton or other fibrous materials to be spun, and also for cleaning or stripping cards used in the said operations.

1581. William C. Spooner, Eling House, near Southampton—Improvements in drills for agricultural purposes.

1582. William Tasker, Andover, Hants—Improvements in drills for agricultural purposes.

Recorded July 1.

1583. Richard Bradley and William Craven, Wakefield—Improvements in the moulding, forming, and compressing of clay for the manufacture of bricks, tiles, and other earthenware.

1584. Philip Hart, Brierly-hill, Stafford—Improvements in the manufacture of coke.

1586. George Parsons, West Lambrook, Somerset—Improved machinery for thrashing, winnowing, and dressing corn, grain, and seeds.

1587. Edward C. Shepard, Trafalgar-square, Middlesex—Improvements in magneto-electric apparatus, suitable for the production of motive power of heat and of light.—(Communication.)

Recorded July 2.

1588. John Rollinson, Kingswinford, and William Rollinson, Brierly-hill, Staffordshire—Invention of a new or improved apparatus for preventing explosions in steam boilers.

1590. Lemuel W. Wright, Chalford, Gloucester—Improvements in machinery or apparatus for reducing and pulverising gold and other metalliferous quartz and earths, and in separating metal therefrom.

1591. Edward C. Shepard, Trafalgar-square, Middlesex—Improvements in the manufacture of gas.—(Communication.)

1592. Richard A. Brooman, 166 Fleet-street—Certain machinery for converting caoutchouc into circular blocks or cylinders, and for manufacturing the same into sheets.—(Communication from François Peroncel, Paris.)

1593. Richard A. Brooman, 166 Fleet-street—Improvements in impregnating, saturating, or coating threads, yarns, and fabrics with metal, which process the inventor terms metallic dyeing.—(A communication from Charles Depouilly, Paris.)

Recorded July 4.

1595. Gabriel D. Fevre, Paris, and 16 Castle-street, Holborn—An improved vessel to be used for the purposes of infusion and decoction, heating liquids, and melting glutinous substances.

1597. George F. Parratt, Piccadilly—Improvements in portable bridges, rafts, or pontoons.

Recorded July 5.

1598. Henry Meyer, Manchester—Certain improvements in looms for weaving.

1599. Marcus Davis, 52 Gray's-inn-lane—Improvements in carriages, scaffoldings, and ladders, which scaffoldings and ladders are used as carriages.

1600. Decimus J. Tripe, Commercial-road, East—Improvements in locks.

1601. John Fall, Chorlton-upon-Medlock, Manchester—Improvements in the treatment of certain oils.

1602. Nathan Pollard, Bowling, near Bradford—An improvement in machinery for drawing wool and other staple.

1603. Alfred V. Newton, 66 Chancery-lane—Improved machinery for printing.—(Communication.)

1604. George Mackay, Buckingham-street, Strand—Improvements in the manufacture of glass.—(Communication.)

1605. Moses Poole, Avenue-road, Regent's Park—An improved quartz-crushing, pulverizing, and amalgamating machine.—(Communication.)

1606. George A. Biddell, Ipswich—Improvements in apparatus for crushing grain, seeds, or pulse.

Recorded July 6.

1607. Thomas Newey, Garbett-street, Birmingham—Improvements in fastenings for wearing apparel.

1608. Peter Erard, Marseilles, France, and 4 South-street, Finsbury—Certain improvements in steam boilers.

1609. Peter A. Le Comte de Fontaine Moresu, 4 South-street, Finsbury—Improvements in typographical printing presses.—(Communication.)

1610. John Hood, Glasgow, and William Hood, same place—Improvements in the treatment or manufacture of ornamental fabrics.

Information as to any of these applications, and their progress, may be had on application to the Editor of this Journal.

DESIGNS FOR ARTICLES OF UTILITY.

Registered from 16th June to 13th July, 1853.

June 16th,	3477	T. J. Perry, Birmingham,—“Sash-fastener.”
20th,	3478	W. Duck and W. Wilson, London-road,—“High-pressure cock.”
25th,	3479	J. Parkes & Son, Birmingham,—“Sun-dial rule.”
July 1st,	3480	J. R. Murphy and P. Murphy, Dublin,—“Chair and Couch.”
—	3481	D. M'Leare and J. S. Oliver, Edinburgh,—“Bedstead-joint.”
—	3482	T. De la Rue and Co., Finsbury,—“Calendar.”
6th,	3483	J. Hutton, Burton-rescent,—“Pencil-case.”
7th,	3484	J. S. Stroud, Birmingham,—“Electric gas-burner.”
9th,	3485	F. Dent, Strand,—“Annular fountain-reservoir for liquid compasses.”
—	3486	J. Peakman, Birmingham,—“Shutter-fastener.”
13th,	3487	Barnard and Bishop, Norwich,—“Poultry feeding-trough.”

DESIGNS FOR ARTICLES OF UTILITY.

Provisionally Registered from 17th June to 13th July, 1853.

June 17th,	521	W. Redgrave, Croyley-green,—“Dress-preserver.”
July 13th,	522	W. Stretton, Hackney-road,—“Garden-engine.”

TO READERS AND CORRESPONDENTS.

M. R.—The matter is under consideration; but we are yet without the facts formerly mentioned.

L. G.—We shall take an early opportunity of setting this right.

H. H.—We will publish his sketch next month.

THE GREAT INDUSTRIAL EXHIBITION, 1853.

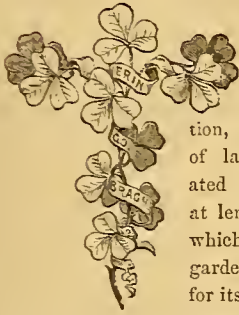

"The present generation finds itself the heir of a vast patrimony of science, and it must needs concern us to know the steps by which these possessions were acquired, and the documents by which they are secured to us and our heirs for ever."
—WISWELL.

THE Green Isle of the West, this year, boasts a new and an overpowering attraction, in addition to her many alluring charms of lake and mountain. To the well-appreciated beauties of her varied landscape, she has at length added a still more dazzling attribute, which, splendid though it is, is yet to be regarded less for its magnificence of to-day, than for its depth of promise for a bright and lengthened morrow.

Ireland, William Dargan, and the Dublin Exhibition, are the three names which go to make up the grand feature of the year 1853. It was a noble design, the conception of this hazaar of industry in the capital of a country so long torn by internal conflicts, and saddened by social miseries; it was a still nobler project, as the unaided undertaking of the children of the soil; but it was noblest of all in the fact, that a single Irish commoner—a veritable "captain of industry," who had toiled his way up from the base to the summit of his profession—should have ventured upon the entire responsibility of so vast an experiment. The early history of the scheme—in which the munificence of Mr. Dargan plays so prominent a part—has been already chronicled wherever a newspaper is produced. But it is nevertheless fitting, that at least an epitome of it should be placed on record in the pages of the *Practical Mechanic's Journal*.

For the last 25 years, the Royal Dublin Society has itself held triennial exhibitions of manufactures, the last of which occurred in 1850. Prior to the one for 1853 falling due—namely, in June, 1852, Mr. Dargan wrote to the Society as follows:—

"Mr. Dargan understanding that the year 1853 will be the year for holding the Triennial Exhibition of Manufactures of the Royal Dublin Society, and being desirous of giving such Exhibition a character of more than usual prominence, and to render it available for the manufactures of the three kingdoms, proposes to place the sum of twenty thousand pounds in the hands of a Special Executive Committee, on the following conditions:—

"1st. That a suitable building shall be erected on the lawn of the Royal Dublin Society.

"2nd. That the opening of the Exhibition shall not be later than June, 1853.

"3rd. That a special Executive Committee shall be nominated by three gentlemen on the part of Mr. Dargan, to be named by him, and by three gentlemen to be selected by the Council of the Royal Dublin Society from that body.

"4th. That Mr. Dargan shall have the nomination of the Chairman, Deputy Chairman, and of the Secretary of the Special Executive Committee.

"5th. That, at the termination of the Exhibition, the building shall be taken by Mr. Dargan, and shall become his property at a valuation by competent persons.

"6th. That if, after payment of all expenses, the proceeds of the Exhibition do not amount to £20,000, with interest thereon at 5 per cent., Mr. Dargan shall receive the proceeds, less all expenses incurred.

"If the proceeds, after payment of all expenses, amount to £20,000, with interest thereon at 5 per cent., Mr. Dargan is to receive £20,000, and interest at 5 per cent. If the proceeds, after payment of all expenses, exceed the sum of £20,000, with interest thereon at 5 per cent., the Executive Committee is to have the disposal of the surplus.

"The amount of the valuation of the building is to be considered as cash paid to Mr. Dargan."

On receiving this liberal proposal, the Society at once accepted it—a committee was formed, officials were appointed, and plans for the building were advertised for. The result was, that the executive committee, assisted by Messrs. Miller, Hemans, and Lanyon, selected the plans submitted by Mr. now Sir John Benson, the arrangements, as originally adopted, being afterwards modified by the addition of the northern and southern halls. In September, 1852, Mr. Dargan, finding that the anticipated wants of the Exhibition would far more than monopolise the whole of the allotted space, proposed a further advance of £6,000; and in February, 1853, he agreed to enlarge the building by additional erections round the front court and the agricultural exhibition yard, placing yet a further sum of £14,000, or a total aggregate of £40,000, at the disposal of the committee. Since this time, the works have been so modified and enlarged, that Mr. Dargan has actually expended upwards of £100,000 upon the undertaking.

William Dargan, the distinguished parent of the Great Industrial Exhibition, is a native of the county of Carlow, which district, however, he had quitted some time before he came at all prominently before the world in his professional character. His first public introduction may indeed be dated from the time of making the great Chester and Holyhead road under Telford, where he was associated with the present Sir John McNeill, then a pupil of Telford. This important undertaking necessarily drew forth Mr. Dargan's practical talents as an engineering constructor, and led to his being intrusted with many other great projects of that day. His first notable work in Ireland was the branch of the Grand Canal between Philipstown and Killeeghan; and he was afterwards selected as the best man for the Dublin and Howth road. But more gigantic enterprises now fell to his lot, and he commenced what may be called his really active career, by making the Dublin and Kingston Railway—the earliest of all the Irish lines, and one which, if rated by the standard of that day, must be admitted to be no ordinary work. His good work and punctual execution now fairly determined his position, and he became the contractor for the 40 miles of Ulster Canal, between Lough Erne and Belfast. After these performances came the Ulster, the Dublin and Drogheda, and the Great Southern and Western railways, in all of which he was most extensively concerned. The Great Southern and Western, and the Midland Great Western lines, are his most conspicuous performances; but as he has constructed nearly all the railways which Ireland possesses, having got through more than 600 miles of such work, an Irish railway history must be written before his constructive undertakings can be enumerated.

Mr. Dargan has now amassed a splendid fortune, and, along with it, an undying name for probity and professional skill. He is an agriculturist of some pretensions, and supports the character successfully at the various exhibition meetings of the country. He is a flax-grower, and has expended a large amount of capital in establishments for the manufacture of that staple fibre. He is a home sugar manufacturer, and Merrion Square contains some brilliant samples of what he has lent his aid to produce from the beet-root. He is a converter of peat bog, and his operations may soon be expected to tell upon the face of what have hitherto been Ireland's most neglected spots. Well does he deserve the highest regards of us all, and well may every visitor to the Exhibition look, with admiring approval, upon the statue of its founder. For "it is a noble object to test, by actual experiment, to what extent the ingenuity and skill of the nations of the earth have corresponded to the intentions of their Creator, and to improve the advantages which each country can offer the other in supplying the wants, and adding to the happiness of mankind."*

The general classification of the exhibited articles closely resembles that of the Exhibition of 1851; and although the building presents an external appearance very unlike its great prototype, the internal arrange-

ments forcibly recall the memories of the vast Glass Palace. As in it, a great feature is made of a central domed hall, the most conspicuous objects in which, are the Barou Marochetti's equestrian statue of the Queen; Jones' colossal statue of Mr. Dargan; Messrs. Ferguson and Miller's fire-clay or terra-cotta fountain; M. Andre's cast-iron fountain; Messrs. Chance's fixed dioptric lighthouse apparatus; with catadioptric zones on Fresnel's system; the jacquard looms of Messrs. Pim and Messrs. K. Atkinson & Co., Messrs. Todd, Burns, & Co., and Messrs. Keely and Leach; Messrs. Price's stately palm-tree case of candles; Mr. Grubb's equatorial telescope; and the respective organs of Messrs. Telford and Bevington in the end galleries. Messrs. Ferguson and Miller's fountain, 24 feet in height, is really a noble work. It was made at the Heathfield Works, near Glasgow, from the general design of Messrs. Baird and Thomson, the architects, the figures being by Mossman, a Glasgow sculptor, and the ornament by Mr. J. Steel. To the right of this central hall is a long range, in which are located the productions of the Zollverein, Prussia, France, Belgium, and the Indian collection—this is the south hall; and beyond it again are the fine arts, mediæval, and furniture halls. From the last, access is obtained to an almost interminable range of agricultural machinery, in the court-yard of the Royal Dublin Society's House; and a circular sweep from this portion contains locomotive mechanism, and models of various kinds, and brings us into another straight range filled with stained glass, and a splendid array of carriages. Hence a passage brings us back into the main body of the building, on the side of the north hall, before which we pass chemical, naval, and railway machinery, and arrive at the north hall, amongst iron and general hardware, manufactures from silk and wool, and from mineral substances. Outside this again, on the extreme north, is a long and narrower range filled with machinery in motion.

In this section, the main object is a beautifully finished 50 horse high-pressure direct-action double steam-engine, ordered from and built by Messrs. Fairbairn of Manchester, for driving a main shaft, 240 feet in length, carried on pedestal pillars along the centre of the division. The whole of this mechanism is deserving of the highest praise, as an example of good, well-finished work. Close to Mr. Fairbairn's engines, and standing across the hall, is a double-cylinder beam-engine, constructed by Messrs. Grendon & Co. of Drogheda, on the duplex expansive principle of Mr. M'Naught. It is a fair piece of good substantial work, but without any pretensions to finish. The same makers have also a small four-horse engine on the elevated end of the machinery court, where it was placed for driving the printing machine of the *Illustrated News*. A portable three-horse engine is also exhibited by Mr. G. M. Miller, the superintending engineer of the Great Southern and Western Railway. It is fitted up with a boiler, and works a three-throw water-pump, the whole being an example of what is in actual use on the railway. The workmanship is excellent. Various other steam-engines are also exhibited by Mr. Shekleton of Dundalk, the Irish Engineering Company, Simpson and Shipton, Mr. C. Lawrence, Mr. R. Turner, and Messrs. James Watt & Co. Mr. E. Rourke of Carlow has also undertaken the practical illustration of the hydraulic ram, as adapted for raising water to the tops of houses by the action of a neighbouring streamlet. The little apparatus is in working trim, so that the value of this ingenious contrivance may be easily comprehended. The *Illustrated News* printing machine is not at work, but its place is supplied by Messrs. Gunn and Cameron's *Exhibition Expositor* machine, which is hard at work, printing a respectably illustrated newspaper, entirely devoted to critical and descriptive notices of the Exhibition itself. Of the other printing machinery in this quarter, the double-acting platten machine of Messrs. Courtney and Stephens is curious, from the fact, that the platten itself is stationary—the type table having the requisite vertical traverse for giving the impression, in addition to the usual horizontal traverse for inking and feeding.

A most attractive feature in the "machinery in motion," is to be

found in the steam confection apparatus of Messrs. Graham, Lemon, and Co. The rapid wholesale way in which the sweetmeats are made, constantly interests large bodies of onlookers. A similar attraction also exists at the end of the court, where the "potter's wheel" of the Messrs. Kerr of Worcester initiates general observers into the mysteries of the porcelain manufacture, for which Worcester is so celebrated. Mr. Fairbairn's great shaft actuates a long file of machines on each side. Amongst these are some good planing machines, lathes, and drills, by Sharp, Stewart, & Co. of Manchester, and Messrs. Lewis of the same place. Messrs. M. Samuelson & Co. of Hull have a capital specimen of a hydrostatic seed-oil press, with a double kettle for heating the seed, and a table engine for working the press. The whole of the machinery here is excellently arranged, and forms an excellent school for those who visit the "machinery in motion" in the character of inquiring students.

In "agricultural and horticultural machines," the Exhibition is particularly rich. All the principal English makers are in strong force, and many very excellent machines of Irish manufacture are mingled with them. The rival reapers, and Mr. Samuelson's digger, as engraved in our last number, are great sources of attraction. A model of a farmstead by Mr. Adair of Bellegrave, Queen's county, and modelled by Mr. John Anderson of Dublin, is a most interesting contribution. It represents the offices for 1,000 acres, with accommodation for 20 horses and 300 head of cattle, the machinery being actuated by an eight-horse steam-engine. The plans of concentrated farm-yards of Mr. D. Watson of Newtownsandes, Kerry, are equally interesting.

Amongst thrashing machines, that by the Rev. Mr. Willison of Dundonald involves the most recent novelty. In arranging this machine, Mr. Willison started with the principle, that a blow of a certain momentum must be given to the grain to produce the desired effect, this momentum, in the case of a revolving body, being measured by the space passed through by the beater in a given time. Thus, in the instance of two drums, the one 3 and the other 1½ feet in diameter, the smaller one would require to revolve at double the speed of the greater, to give the same effect. In examining many varieties of existing machines, he found the thrashing speeds ranged between very wide extremes—the surface of some drums moving at the rate of 90 feet per second, whilst others were as low as 50 feet—showing that there is much more of guesswork than of calculation in their construction.

From these observations, Mr. Willison was induced to believe that a speed of 60 feet would answer well in a satisfactorily-built machine; and he further concluded, that by giving a reciprocal blow—that is, striking the grain on both sides—as good an effect would be secured at a speed of only 30 feet. But the difficulty was, how to apply the blow to the best advantage, as, in the common machine, the stroke is given at a great expense of power. The straw is struck at right angles, and by far the greater part of the force is lost in bending the straw.

But this is not all, for loss further occurs from the thrashed or cleared straw remaining in contact with the striking spars of the drum; and when the straw is long, as every farm labourer knows, the machine is, for this reason, often rendered almost immoveable. The first point was met, in the new invention, by using two flat beaters, slightly crossing each other's circle of rotation; and the second, by the introduction of straw-clearers. An error was at first committed in making the striking edges of the beaters too thick or blunt; but experiment soon showed that these parts cannot be too sharp, provided they do not actually cut the straw.

The action was now satisfactory; but the machine was very heavy to drive. The crossing of the striking edges was at this time 5 inches, and examination showed that, at certain points of revolution, both edges touched the straw at once, thus causing a double bend, and pressing the straw in opposite directions. The blades were then narrowed from 14 to 10 inches, and the crossing was gradually reduced to 1 inch. This alteration lightened the resistance very much, whilst the thrashing

MESSRS EDW^d T. BELLHOUSE & CO ENGINEERS,
MANCHESTER.

Fig. 1.

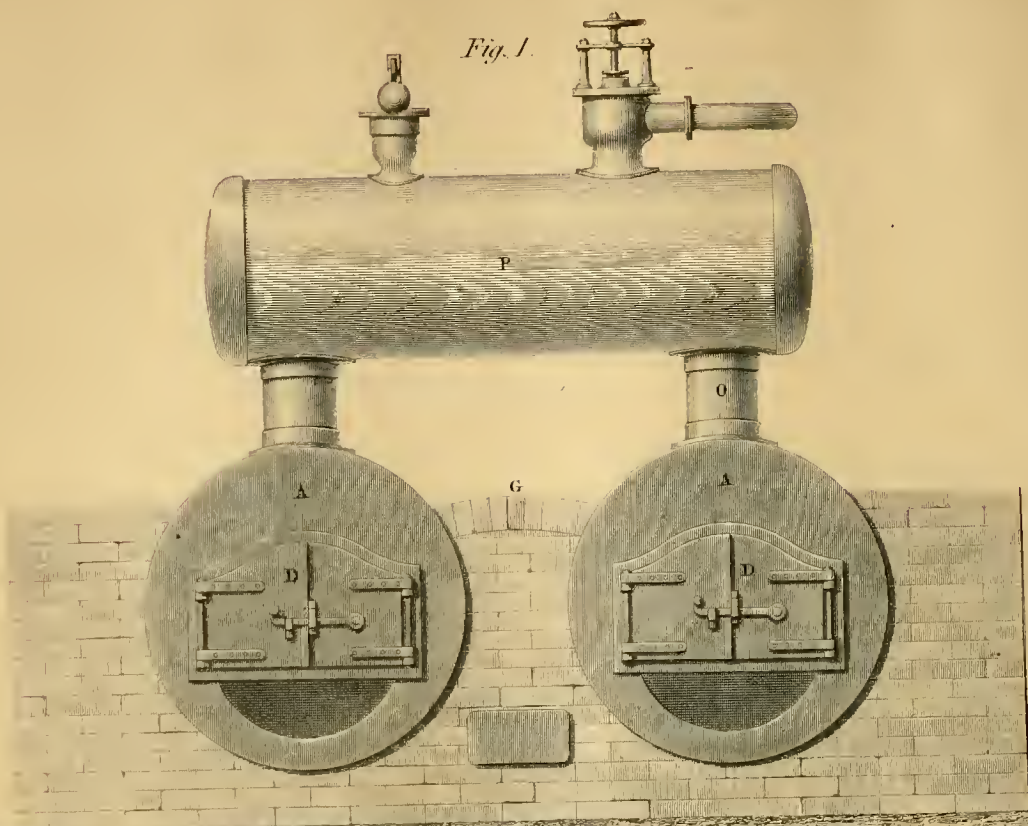
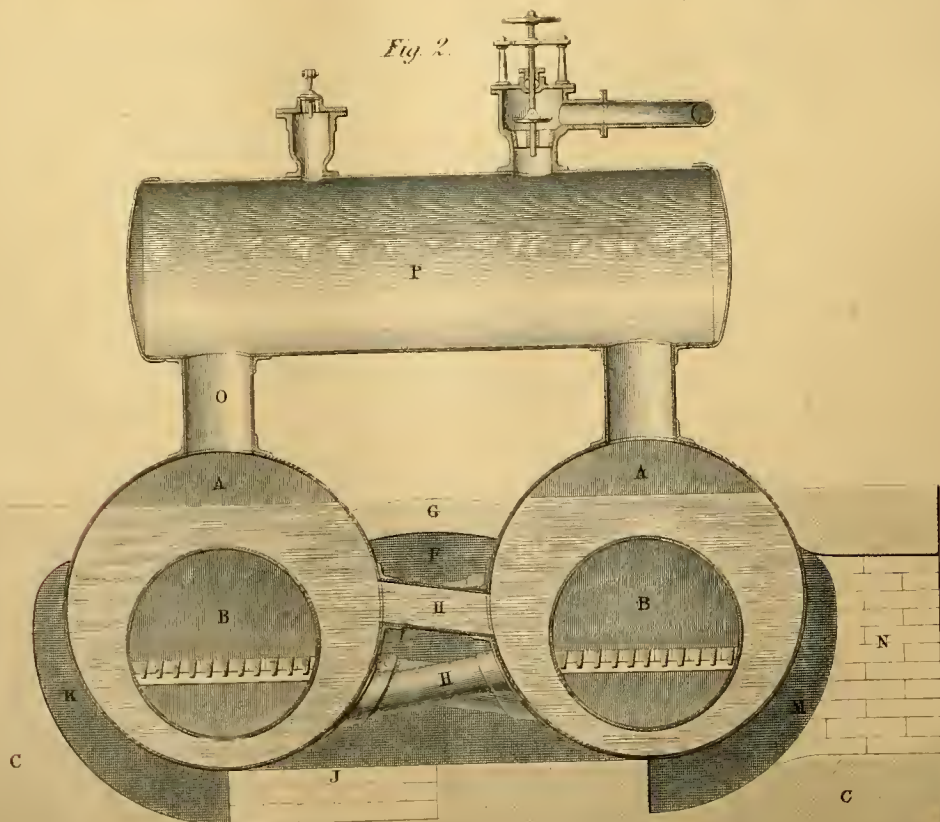

Fig. 2.



SCALE

2' 6" 0"
Ins

5

10
Feet

effect was improved; for, as all grain projects from the straw, it admits of being struck in a line parallel with the straw; and the nearer to this line the stroke can be applied, by so much is power saved. But as the straw must be struck more or less, it is necessary that it should be left free at one end, to fly off when the stroke is given, in order to prevent the occurrence of any rubbing action; and the effect of this is, that the grain, which is the heavier mass, does not retreat so fast as the straw, and it is thereby placed in a better position to be struck off by the beaters. The exhibited machine was made by Mr. McCartney, the well-known Ayrshire machinist. It is fully illustrated and described in another part of the present pages.

The carriage division, as we have already stated, makes a very brilliant display. Chief amongst the examples in this class is the dress-coach, built by Messrs. J. Hutton & Sons, of Dublin, for her Majesty. It is a finely-modelled and particularly well-finished specimen of the art. The national Irish car figures under every conceivable variety. That by Messrs. Killinger, besides being a departure from the common form, as regards the passengers' seats, has a spice of the "Hansom" about it, the driver being perched upon a light seat at the very rear of the vehicle, whilst the reins stretch forward over the centre of the car body, between the two rows of occupants. Each side is divided, to form two distinct seats—an arrangement much more comfortable than the open side. Mr. Bianconi's "fly mail car" is interesting for many reasons—and not the least from its being the carriage employed by the eminent mail contractor, for conveying mails and passengers in nineteen Irish counties. But we must defer our general details until another month supplies us with further space.

Every one who has paid but slight attention to the progress of scientific invention and research, must have been often reminded how much real discoveries are choked up by hollow assumptions—how many errors must be submitted to profound reasoning, before the honest truth can be elicited. And this continually becomes more striking as new departments arise, and as science develops new capabilities; for history is, indeed, breathless in keeping up with fact; and our rapid transitions from the base of yesterday's formation to the elaborated structure of to-day, leaves but little time for the expansion of those large thoughts which lead to just discrimination. But a practically illustrative exhibition like the present, in giving us whatever there may be of encouraging signs in the passing times, furnishes, not sentiments, but facts—not mere fictions of opinion, but substantial results. In such a collection, then, the observer may calmly deliberate, weigh, examine, and consider what is practicable and what is not; for he is in a field where he can easily separate what has been said, from what really and truly is. He will see in it vivid "illustrations of the difference between the philosophy of thorns and the philosophy of fruit—the philosophy of words and the philosophy of works"—and he enabled, in most things, to compute the proportion between the means and the end. Above all, let him endeavour to attain a true conception of the mission of this great school, remembering that "knowledge is a blessing to the soul; and not merely a toy for amusement, or a tool for gain."

THE LAW OF PATENTS FOR INVENTIONS IN PRUSSIA.

The law of Prussia with respect to patents is regulated by an order of the Cabinet, dated the 27th September, 1815, and by certain explanatory additions subsequently issued, a summary of which is now given, except so far as relates merely to the process of obtaining a patent.

By the letter of the law, only subjects of Prussia can obtain patents, but, in practice, foreigners are allowed to apply to the Minister of the Interior, either directly or through their ambassadors; and when it appears that the applicant would be entitled, if a subject, to the patent solicited, he may acquire the right of citizenship in the prescribed manner, or he may transfer his rights to a subject of Prussia, in whose name the patent can be taken out.

Patents are granted not only for original inventions and improvements made in Prussia, but also for imported inventions and improvements.

In applying for the patent, an exact description of the invention, either in writing, or by models and designs, and, if possible, in all these ways, must be sent in. A patent will not be granted for less than six months, or for a longer period than fifteen years; the usual terms, however, are for five, six, or eight years. Generally, it extends to the whole monarchy, but this is optional with the Finance Minister.

The patent will be invalidated if the invention is not put into operation within six months of the grant. This article of the law is indulgently construed by the government; but it is necessary to lay before it some proof that the invention was put into execution within the time limited, otherwise the patent will be lost.

A patentee will not be allowed to prohibit any other person who has previously made a similar invention or improvement to that patented, from making use of his invention.

The patentee of a process of manufacture may prohibit the use of his process by others within the kingdom; but he cannot prohibit the manufacture of similar articles by another process; nor can he prohibit the importation of such articles, whether made by the patented process or not.

The patentee of a machine or mechanical contrivance may prohibit its use by other persons, whether it shall have been made within the country or abroad. Nevertheless the Customs' department shall have no control over the importation of machines similar to those patented, the patentee being left to enforce his rights in a court of justice.

A patent cannot be obtained for the mere application of a contrivance or process of construction already known, to purposes where to it has not previously been applied, this not being deemed a new invention; nor can a patent be obtained for a contrivance or process known to have been already applied to similar purposes.

When an invention has been described in published works, either native or foreign, or when models of it have been publicly exhibited in Prussia, it ceases to be new, and cannot be patented. Even when the description was published, and the model exhibited by the inventor himself, still he will be precluded from obtaining a patent subsequently.

Patents for imported inventions are only allowed when they have not become known in the country by means of published works or other means; if so known it will be no ground for a patent that the applicant is the first importer and user of the invention.

Patent rights may be transferred from one person to another.

The examination of the application for a patent belongs to the Board of Trade, and is limited to an inquiry into the novelty and originality of the invention, without reference to its utility, except in the case where it professes to be an improvement on previous contrivances or processes. If the claim is allowed, the applicant will be informed in what the novelty and originality of the invention were conceived to consist, and whether it is patentable in respect of all its parts, or only in respect of some, or simply in respect of their combination, the parts separately not being new and original. The invention is then described in the official journals of government. Any one desiring information as to whether he will be guilty of an invasion of the patent by proceeding in a certain manner, may apply to the Finance Minister on the subject.

If it should appear that the invention is destitute of novelty and originality, the patent is vitiated, and this will be set forth in the grant itself. The government will not undertake to preserve any of the secrets of the patentee.

BELLHOUSE'S "TWIN" STEAM BOILER.

(Illustrated by Plate 134.)

The firm of Edward T. Bellhouse & Co., of the Eagle Foundry, Manchester, whose enterprising exertions in bringing forward valuable novelties in engineering construction have already drawn from us many approving remarks, is now introducing a new arrangement of steam boiler, which promises to be an important acquisition to the employers of mechanical power. The boiler is of the "twin" kind—that is, two distinct steam generators are combined together, to work as one boiler, the two being placed side by side, with a central tubular chamber between them. It is this intermediate flue which forms the distinguishing feature of the contrivance, the smoke and heated air from the two generators being passed through this chamber, on their way from their respective furnaces, to the chimney.

According to one modification of the patentee's plans, the two boilers are cylindrical, with internal furnaces, from which the smoke passes right through the central flue of each boiler, and out at the back end, into a main cross flue, connecting the two boiler flues. Here the two gaseous currents join, and the combined current then returns to the furnace end of the boilers, through the intermediate chamber of tubes.

This chamber may either be built up of brickwork or of boiler plate, just as the boiler is fixed, or independent; and it is formed by placing the two boilers wide enough asunder, to leave the required space between them, the top and bottom of the space being covered in by any suitable arrangement. Such central chamber is filled up with a series of short transverse tubes, forming cross water-way connections between the two boilers. In this way the return current imparts its heat to an extended water-tube surface, and on the arrival of the current at the front end of the boiler, it diverges to one side—to the left, for example—and passes through a suitable cross flue beneath the boiler on that side. This conducts the current into an external longitudinal flue, surrounding a great portion of the outer side and bottom of the boiler, and running back again to the further end of the boiler. From this point the current enters another bottom cross flue, opening into a corresponding external longitudinal flue, along the right-hand boiler, which flue finally opens into the chimney flue at the furnace end.

Our Plate, 134, with its subsidiary wood engravings, will make the plans pretty clear. Fig. 1, on the plate, is a front end elevation of the duplex boiler, as erected in brickwork; fig. 2 is a transverse vertical section corresponding, the section being taken through the two furnaces, the brickwork and flues, and the overhead steam-chest; fig. 3, the wood engraving in the body of the description, is a longitudinal section of the arrangement, taken through the intermediate chamber, the external flues, waterways,

Fig. 3.

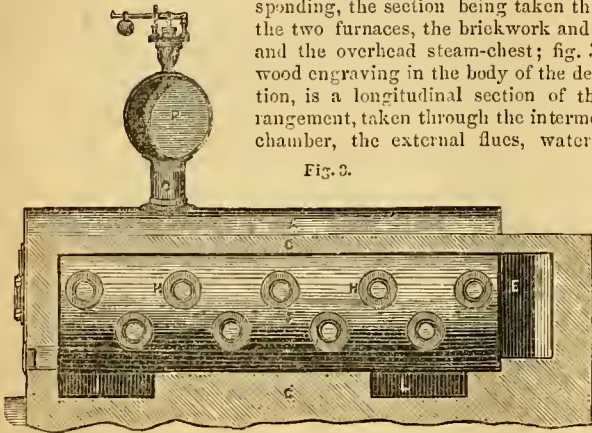

and the steam-chest; and fig. 4 is a sectional plan to correspond. Both these latter views are drawn to a scale of one-half the corresponding views in the plate.

The two boilers or generators, A, are of the common cylindrical, tubular class, with internal furnaces and flues, B, running right through them

Fig. 4.

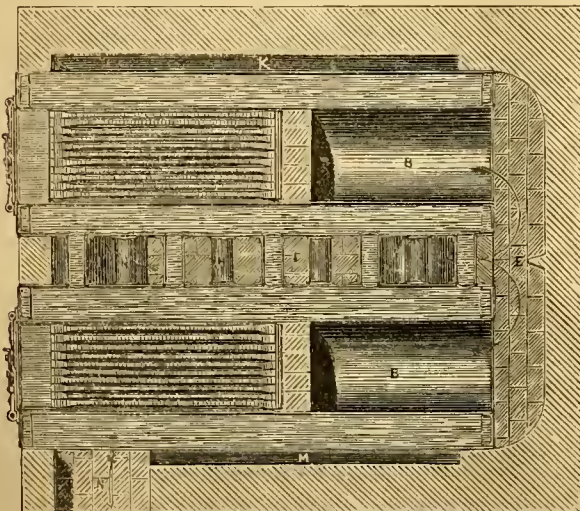

from end to end. They are set in a brick foundation, C, suitable flues being formed in the walls of brickwork, to answer for the special arrangements of the combination. Each boiler is fired separately, through the usual end furnace doors, D, and the gaseous products pass off from each set of furnace bars in the direction of the arrows, the two currents meeting and forming into one, in the main end transverse flue, E, in the brickwork. This combined current then turns again towards the front of

the boiler, passing directly through the intermediate chamber of tubes, R, which chamber is formed on its two walls by the contiguous surfaces of the boilers, A, and on its top and bottom by an overhead arch, G, of brickwork, and the mass of the brickwork base. The short tubes, U, which cross the space between the two boilers, are water-spaces, being open at each end into the respective boilers, beneath the water-line therein; thus, the heated current being intercepted by this arrangement of tubular water-spaces, as it traverses the intermediate chamber, imparts its heat to an extended heating area. The tubes are disposed in two rows, sloping at reversed angles from one boiler to the other, to aid the internal circulation and the passing away of the steam. This central thoroughfare, R, then conveys the current of heat and gaseous products to the front end of the boiler, where it diverges, as at T, descending into a short transverse flue, J, passing beneath the generator on that side. This conveys the current into the external longitudinal flue, K, surrounding and covering in a great portion of the outer side and bottom of that generator; and this flue, K, then forms the duct for the traverse of the current a second time to the far end of the boilers. Having reached this part, the current next enters another bottom transverse flue, L, beneath the back end of the intermediate chamber or cell, R, and through this short flue the current enters the external longitudinal flue, M, of the opposite generator, precisely similar to the before-mentioned external flue, K. In this way, this latter generator is well heated externally, like the former one; and as the flue runs all the way back to the furnace end of the boiler, the current finally passes off along it, and through the short branch, X, to the chimney. With a boiler so contrived, the whole of the large flue area in the centre of the boiler is well exposed to the direct heat of the furnaces; and the greatest possible portion of the external boiler surface is similarly acted upon, and heated after the current leaves the central passage, whilst the possession of this central chamber admits of the perfect commingling of the gaseous products of combustion, and the obtaining of a greatly increased heating area, from the arrangement of the pipes therein. The two generators, thus equally and uniformly heated, furnish each its own supply of steam, through the overhead vertical pipes, O, to the horizontal steam-chest, P. Any number of such generators may, of course, be combined together, securing all the advantages of a 1 intermediate flue-cell between each.

Messrs. Bellhouse have also another plan, where the boiler is independent, the combined furnace returning along the centre tube chamber, and then passing down beneath the front end of one boiler, and proceeding to the chimney-flue direct. The flue arrangement, and the direction of the currents, may be variously modified, to take advantage of the essential feature of the central chamber tubes.

HARTIN'S CYLINDER WATER-METER.

(Illustrated by Plate 135.)

This meter, which is an American invention, is a simple arrangement of a cylinder and piston, fitted up with slide-valves, for the ingress and exit of the water to be measured; the cylinder, which is the actual measuring vessel, being filled at each stroke of the piston, after which the slide-valve is reversed, when the water escapes, and a fresh supply is admitted on the opposite side of the piston. This action, therefore, keeps up a reciprocal movement of the piston, and the registration of the measured fluid is effected by a counter attached to the valve-spiudle, and actuated by the slide movement.

Fig. 1, on Plate 135, is a sectional elevation of the meter complete; fig. 2 is a corresponding end view of the meter; and fig. 3 is a plan. At A is a wooden or metal base-frame for supporting the cylinder and working parts of the apparatus. The cylinder, B, is carried by the two vertical supporting brackets, C, and is fitted with a slide-valve, D, and piston, E, screwed on to the piston-rod, F. This rod passes through a stuffing-box, G, in each end of the measuring cylinder, and has a short adjustable arm, H, screwed to it near its outer extremity by a pinching screw, I. The lower end of this arm is fitted with a stud-pin, J, which works in the longitudinal slotted rod, K. This rod slides in the fixed bearings, L, which are bolted to the main vertical portion of the framing. The outer extremity of the slotted rod is connected by a short link, M, with the lower end of the vertical weighted tumbling lever, N, working on a fixed stud centre, O. The upper end of this lever is guided in its movements by the segmental guide-plates, P, which are carried by a pillar, Q, bolted to the main framing. The slide, D, is contained in the chamber, R, which is furnished with an inlet-pipe, S, and the spindle of the slide is jointed at T, to one end of the adjustable connecting-rod, U. The opposite end of this rod is jointed to the segmentally-slotted plate, V, in which works a stud-pin, W, fitted into the lever. The slot on this seg-

WALTER METLER,

W. HARTIN, PATENTEE, NEW YORK.

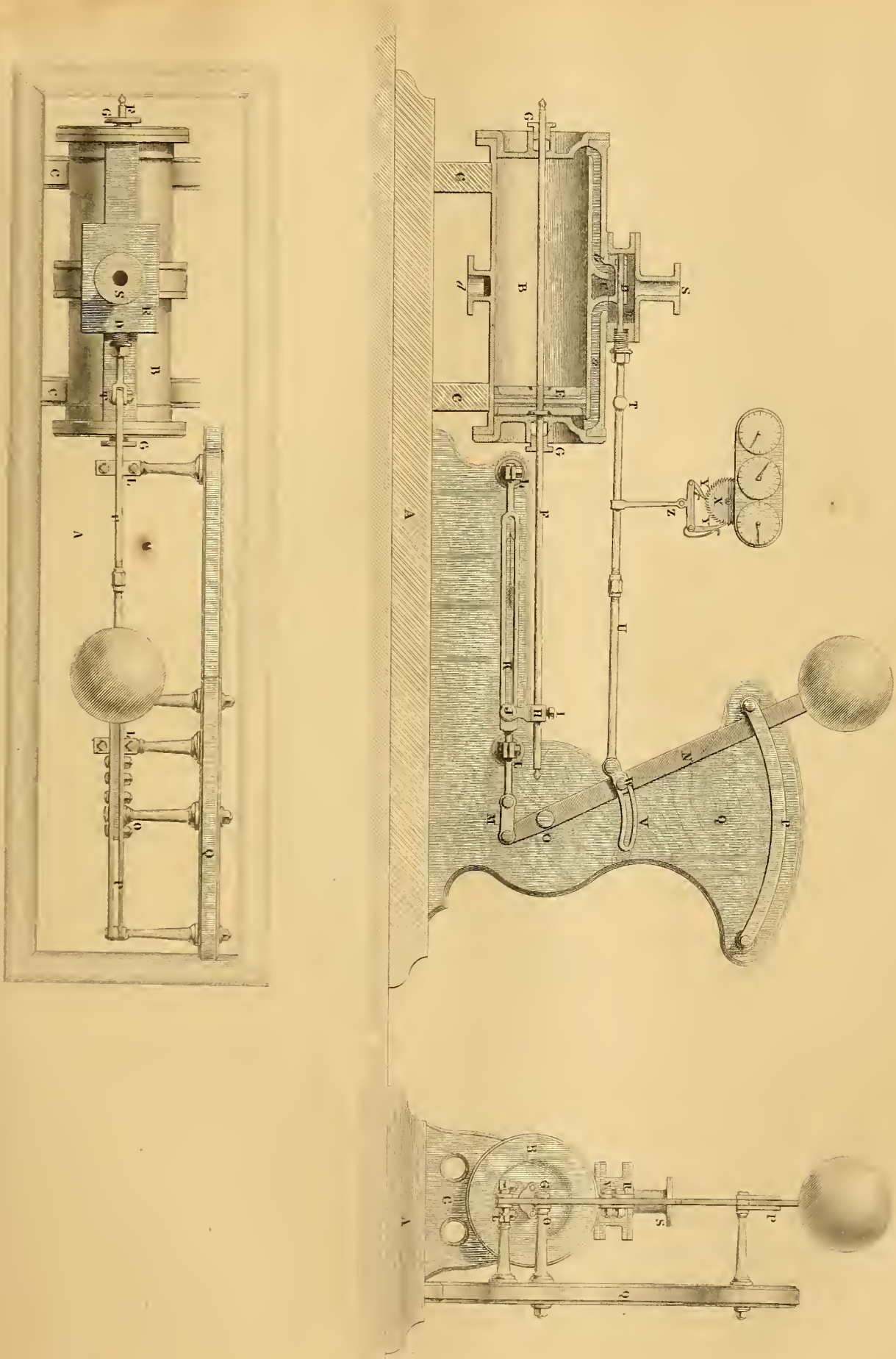

W. Johnson, Patent Office,
477 Broadway, New York, N.Y.

1880



mental plate is rather shorter than the traverse of the pin in the lever, so that, when the lever is caused to oscillate or vibrate, a certain amount of traverse is given to the slide, *d*. The movement of the lever, *x*, is effected by the traverse of the stud-pin in the slotted rod, *k*, the slot in this rod being shorter than the stroke of the piston; and consequently, when the pin arrives at the end of the slot, the further traverse of the piston slides the rod, *k*, in its bearings, and thereby turns the lever, *x*, on its fixed centre, *o*. The registration of the fluid-flow is effected by the ratchet-wheel, *x*, actuated at every stroke of the slide by the palls, *r*, fitted to the T piece, *z*, which is secured to the connecting-rod of the valve-spindle.

In measuring fluids by this meter, the matter to be measured enters by the inlet-pipe, *s*, into the chamber, *n*, whence it passes along the open port, *a*, into the corresponding end of the cylinder, *b*. The pressure of the fluid forces the piston to the opposite end of the cylinder, thereby

causing the pin, *j*, to traverse along the slotted rod, *k*, and move it in the direction of the arrow. This movement of the rod reverses the lever, *x*, which effects the movement of the slide, *d*, by means of the stud-pin, *w*, and slotted link, *v*. By this means, the port, *b*, is opened suddenly, and the fluid is allowed to enter the opposite end of the cylinder, thereby forcing the piston back again, and consequently expelling the fluid which was contained above the piston; this fluid escapes by the egress port, *c*, which is now in communication with the inlet thoroughfare, *a*. A hollow zone or belt is cast round the cylinder, and forms the outlet for the fluid which pours into the source-pipe through the branch-pipe, *d*, cast in one piece with the cylinder. By fitting a moveable false bottom or end to the cylinder, so as to be capable of adjustment by an external screw or other movement, the capacity of the cylinder may be regulated to the greatest nicety, by simply screwing or setting in or out the internal false bottom.

BROWN'S STEAM HAMMER.

This hammer, the invention of Mr. W. Brown of Chapel Hall, near Glasgow, involves several ingenuities of improvement upon the well-known tool of Mr. Nasmyth. It is suitable for all the varieties of work to which such tools are usually applied; but, as used for forging, it consists of a pair of opposite or reverse side standards, set vertically in the same plane, their upper contiguous edges being set so as to afford a vertical guide for the hammer or ram motion. This hammer consists of a long narrow cylinder, bored at its upper end, and closed in at the top by a blank flange, whilst it is grooved vertically down each side, to slide on

guide-pieces on the standards, and its lower unhored end has attached to it the hammer face. A portion of this long cylinder is slotted longitudinally through from side to side, and through this slot, which must be fully equal to the greatest traverse of the hammer, a horizontal bar is passed, the two ends of this bar being secured to the framing. To the centre of this bar is attached the lower end of a long

bar, of cylindrical section, and turned to fit the cylinder's bore, being set to project up into the cylinder, its upper end terminating just within the cylinder's closed end, when the hammer is down. The upper end of this bar, or fixed piston as it may be termed, is fitted with an elastic ring as a packing. And this piston is bored through longitudinally, nearly from end to end; but its lower end is closed, and the supplying steam-pipe enters this bore laterally at the lower end, so that the actuating steam is thus conducted up the bore, and out at the clear open end of the piston, to act against the blank flange end of the cylinder. By this arrangement, as the driving steam is supplied through the fixed piston, it presses against the closed cylinder end or top, and thus raises the cylinder in its slides, and carries up the hammer face. Then, when the steam is allowed to exhaust back through the piston on a change of the valves, the hammer falls and works in the usual manner. The steam is supplied through an equilibrium or balanced piston valve, so contrived by proportioning the respective diameters of the piston and its rod, that the steam pressure shall itself open the steam inlet to the hammer cylinder, when the valve is unacted upon by the proper mechanical movement. The spindle of this piston valve is jointed to a short crank-lever, fast on a long vertical spindle, which is set to oscillate in top and bottom bearings on

the frame, and carries an opposite or reverse lever, adjustable at any given height upon the spindle, whilst its free end has a pulley arranged to bear against an incline or cam-piece on the hammer cylinder. The lower end of this long spindle carries a short pin or stop-piece, capable of engagement with the hooked end of a small spring detent, which always bears upon the stop; and this spring detent is connected with a second long vertical spindle, capable of a slight lateral traverse to the extent of the detent itself, and carried upon a fixed stud centre by a short lever arm. This

lateral traversing spindle is actuated periodically, by an oscillating catch hung on a stud in the side of the cylinder, and kept turned upwards by a very slight spring. Then, when the steam has elevated the hammer to the required height, the incline on the cylinder shuts off the steam, and opens the exhaust port, by pressing upon the pulley lever arm on the oscillating spindle working

the valve. The hammer then falls, and the sudden stop of the falling mass causes the momentum of the oscillating catch on the cylinder to overcome its supporting or antagonistic spring, and presses the heel of the catch against the lateral traversing spindle. This motion then releases the spring detent from the stop on the oscillating valve-actuating spindle, and the steam pressure therefore again opens the induction valve for the succeeding elevating stroke. By this plan the steam is prevented from gaining access to the cylinder during the hammer's fall, whilst it is again admitted at the precise moment of intended elevation, whatever may be the amount of traverse or the momentum of the blow. The rate of working is modified by a stop valve on the steam-pipe, and a similar valve on the exhaust-pipe softens the fall of the hammer more or less as required, and the amount of hammer traverse is regulated by adjusting the pulley lever on the oscillating valve spindle, high or low, so as to be acted on sooner or later by the incline on the cylinder.

Our engravings represent a hammer, slightly modified from the foregoing description, the working apparatus being overhung to one side. Fig. 1 is a front view of the hammer, 1-36th real size; fig. 2 is a side elevation at right angles to fig. 1, the upper portion of the working mechanism being represented in vertical section; and fig. 3

FIG 1.

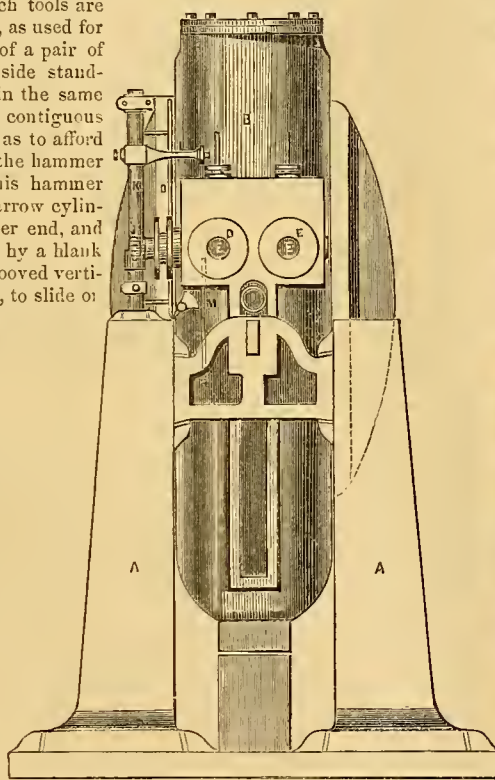
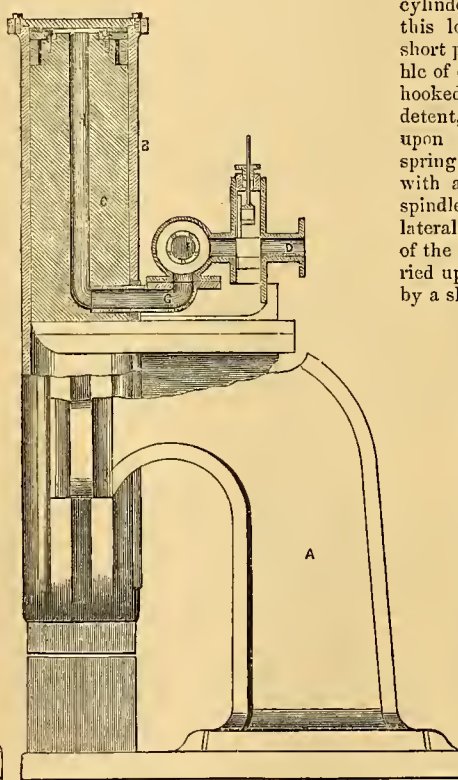
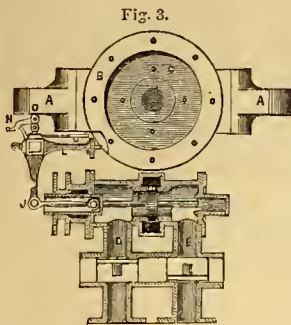

FIG 2.



is a horizontal section of the main gearing. The frame consists of the two standards, A, each having overhanging sides, and supporting flanges to support and guide the steam cylinder, n, set over the solid stationary piston-rod, c. The steam enters the cylinder through the port, d, and exhausts by the corresponding passage, e; each of these passages having an adjustable slide-valve, so that both the steam admission and exhaust may be easily regulated. From the piston-valve, f, the steam passes through the branch-pipe, g, and thus enters the side of the fixed piston-rod, through the centre of which it passes by the thoroughfare, h, so as to reach the cylinder end, above the piston packing. The



balanced valve-spindle is linked at j, to a crank on the spindle, k, carrying the second lever, l, the pulley of which bears upon the incline, m, on the steam cylinder. The bottom detent apparatus is at n, and the second long spindle is at o; p being the oscillating catch on the steam cylinder.

The additional valve on the exhaust pipe, enables the hammerman to vary the rate and power of the blows quite irrespective of the height to which the hammer may be raised, and the addition of a small discharge cock upon the steam-pipe, at any part above the piston-valve, serves to carry the water of condensation clear away from the work, an important advantage which no other hammer possesses. The contrivance is well suited for working boring tools for mining purposes; and it will also answer for pumping, and for giving motion to various kinds of machinery, in addition to its legitimate office of hammering.

MECHANIC'S LIBRARY.

- Architecture of France, Domestic, folio, 63s., cloth. Cluton.
- Designs, Suggestions in, 4to, 16s., cloth. Luke Limner.
- Dublin Exhibition, Illustrated Catalogue of, royal 4to, 10s., cloth, gilt.
- Encyclopaedia Britannica, 8th edition (in 21 vols.), Vol. 2, 4to, cloth. 21s.
- Industrial Movement in Ireland, 7s. 6d., cloth. J. F. Macguire, M.P.
- Locks, On the Construction of, 1s. 6d. Tomlinson.
- Masting and Rigging of Ships, 1s. 6d. R. Kipping.
- Photography, Practice of, crown 8vo., 4s. 6d., cloth. P. H. Delamotte.
- Timber Merchant's Assistant, 32mo, 1s. 6d., cloth. W. H. Wyeth.

YORSTON'S RAILWAY POINT KEY AND SIGNAL.

We have recently seen, on the Belfast and Ballymena Railway, a useful little safety contrivance, contrived by Mr. Alexander Yorston, the locomotive engineer of the line, for insuring the safe management of the points or switches. In this apparatus, a short shaft is laid beneath the line of rails in a horizontal direction, and at right angles to the points, this shaft being capable of traversing in suitable guides, and having at each line of shifting-rail a pair of lugs, or projections, standing up, one on each side of the rail, so as to hold the sliding and switch rails from opening on the passage of a train. One projecting end of this shaft has upon it a curved lever, carrying at its upper end a signal disc, which answers at the same time as a weight to keep the shaft so set, that its lugs will always be vertical to retain the rails, this effect being accomplished by the bearing of the weight over to one side, in consequence of the bend near the lower end of the lever. A lamp may also be attached to this disc lever. By this arrangement,

Fig. 1.

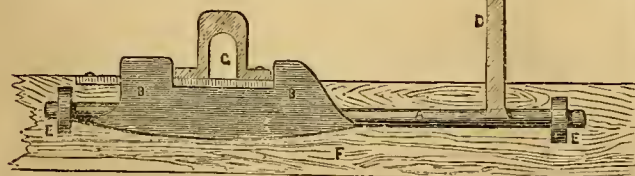
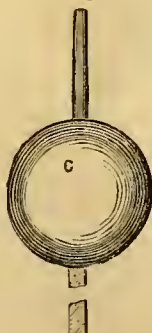

whenever the lever stands upright, the lugs take up a similar position and hold the rails, so that the points cannot possibly spring, neither

can the signal lever be elevated to indicate "safety" or closed points when the points are open, or partially open, as the inside lug is left long enough to catch the under side of the rail under such circumstances, and thus hold the shaft from turning, and the lever from being raised. Hence, the engine-driver always knows how the points are, when at a considerable distance from them, and he is independent of chance missetting of the points by the attendant.

Fig. 1 of our engravings is a front elevation of the apparatus, with the signal up and points closed; fig. 2 is a corresponding end elevation; and fig. 3 shows the signal down and the points open; a is the shaft laid beneath the points, and carrying the projections, b—embracing the rails or points—the inside lug being left long enough to catch the under side of the rails when the points are open. The weighted signal disc is at c, on the bent lever, d. The shaft works in two eyes, e, on the sleeper, f, carrying the points. The portion, g, in fig. 3, shows the section of the points; a lamp may either be applied to the signal, or the attendant may give the signal by holding up the lamp when the main line is right; or by putting the lamp on the ground, facing the train when it is going into the siding, leaving both hands at liberty to hold the points.

Fig. 2.

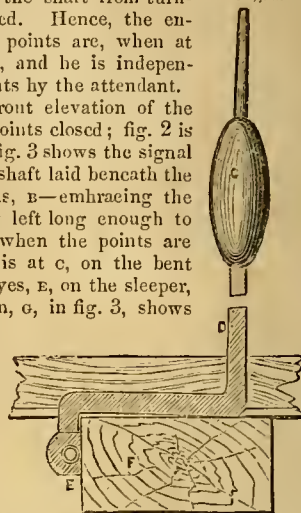

By the adoption of this invention, Mr. Yorston provides security for the main line, as it is impossible for the tongue or switch-rail to spring open whilst a train passes, even at the highest rate of running. Besides this, the signal will always give the driver timely warning when the points man is going to turn him into the siding, without leaving room for any doubt on the subject; and this is a most essential feature, when

Fig. 3.

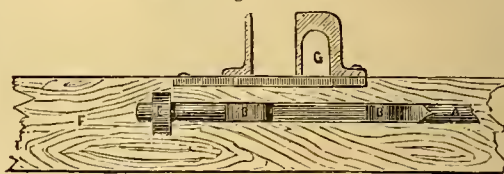

it is remembered that the attendant sometimes inadvertently turns the points the wrong way. With the key and signal, this mistake cannot possibly occur, seeing that the man must put the signal down before he can open the points; and then the driver, finding the signal off, will at once slacken speed, or stop if necessary, before he reaches the points. The plan is also very suitable for roadside stations, where the porter or station-master can always see from the platform if his points are all right, and, with the key and signal, they require no holding. We believe the plan is quickly spreading to many other lines of railway.

RECENT PATENTS.

THRASHING MACHINERY.

REV. A. WILLISON, *Manse of Dundonald, Ayrshire.*—*Patent dated Oct. 2, 1852.*

In the common thrashing machine, hitherto in use, for separating grain of various kinds from the straw, the essential feature of the separating or beating apparatus consists of a rotatory cylinder, usually known as the "drum," such drum being a cylinder, either open or enclosed, and fitted with projecting beaters, or striking arms or vanes, placed longitudinally upon the cylinder, in relation to the axis thereof. Such a revolving drum is contrived, so that its projecting arms shall strike the grain or substance undergoing the thrashing action, as it passes through or between the rollers. Mr. Willison's invention relates—

1st. To the substitution for the drum of a species of flattened beater, revolving on a horizontal or other shaft, and giving the grain two distinct strokes, or thrashing blows, at each revolution of the shaft. This beater is placed, like the common drum, immediately behind the rollers of the thrashing machine, and with its shaft set either above or below the horizontal line of entry, or passage, between the rollers, so as to give grain either upward or downward strokes. This beater may be made of various forms; but its general feature is that of a flat rectangular hoard or vane, attached to a shaft, as delineated in figs. 2 and 3, in our engravings annexed. But it may also be made duplex, so as to give four strokes, instead of two, at each revolution.

2d. To the arrangement of thrashing machines, wherein skeleton cylinders or drums, or plain rollers, are placed immediately behind the beater just described, and in close contact with such heater, for the purpose of preventing the latter from being entangled with the issuing straw. Such cylinders or rollers are termed the straw-clearers. They

Fig. 1.

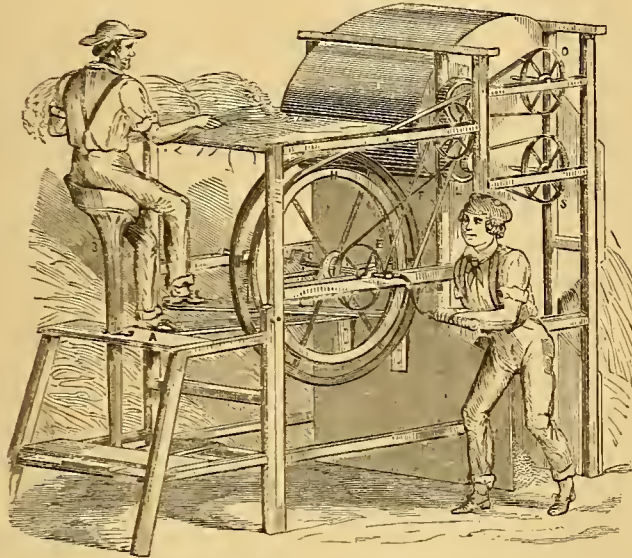

may be made of various forms; but it is preferred to be cylindrical, of the same length as the beaters, and revolving in the same direction.

3d. To the arrangement of thrashing machines, wherein one beater, with its corresponding straw-clearer, is placed above the horizontal line of traverse of the unthrashed grain into the machine, between the feed-rollers thereof and another beater, with its straw-clearer beneath the said

Fig. 2.

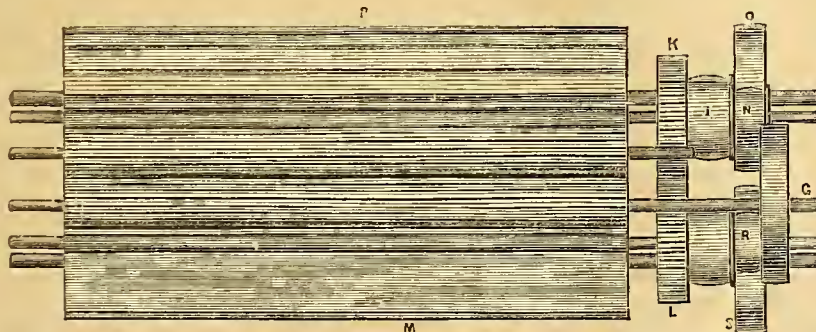

fluted feed-roller spindle, c. The same shaft also carries a large pulley, n, from which an open band passes to a pulley, r, on the end of the shaft of the upper beater, j; this shaft having upon it a spur-wheel, k, gearing with a similar wheel, l, on the shaft of the lower beater, m. In this way the two beaters simultaneously revolve at the same rate, but in reverse directions. The shaft of the upper beater has also a pulley, x, upon it, with an open band passing from it to the pulley, o, on the end of the shaft of the large upper straw-clearing roller or cylinder, p. The lower roller, q, is similarly driven by a pulley, r, on the bottom beater shaft, by a band passing to the pulley, s, on the roller shaft.

Thus, as the grain is fed in upon the upper platform, it is drawn forward by the grooved rollers, c, and carried directly into contact with the pair of beaters, j m; and as these beaters revolve at a high rate, they alternately strike the grain upwards and downwards. Each edge of the beaters crosses the horizontal line of traverse of the straw to a short extent (variable at pleasure), as it comes round, in its progress of revolution; so that, as the unthrashed grain passes along, the grain is most effectually separated or struck off from the straw, by the alternate and opposed actions of the beater edges. The heaters are keyed on their respective shafts, so as to work constantly at right angles to each other, this position being retained by gearing the beater shafts together with equal toothed-wheels. Hence the two beaters work into each other, as

horizontal line. By this plan, whilst the straw-clearers are so placed that they are kept apart from each other, to allow the thrashed straw to pass off between them, the striking edges of the revolving heaters are made to cross above and below the said horizontal line, in order to strike off the grain. When two beaters are used in this manner, they are so geared together as to work at right angles to each other—that is, their respective shafts are geared together in such manner, that the four striking edges on the two beaters shall strike the grain alternately. By this contrivance, the unthrashed grain, as it passes between the rollers, is struck both upwards and downwards alternately, before passing off between the straw-clearers.

This thrashing machine may be actuated in various ways; but, for the purpose of adapting it to manual or human labour, the arrangement represented in fig. 1 is adopted. In that plan, a fly-wheel shaft, with a double crank thereon, is employed as the first motion, such shaft being worked by the pressure of the feet of the attendant upon a pair of treadles, connected to the two cranks. With such an arrangement, the attendant who feeds the machine with the unthrashed grain may actuate it at the same time, the motion being conveyed from a large band pulley on the crank shaft to the moving details of the machine. By this means a single attendant accomplishes the whole process of thrashing; but he may be assisted, if necessary, by a second hand turning a winch on the end of the crank shaft. The separation of the grain from the straw is thus effected more economically, and with a less expenditure of power than hitherto, by reason of the unthrashed grain being struck on both sides alternately.

Fig 1 is a perspective elevation of one form of the thrashing machine, as arranged to be worked by human power; fig. 2 is a front elevation of the beating apparatus detached, together with the actuating and connecting gearing thereof; and fig. 3 is a corresponding side view of the same.

The framing of the machine is an ordinary rectangular erection, having a platform, a, at one end, with an adjustable seat, b, for an attendant, who feeds the unthrashed grain into the machine, and at the same time aids the thrashing action with his feet. He accomplishes the latter result by working the two treadles, c, which are linked to a pair of cranks on the first motion winch-shaft, d, which is mainly turned by a separate attendant. This first motion shaft carries a small pulley, e, from which a cross band, f, passes to a pulley on the end of the lower

Fig. 3.

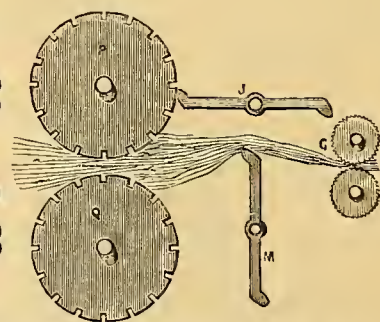

it were, like wheel-teeth, and subject the grain to a most severe thrashing action in passing through. As the grain is detached, it falls down, clear of the machinery, into its proper receptacle, at the bottom of the casing of the machine; whilst the cleared straw passes off to the back of the machine, between the two constantly revolving rollers, p q.

ROTATORY ENGINES.

C. HARFORD, Windsor.—Patent dated Nov. 25, 1852.

This ingenious engine is directly founded upon that of Mr. Galloway, as patented by him in 1846, the essential improvement being in the mode of admitting the steam to the acting cells or chambers. Mr. Harford admits the steam from the interior of a revolving trunnion, and through a series of radial ports or thoroughfares, formed in the cylinder ends, an annular piece of metal being fitted within such trunnion, with portions of this ring cut away at the localities corresponding with the radial ports, for the steam to pass through. This internal ring is capable of lateral expansion by the longitudinal pressure of two disc plates, the circumferential edges of which are beveled off, or conical, and made to fit into the ring, the latter being also beveled, to correspond. By this contrivance, the pressure of the actuating steam is made to move the cylinder,

piston, and shaft, slightly in the direction of the engine's axis, whenever the steam is let on; and this action opens all the induction ports, and simultaneously closes all the exhaust ports, with the exception of those in connection with that part of the cylinder with which the piston is in contact. Such of the chambers as are not in contact with the piston are filled with high-pressure steam, to act as a spring, or elastic equipoise, for retaining the piston firm up against the working side of the cylinder.

Fig. 1 is a longitudinal section of the improved engine; and fig. 2 is an end elevation, at right angles to fig. 1, but with the front end cover-plate removed, portions of the details being shown in section.

The entire engine is carried upon the open rectangular framing, A,

Fig. 1.

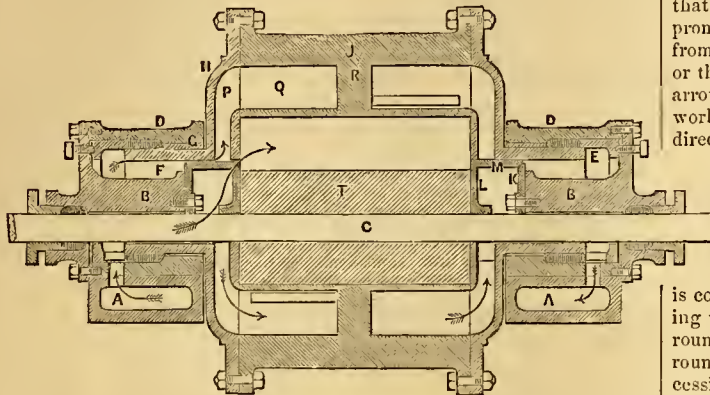

cast hollow, to serve as steam and exhaust ways. On this, as a foundation, are bolted down the two fixed pedestal trunnion-bearings, B, in which the whole of the moving parts are supported. Each of these pedestals has an external stuffing-box, through which the main first motion, or engine shaft, C, is passed. Each pedestal has also cast upon it a circular disc, set eccentrically as regards the axial line of the main shaft, and having a ring of bolts set round its periphery, and entered into the edge of an external annular casing, D, which forms the outer shell of the main rotatory stuffing-box of the engine. Inside this piece, D, is a brass gland, E, capable of being set up by a set screw, to act upon the stuffing-box packing, between the inside of the outer shell and the exterior of the hollow revolving trunnion, F. This forms the main stuffing-box,

Fig. 2.

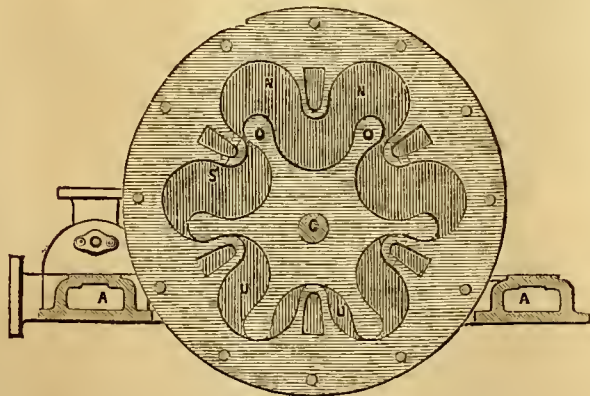

the bottom end, as it were, being produced by a shoulder in the shell, D, at which part is inserted a piece of brass, G, as a bearing surface. The trunnion is cast in one piece with the end disc-plate, H, of the engine; and the details being exactly the same on each side of the engine, the central portion of the steam chamber or cylinder, J, is bolted up between these two end discs, the working steam chamber being thus made up of these three details, connected by annular flanges and bolts. The inner face end of the piece, B, has bolted to it a brass disc, K, cut out on one side, to admit the main shaft. A similar disc, L, is also set up against the end face of the steam piston; and the two contiguous circumferential edges of these discs are beveled, or shaped conically, to correspond to an expanding brass ring, M. This ring is cut away on its lower side, to afford the necessary steam-ways, whilst its upper solid side blocks up

the upper ports, leading to the steam chamber. Unlike Galloway's engine, this engine is contrived so that both its cylinder and piston shall revolve. In other respects, the internal cells, as at X, of the chamber, and the corresponding rounded projections, O, of the piston, are arranged precisely the same as in Galloway's engine. In this instance there are six cells, and consequently six radial ports in connection with them. Each of the radial ports opens, at the entrance end, into the interior of the trunnion, P, outside the ring, M; and after radiating outwards in the line of the disc's plane, the port terminates in a bend at R, in correspondence with a thoroughfare, Q, in the steam chamber, terminated by a central division, R. From this thoroughfare, a lateral branch, as at S, forms the communication between it and each cell of the chamber, the only difference, as regards the two opposite sides of the engine, being, that these lateral ports are set in reverse directions on the sides of the prominences forming the cells. In this way steam may be admitted from either side, accordingly as the engine is to revolve in one direction or the other, the ports being steam and exhaust ways by turns. The arrows on the left of fig. 1, indicate the direction of the passage of the working steam from the boiler, when the engine is revolving in the direction pointed out in fig. 2; and, similarly, the arrows on the right of fig. 1, point out the exhaust course of the used steam. The boiler is in connection with the base frame, A, and the hollow in such frame conducts the influx working steam up through a port above, and thence into the open outer end of the trunnion. Here its pressure, acting upon the end of the piston, T, causes it to move slightly upon the shaft, C, to which it is connected by a key. This movement necessarily removes the expanding wedge pressure from the ring piece, M, so as to leave a space all round it for the passage of the working steam. The steam then passes round about this ring, and enters the cells of the working chamber successively. This causes a peculiar differential eccentric revolution of both the piston and its chamber, owing to the steam pressure in the constantly widening or expanding cells, V, as the prominences of the piston work through them. Whilst this is going on, the steam from each cell is successively exhausted, as each thoroughfare comes round to the cut-out portion of the brass ring on that side; for the steam pressure from the opposite side, which has slackened the ring, M, has correspondingly expanded the opposite ring, by the lateral wedge action of the discs, so that the upper solid side of the ring is pressed against the converging ends of the steam ports, leaving only those open for exhaustion where the ring is cut away for the purpose. Hence the escape steam passes off, through the trunnion on that side, to the thoroughfare on the base frame. Whilst the engine is working, the upper ports, as T, are all kept full of the steam at the high working pressure, so as to balance and resist the working strain from beneath.

PRESERVATION OF SHIPS' BOTTOMS.

J. E. Cook, *Greenock*.—Patent dated Dec. 29, 1852.

Mr. Cook's invention relates to the manufacture, application, and use of a novel composition or mixture for coating the bottoms of ships and boats, and other surfaces exposed to fouling, oxidation, and decay. Such composition is made up of the following ingredients:—Gum shell-lac, gum seed-lac, gum gamboge, gum arabic, gum benzoin, red-lead, white oxide of zinc, and French verdigris, all mixed or dissolved in spirits of wine, or wood spirit, of a strength of about 60 degrees over proof. The proportions of these several matters which are prepared, are—shell-lac, two pounds weight; seed-lac, half a pound; gamboge, half a pound; gum arabic, half a pound; gum benzoin, half a pound; red-lead, one pound; spirits of wine, or wood spirit, one gallon. In making this mixture, the several gums are first dissolved in the spiritous ingredients, to form a rich varnish. Red-lead is then added in a mortar, by degrees. The vessel's bottom, or other surface to be coated and protected, is first well cleansed, and then this composition is brushed on like paint. When dry, a second coating is similarly laid on, and allowed to harden like the first. The surface so treated is then brushed over again with a second composition, based upon the one already described. In making up this second composition, there is added one pound and a half of white oxide of zinc, and one pound and a half of French verdigris. The verdigris is previously made up into a strong solution with spirits of wine; and whilst the red-lead of the first-mentioned composition and the white oxide of zinc are added, a measure of eight gills of the verdigris solution is mixed up with the mass, by degrees, in a mortar. Two coatings of this secondary composition are laid on the previously treated surface, and this completes the operation.

This system of treatment answers well for all exposed surfaces, whether iron or wood, and the composition is especially serviceable for pro-

protecting the bottoms of ships. It effectually resists damp, and protects iron from oxidation, whilst it secures either iron or wooden ships from fouling in a very perfect manner.

This composition is rapidly coming into use; for it is a most effectual preservative, whilst it contains no ingredient at all injurious to the coated surface.

BLEACHING JUTE.

J. CAPPER, *Old Brompton*, and T. J. WATSON, *Fulham Road*.
Patent dated Jan. 12, 1853.

In their process of purifying, attenuating, and bleaching jute, and other vegetable fibres, the patentees first boil or scald them in a chemical solution, composed of any of the following substances, namely: soda, carbonate of soda, chloride of soda, muriate of soda, oxide and hydrate of soda, carbonate of potassa, chloride of potassa, bitartrate of potassa, nitrate of potassa, oxide of potassa, hydrate and hydrated oxide of potassa, carbonate of ammonia, nitrate of ammonia, sulphate of magnesia. These chemicals are used in the following proportions:—One hundred and forty pounds of any of them are dissolved in from half a tun to two tuns of water for every ton of jute, or other vegetable fibre, to be acted upon. In this solution, which is called the steeping bath, is placed the jute or other vegetable fibre, to boil or scald for two hours; and at the expiration of that time it is removed, and suspended upon laths or ropes, to drain off the water. It is then transferred into a bleaching bath, prepared by the admixture of 560 pounds of chloride of lime, soda, or magnesia, in two tuns of cold water for every ton of jute, or other vegetable fibre, intended to be bleached. In this solution the material is allowed to remain for twenty-four hours; it is then withdrawn, washed in water, and dried, and is then ready for the market. With some portions, however, when greater purity is required, after removing it from the bleaching bath, it is steeped for two hours in an acidulated bath, composed of either sulphuric or muriatic acid, in the proportion of two pounds of acid to one tun of cold water. An acidulated bath may be employed as a steeping bath, instead of the various chemicals previously alluded to, composed of either muriatic, fluoric, or sulphuric acids, in the proportion of sixty-five pounds of either acid, mixed with two tuns of water for every ton of jute, or other vegetable fibre, to be acted upon. In this bath the fibrous material is steeped for twenty-four hours, then drained, and placed in the bleaching bath, and treated as before described.

The jute, or other vegetable fibre, after removal from the steeping bath, may be suspended upon laths or rods, in a room prepared for the purpose, exposed to the action of chlorine of gas for six hours previous to its being placed in the bleaching bath. The jute, when exposed to the action of the gas, should be thoroughly damp.

The steeping bath may be employed without heat, but in that case the jute will require to be steeped for twenty-four hours, when it is withdrawn, drained, and placed in the bleaching bath for another twenty-four hours, and is subsequently washed either with cold water or the acid solution, and dried as before described.

DRAIN-PIPES.

G. G. MACKAY, *Grangemouth Coal Company, Scotland*.—Patent dated February 16, 1853.

According to this invention, earthenware drain-pipes are made in two distinct halves or segments, divided longitudinally along the centre, the junction edges being "stepped," so as to overlap each other slightly,

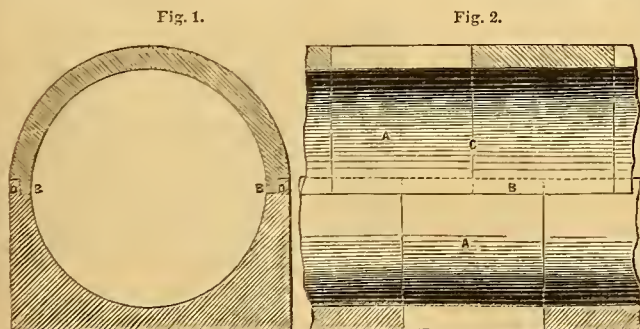

and form a secure joint. Segmental bricks may be used for a similar purpose instead of half pipes, and the transverse sectional area may be of any required shape. By the adoption of this plan of construction, a great saving of labour is effected in the necessary excavations for the

drains, as well as in laying the pipes therein, whilst it enables drains of large size to be laid very expeditiously.

Fig. 1 represents a transverse section of a circular drain with a flat sole, as constructed according to these improvements; and fig. 2 is a longitudinal section of a portion of a pipe corresponding. Each pipe is made up of a series of segmental pieces, *A*; a line of which is used for the upper longitudinal halves, and a line for the lower halves, the longitudinal junction being along the line, *n* *v*. The vertical lines, *c*, formed by the end abutting edges of the individual segments of the upper and lower tier, are so set, as regards each other, that they shall "break bond" with each other, each line of junction in the upper half or section being opposed to a solid part in the lower line. By this means a strong and well-connected pipe is produced. The longitudinal junction edges are formed with shoulders or stepped surfaces, as at *b*, *d*, in the transverse section, fig. 1, and this prevents any lateral dislocation of the individual details. The drain, represented in fig. 1, is precisely the same as regards its plan of build and construction. For all drains of large size, this arrangement answers most completely; for the system of connection is a strong one, whilst the larger of the drains is unencumbered with huge masses of earthenware, which are difficult to lay, and liable to fracture.

GAS-BURNERS.

J. H. JOHNSON, *London and Glasgow*.—Patent dated Feb. 3, 1853.

This invention, communicated by M. Marmonty of Paris to the British patentee, embodies both an improved form of burner, and a new system of regulating the gaseous flow thereto by means of a diaphragm valve, placed either within the tube which conveys the gas to the burner, or within the burner itself.

Figs. 1 and 2 of the engravings represent a vertical section and corresponding plan of the improved burner, drawn to a scale of three times the natural size. The ordinary Manchester burner is composed, as is well known, of a short cast-iron tube, closed at one end, and having two converging cylindrical perforations formed in it for the egress of the gas. The modification consists simply in the employment of four perforations, *b*, in place of only two, as commonly used. By this arrangement, the gas is thoroughly distributed through the four apertures, thereby taking up a sufficiently large quantity of air for effecting its perfect and total combustion, and, consequently, giving a much more powerful and brilliant light for a certain quantity of gas.

Fig. 3 is a vertical section of this improved burner, with the tube and regulator attached, and drawn full size. Fig. 4 is a vertical section of a burner with regulator attached, slightly different in form. Fig. 5 is an enlarged vertical section of the regulator detached; and fig. 6 is a plan of the same, with the diaphragm removed. The burner, *A*, is fitted in the ordinary manner to the upper end of the tube, *b*, which is screwed internally at its lower extremity to receive the regulator. This regulator consists of a small metal plug, *d*, fitted with a disc, *f*, of caoutchouc, or other suitable flexible material. This disc overhangs the four apertures, *g*, *g*, in the upper portion of the plug, through which the gas passes on its way to the burner. The action of this regulator is as follows: supposing the gas to be at its ordinary pressure, the diaphragm will not be sensibly acted upon; but should the pressure increase to an undue extent, the impinging of the gas against the under side of the diaphragm, *f*, will elevate it, and cause it to come in contact either with the sides of the small chamber in which it is enclosed, or with the mouth of the tube, *s*, thereby reducing the supply until the pressure diminishes, when the elasticity of the diaphragm will cause it to assume its normal position. This diaphragm may be made either slightly bent downwards, as shown at fig. 5, or perfectly horizontal.

Fig. 1.

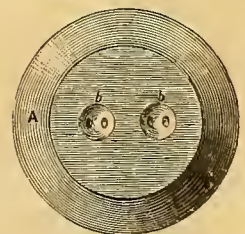
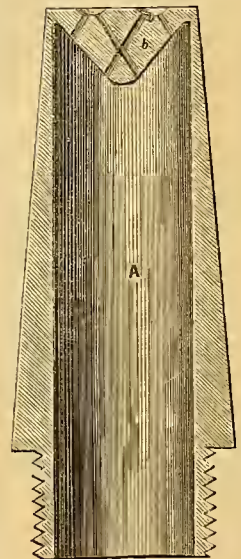

Fig. 2.

Fig. 7 represents the application of a guard or cap, *A*, to a burner, to prevent the entrance of dust, or other foreign matter, into the perfora-

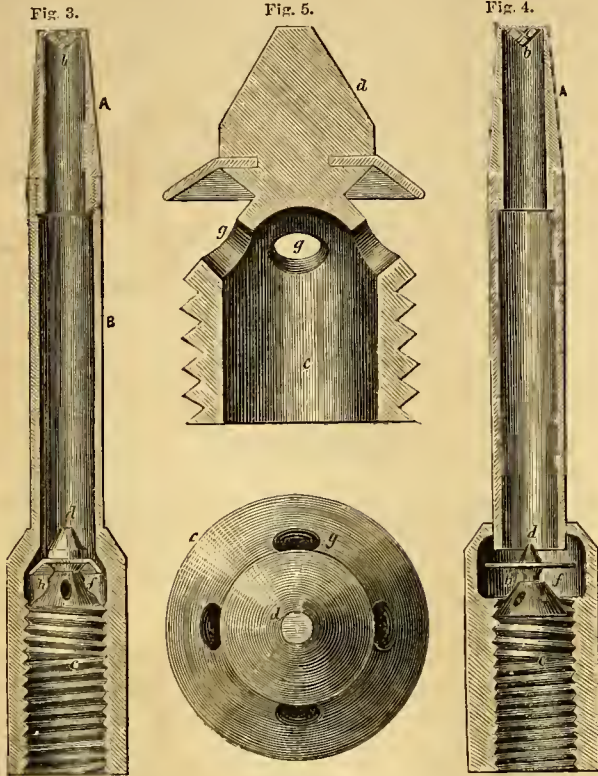

Fig. 6.

tions of the burner when not in use. The diaphragm, *g*, of the regulator, *c*, consists of a disc of very thin and pliable metal, such as tinfoil. It

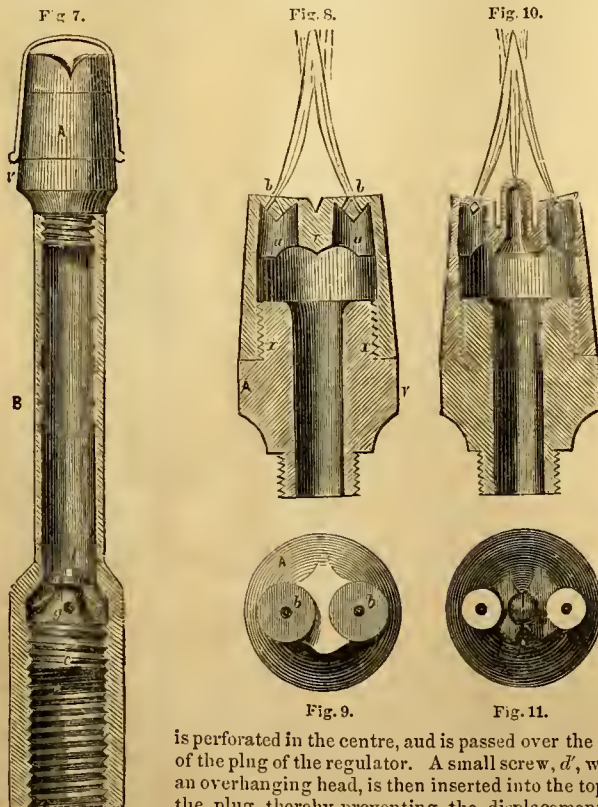

Fig. 9.

Fig. 11.

is perforated in the centre, and is passed over the top of the plug of the regulator. A small screw, *d*, with an overhanging head, is then inserted into the top of the plug, thereby preventing the displacement of

the disc. Fig. 8 is a vertical section of another arrangement of burner, somewhat similar to the burner first described; and fig. 9 is a plan of the upper part of the burner, which is divided into two smaller burners, *b b*, the faces of each being inclined slightly towards each other, in order that the two jets of gas may converge, and form one large flame. The interior of the burner has two small chambers, *u u*, drilled obliquely within it, such chambers forming the holes of the two small burners, *b b*, and thus constituting one large combined burner. The central angular portion of the burner between the two chambers, serves to direct the current of gas evenly into each, without materially destroying its velocity or pressure. Figs. 10 and 11 represent, in section and plan, a burner of a similar construction, with the exception of the application of a third jet, of the ordinary "bat's wing" construction, which is interposed between the burners—making, in all, three converging jets of gas.

PYROLIGNEOUS ACID RETORTS.

EDWARD MUCKLOW, *Bury*.—*Patent dated Dec. 28, 1852.*

Mr. Mucklow's retorts are especially designed for use in the process of distilling pyroligneous acid from spent dyewoods, sawdust, tanners' bark, chips, and other refuse, or disintegrated ligneous substances; but they are also applicable, with but slight variation, for the distillation of the like products from billets, branches, or logs of wood. The retort may be either cylindrical or rectangular, and it is set perpendicularly. The fire may be either applied externally or internally. If the fire is to be applied externally, the retort is closed at both ends; and in the centre of the same, a hollow perforated cylinder, or a cylinder of cones, is placed, leaving a space between it and the outside of the retort. In this space the wood is placed. If the wood is in small particles, as sawdust or spent dyewood, this space should not much exceed 6 or 8 inches, in order to secure the perfect charring of the wood all through; but if the retort is intended to distil from billets of wood, which do not lie so closely, the space may be increased, according to the nature of the material under operation.

The perforated cylinder may be formed in a variety of ways, but the method which the patentee prefers, especially in distilling sawdust and spent dyewood, is to construct it by placing a series of conical metal or earthenware rings, one above the other—these rings being provided with small projections, in order to keep them at a little distance from each other. This peculiar mode of construction prevents the possibility of the perforations, or openings, becoming clogged or closed by the small particles of wood. In the central space, which is enclosed by the perforated cylinder, may be placed pipes, through which cold water is caused to circulate. The wood is placed in the retort in a moist state, and the top of the retort is then closed and "luted" down. Upon heat being applied to the exterior of the retort, the vapours evolved from the wood pass through the perforations, or between the conical rings, into the inner space, and are partially condensed, by coming into contact with the cold-water pipes. The product thus obtained falls to the bottom of the cylinder, and passes off through a pipe, provided for that purpose; or the whole of the condensing process may be carried on outside the retort. If the fire is to be applied internally, a fire-flue must extend up the centre of the retort. Around this flue is the space for the wood, enclosed by the perforated cylinder or the conical rings, which must be inverted, and outside is the condensing space, enclosed by the exterior of the retort. The principal feature of the invention is, that the vapours arising from the destructive distillation of the wood do not come into contact with the heated surface of the retort, but pass off immediately into a comparatively cool space; and thus the great consequent waste is prevented, and much more acid, and considerably more naphtha or pyroxilic spirit, is obtained. The annexed figures represent both of the above arrangements, drawn to a scale of about 1½ inch to a foot.

Fig. 1.

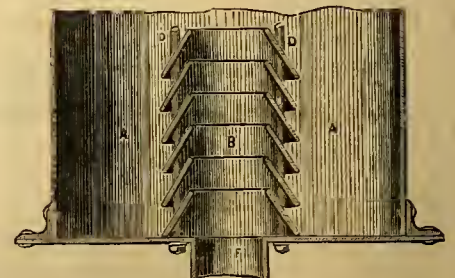

Fig. 1 represents a vertical section of the improved retort, enclosing the space, *A*, in which the wood is placed. At *B* are a series of conical rings, placed one upon the other, and kept apart by means of small projections, *c*, shown also in the detached views of one of the rings, fig. 2. These rings are held steady, and kept in their places, by means of the vertical rods, *D*,

passing through holes in the rings, which form a perforated cylinder, and enclose a central space, E. At F is the pipe through which the acid passes off to the condenser. It will be seen that, owing to the conical form and peculiar arrangement of the rings, B, it is impossible for the spaces between them to become clogged or choked with the sawdust; and, consequently, upon heat being applied to the exterior of the retort, the vapour that arises immediately passes upwards, between the rings, into the space, E, whence it is conveyed away through the pipe, F, and thus it does not become deteriorated or wasted, as heretofore, by coming into contact with the heated surface of the retort. Fig. 3 is a vertical section of the retort, as arranged for the internal application of the fire. A is the fire-flue, extending up the centre of the retort, and B is the wood space surrounding the same, and enclosed by the conical rings, C, which in this instance are inverted. These rings are supported and kept asunder in the same manner as in the preceding arrangement. D is the condensing

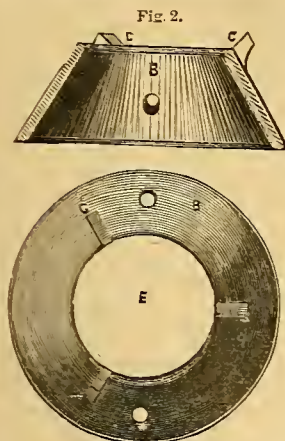
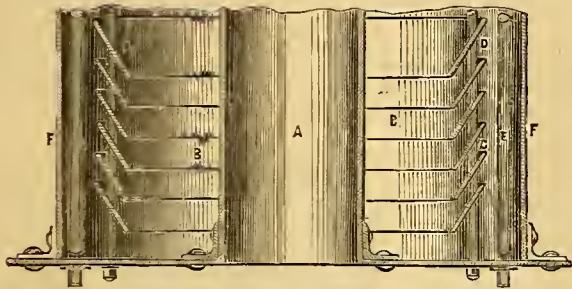

Fig. 2.

space are inverted. These rings are supported and kept asunder in the same manner as in the preceding arrangement. D is the condensing

Fig. 3.



space, and E the cold-water pipes, enclosed by the exterior case of the retort, F. At G is the pipe through which the acid passes off.

RAILWAY WHEELS.

T. C. RYLEY and E. EVANS, Haigh Foundry, Wigan.
Patent dated January 17, 1853.

Messrs. Ryley & Evans' improvements, although principally relating to the wrought-iron wheels of railway plant, are also applicable in the construction of fly-wheels, drums, and other articles of the wheel class. Such wrought-iron wheels have hitherto been formed by first roughly forging or rolling the ends of a bar of sufficient length into the requisite segmental form. The bar is then bent into a triangular form, so that the two extremities come together, forming a segment of the nave, whilst the middle part of the bar forms a segmental portion or arc of the inner rim of the required wheel. A sufficient number of these segments thus

Fig. 1.



Fig. 2.



formed, being suitably arranged and heated in a furnace, the whole is welded into a solid wheel. In forming or constructing wrought-iron wheels in the above manner, a very great amount of time and labour was necessarily expended in filing or otherwise fitting the said segmental parts to form the nave, so as to make a sufficiently close and accurate joint previous to welding. And the present improvements consist, first, in so rolling the spoke iron, that the ends which are to form the nave shall be of a thickness sufficient to admit of their being reduced by means of suitable cutting machinery; or of being compressed at once, by hydrostatic or other mechanical pressure, into the exact segmental form required to constitute a portion of the nave—when bent and the ends brought

together—without the necessity of any subsequent operation of filing or otherwise fitting. A second portion of the invention consists in cutting or pressing the ends of the spokes into the requisite segmental form; and a third relates to the use of suitable cutting or pressing machinery for effecting this object. The bars may be formed in various ways, but the method which the patentees prefer, as being the readiest and most economical, is as follows:—A bar of iron is rolled of any convenient length—so as to form as many spokes in one bar as practicable—having suitable thickened parallel parts, or "swells," at proper intervals apart, according to the dimensions of the wheel to be formed. A bar thus rolled is represented at fig. 1, A being the bar, and B the thickened parts, or "swells." These said parallel swells, B, are then subjected to compression in moulds or dies, and they are thus reduced to the double wedge shape, as represented at C, in fig. 2. If the dies are accurately formed, a bar thus produced, when cut at the dotted line, C, and each piece bent into the proper triangular form, and the eight segments placed together, will form a wheel as shown at fig. 3, the joints at the nave requiring no further fitting previous to welding.

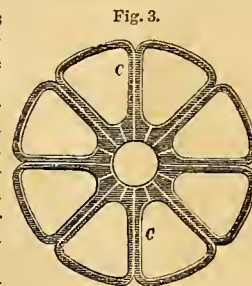

Fig. 3.

GAS HEATING AND COOKING APPARATUS.

W. F. RAE, Edinburgh.—Patent dated November 15, 1852.

According to one of the many modifications of gas-heated apparatus, detailed by Mr. Rae, the stove consists of a pair of vertical cylinders placed concentrically—one within the other, leaving an annular space between the two—the two cylinders being attached to a base, perforated to admit air. The top of the cylinders is covered over with a diaphragm of wire-gauze, or other porous or perforated material—over which diaphragm is either a single or double dome-shaped top, carrying a vessel for holding water, the dome being for the purpose of causing the heated air to issue laterally from the stove. The gas-burners may be placed either within the inner cylinder, or between the two, the burner being either a perforated tube, or an arrangement of fan, union jet, fish-tail, batswing burners, or burners of a similar class. When the burners are placed in the inner cylinder, the air to be warmed may be taken either from the apparatus containing the stove, or a communication may be opened up between the exterior cylinder and the outer atmosphere. If the burners are in the annular space between the two cylinders, the inner one may communicate with the open air, whilst the vitiated current is carried off by a passage from the external cylinder. Beneath the gas-burners a reflector is placed.



In applying the invention to heating water for baths or reservoirs, three cylinders are used, one within the other, the innermost cylinder having a series of short horizontal open-ended pipes passed through it. The water in the bath circulates through two pipes, one connected to the top, and the other to the bottom of the apparatus. The gas is consumed in a chamber beneath the cylinders, and the heated air passes

off up through the inner cylinder, and between the outer and the middle one. For cooking-stoves, the chambers are also constructed with an external air-space, that is, one rectangular chamber is placed inside another, slightly larger, the inner chamber being divided by shelves. The gas-burners are placed beneath the inner chamber, a curved or other overhanging cover being above them, whilst a space is left between the top of this cover and the bottom of the inner chamber, to allow the heated air to pass through and afterwards up between the two chambers, and off by a suitable discharge-pipe in the external chamber. A reflector is placed behind the burners, such reflector, as well as the lining of the inner chambers, being, by preference, of enamel. Above the chambers is a double top, divided into compartments, in which gas is burnt, for boiling and other cooking operations, and on the top a boiling and steaming apparatus may be placed, heated by a pipe or pipes from the stove beneath.

Our engraving represents an external elevation, partially sectioned, of a domestic or warming stove, complete. It consists of an open rectangular base, A, set upon ornamental feet riveted to it; and on this base is bolted down the moulding piece, B, carrying the external cylinder, or main shell, C, of the stove. To the base is also attached the cross-piece, D, from which spring brackets, E, to hold the internal cylinder, F; and on this cross-bar is also attached the concave reflector, G. The top of the internal cylinder terminates in an open cone, H; and beneath this cone, it has a series of holes, I, in it, to form a communication between the interior of the inner cylinder, and the annular space between the two cylinders. The outer cylinder is also open-topped, but it is covered in by a permeable diaphragm, and this again is covered by an ornamental cover-piece, L, secured by catches, so as to be removeable, and having an expanded open lower side. Over this cover is a hollow air-chamber, N, bolted down to the cover, L, and supporting the open vase, O, as the finish at the top. Access to the burners is obtained by a bottom side door, fitted with a talc window in the centre, a corresponding hole being cut in the inner cylinder to suit. The gas enters to the burners by the pipe, R, turning up by an elbow in the centre of the inner cylinder, to carry the three branches for the three burners, S. This compound gas-burner, when lighted up, heats the air in the inner cylinder, and from this the outer cylinder becomes heated, whilst air passes up from below, both through the inner cylinder and the annular space. The air thus heated passes of laterally from the top by the expanded cover, L, whence it is diffused over the apartment.

Amongst the other apparatus is a gas-cooking stove, in the form of a rectangular chamber, with an air-space all round, and fitted up with layers or stories of shelves, heated by a range of burners in the bottom of the structure, all the burners being protected from overhead drip by curved screens. A second pipe passes up to convey gas to burners on the top, for boiling and steaming. A third plan relates to a simple means of heating water for baths, whereby a few burners or jets keep up a constant hot-water circulation in the bath reservoir.

SHEATHING IRON SHIPS.

W. SEATON, *Albemarle Street, London.*—*Patent dated Oct. 1, 1852.*

Mr. Seaton's intention, in this contrivance, is to show how iron ships may be coppered with the same ease and facility as wooden ones. The object is twofold—the preservation of the iron from oxidation, and the prevention of fouling from the growth of sea-weed, barnacles, or animal-

Fig. 1.

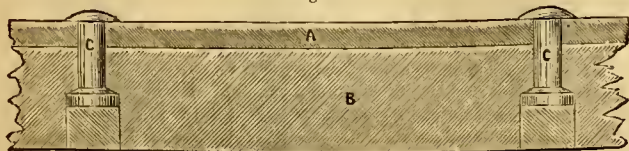

cule. To gain these points, the ship is planked with suitable timber, from the water-mark downwards, the planking being 2½ or 3 inches

Fig. 2.

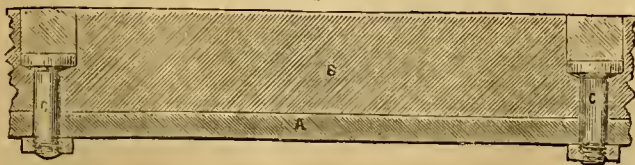

thick. The rivets or bolts for holding on this planking are countersunk externally, and the heads are covered up with wood plugs and marine

glue. Felt is also interposed between the wood and iron, to give a more secure combination. Fig. 1 is a section of part of a vessel so treated; A being the iron shell, and B the oak sheathing, beld on by countersunk rivets, C. Fig. 2 is a similar section, wherein the sheathing is bound down by bolts and nuts. This system affords an easy means of coppering the ship, in addition to its other important qualification of defence from direct mechanical injuries.

LUBRICATING SHAFT BEARINGS.

JOHN HICK, *Bolton-le-Moors.*—*Patent dated Jan. 12, 1853.*

This invention applies to the lubrication of all horizontal shafts and axles, and consists of the following simple contrivance:—At or near the centre of the brass, and at right angles, or nearly so, to the axis of the shaft, a groove or recess is formed, both in the upper and lower halves, so as to extend all round the journal of the shaft. The lower part of this recess forms a receptacle for containing oil, the upper level of which should at all times be below the lower surface of the revolving shaft to be lubricated. There is also a small horizontal groove or channel formed in the step, opposite to the centre line of the shaft, and parallel to it, extending to within a short distance of the back and front of the pedestal. The oil is placed in the lower part of the recess, and it is supplied to the journal of the revolving shaft by means of a metal ring, which is placed loosely thereon. The ring being somewhat larger in diameter than the shaft, the upper portion of the ring bears upon the shaft, whilst the lower portion dips into the oil in the recess; and as the ring revolves by frictional contact with the journal, it supplies the oil continually to the journal of the shaft, and the continued revolution of the shaft thus oiled necessarily supplies the lubricating liquid to the working surface of the step.

Fig. 1 of our engravings is a vertical section of a pedestal so arranged, and fig. 2 is a plan of the same detail, with the cap and upper brass removed. At A is the shaft to be lubricated, and B is the body of the pedestal; C is the cap of the pedestal; D, the lower brass or step; and E, the upper brass. It will be observed that each of these brasses is formed at its centre with a groove or recess, F; that in the lower step forming a vessel for the oil, and that in the upper one extending completely through the same, so that a fresh supply of oil may be introduced,

Fig. 1.

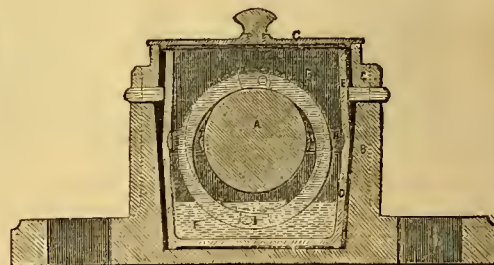
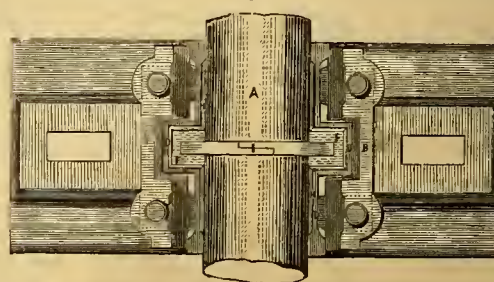

Fig. 2.



without removing the upper step, by merely raising the cap, C. There is also a small horizontal groove, H, formed half in the upper and half in the lower step, parallel to the centre line of the shaft, and extending to within a short distance of the back and front of the pedestal. I is the ring for supplying the oil to the shaft. This ring may either be solid or in two or more pieces, connected together as shown in the figures. As the shaft revolves, the ring revolves with it, and thus supplies the oil to the shaft, the continued revolution of which, aided by the groove, supplies the lubricating liquid to the working surface of the step.

PORTABLE FURNITURE.

A. D. BROWN, *Glasgow.*—*Patent dated Dec. 29, 1852.*

This is the practically good invention of an experienced cabinet-maker. It relates to the so constructing chairs, and other articles of furniture.

that they may be packed in separate pieces within a small compass, for easy storage and conveyance, whilst, at the same time, great strength is insured at the junctions, and peculiar facilities are afforded for taking down and rebuilding, or fitting up at pleasure. As applied to chairs, the plan consists in the adaptation of wedge or dove-tail joints, or modifications thereof, of metal, to the junction ends of the seat-frame and tops of the legs, the socket being on one piece, and the corresponding projection on the other; so that a firm joint connection is easily made, by slipping the corresponding surfaces into gear. The same arrangement is obviously suited for other articles of furniture, such as wash-stands, toilet-tables, stools, and other articles.

The chief illustration given by the patentee, is that of a drawing-room chair. In constructing chairs in this way, the tops of the front

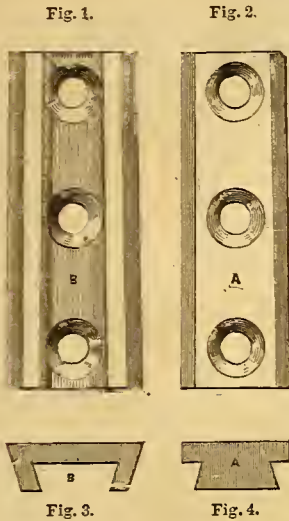

pieces from above. This binds the whole seat-frame well together, when wanted for use; but when wanted for conveyance, the parts are easily separated into six sections. In this way, if the arms are to be put on the same system is pursued, or, in consequence, two dove-tail ends, for the seat-frame joining the tops of tables each top of the latter dove-tail wedge-pieces, side of the table has two, so that the table, by sliding it on the feet or legs, the table is surrounded with projecting horizontal section, sunk pieces, F, on the of the legs.

legs and the back standards have each a projecting dove-tail wedge-piece, A, of brass, slightly sunk into the wood, and screwed down from the face. These dove-tail wedge-pieces are set with their narrow ends up, so that the two side pieces of the frame are capable of easy connection from the top side. Each end of the side pieces has a corresponding sunk dove-tail wedge-piece, B, dovetailed also externally, and sunk to its full depth in the wood, and secured by screws, like the others. These pieces, as shown in elevation and transverse section, in figs. 1, 2, 3, and 4, are put into their recesses in the wood from beneath; and as they do not reach quite through the frame-piece, no mark is left on the top of the frame. The dove-tail, or sectional wedge, thus prevents lateral separation, whilst the longitudinal wedge admits of tightening up by pressing, or gently striking the side

Fig. 5.

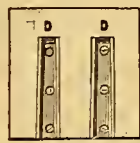

particular details, which with facility. When the chairs, precisely the each arm having, of connections, one at each end and back. In fastening to their pedestals, has one or more sunk dovetails, D, fig. 5, and the under corresponding projection can be easily attached laterally when inserted. And to attach base of the pedestal is in dovetail, E, as in fig. 6, corresponding to upper inner face ends

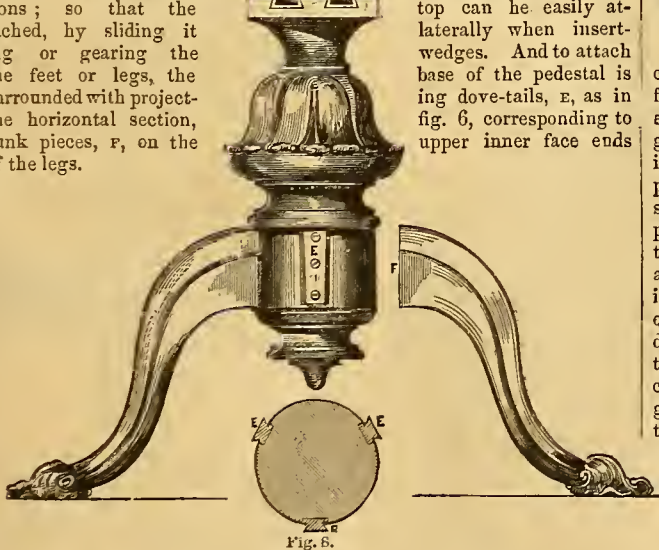

Fig. 6.

Mr. Brown exhibits several other modifications of his useful contrivance, pointing out that conical sockets and pins may be adopted instead

of the angular pieces which we have engraved. Furniture of all kinds, made on this principle, is now quickly coming into use; and, being peculiarly suited for export purposes, large quantities have found their way abroad.

TURNED WOODEN BOXES.

W. KENDALL, *Blawith, Lancashire*.—*Patent dated Jan. 24, 1853.*

This is a simple and economically rapid plan for hollowing or cutting out solid wood into boxes, or other receptacles of a like class. The apparatus consists, in general form, of a horizontal spindle, carrying a species of chuck, which is fitted with a projecting circular gauge, of the size of the outside of the box to be hollowed. In the centre of the chuck and gauge is a cutter made up of a small tool, fitted into a second revolving chuck, in such way as to permit a small portion only of the cutting edge to project. The wood blank, out of which the boxes are formed, is turned in a separate lathe, to the diameter required for the boxes, and is

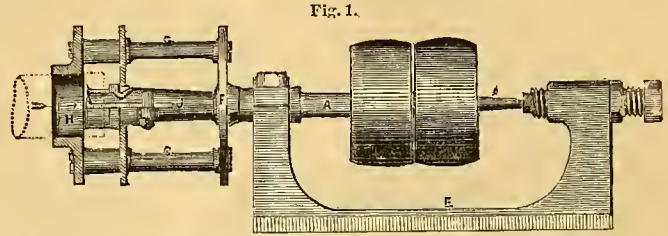

Fig. 1.

of any conveniently manageable length, so as to be capable of producing several boxes. This blank is placed with its axis coincident with the axis of the cutter spindle, and it is urged longitudinally forward by a runner, its end being inserted in the gauge, whilst the revolving cutter scoops out the wood. This forms the hollow of the box, and the piece so hollowed is then severed from the blank by a circular cross-cutting saw.

Fig. 1 is a side elevation of one form of this apparatus, and fig. 2 is an end elevation of the hollow gauge with the chuck and cutter in position.

The machine consists of the spindle or mandrel, A, driven by the fast and loose pulleys, B, and carried at one end in the journal bearing, C, of the front standard, and at the other, on an adjustable centre in the back standard, N. The two standards are cast in one piece with the base, E, like an ordinary lathe head-stock, the whole of the cutting details being

Fig. 2.

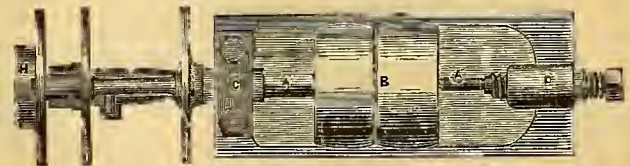

carried upon the front projecting end of the spindle overhanging the front standard, where a plain metal disc, F, is screwed upon the spindle end. From this disc, two parallel bars, G, project outwards, to carry the guide-disc socket, H, into which the blank, as dotted at I, is entered in turning. The mandrel, J, for carrying the cutter, is entered into the projecting end of the spindle, A; and as it overhangs its bearing very considerably, it is supported externally by the disc piece, K, carried by the pillars, L. The cutter, M, which may be of various forms to suit the particular work to be done, is fastened down to a hollow in the mandrel, by a screw clamp, N; with this arrangement, the blank, I, properly guided, is slowly traversed forward, as indicated by the arrow, in the direction of the axis of the mandrel; and this action is continued until the required depth of cut is obtained, as the cutter, M, works or cuts its way down into the centre of the end wood. The cutter and its position, as regards the centre of revolution, are so arranged as to cut the hollow to the required gauge of box, as must be obvious to the practical turner. The articles so turned or cut out, are then drawn off the blanks, and the operation goes on until the blank is expended. Various hollow articles may be thus made, the polishing and finishing thereof being separate final processes.

ADJUSTABLE DOG-CART.

JAMES BEGGIE, *Haddington*.—*Patent dated April, 18, 1853.*

This invention comprises—amongst several improvements in the details of construction of wheeled carriages in general—a simple, effi-

cient, and convenient contrivance for adjusting the bodies of vehicles of the "dog-cart" class back and forward, to suit the number of passengers carried.

Figs. 1 and 2 of our engravings are a side and end elevation of a dog-

cart constructed on this principle. It differs little in outward appearance from ordinary vehicles of this class. The body, *A*, is supported on a couple of iron cross-bars, *n*, which are fixed to the shafts, *c*. The body is capable of a back and forward traverse across the bars, *n*, and is

Fig. 1.

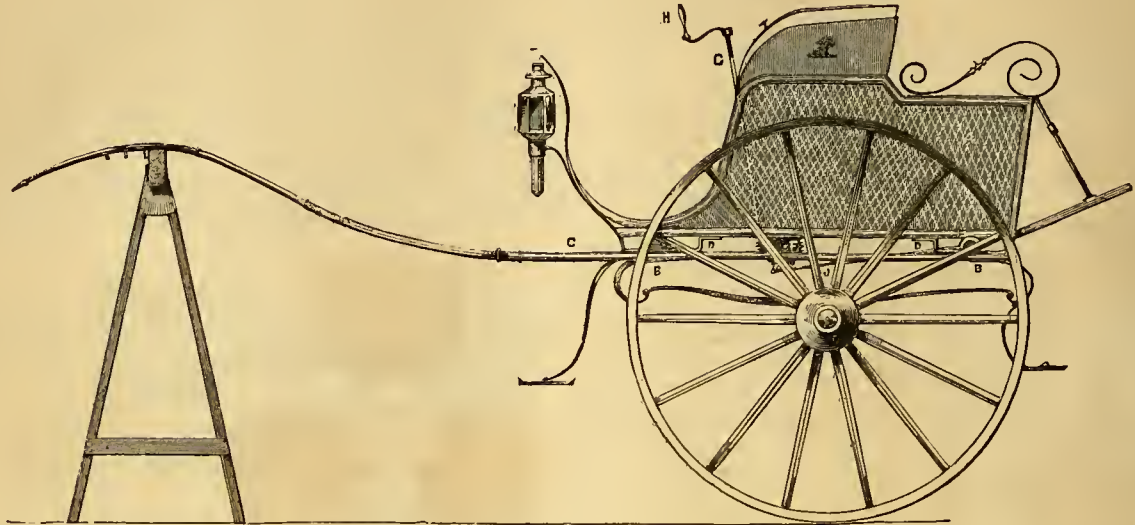

held down to them by iron straps, *d*, forming slots, in which the bars move, antifricition rollers being fitted to them at the points of support. The cross-bars, *n*, have also external collars, *e*, to prevent the body from moving on them sideways. The adjusting movement is obtained in the following manner:—Towards the front end of the under side of the body, and supported in suitable bearings fixed thereto, is a small worm-wheel, *f*, actuated by a worm, the spindle, *g*, of which passes up between the

Fig. 2.

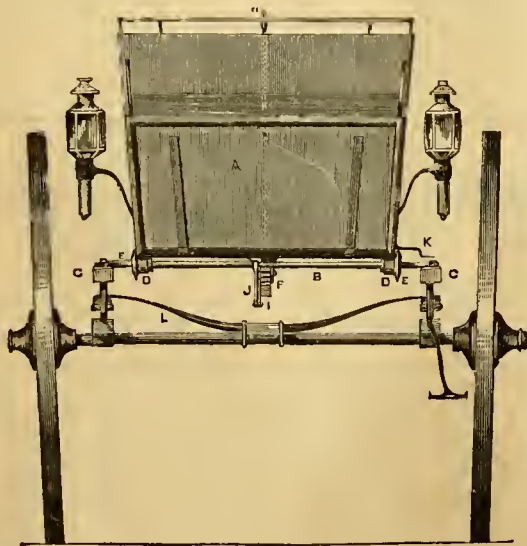

two front seats, where it is worked by a small crank-handle, *h*. To the worm-wheel, *f*, is fixed a crank, *i*, connected to the hindmost cross-bar, *n*, by a link, *j*. It follows from this arrangement, that, according as the handle, *h*, is turned in one direction or the other, a pushing or drawing action is exerted by the crank, and the body of the vehicle is pushed forward from, or drawn back up to, the cross-bar. An index-finger, *k*, is fixed to the carriage body at one side, and a corresponding scale is painted on the shaft, *c*, to show the proper adjustment for one, two, three, or four passengers.

A second of Mr. Begbie's improvements consists in the arrangements of the springs. According to the ordinary system, the springs of such vehicles are made of a strength calculated for the weight of four passen-

gers, and the consequence is, that when there are only one or two passengers they do not act, the light weight having no effect upon them, and the jolting is, in consequence, almost as severe as if there were no springs at all. To remedy this defect, Mr. Begbie applies a couple of springs in the usual way, but makes them much lighter, and adds a third spring, *z*, bolted by its centre to the axle, and lying across the vehicle. The ends of this spring are not attached to the shafts, but are free, and, when the vehicle is empty, are about three inches below the shafts. Vulcanized india-rubber cushions are fixed to the shafts where the ends of the additional springs strike, to soften concussion and avoid noise. It is obvious that, when there are but one or two passengers, the body of the carriage will be borne up by the light springs, which will be fully efficient in this state of matters; but when the load is increased, the additional spring has to assist in sustaining it, since the body will necessarily sink down until in contact with it.

Mr. Begbie also forms the spokes of the wheels of uniform section throughout. The form of section he prefers is the lozenge, and he fits the spokes into a cast-iron nave without shoulders, giving them almost their entire sectional size as far in as they reach. Fig. 3 is an elevation, and fig. 4 a section of the nave, showing the form of spoke and the manner of fitting it into its socket. The form of the spoke obviously affords great facilities in construction, whilst it involves a much less waste of material, still presenting an appearance quite equal to the form ordinarily used. In fig. 4 is also shown the method of securing the nave upon the end of the axle. A nut, *m*, with a beveled collar, is screwed on the end of the axle, the collar retaining the wheel in its place, whilst the end of the nave is covered in by a neat screw-cap, *n*. Hollow spaces, *o*, *p*, are cast in the nave to retain lubricating matter.

Carriages of this kind have long been favourably regarded for their lightness and general convenience, and Mr. Begbie's improvements must undoubtedly add considerably to their other advantages.

Fig. 3.



Fig. 4.

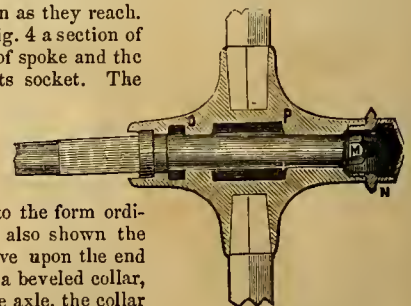

METALLIC TUBES.

T. POTTS and J. S. COCKINGS, Birmingham.—Patent dated Jan. 17, 1853.

This curious contrivance relates—under its first head—to a mode of making locomotive engine boiler tubes, wherein the power necessary for the reduction of the thickness of the metal, and the lengthening of the tube, is applied in a direct manner, whilst the mandrel, used for supporting the external pressure, may be easily withdrawn. Fig. 1 is an end elevation of a

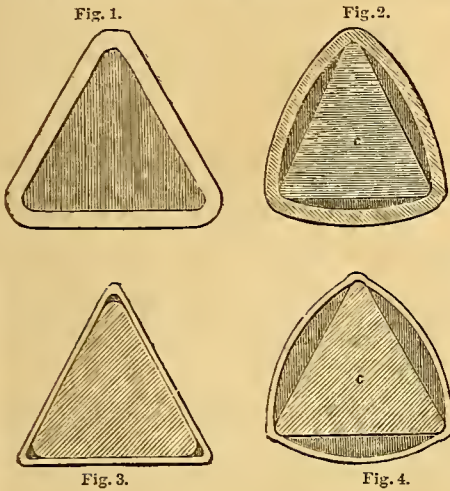

described under the second head of the invention.

In using this apparatus, the rollers, figs. 5 and 6, being set for the first operation, the heated billet is put on a mandrel, and passed through the rolls, *b, b*. It is then passed through the rolls, fig. 7, still being in the heated state, and it then assumes the sectional form of fig. 2. This latter operation has the effect rather of increasing the circumferential dimension than the length of the embryo tube, and the mandrel, *c*, may thus be removed with very great facility. The next operation, as illustrated in figs. 3 and 4, is similar to that just described; and the process is carried on in these stages until the metal is reduced to the necessary tenuity, and the tube brought to the length intended. The top rolls are screwed down closer at each operation, and the metal is heated as will be required. The final operation is the reduction of the section, fig. 4,

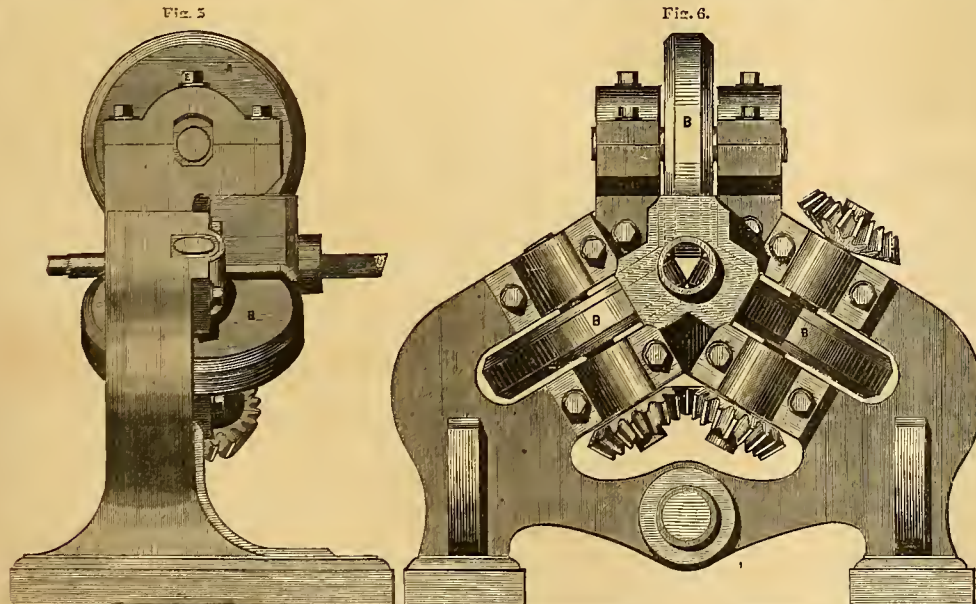

to that of the required cylindrical tube, and this is done at a common draw bench, with the metal in a cool state.

The modification introduced in the manufacture of calico-printing

rollers refers to the production of the inside projecting piece, which, in the old process, has always been a very tedious point. By the new plan, a flat piece of copper of the required length, width, and thickness, is taken as the raw material of the roller, and its opposite parallel edges are planed to the contour, *a*, fig. 8. This flat piece of metal is then brought to the tubular form, first by a hammer and swages, and then by drawing or rolling, until the two edges come together, so as to hold the inserted piece of metal, *b*, which is separately drawn to correspond to the indented edges, *a*. The piece, *b*, is further secured in position by soldering, and as it is desirable to get the junctions as smooth as possible, the roller is subsequently drawn through a collar, to close it well. The third head relates to the application of tubular copper wire for telegraphic communication, tubing being also used for joining such wires together. In effecting such junctions, the patentees take a short piece of tube, ten inches in length, for example, the interior of such tube being fitted to the exterior of the long lengths. Then the two ends of

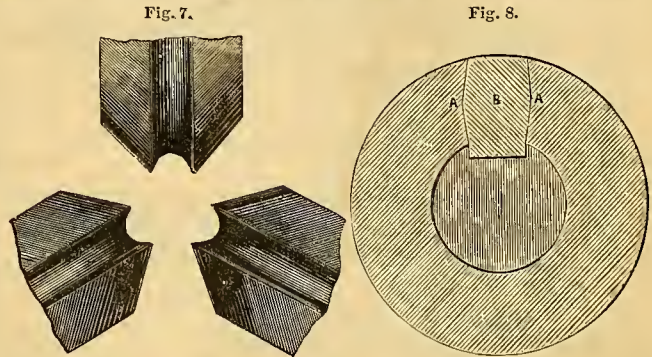

the main tube being laid together, the outer piece is put over them at the joint, and, with a pair of pliers, the wire and junction-tube are squeezed together, a neck being formed in one or two places by turning the parts during the nipping operation. In this way, by the substitution of hollows for solid wire, a great saving is effected in the amount of raw material used for telegraphic connections.

REGISTERED DESIGN.

COMPOUND CARRIAGE SPRING.

Registered for Mr. J. J. CAFFERTSON, C.E., London.

This spring is very beautifully contrived for securing great elasticity and ease of movement. Fig. 1 is a side view of the spring, and fig. 2 a plan corresponding. The bar, *a*, is the fixture, forming the means of communication from the carriage frame through the spring to the axle. The compound spring itself consists of four separate springs, *b, c*, and *d*. The two springs, *b*, are fixed to the bar, *a*, at such a distance apart as to admit of the spring, *c*, playing between them. The spring, *c*, is fixed to the bar, *a*, and is connected to the spring, *d*, by a shackle, *e*. The springs, *b*, are also connected by another shackle, *f*, to the spring, *d*, which is attached to the axle, *g*, of the carriage. The springs, *b*, are fixed between two plates, which are united by four bolts and nuts. The whole is fixed to the bar, *a*, by two bolts and nuts. The lower plate is notched out to receive the end of the spring, *c*, when the spring is depressed to its greatest extent, and a block of wood is placed between the springs, *b*, and serves as a packing to keep them in their proper positions. The spring, *c*, is fitted tightly into a clip with a packing piece of wood, and the clip is secured to the bar, *a*, by a screw forged with it, and provided with a nut. A small recess is made

in the bottom of the bar, A, so that, by screwing up the nut, the spring is firmly pressed up to the bar. The spring, c, is further secured by another bolt and nut passing through it, and passing through the plate and bar.

In comparing the "compound" spring with the common springs, the relations stand thus:—

In the ordinary elliptic spring—taking each length to be one foot—we have four lengths of one foot each, or four feet of spring. In "three-fourth elliptic and cross" springs, there is also an aggregate of four feet; and in "telegraph" springs we have still the same; whereas, in the compound spring, there are two lengths of one foot each = two feet and two lengths of two feet each = four feet, or six feet in all—showing 50 per cent. of spring, in favour of Mr. Catterson's invention. And this is

Fig. 1.

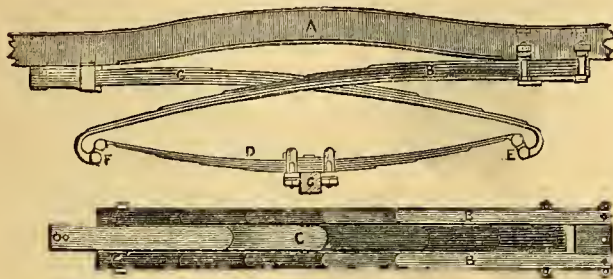

Fig. 2.

gained, not by increasing the number of lengths, but by doubling the length of two, so as to secure superior ease. The ease, indeed, is equal to that of a c-spring. The cost of the new spring is less; and no perch-pole is required, so that carriages may be built as low as the necessary clearance of the road will allow; and there being no perch-pole, the front wheels lock completely round. A complete model of the spring is at the Polytechnic Institution.

REVIEWS OF NEW BOOKS.

SUMMARY OF THE LAW OF PATENTS. By Charles Wordsworth, Esq., Barrister-at-Law. London: Benning & Co. Pp. 140.

When a man opens up a new path in technical literature, those who are interested in the subject are generally too well pleased to find it adopted as a theme for dissertation, to judge severely of the mode of its treatment. All after-comers, however, in the same department, are expected to contribute some special service—deeper investigation into the theory and principles of the matter, or more complete practical detail, or a more convenient arrangement and clearer exposition of matter already acquired. All this has been done for patent law. The general principles have been canvassed, as may be seen in the blue books and parliamentary reports,—the practice has been explained by men of ability and experience, and popular manuals, more or less meritorious, have repeatedly appeared. But in neither point of view can the present work be admitted to commendation; the general rules and maxims are inaccurate, or so defective as to be equally misleading;—thus the duty of the specification is defined to be the instruction of the public after the expiry of the term, the more immediate function of defining the frontier lines of the patentee's privileges being omitted. The idea that Watt retained a monopoly of steam-engine building for thirty years after his patent, because he worded his specification unintelligibly, is amusing. It is as if a man professed ignorance of the form of a hippopotamus, because he had never read Buffon, while he might see the reality at the Zoological Gardens. And the misapprehension is the less tolerable, as involving a revival of the reproaches and opposition to the great mechanician, which well nigh repaid the benefits conferred on his country, with ruin to himself. His compeer in the ranks of utility, Arkwright, perhaps deserved his persecutions; but his case is not well employed in the present work to show that surplusage in a description vitiates—a doctrine very ungermane to English jurisprudence; a material qualification is omitted, surplusage thrown in to mislead is fraud, and fraud does vitiate. The author might with advantage have perused Mr. Sweet's caution to persons meddling in patent matters with regard to the word *principle*; he lays down that the subject of the grant may be a principle, or a machine embodying a principle: from the collocation of the two things, we presume that the former

means a principle not embodied, a doctrine that will not stand in court or in the agent's office either; and, as to the latter, the author imagines that some machines embody no principle or law of nature, but act fortuitously, or because they cannot help it.

Much of the text consists of brief rules, as undeniable as proverbs in conversation, but equally indefinite in application, and equally useless. Thus, in speaking of the claim for an extension of term, want of *adequate* remuneration is very truly introduced; in fact it is rather the qualification, than one among them, but no aid is afforded in forming an estimate of its amount. The inventor, indeed, can easily satisfy himself of the insufficiency of his reward; the question is, whether the Privy Council participate in his impression. So in reference to the test of inventorship, it is laid down that your idea is not to be taken from a book, or suggested by another person; but, it is added, that the point turns on niceties, readily appreciated by practitioners, but not easily expressed in a few words.

The statement regarding the nature of an infringement, page 39, implies that the courts of law and equity differ as to whether unconsciousness of trespassing excuses the infringement in point of fact; but general principle should have suggested that you can hardly be allowed to use another man's property on the ground of *mistaking* it for your own; and an examination of the more recent trial of the same case would have cleared up the apparent anomaly, which arose from confusing the defendant's consciousness of moral dishonesty with his knowledge from ordinary sources as one of the public, that carbon and manganese are a notorious equivalent for carburet of manganese. If his experiment first proved this, he was a legitimate inventor.

With reference to practical forms, the petition for a prolongation (in which all mention of the substantial merits is omitted) is of more remote interest to the inventor, than the process of a disclaimer, of which no notice is taken; and though the forms of pleadings given are delightfully simple, it is to be feared that no authoritative restrictions will long withhold that class of documents from running to seed. At another part, Beard's title is quoted at full length; but though ultimately sustained, it is a peculiarly bad model for imitation, and the moral deducible from it, is the huge trouble and expense to which an ill-selected title may sometimes lead.

The work appears compact, but it is not compendious; this quality can only exist with wider acquaintance with a subject. Thus the question, much debated at one time, about an exclusive license (*Rotheroe v. May*), derived its interest from the now omitted proviso respecting patent partnerships, which that kind of license successfully evaded. The larger portion of the volume consists of official rules, and acts of parliament, a compact copy of which may sometimes be useful, but the modern practice of converting such an assemblage of statutes, by the appendage of a few crude remarks, into the form of an original treatise, however frequent, is always to be reprobated.

CORRESPONDENCE.

THE PARALLELOGRAM OF FORCES.

The geometrical demonstration of the composition and resolution of forces, by means of the parallelogram, or, more correctly, by the triangle, is well known; but much difficulty has been met with in applying it to some particular cases—the action of oblique forces, for example. Thus, in "Warr's Dynamics" will be found an intended demonstration of loss of power from oblique action, in certain positions of the connecting-rod of a steam-engine, the same reasoning, of course, applying to the loss of power in the crank, about which there has been so much discussion from time to time. Again, in some recently published investigations on the action of the screw propeller, it is stated that the pressure of the blade upon the water may be resolved in two directions—one parallel, and the other perpendicular to the shaft. The former of these alone, it is added, is efficient in overcoming the resistance to the vessel's motion, the latter being, therefore, it is to be supposed, lost. If this is the fact, the paddle-wheel need not sink into oblivion just yet, for there is, at any rate, no such loss of power with it.

I would suggest that the cause of these fallacious deductions consists in considering the acting power as a magnitude of *one* dimension. Now, motive power never can be such; it is, in fact, a magnitude of *three* dimensions; but when time is taken as unity, it may be treated geometrically as one of *two*. We ought therefore to employ surfaces, and not mere lines.

To make my meaning more intelligible, I will treat the case of the screw propeller according to the proposed method.

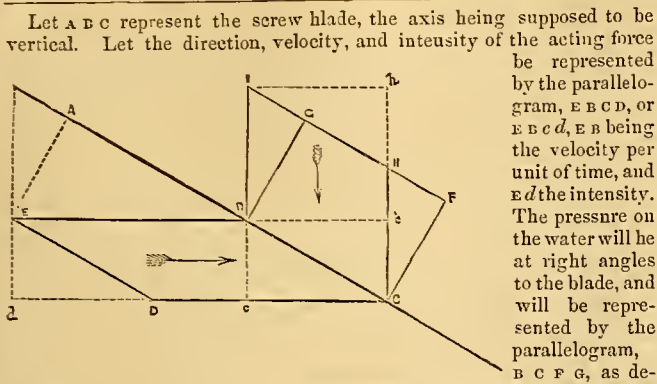

Let $A B C$ represent the screw blade, the axis being supposed to be vertical. Let the direction, velocity, and intensity of the acting force be represented by the parallelogram, $E B C D$, or $E B C D$, $E B$ being the velocity per unit of time, and $E D$ the intensity. The pressure on the water will be at right angles to the blade, and will be represented by the parallelogram, $B C F G$, as determined by a very obvious construction. Again, the resistance to the same elementary portion of the blade will be represented by the parallelogram, $B C' H I$, or $B C H I$, $B I$ being the corresponding velocity, as determined on the principle of the inclined plane; or by the triangle usually applied to the resolution of forces, and $B C'$ the consequent intensity.

From the parallelogram, $B C H I$, by a construction similar to the previous one, we obtain the parallelogram representing the action of this resistance at right angles to the blade, and it will be found to coincide with the parallelogram, $B C F G$, representing the pressure of the blade upon the water. due to the acting force represented by the parallelogram, $B C D E$. Now, the parallelogram, $B C' H I$, is obviously equal to $B C D E$ —thus showing that the resistance accounts for *all* the acting force.

The case of the crank, or oblique connecting-rod, may be treated in the same manner. In the more complicated case of the screw, both power and resistance acting obliquely, the intermediate parallelogram, $B C F G$, is required; but in the other cases it is not.

I would remark that this diagram proves nothing; but neither does the diagram hitherto employed.

Such diagrams, as well as all algebraical formulæ, are but methods of representing what we suppose to be facts, in a manner and form enabling us to arrive at a better estimation of them—they but describe in a more precise and comprehensible language.

The method here proposed may be appropriately termed as "of the parallelogram of forces;" whilst the old method should simply be called that "of the triangle of velocities or pressures."

GOOSEQUILL.

Glasgow, July, 1853.

STOPPING AND BACKING STEAMERS UNDER WAY.

Having been lately placed in certain peculiar circumstances on board a steamer, I am anxious to learn your opinion on the following point in reference thereto:—A steam-ship is running with fore and main square sails set, with a light wind and sea, at eleven miles an hour, her dimensions being thus—tonnage, 1,945; length, 225 feet; beam, 35 feet; draught of water aft, 16 feet 10 inches; forward draught, 16 feet; diameter of paddle-wheels over tip of floats, 27 feet; number of floats, 17; surface of each float, 36 feet; diameter of cylinders, 75 inches; length of stroke, 7 feet; steam pressure, 12 lbs.; the engines, direct-action ones, in good working condition. Under these circumstances, in what time could the vessel be brought to a stand? and when could the engines be started to go astern, supposing the order to be given to stop and go astern in the shortest possible time, all sail being taken in at the time?

August, 1853.

W. S. S.

PROCEEDINGS OF SCIENTIFIC SOCIETIES.

ROYAL SCOTTISH SOCIETY OF ARTS.

This Society held an extraordinary meeting in their Hall in George Street, Edinburgh, on Monday, 11th July, 1853—Daniel Wilson, LL.D., Vice-President, in the chair.

The following communications were made:—

Dr. Lees read a Review of the different Theories of the cause of the Antilunar Tide held by different Philosophers. By John Campbell, Esq., F.R.S.E.

Communication of a method of Preserving Butter, Cheese, Ham, &c., in a fresh state during a Voyage, when exported to warm Climates, as practised in Holland, but not generally known. By Mr. Malcolm McCallum, Cannon Street, Leith.

Description and Drawing of the Torricellium, a proposed self-acting Instrument for effecting a more perfect Vacuum than the Air-Pump. By Mr. P. Macfarlane, Comrie.

No. 68.—Vol. VI.

SOCIETY OF ARTS.

99TH SESSION.—JUNE 10, 1853.

DISTRIBUTION OF PRIZES.

The prizes for the session were formally distributed on this day, in the presence of a crowded assemblage of interesting visitors. The following is the list:—

THE ISIS GOLD MEDAL.

Mr. William Clerichew, of Ceylon, for his improvements in the Curing of Coffee.

THE ISIS MEDAL.

Mr. James Taylor, of Elgin, for his Essay on the Cotton Manufactures of India. Admiral Sir Henry Hart, of Greenwich, for his mode of Curing Smoky Chimneys.

Mr. J. Rock, jun., of Hastings, for his new Carriage Spring.

THE SILVER MEDAL.

Mr. Joshua Rogers, of 133 Bunhill-row, for his Shilling Box of Water Colonns. Mr. John Cronmire, 10 Cottage-lane, Commercial-road East, for his Half-crown Box of Mathematical Instruments.

Mr. Henry Weekes, A.R.A., for his Essay on the Fine Arts department of the Great Exhibition.

Mr. F. C. Bakewell, for his Essay on the Machinery of the Great Exhibition.

Mr. R. G. Salter, for his Method of Flushing Sewers.

Mr. V. Vaughan, of Maidstone, for his Machine for putting up Chimney-pieces.

THE SOCIETY'S MEDAL.

Mr. W. Bollaert, for his Essay on the use and preparation of Salt.

Mr. H. Owen Husskison, for his Essay on the use and preparation of Salt.

Mr. John Dalton, of Hollingworth, for his Double Register Calico-Printing.

Mr. G. Scholes, of Landport, for his Slide Motion Indicator.

Mr. G. Edwards, for his Improved Portable Photographic Camera.

Mr. J. Toynbee, F.R.S., for his Artificial Tyrampic Membrane.

Mr. W. Wood, for his improved method of Teaching Music to the Blind.

Mr. A. Claudet, for his Essay on the Stereoscope, and its application to Photography.

Mr. Joseph Hopkins, of Worcester, for his mode of giving Equatorial Motion to Telescopes.

Mr. G. Jennings, for his improvements connected with the Drainage of Houses.

Mr. H. J. Saxby, of Miletown, Sheerness, for his new Lock. (And £10.)

Mrs. A. Thomson, of New Bond-street, for Four Drawings in Outline.

Mr. W. Stones, of Queenhithe, for his Essay on the Manufacture of Paper.

M. C. Shepherd, jun., of Leadenhall-street, for his improvements in Electric Clocks.

The Rev. W. T. Kingsley, of Cambridge, for his discoveries in Photography.

The Very Rev. the Dean of Hereford, for his Essay on Self-supporting Schools.

Mr. James Hole, of Leeds, for his Essay on the History and Management of Literary, Scientific, and Mechanics' Institutions. (And £50.)

THE THANKS OF THE SOCIETY.

Dr. Robinson, of Newcastle, for his Improved Safety-Lamp for Miners.

Mr. Jonas Bateman, for his Improved Life-Boat.

Dr. Stolle, of Berlin, for his Essay on the Manufacture of Sugar.

Dr. Cumin, of Bath, for his Specimens of Paper from Sugar-cane Refuse.

Dr. Lloyd, of Warwick, for his Samples of Paper made from the Refuse of Cow-houses.

Professor Jack, of New Brunswick, for his Essay on the Decimal System of Weights and Measures.

INSTITUTION OF CIVIL ENGINEERS.

SESSION 1853-4.

SUBJECTS FOR PREMIUMS.

The list of subjects on which the Council invite communications for premiums, for the ensuing session, comprehends the following new heads. The numbers attached to each represent their position in the list:—

7. The history and practical results of Timber and Iron Piling for Foundations, with notices of mechanical modes of driving.

11. The forms and dimensions of Journals of Machine Shafts, Axles, &c., with the best Composition for the linings of bearings, and the most approved methods of lubricating.

23. Improvements in the Manufacture of Iron for Rails and Wheel Tyres, having special reference to the increased capability of resisting lamination and abrasion.

24. On the Cost of Maintenance of the Permanent Way; noticing the principal systems in use for the last ten years, and the depreciation of the Rolling Stock of Railways.

27. On the Construction of Catch-water Reservoirs in Mountain Districts, for the supply of Towns, or for manufacturing purposes.

Nos. 15, 24, 27, and 39 of last year's list, as printed at page 240 of our Volume V., are expunged. These alterations make up the list for the year.

The communications must be forwarded, on or before the 30th of January, 1854, to the house of the Institution, No. 25 Great George Street, Westminster, where any further information may be obtained.

T

MONTHLY NOTES.

PROGRESS OF SCREW-PROPULSION.—MARINE MEMORANDA.—The Eastern Steam Navigation Company has now published its proposed arrangements in full detail. The first ship, to be ready in eighteen months, has been contracted for with Messrs. James Watt & Co., and Messrs. Scott Russell & Co., the hull to be built on the Thames by the latter firm, and the engines at Soho. The dimensions and power of the ships are intended to be as follows, viz.:—length, 680 feet; breadth, 83 feet; depth, 58 feet, with screw and paddle engines, aggregate nominal horses-power, 2,600. The conditions, indispensable to expeditious and regular steam voyages from England to Australia or India, and which the ships must be calculated to fulfill, are—1. That they shall not be obliged to stop at any place by the way to take in coal, stoppages for coal not only causing great delay by the time required for coaling, but compelling the vessels to deviate widely from the best route, in order to touch at the necessary coaling stations. 2. In avoiding the delay of coaling on the voyage, the ships will also escape the great cost of taking coals at a foreign station. Coals, on the Indian and Australian route, cost on the average, including waste and deterioration, four or five times as much per ton as in this country. The present ships will take their whole amount of coals for the voyage from near the pit's mouth, at a rate not exceeding, for the best quality, 12s. to 14s. per ton. On the voyage of existing steamships to Australia or India and home, the consumption amounts to from 4,000 to 6,000 tons; the cost of which would supply 15,000 to 20,000 tons, if taken on board at some port in immediate communication with the coal-field. But these ships will carry, besides their own coals, upwards of 5,000 tons measurement of merchandise, and will have 500 cabins for passengers of the highest class, with ample space for troops and lower-class passengers. These the Company will not only be able to carry at rates much smaller than those by any existing steamships, but with an unprecedented amount of room, comfort, and convenience, which the great size of the vessels will afford. In thus increasing the size of the ships, the directors believe they are also obtaining the elements of a speed heretofore unknown; and if hereafter coals applicable to the purposes of steam can be supplied from the mines of Australia, their carrying capacity, both for cargo and passengers, will be proportionately increased. The great length of these ships will, undoubtedly, according to all present experience, enable them to pass through the water at a velocity of 15 knots an hour, with a smaller power, in proportion to their tonnage, than ordinary vessels now require to make 10 knots. It is thought that, by this great speed, combined with the absence of stoppages, the voyage between England and India, by the Cape, will be reduced to from 50 to 33 days, and between England and Australia to 33 to 36 days. The hulls of the ships will be of iron, and of more than usual strength. The whole of their bottoms, and up to six feet above the water-line, will be double, and of a cellular construction, so that any external injury will not affect their tightness or safety. The upper deck will also be strengthened on the same principle, so that each ship will be a complete beam—similar to the tube of the Britannia Bridge. The vessels will be divided into ten completely separate water-tight compartments, and, as the intermediate spaces are sufficient in such ships, being each 60 feet in length, to afford a convenient arrangement of separate saloons and cabins, the bulkheads can be carried completely to the upper deck, giving an efficiency to the system of compartments which has not yet been attainable. Separate sets of engines, each with several cylinders and separate boilers, will be applied to work the screw, distinct from those working the paddle-wheels, so that, in the event of temporary or even permanent derangement of any one of the engines, or of either the paddle-wheels or of the screw, the other engines and propellers would still be available, and the only result would be a proportionate diminution of speed and consumption of fuel, thus rendering the chances of any serious delay almost infinitely remote.

The *Great Britain*, fitted with Griffiths' screw, has given 12½ revolutions with 18 revolutions of her engines—Captain Claxton remarking, "If circumstances had permitted of her being run to leeward, I have no kind of doubt whatever that she would have gone over fourteen knots, or sixteen miles and a third. With the same screw, fixed perpendicularly, and the ship close hauled, she went ten knots, to my very great astonishment, and that, I believe, of every nautical man on board; while, with the screw disconnected and revolving, her speed was not quite so great, thereby, apparently, showing that Griffiths' screw need never be disconnected, a matter of first-rate importance to auxiliary steam navigation."

The *Rajah*, screw steam-collier, belonging to the Peninsular and Oriental Company, has also been fitted with Griffiths' screw, and her trial-tests give an increase of speed of a quarter of a knot, with six revolutions less of the engines.

In the subsequent trials of the Boomerang screw in the *Conflict*, the average of six of her runs was 9.378 knots, with 65½ revolutions of the engines. This result being equal to about two-thirds of a knot over the performance of the *Conflict's* own propeller, Sir Thomas Mitchell, the inventor, is said to have challenged Griffiths' to do as much with the same vessel. The propeller used in the *Conflict* was made by Messrs. Taylor & Co., of Birkenhead, and is an excellent piece of work.

Late trials with the *Miranda*, screw steam-sloop, showed a rate of 10.75 knots, the maximum rate of her engines being 29. The water was very smooth at the time, and the wind in force about 5. The screw was propelled about three times the velocity of the engines by gearing, which worked remarkably well. Her draught of water was—forward, 12 feet 3 inches, and aft, 12 feet 6 inches. The upper blade of the screw was about one foot above the water. The rate of 10.75 knots is considered a remarkably high speed for an auxiliary power at such light immersion. It is, therefore, confidently expected, that her speed will not be materially diminished when at deep immersion, after she has received all her stores and armament.

A new screw, which, for want of a better distinguishing name, has been called the "spiral propeller"—the invention of Mr. Scott, of the Tranmere Foundry, Liverpool—has been tried in the steamer *Weaver*, borrowed from the trustees of the Duke of Bridgewater for the purpose. She was pitted against the *Countess of Ellesmere*, and during two trips between Liverpool and Runcorn, the *Weaver* was beaten by 12 minutes. But the *Weaver's* economy of fuel was shown to be 16 per cent. superior. The spiral propeller is formed on the principle of obtaining as much propelling surface on the outer edge of the blade as possible, at the same time allowing the greatest liberty near the centre, so as to offer the least resistance in the passage of the screw through the water. The propeller has two blades, something resembling the blades of the old-fashioned screw, with a piece cut out of each, thus giving them the shape of an elbow, being diametrically opposed to Griffiths', where the outer edge has the least surface.

In paddle-ships, great interest is just now excited by the *Vectis* and the *Valetta*, of the Peninsular and Oriental Company. These vessels, supposed to be by far the fastest steamers of their class in the world, have been built on the new diagonal principle, by two rival shipwrights, the *Valetta* by Marc of Blackwall (designed by Mr. Waterman, jun.), the *Vectis*, by White of Cowes. They are of precisely the same size and tonnage, and are both supplied with machinery of equal power, each being fitted with Penn's oscillating engines of 400 horses-power, Lamb and Sumner's flue boilers, and feathering paddle-wheels. Such being the case, and the only difference in the vessels being those introduced by the respective builders in reference to the shape and form of the vessels under the water-line, the task of deciding which builder has produced the form best calculated for speed, with the same propelling power, has been an interesting and curious one. Both ships are 950 tons, and 400 horses-power, and both are built on the recently patented principle of Messrs. White, noticed by us a short time back.* When first tried, the *Valetta* crossed between Southampton and Cherbourg in 4½ hours; but afterwards, at the measured mile in Stoke's Bay, the following was the return:—

1st run in	3 minutes 44 seconds,	equal to	16.071 knots.
2nd "	4 " 20 "	" "	13.846 "

Giving an average of 14.958, say nearly 15 knots, equal to over 17 miles an hour. Subsequently, four runs were made with the *Vectis*, as follows:—

	min. sec.	Average.
1st run in	3 40,	equal to 16.363 knots.
2nd "	4 26,	" 13.533 "
3rd "	3 47,	" 15.895 "
4th "	4 10,	" 14.400 "
		14.948 knots.
		15.129 "

The average of the four runs being 15.038 knots, equal to 17.414 statute miles per hour. A small alteration was then made in the trim of the vessel, with the object of floating her a little more by the head, and two additional runs, under these circumstances, exhibited as follows:—

	min. sec.	Average.
5th run in	3 55,	equal to 15.319 knots.
6th "	3 57,	" 15.190 "
		15.254 knots.

Contrasted with the speed of the *Valetta*, the result is in every way favourable to the *Vectis*, showing a difference on the mean of the four runs, in favour of that ship, of 0.080 knots, and of the six runs, of 0.122 knots per hour; while, if the two most favourable runs of the *Vectis* be placed against the two quickest runs of her consort, the difference in the favour of the former vessel would be 0.296, or nearly one-third of a statute mile an hour. The palm of success must therefore, unquestionably, be given to the Cowes ship. At the same time, it should be stated, that the *Valetta* on her trial made, on the average, about three-quarters of a revolution less per minute than the engines of the *Vectis*. It is expected that the two vessels will make the run between Malta and Marseilles in about 50 hours. The *Valetta* has, indeed, made the run in 47 hours, the shortest time in which any vessel ever ran 660 miles under steam. The well-known *Banshee* never did it in less than 51½ hours. Reduced to statute miles per hour, the *Valetta's* performance is 16.36 miles—for, let it be remembered, continuous work.

The African Mail Steam Company has adopted Welsh anthracite coal in the packet-ship *Faith*. As the ordinary draught is quite unequal to the task of burning this fuel, a large steam-pipe is connected with the boiler steam-chest, and brought down in front of the furnaces, so that the engineer can admit a powerful steam-jet to his burning fuel. With coal of this class, the steam-jet produces a very intense heat, with great rapidity. The proprietors expect to effect considerable economy by the use of this fuel.

LOCOMOTIVE EXPENSES ON THE EASTERN COUNTIES RAILWAY.—The number of miles run by the trains on this line, during the last half-year, was 1,625,274; the cost of working, £67,309; and the miles of railway worked, 434½. And in the corresponding period of 1850, 1,185,628 miles were run; the cost of working, £85,070; and the length of railway worked, 327¾ miles. Showing an increase in the length of railway worked, of 106½ miles; in the number of miles run, of 439,646 miles; and a decrease in the working expenses, of £17,761. The average cost of working, in the half-year ending the 4th of July, 1850, was 17.22d. per mile per train, including 13.89d. for locomotive power; and in the half-year ending the 4th of July last, the cost of working was 9.94d. per mile per train, including 7.88d. for locomotive power. Comparing the cost of working per mile per train in 1850, with that of 1853, a saving of £49,306 is shown on the half-year ending the 4th of July last. The increase in the number of miles run by the trains over that of the half-year ending the 4th of July, 1852, was 152,164 miles, attended by an actual decrease of expenditure of £894.

* See page 179, Vol. IV., *Practical Mechanic's Journal*.

THE NEW YORK EXHIBITION—THE EXHIBITION AT MOSCOW.—Our last reports from New York inform us that, although opened, the American Exhibition is still in an incomplete state. The articles are divided into 31 classes, very slightly modified from the arrangement laid down by us in 1851. One of the most important of the contributions is a new printing press, which prints from uncut paper, rolling from a cylinder, and cuts and folds, with perfect regularity, 30,000 copies per hour. There is no confection in the process, and consequently no time lost in returning motion. Both sides are printed at the same time, and 30,000 per hour is a low estimate, since, by increasing the speed, they can be printed as fast as paper or cloth can be unrolled from a cylinder. The inventor declares that he can print a mile of newspaper as fast as a locomotive can traverse a railway.—There is also a thrashing machine, which, with four horse power, thrashes, cleanses from smut, winnows, measures, and bags, from 1,000 to 2,000 bushels of grain per day.—Complaints are made that the directors have allotted very large spaces, in some of the most prominent localities in the building, for the display of articles of the most trivial description.—The Moscow Exhibition has just closed, with what has there been deemed success. What that success amounts to is measurable by the fact, that there were in all 568 exhibitors, whose contributions were viewed by a total of 35,000 visitors.

CAPTAIN NORTON'S RECENT EXPERIMENTS WITH PROJECTILES.—After the late regatta at Cork, Captain Norton exhibited two of his projectiles in a boat in the deep part of the river, one being his submarine percussion petard, as applied to the destruction of sharks. It was constructed of paper made waterproof, having a brick about four pounds weight attached to its lower end, to cause the ignition of the charge of powder by the sudden pull on the cord which held the upper part of the petard; the cord was of the length required for the depth the petard was to explode in, being six feet; the sudden pull of the weight attached, caused the percussion which ignited the charge, on the petard being allowed to fall into the water. This petard, in all its varieties, can be adjusted (literally) on the hair or feather-spring guard. The other projectile was a paper hand-grenade, also waterproof, which exploded at the bottom of the deep water, by means of Pickford's safety fuze, primed at its upper end with a paste made of meal powder and spirits of wine. This was to demonstrate how fuze hand-grenades may be safely used for house defence. The annexed engraving represents this contrivance as hung *in situ*. A is an inclined tube, supposed to be fixed in the wall of a house, immediately over the door; 1 is a hand-grenade, fully charged, which

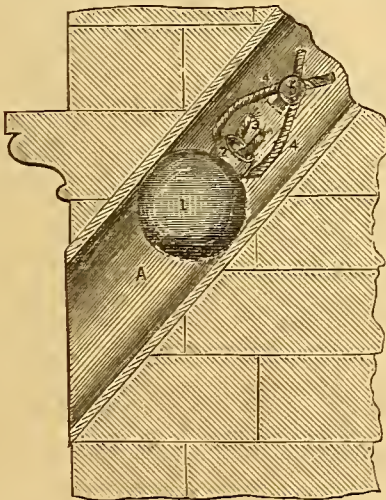

is suspended by a loop of twine, 4, or fusible wire, passing through the cap, 2, of the fuze, from a nail, 5, fixed within the tube. The end, 3, of the quick-match being lighted, the twine or wire will be almost instantly consumed, when the grenade will descend by its own weight down the tube, into the midst of the storming party. Instead of one such grenade, there may be a whole battery placed overhead. The windows, too, may be protected in the same way as the doors; and a house so protected would be impregnable for the few hours while it would be necessary to stand out before daylight and assistance arrived. The fuze may be lighted by a taper or port-fire; but Captain Norton recommends, as the simplest and readiest way, the application of a lucifer-match to the end of the quick-match, 3, in the same manner as lighting the wick of a candle. This may be effected also by pulling a wire, in the same manner as a bell-wire or cord is pulled. One of Palmer's Vesuvians is a still more sure, certain, and comfortable way of igniting the fuze, which may be a slip of Pickford's safety fuze, in length about three inches; and this may be inserted either in a plug of wood or cork, fitting closely the orifice in the grenade. Houses protected by these means would each become a little fortress, and greatly disconcert an invading enemy. In Spain, it was comparatively easy to clear the country parts of the enemy, because there were few houses to defend, almost all the inhabitants preferring to live in towns and villages; but when the British army invaded the south of France, that country was well studded with strong and well-built gentlemen's and farm-houses, and it was no easy matter to drive the French soldiers and other defenders out of them, although they were not provided with hand-grenades.

"Coming events cast their shadows before."

Two FACTS adapted to the present TIMES.—At the close of the Cork Harbour Regatta, Captain Norton caused his submarine petard, or catamaran percussion shell, in the character of the great sea-serpent, to be fired about six inches under water against a bulkhead suspended in front of the Yacht Battery landing-place. The gatekeeper of the Queen's College being previously instructed, inserted the percussion cartridge into the iron mouth of the serpent; he then seized him by the

waist, and pushed him against the bulkhead, when the serpent, being somewhat out of temper from such usage, spit fire and smoke. The fangs of the serpent, or the percussion head of the cartridge, are at the Cork Harbour Yacht House. The select committee at Woolwich, in their letter of the 31st May last, reported to the present Master-General of the Ordnance, that, "from the information which they possess regarding this petard, they do not consider it applicable to the service." It is the same percussion petard that Captain Norton practically exhibited some months ago at Haulbowline, in the presence of Admiral Purvis, Captain Quinn, &c., when, with a cartridge charged with two ounces of Augendre's gunpowder, a plank of oak seven inches and a half thick was rent in pieces. At the close of the regatta yesterday, Captain Norton also caused the representation of a loaded ammunition wagon to be exploded, by firing into it one of his malleable iron rifle fire-shots, or spinsters, the robes of which were of calico, boiled in a solution of nitre and vinegar. This being fired from his rifle of the same bore as the present military rifle, viz., fourteen to the pound—the object being to demonstrate, from this comparative delicate instrument, that rifle cannon, with similarly formed rifled shot, cast on Mr. Ommanney's principle of malleable iron, may be introduced into the British service. The committee at Woolwich, in their letter of the 30th June last, reported to the Master-General, that "they do not see sufficient probability of your shot being of practical use to the service, to justify their recommending experiments being made with them at the public expense." This shot will take full effect on an ammunition wagon at the distance of twelve hundred yards, as was proved more than a year ago at the Pigeon House sands, near Dublin, by J. C. Hannington, Esq., and is fully described in the *Practical Mechanic's Journal* of July last; also, in Captain Norton's Pamphlet. Captain Norton then fired one of his fuze hand-grenades, made of water-proof paper, having Pickford's fuze inserted, instead of the ordinary wooden fuze, at a depth of six feet under water; this was similar to the grenade fired under water, at the Upper Lee Regatta, and frequently on board the river and Queenstown steamers.

PATENT LAWS—ARTS AND SCIENCE—HARBOURS OF REFUGE—GEOLOGICAL MUSEUM—ORDNANCE SURVEY, IN SCOTLAND.—In the "Statement of Certain Scottish Grievances," just issued by the "National Association for the Vindication of Scottish Rights," we find the following:—

Patent Laws.—The terms of the "Patent Law Amendment Act" have not been complied with as regards Scotland, in so far that the copies of plans and specifications of patents, which it was therein enacted should be transmitted to and registered in Edinburgh, have (although frequently applied for) never been sent; and now, on pretence of the expense and trouble of copying the said plans and specifications, the bill has been altered, so as to deprive the Scottish people of all opportunity of inspecting those documents; and in actions before the Scottish courts, regarding the infringement of patents, copies of those papers must, like everything else, be obtained from London, at a much greater expense than they could be had for at home.

Arts and Science.—The sums already granted to the British Museum and National Gallery, for buildings and purchase of pictures and antiquities, amount to upwards of £3,000,000. Almost the only sum Scotland has ever received for a purpose somewhat similar, is one of £15,000, towards the erection of a building on the Mound of Edinburgh. The other £10,000 required for its erection was derived from the funded property of the Scottish Board of Manufactures. Last year £15,000 was granted to the College of Physicians, London, for the purpose of enlarging their theatre; and a few weeks ago additional grants of £28,000 for the British Museum, and £44,000 for the National Gallery, were voted and passed. The Royal Society, Dublin, receives an annual grant of upwards of £6,300.

Harbours of Refuge.—With a large and increasing commerce, Scotland has only one harbour of refuge upon her extensive coast. On our eastern shore, which is rocky, dangerous, and stormy, are the important seaports of Leith, Dundee, Aberdeen, and Montrose, yet from Berwick to Wick there is not a single harbour of refuge. On our western shore, where, by the number of bays and deep salt lochs, they are less required, we have one, viz., the harbour of Port-Patrick. This has been constructed, not with any regard for the commerce of our merchants, or the lives of our mariners, but simply for the safety of the Irish steamers, and the transmission of the Irish mails. In the Pentland Firth, the shores of which are covered with wreck-wood from Duncansby to Dunnet, there is not an available harbour, although the government are in possession of a report from their own surveyor pointing out the existing suitable harbour of Gills, which might be rendered completely efficient for a trifle. Along the dangerous coast of Kincardine and Aberdeen, such harbours of refuge are imperatively required for our Baltic shipping during the prevalent and stormy eastern gales. The harbour of Aberdeen is one of the most dangerous on the coast, as the recent wreck of the "Sutherland" steamer can testify. Scotland possesses about 30,000 merchant seamen; she has 4,000 vessels under sail, and 178 steamers, making an aggregate of 540,000 tons. In 1851, 24,661 ships from all parts of the world, whose gross tonnage amounted to 2,658,905 tons, entered the ports of Scotland; therefore, it is imperative that we should have harbours of refuge, and that this matter, so deeply affecting our shipping interests, should be forced upon the country. The estimated cost of the breakwater and other works at Jersey was £1,000,000; Kingston Harbour, Dublin, cost £819,000; while the whole sum given to Scotland in 1846, to build piers and harbours, was £238! By a Parliamentary return, just published, it appears that the following are the estimates for five harbours of refuge now constructing in England:—Dover, £245,000; Harwich, 110,000; Alderney, £620,000; Jersey, £700,000; Portland, £588,959; making a total of £2,263,959. For Holyhead, £91,270 has just been voted by parliament; and to repair the Scottish harbour of Port-Patrick, for the use of the Irish steamers, £2,556 have been given. In the face of such facts as these, the quiescence of the Scottish people is somewhat

remarkable. In the Admiralty report on the Glasgow Waterworks Bill, it is stated that "between the Humber and the Firth of Cromarty there is no other harbour or sheltered anchorage into which large ships of war can safely run for shelter or rendezvous, other than the Firth of Forth, and more particularly in the reach above Queensferry, where the shelter is complete; but as the Firth of Cromarty is away from any important interests, the Firth of Forth must be considered the only war-port north of the Humber, and therefore a most fitting place for a naval arsenal." It is further stated, that "Lieutenant Cudlip, R.N., who has made an excellent survey and chart of the Forth from Queensferry to Stirling Bridge, has stated, that on some occasions he has counted as many as 300 vessels at the anchorage off St. Margaret's Hope, either taking shelter or wind-bound there; and it is the most important harbour for men-of-war on the east coast of Great Britain."

Geological Museum.—Museums of geology have been established in London and Dublin, and a grant of £18,000 per annum has, for many years past, been given to these museums. The royal engineers are now employed in a geological survey of England and Ireland, and transmit to those museums plans and sections of the strata of different localities, together with specimens of the minerals. No such museum has been established in Edinburgh; no such survey of Scotland has taken place as yet. In the early part of last year, the Lord Provost, Magistrates, and Council of the city of Edinburgh, addressed a memorial to the Lords Commissioners of Her Majesty's Treasury, setting forth that, from various sources, the present distinguished professor of natural history had been enabled to collect geological specimens sufficient to fill a museum of much greater extent than the present extensive museum of natural history. These specimens include one of the most valuable collections for a geological museum which is to be found in the United Kingdom. But, for want of accommodation, these are piled up in cellars and attics, where, of course, the public can have no access to them. Some idea may be formed of the extent and value of that portion of the collection, which cannot now be exhibited for want of room, from the following enumeration of specimens at present so laid aside in cellars and attics:—1. Nearly the whole of the great geological geographical collection, consisting of upwards of 22,000 specimens. 2. About 4,000 specimens of the mineralogical collection. 3. About 10,000 specimens of organic remains. 4. A valuable collection of rare quadrupeds, many of them of the larger and most important species, which cannot be prepared for want of room. 5. A collection of 4,200 birds. 6. A collection of 500 fishes and 400 reptiles. 7. A collection of nearly 800 skeletons and crania of mammals, birds, reptiles, and fishes. 8. A collection of 500 invertebrate animals. 9. A collection of 3,000 specimens of recent shells, so important for practical geology. 10. Besides the above, there are many interesting collections made during the voyages of Captain Ross, Captain Parry, Lord Byron, Sir John Richardson, Captain Scoresby, and Captain Fitzroy, presented to the museum by the Lords of the Admiralty, none of which are at present accessible to the public, or even to the scientific inquirer, solely from the want of room to exhibit them.

Ordnance Survey.—The history of the ordnance survey is a history of injustice and neglect towards Scotland, and of partiality towards England and Ireland. The ordnance survey of England was commenced in 1791, and was continued, without interruption, until completed, at the expense of £750,000. The survey of Ireland was begun in 1824, and its progress was so rapid that, by 1845, the whole country had been surveyed, and the map engraved and published, at an expense of £880,000. The survey of Scotland was commenced in 1809, but was almost immediately suspended, in order that the persons then engaged in it might be employed in carrying forward the subordinate triangulation required for the detail maps of England. The survey of Scotland was not proceeded with until 1814, when the triangulation was resumed, and continued until 1823, when it was again interrupted, the instruments employed upon it being required to complete the survey of England. It was then again abandoned for 15 years. In 1838 it was resumed, and has struggled on until now. The sum expended on the Scottish survey, during the last 44 years, averages about £2,500 per annum. The Parliamentary Report, published in 1852, states that "Scotland, as regards its geography, is behind all the countries of civilized Europe." The map of Ireland was engraved in Dublin, giving Ireland the benefit of the whole £880,000; the map of England was engraved in Southampton, giving her the benefit of the whole £750,000. The map of Scotland is being engraved in England. Amongst much that is frivolous, there are some grievances in these matters.

SELF-EXHAUSTING SIPHON.—A novel and convenient form of siphon, for drawing off fluids of all kinds, without the necessity of any preparatory air exhaustion, has been simultaneously invented by Mr. J. A. Coffey, the pharmaceutical engineer of London, and Professor Lover of Dublin. The annexed sketch exhibits this simple contrivance. An elastic bag, B, is fitted to the siphon tube, and when the instrument is to be put in operation, the user, placing a finger on the lower end, A, of the tube, presses the bag, B. The air then passes out of the tube through the fluid, C, in the vessel above, and, on removing the pressure from the bag, B, the siphon at once commences to run. The experimentalist, who is accustomed to the use of siphons, will at once see the convenience involved in this modification.

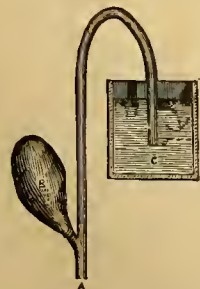

involved in this modification.

MAP-ROOM OF THE ROYAL GEOGRAPHICAL SOCIETY.—An important proposition, in reference to the practical value of the labours of the *Royal Geographical Society*, has just been made in the House of Commons by Mr. Hume. The hon. member

stated that a petition was presented on the 13th May from the Royal Geographical Society, praying for rooms to accommodate the society. Among the various scientific societies which existed, there was none more calculated to be useful than the Geographical Society, in a country where the knowledge to which that society applied itself was such as Englishmen, above all others, ought to possess. Their commerce extended to every part of the world; they had colonies in almost every part of the globe, yet they had no continuous plans of their colonies, though here and there they had excellent maps; and, taking the department as a whole, they were inferior to France and to Prussia—such instruction being given in the latter, and such statistical information communicated, as made a man acquainted with his own country. He had never spoken on the subject to any member, either of the last or of the present government, who had not acknowledged the importance of the department. The Royal Geographical Society had 14,000 or 15,000 maps; in ten or twelve different cases, discoveries had first met the public eye under its auspices; the Emperor of Austria had supplied them with a complete set of the maps of that country; and, having an ample supply of maps, they were perfectly willing to give every facility to the public at large for obtaining what information these could afford. Their request was, be thought, a reasonable one—that the public might assist them either with apartments, or with a sum sufficient to enable them to obtain proper apartments. Other societies had apartments which were supplied by the public; and, when parliament were prepared to spend so much on education, he did not think that £500 a year—the utmost outlay sought for the Geographical Society—could be regarded as ill applied. The petition to which he referred was signed by Sir R. J. Murchison and Lord Ellesmere, the president and vice-president of the society. In reply to this urgent solicitation, the Chancellor of the Exchequer stated that he was not prepared to say, on the instant, what steps it might be advisable to adopt in the matter, and that there were considerations which rendered it a difficult matter to treat the case apart from that of other societies, but that a favourable view would be taken of it, with the intention of granting reasonable aid for the purpose mentioned.

METALLIC TUBE MANUFACTURE.—Bower v. Hodges *et al.*—Action for Infringement.—This was an action on a covenant to pay a royalty of £4. 10s. per ton for the license to use a patent for making metal tubes, known as Prosser's patent. In March, 1840, Mr. Prosser obtained a patent for an improvement in the manufacture of iron tubes, and a license to use the patent on payment of a royalty of £4. 10s. per ton was granted by him to a Mr. Palmer; he also granted a license to the defendant, Mr. Selby, who was formerly in partnership with the plaintiff, but subsequently with the other defendant, Mr. Hodges, and the defendants were sued as licensees. Several models were exhibited in court, and Mr. Prosser and the foreman of the Birmingham Patent Iron Tube Company were called as witnesses. Mr. Prosser's process dispensed with the necessity for brazing the iron tubes used for locomotives and for other purposes, and, in the construction of gas tubes and gun barrels, the tubes were necessarily constructed shorter, and the iron was necessarily thicker before than since his invention. Mr. Prosser's process consists of three or four grooved wheels, in combination with a trumpet mouth-piece; and the mode of manufacture is to take the iron from the furnace, which is within six feet of the machine, and thrust it, while in a welding state, into the trumpet mouth, and the revolving wheels then fashion the pipe with much more rapidity and certainty than could otherwise be done. The defendants, it appeared, used two wheels only in combination with the trumpet mouth-piece; and as it was proved that a two-wheel roller machine alone was as old as 1817, and that the trumpet mouth-piece was used by itself on a draw-bench for turning up the "skelp" before Mr. Prosser's invention, it was contended that the combination of the mouth-piece with the two wheels rendered the machine used by the defendants different in principle from Mr. Prosser's; and, therefore, that no royalties had become due. For the plaintiff it was contended, that the principle of both machines was the same. The Chief Justice, in summing up, said, that several important questions would be reserved for the consideration of the Court of Error, but the simple question for them was, whether the defendants' machine was the same as Prosser's machine; he (the learned judge) had been concerned in cases relating to this patent, and had had occasion to witness the operation. It was originally difficult and expensive to make metal pipes; the plough iron originally was bent into a "skelp," and, by placing a mandrel under it, was hammered; the brazing, also, was an imperfect operation, and the ingenuity of mechanists was exercised to overcome these difficulties. Sometimes a tilt-hammer was used, acting on a "swage;" then Messrs. Jones and James, and, subsequently, Mr. Russel, used a roller; then followed the beautiful invention of Mr. Whitehouse; the furnace was close by, and the "skelp," in a heated state, was, by means of the draw-bench, drawn through an instrument called a scorpion, and the circumferential pressure produced the tube. Mr. Prosser's invention followed that. The learned judge then described, from the evidence, the nature of Mr. Prosser's machine, and of that used by the defendants, and left the simple question mentioned above to the jury. The damages were, by arrangement, settled at about £2,900, subject to a bill of exceptions. The ruling excepted to was, that—1. If the defendants' machine was substantially the same as Prosser's machine, the plaintiff was entitled to the verdict. 2. That it was immaterial whether the machine used by the defendants was new or old at the date of Prosser's patent. 3. That the patent did not restrict the use of the trumpet-mouth for making "skelps" only. 4. That the defendants were liable for making tubes by Prosser's machine.—The jury found their verdict for the plaintiff.

DRY MANURE FROM LONDON DRAINAGE.—A bill for establishing the *Great London Drainage Company* is at present before the House of Commons. It provides for the construction of two main sewers of enormous calibre, to carry the drainage of the metropolis to the neighbouring marshes, where it is to be converted into a marketable dry manure. An annual production of 100,000 tons, capable of use by agriculturists instead of the more costly guano, is looked for under this pro-

ject. The expense of the works, which, it is assumed, must otherwise be borne by the public, is taken at £900,000, on which the promoters demand a guarantee of three per cent. for 25 years. The scheme gives us some hope that we are on the brink of finding out how rich we are in fertilizing products at our own doors, without depending upon Ichaboe or Peru.

THOMSON'S AMERICAN MINING BORER.—The operation of boring a deep narrow hole in the earth for testing mineral resources, or the construction of Artesian wells, is one of the most tedious and expensive of engineering works. Very great depths are required, with very little room to get to them. Clay and sand choke up the boring instrument, whilst rock robs it of its penetrating edge, and turns it into a mere blunt log. The further the bore proceeds, the more the difficulties increase. The rods attain a fearful weight, with a correspondingly greater liability to break or become disorganized, and the clearing out of the tool becomes more troublesome. The common practice in this country is to bore on the auger principle, varying the tool from a screw point for loose soil, to a chisel edge for rock. The Chinese adopt a simpler plan. They use a weight armed with a cutter and suspend it from an overhead triangle by a rope, without any rods at all. With this they found their way into the earth, merely twisting the rope about to increase the effect and prevent wedging. It is on this latter principle that Mr. Thomson, of Philadelphia, has worked out his new borer. Our engraving represents it as boring through rock. The drilling-chisel, A, is attached to the end of the heavy cylindrical iron bar, B, of about five feet in length. The top of the bar has a swivel-piece, C, for connection with a four-foot bar, D, of a square inch in section, passed through an elliptical blade-spring, E, and hung to the rope at F. The spring is composed of four blade-pieces about 18 inches long, and curved to fit to the sides of the bore. A metal disc forms the top and bottom of the spring, the upper one having a square hole for the bar, D, to work through, whilst the lower one has a round hole for the same purpose. The upper end of this bar, D, has a twist of about a quarter turn upon it, and it carries an adjustable stop, G, set within the spring. In operating with this apparatus, all that is necessary is to elevate it about 18 inches at each stroke, by hauling up the rope, the spring remaining stationary in the bore, whilst all else moves up. Thus, the ascent of the bar, D, causes the cutter to twist partially round upon its axis, by reason of the traverse of the twisted part of the bar through the upper disc of the spring. In its elevated position, the stop, G, comes near the top of the spring, when the rope is slackened for the free fall, and the cutter, A, then falls directly in the position of its actual suspension at the movement, as turned partially round—that is to say, the cutter itself has no return twist, although the bar, D, goes back to the point whence it started. This arises from there being no friction upon the swivel in the descent, although in the ascent the frictional drag here is sufficient to carry round the bar, B. At the succeeding elevation, the cutter goes a degree further round its circle, and the spring is gradually carried down the hole as the hole deepens. This simple borer acts very satisfactorily—the extent of the turn, or the pitch of the cutter stroke, being easily variable by shifting the stop, G, up or down, to give more or less twist.

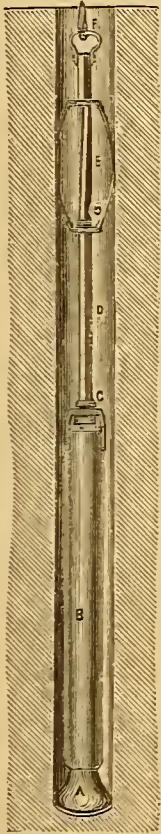

STEAM-WASHING FOR CLOTHES.—At the St. Nicholas Hotel, New York, is now to be seen a very complete system of steam-washing clothes on the grand scale, by which the articles are washed and dried, ready for the ironer in less than half an hour. All the washing of the hotel, amounting to from 3,000 to 5,000 pieces daily, is performed by one man and three women. The machine which they use consists of a strong wooden cylinder, four feet diameter, and four and a half feet long, mounted on a frame, so as to be driven by a band on one end of the shaft. This shaft is hollow, with pipes so connected with it, that hot or cold water, or steam, can be introduced, at the option of the person in charge. The cylinder being half full of water, a door at one end is opened, and 300 to 500 pieces of clothing are thrown in, with a suitable quantity of soap, and an alkaline fluid, which assists in dissolving the dirt and bleaching the fabric, so that clothes, after being washed in this manner, increase in whiteness, without having the texture injured. When the cylinder is changed, it is put in motion by a small steam-engine, and made to revolve slowly, first one way a few revolutions, and then the other, by which the clothes are thrown from side to side, in and out and through the water. During this operation, the steam is let in through a double-mouthed pipe—somewhat of the shape of the letter X—which has one mouth in and one mouth out of water; the steam entering the water through the immersed end, and escaping through the other, by which means it is made to pass through the clothes, completely cleansing them in fifteen or twenty minutes. The steam is now cut off, and the hot water drawn through the waste pipe, and then cold water introduced, which rinses the articles in a few more turns of the cylinder. They are now suffered to drain until the operator is ready to take them out, when they are put into the drying machine, which runs like a millstone: and its operation may be understood by supposing that millstone to be a shallow tub, with wire network sides, against which the clothes are placed, when it is put in rapid motion.

The air passing in a strong current into the top and bottom of the tub, and out of the sides, carries all the moisture with it into the outside case, whence it runs away. The length of time requisite to dry the clothes depends upon the rapidity of the revolving tub. If it should run 3,000 revolutions in a minute, five to seven minutes would be quite sufficient. When there is not sufficient steam to run the dryer with that speed, it requires double that. In washing and drying, there is nothing to injure the fabric. Ladies' caps and laces are put up in netting bags, and are not rubbed by hand or machine, to chafe or tear them in the least, but are cleaned most perfectly. It can readily be imagined what a long line of wash-tubs would be required to wash 5,000 pieces a-day, and what a big clothes-yard to dry them in; while here the work is done by four persons, who only occupy part of a basement room, the other part being occupied by the mangle and ironing and folding tables. Adjoining are the airing-frames, which are hung with clothes, and then shoved into a room, steam-pipe heated, when they are completely dried in a few minutes.

HENNAH & BOURNE'S DUPLEX EMBOSSEING PRESS.—This press, the invention of Mr. E. Hennah of Long-great simplicity and convenience of all spring movements, it in working. The engraving represents it in side elevation. The embossing mandrel or extremity, is squared to work fitally brackets, B, screwed at by the central lever-carries a toothed segment, D, testh on the upper side of the ported on a stud centre in screwed down to the stand. counterpart dies, or forces; and on drawing the lever back and vertically between the acting ment in one direction obviously other.

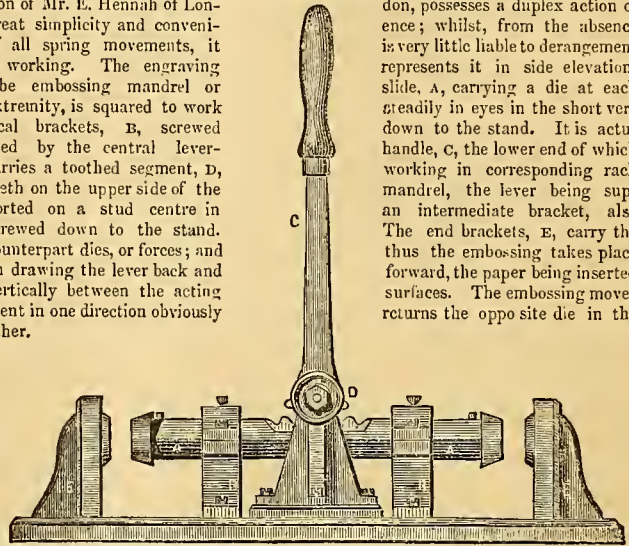

LITTLE'S SELF-REGULATING LUBRICATOR.—This lubricator, lately introduced by Mr. John Little, of the "Crystal Palace" Ironmongery Establishment, Glasgow, affords an easy and exact means of supplying oil or cooling fluids to machinery in motion, in a regular and uniform manner, and in direct accordance with the wants of the frictional surfaces, in relation to variations in the speed of working, without any extraneous attention whatever. Our illustration represents the apparatus in vertical section. The oil, or other lubricating matter, is supplied to a suitable reservoir, fitted with a strainer for detecting foreign matters, and in the bottom of this reservoir are one or more valves, guarding passages in communication with the rubbing surfaces. Each valve is connected to a short lever, hinged vertically to the bottom of the reservoir, and fitted with a spring tending to retain the valvular passage closed. The whole may be unscrewed from the inside of the cup, for cleaning, if necessary. In the upper part of the reservoir is a short horizontal spindle, carrying a cam, or actuating pin, for each valve—the pin in each case being contrived to press laterally, when required, against the upper end of the valve lever. One end of this horizontal shaft projects out at the side of the reservoir, and carries a pendulum lever, which is worked at each revolution of the shaft to be lubricated, by a pin or other projection on such shaft, or by such other means as the special movement may render necessary. Thus, as the working action goes on, the reciprocatory action of the pendulum works the valve levers correspondingly, and elevates the valve at each movement, so as to permit a small quantity of oil to pass through to the rubbing surfaces. Then, to regulate the quantity really discharged through, a small adjustable stopcock, or valve, is placed in the supply-pipe beneath, a spindle passing from such valve to a position suitable for the attendant, an index scale and hand being fitted up to show the extent of discharge opening. If cooling mixtures, such as sulphur, or other cooling compounds, are to be applied, they may be kept in a separate division in the reservoir, having a pipe communicating with the oil discharge-pipe, so that they can be supplied along with the usual lubricating matter as required. In the figure, the chamber, A, contains the oil, and in its bottom is the pipe, B, passing to the journal, this pipe having in it a stopcock, the spindle, C, of which runs along beneath the bottom of the reservoir, and carries the finger,

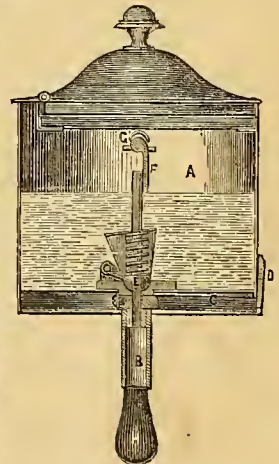

D, to show the extent of opening for the oleaginous flow. The working valve is at E, and as the lever, F, presses laterally on the upper end of the valve-spindle, as the shaft, G, is partially turned by the vibration of the pendulum, H, the valve is slightly lifted, and allows the oil to pass down to the bearing. In this way, a full, regular supply of oil is given to journals of any size, whilst the amount may be adjusted with the greatest nicety without any waste; and the supply starts, and is cut off, with the motion of the machinery itself.

ADAMS' RAILWAY CARRIAGE AXLE-BOX.—In an interesting paper, recently read by Mr. W. B. Adams before the Institution of Mechanical Engineers, the author brought forward the two forms of axle-box which we now engrave. Fig. 1 is a longitudinal section of an axle-box, showing as well a mode of applying moveable journals to axle-arms, either new or old. Thus the journal, A, may be forged down to a taper, with the object of extending the distance of the bearing on the wheel, or of increasing the diameter of the axle bearing. The moveable bearing, B, may be of wrought-iron, or cast-iron well got up, and case-hardened. In this way, manufacturers might be enabled to supply a superior class of axle-box and bearing at a cheap rate: and railway companies might thus cheaply replace their axles, when rendered unsafe by long vibration in running. The hollow axle, fig. 2, would be equally well suited for this arrangement. A conical tube of blocked leather, C, is secured to the box lip by an elastic ring, D, similar to a key-ring, and clipped to the axle by a second ring, E. Both the spring cone

Fig. 1.

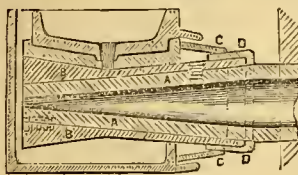
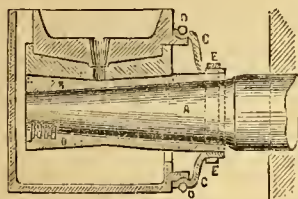

Fig. 2.

and the leather cone have free action, for accommodating any irregular movement of the box, preventing loose wear between them, the metal plate, and the leather.

PIPE AND BALL GOVERNOR FOR STEAM ENGINES.—Messrs. Cox and Wilson, of the Oxford Works, are now making portable oscillating steam-engines of a very simple and economical class, the piston being a solid plunger, directly jointed to the crank-pin, whilst the cylinder oscillates on trunnions, which are in themselves the steam ways. In these engines, the peculiar governor shown in section in our annexed sketch is used. It consists simply of a cast-iron or brass ball, A, placed in the steam-pipe, B C, which brings the steam from the boiler. At the governing point of this pipe it is tapered and curved upwards, a stop being set at C, to prevent the ball from getting so high up as to stick fast. The action of the governor is this:—As the steam rushes along the pipe, on its way from the boiler to the



actuating cylinder, it carries the ball along with it, and, as the latter ascends, it necessarily diminishes the area of the pipe through which the steam has to pass; and the higher the ball rises in the curve, the greater must be this reduction of thoroughfare, and the greater must be the steam pressure in its effect in counteracting the ball's gravity. This governor has been in use some time on a half-horse power engine at the Oxford Works, and it regulates the engine so well, that, when all the work is thrown off, it will not allow the engine to run more than 90 revolutions per minute.

MESSRS. DODDS' "YSABEL" LOCOMOTIVE.—The well-known "Lickey Incline," on the Birmingham and Gloucester line—a gradient of 1 in 37 for upwards of two miles—has just been the scene of a set of valuable experiments with a new locomotive, built by Messrs. Dodds & Son, of the Holmes Engine and Railway Works, Rotherham, for the railway of Isabella II., from Santander to Alar del Rey. The experiments were conducted under the superintendence of Mr. Stalvies, the locomotive manager at Bromsgrove. The load, at first, was made up of trucks and coke wagons, six in all, weighing 45 tons 12 cwt. 3 qrs., exclusive of engine or tender. Starting with the load from the Bromsgrove station, at the foot of the incline, the two miles one furlong were surmounted in twelve minutes twelve seconds; the speed of the engine increasing from forty-two to sixty-six strokes per minute, without slipping, although there was at the time a drizzling rain. The load was then reduced to 29 tons 4 cwt. 1 qr., equal to the weight of the passenger train the engine will have to encounter when on its duty. With this load the engine started, as before, from the bottom of the inclined plane, and ascended in seven minutes five seconds, being at the rate of eighteen miles per hour; the strokes of the engine also increasing, and no slipping. The engine has four wheels coupled, four feet six inches in diameter, weighing, with its complement of water, nineteen tons; the cylinders fourteen and a quarter inches diameter, twenty inches stroke. It is fitted with the patent wedge-expansive motion, and is so constructed that the cylinders, with the whole of the machinery, is attached to the frame complete, independently of the boiler, so that the boiler can be attached or removed in a few hours, the only joints having to be made being the steam-pipe and the two feed-pump connections. The boiler, therefore, is free for expansion and contraction. There are only two eccentrics, instead of four, and the moving parts are eight to thirty, as compared with the "link motion." The engine is also entitled to great commendation, from its great simplicity of arrangement, and the means of disconnection for easy transport over a mountainous country, no one part being more than 6 tons in weight when detached. The tender, containing 970 gallons,

weighed 5 tons 17 cwt.; blast pipe, 3 $\frac{3}{4}$ inches diameter, 137 tubes, 1 $\frac{1}{2}$ inches diameter, 11 feet 3 inches long. Such a test, with an engine never intended for running up inclines of this class with a load, cannot but be regarded as eminently successful.

THE ELECTRIC TELEGRAPH COMPANY OF IRELAND.—The recent report of this Company fully details the progress of the operations, and shows a very favourable state of affairs. An act of incorporation has been obtained, and the proceedings thus far have consisted in laying a double line of wire between Dumfries and Portpatrick, a distance of 73 miles; also from the Dublin Exhibition, through the streets of that city, to Glasnevin, and a considerable distance on the road to Drogheda, towards Belfast; and likewise from Belfast to Lisburn, Hillsborough, and Dromore. A new submarine cable is in preparation for the line from Portpatrick to Donaghadee; and the whole outlay thus far incurred on all the works of the Company, including preliminary expenses, is under £30,000.

PROVISIONAL PROTECTIONS FOR INVENTIONS

UNDER THE PATENT LAW AMENDMENT ACT.

When the city or town is not mentioned, London is to be understood.

Recorded April 26.

1000. John C. Hadden, Chelsea—Improvements in the manufacture of cartridges, and of wads or wadding for fire-arms.

Recorded May 21.

1260. Henri J. Scouteten, Metz, France, and 16 Castle street, Holborn—An improved plastic compound, applicable to various ornamental and useful purposes.

Recorded May 28.

1322. Henry C. Hill, Kingsland-road—Improvements in machinery and apparatus for the manufacture of hats, caps, and bonnets.

Recorded May 30.

1330. William Green, Islington—Improvements in treating or preparing yarns or threads.

Recorded June 4.

1375. John Chisholm, Holloway, Middlesex—Improvements in the production or manufacture of artificial manures.

Recorded June 6.

1388. John W. Friend, Southampton—An improved method of measuring and registering the distance run by ships and boats proceeding through the water, which is also applicable to measuring and registering tides and currents.

Recorded June 7.

1399. Alexander M'Dougall, Manchester—Improvements in the manufacture of potash and soda ash.

Recorded June 10.

1418. Henry E. Syrouds, Seacombe, near Liverpool—Improvements in preserving meat.

Recorded June 16.

1468. Peter A. Le Comte de Fontaine Moreau, Paris, and 4 South-street, Finsbury—Improvements in the preparation of certain vegetable and alimentary substances.—(Communication.)

Recorded June 17.

1480. James Hogg, jun., Edinburgh—Improvements in the application and combination of glass, porcelain, stoneware, earthenware, terra-cotta, composition in plaster, of the kind called scagliola, and majolica ware.

Recorded June 18.

1455. Guy Hannington, Holland-place, Denmark-street, Surrey—Improvements in producing railway and other tickets and cards.

1487. Jacques F. Dupont de Bussac, 36A, Upper Charlotte-street, Fitzroy-square—An improved mode of making, with iodine and its compounds, in combination with substances containing extractive principles, various elementary combinations.—(Communication.)

Recorded June 20.

1510. Robert Galloway, Cartmell, Lancashire—Improvements in manufacturing and refining sugar.

1512. Joseph Skerchely, jun., Kingsland, Middlesex, and Ansty, Leicestershire—Improvements in the application of baths to articles used for resting the human body.

Recorded June 23.

1531. Peter A. Le Comte de Fontaine Moreau, 4 South-street, Finsbury, and Paris—A new distilling apparatus.—(Communication.)

Recorded June 29.

1569. John Inray, Bridge-road, Surrey—Improvements in obtaining motive power.

Recorded July 4.

1594. Charles de Bergue, Dowgate-hill—Improvements in the manufacture of railway wheels.

1596. François Mathieu de Amezaga, Bordeaux—A method of obtaining motive power, and certain machinery or apparatus employed therein.

Recorded July 6.

1611. William W. Cook, Bolton—Improvements in the manufacture of woven or textile fabrics.

1612. Peter Gaskell, Manchester—Improvements in elastic springs.

1613. Thomas W. Kennard, Duke-street, Adelphi—Improvements in iron bridges.

1614. James Bradshaw and Thomas Dawson, Blackburn—An improved shuttle skewer.

1615. Robert A. Rust, Regent-street—An improvement in piano-fortes.

1616. John Woodward, Plat-street—An apparatus for curling hair.

1617. William E. Newton, 66 Chancery-lane—Improvements in locks and latches.—(Communication.)

Recorded July 7.

1618. Henry Bate, 3 Newhampstead-road, Kentish Town—Invention of a new fire-escape, which he denominates the "Ignivador."

1619. James Cheetham, junior, Manchester—Improvements in machinery for cutting fustians, velvets, and other similar fabrics.—(Communication.)

1620. Auguste E. L. Belford, 16 Castle-street, Holborn—Improvements in logs for indicating the speed of ships and other vessels.—(Communication.)

1621. Alexander A. Croll, East India-road—Improvements in apparatus used in the manufacture of gas.

1622. Christopher Vaux, Brixton, Surrey—Improvements in floating breakwaters.
1623. John K. Stuart, Glasgow—Improvements in hats and other coverings for the head.

Recorded July 8.

1624. Benjamin Dangerfield, West Broomwich, Staffordshire, and Benjamin Dangerfield, junior, same place—Improvements in constructing and fixing the rails of railways.
1625. Louis Cornides, 4 Trafalgar-square—Improvements in treating certain ores and minerals, for the purpose of obtaining products therefrom.
1626. William Marsden, junior, Longridge, Lancashire, and Samuel Roscow, same place—Certain improvements in looms for weaving.
1627. William Maddick, Manchester—An improved mode of treating madder and munnjet, by which the quality of the colouring matter contained in those substances is greatly improved, and its application to dyeing and printing much facilitated.
1628. William Robertson, Rochdale—Improvements in machinery or apparatus for preparing, spinning, and doubling cotton, wool, and other fibrous substances.
1629. Jacob Brett, Hanover-square—Improvements in photography.
1630. Louis Brunier, 21 Norfolk-street, Strand—Improvements in obtaining power by compressed air.
1631. Stephen M. Saxby, Brussels—Improvements in apparatus for lowering ships' boats, and for holding and letting go tackle.
1632. Moses Poole, Avenue-road, Regent's-park—Improvements in the manufacture of printing rollers.
1633. Philippe P. de St. Charles, Fulham—Improvements in apparatus for measuring and indicating the distance travelled by cabs and other vehicles.
1634. James Parkes, Birmingham, and Samuel H. Parkes, same place—Improvements in the manufacture of certain drawing or mathematical instruments, also in packing or fitting the same in their cases, which said improvements in packing or fitting are also applicable to the packing or fitting of other articles.

Recorded July 9.

1635. Thomas Restell, Strand—Improvements in walking-stick umbrellas, applicable also to parasols.
1636. Ewald Riepe, Finsbury-square—Improvements in the manufacture of tarret or clock tower, and such like bells.—(Communication.)
1637. Ewald Riepe, Finsbury-square—Improvements in moulds for steel castings.—(Communication.)
1638. Henry H. Peppin, New Bond-street—An improved joint for umbrella and parasol sticks.—(Communication.)
1639. Jean T. Boulé, Paris, and François Cailland, same place—Improvements in composing and distributing type.
1640. Frederick Meyer, Paradise-street, Lambeth—Improvements in the manufacture of candles and night-lights.
1641. Pierre A. Tourniere, St. George's-road, Surrey, and Louis N. De Mekenheim, Birmingham—Improvements in the manufacture of soap and washing paste, and of the materials used therein.
1642. Mark Spott, junior, Garnkirk, Lanarkshire, and Robert Denham, same place—Improvements in the manufacture of pipes or hollow articles from plastic materials.
1643. George P. Renshaw, Nottingham—Improvements in cutting and shaping.
1644. William Skinner, jun., Glasgow—Improvements in windows, shutters, and apparatus connected therewith.

Recorded July 11.

1645. George Ager, Witham, Essex—An apparatus for holding and turning over the leaves of music or music-books.
1646. Peter Fairbairn, Leeds—Improved machinery for heckling flax, hemp, china-grass, and other fibrous materials.
1648. Fabian Wrede, Stockholm—Improvements in gas and air engines.
1649. Henry B. Hopwood, 184 St. George-street East, Wellclose square—Improvements in ships' ports or scuttles.
1650. George Dalton, Lymington—Improvements in reverberatory and other furnaces.

Recorded July 12.

1652. Joseph B. Finnemre, Birmingham—Improvements in sofa springs, useful for spring-stuffed upholstery work generally, and in the adaptation thereof to mattresses.
1653. William Levesley, Sheffield—An improved method of making table-knife blades.
1654. Patrick Cowan, Skinner-street—Improvements in gas-fittings.
1655. John H. Johnson, 47 Lincoln's-inn-fields, and Glasgow—Improvements in the preparation of glycerine, and in its applications.—(Communication.)
1656. Andrew Burns, Glasgow—Improvements in constructing iron ships, boats, boilers, and other metallic structures.
1657. Martin Samuelson, Hull—Improvements in the manufacture of bricks and other articles from plastic materials.
1658. James Fletcher, Facit, near Rochdale—Certain improvements in machinery used for spinning, doubling, and winding cotton, wool, flax, silk, and other fibrous materials.
1659. William F. Snowden, Weymouth—An improved mangle.
1660. Nesserwanjee Ardaseer, Bombay—A method of driving shafting, so as to obtain two revolutions of a screw or other shaft to one revolution of a driving shaft, or to obtain the converse result.

Recorded July 13.

1661. Henry M. Grover, Hitcham Rectory, Buckinghamshire—A new method of finding and indicating the measurements of the sines and cosines of the arcs of circles or other peripheries.
1663. Thomas H. Bakewell, Dishley, Leicestershire—Improvements in ventilating mines.
1664. William Williams, 82 Fetter-lane—Improvements in electric telegraphic instruments.
1665. John L. Taberner, Lorn-road, North Brixton—Improvements in the manufacture of iron.
1666. Frederick Ransome, Ipswich—Improvements in the manufacture of artificial stone and similar wares.
1668. Alfred Fryer, Manchester—Certain improvements in the construction of apparatus for returning animal charcoal.

Recorded July 14.

1669. William Needham, Smallbury-green, and James Kite, younger, Princes-street, Lambeth—Improvements in machinery and apparatus for expressing liquid or moisture from substances.
1670. Sir Richard Brown, Chelsea—Improvements in coffins, catacombs, sarcophaguses, and cenotaphs.
1671. Augustino Carosio, M.D., Upper Montague-street—A new or improved electromagnetic apparatus, which, with its products, is applicable to the production of motive power.
1672. William Henderson, Bow-common—Improvements in the construction of furnaces for the purpose of obtaining products from ores.
1673. Richard A. Brooman, 166 Fleet-street—Improvements in the manufacture of anvils.—(Communication.)

1674. André L. J. Lechevalier, St. André, Regent's-park—Certain improvements in packing goods, so as to increase the facility and safety of their transmission from place to place.

1675. George Humphrey, Brighton—Improvements in regulating the supply of water for water-closets.
1676. Robert S. Bartlett, Redditch—Improvements in the manufacture of sewing machine needles.
1677. John Yule, Glasgow—Improvements in rotatory engines.
1678. William Little, Strand—Improvements in the manufacture of lubricating matters.
1679. Benjamin Looker, jun., Kingston-on-Thames—Improvements in the manufacture of bricks.

Recorded July 15.

1680. James Nasmyth, Patricroft, near Manchester—Certain improvements in the machinery and apparatus employed in rolling plates and bars of iron and other metals.
1681. George Gowland, Liverpool—Improvements in certain nautical and surveying instruments.
1682. Robert Gordon, Heaton Norris, Lancashire—Improvements in furnaces used with steam-boilers, for the purpose of consuming smoke and economising fuel.
1683. Henry J. D'Huart, France, and 16 Castle-street, Holborn—Certain improvements in the manufacture of pottery.
1685. Charles Liddell, Abingdon-street, Westminster—Improvements in moving boats on canals and rivers.
1686. Henry Nathan, Birmingham, and Solomon Elsner, Exeter—An improvement in spectacle and reading-glasses and pebbles.
1687. Henry Bessemer, Old St. Pancras-road—Improvements in the process of refining and manufacturing sugar.
1688. Charles Goodyear, Avenue-road, St. John's Wood—Improvements in spreading or applying india-rubber, or compositions of india-rubber, on fabrics.
1689. Henry Bessemer, Old St. Pancras-road—Improvements in the manufacture and treatment of bastard sugar, and other low saccharine products, such as are obtained from molasses and scums.
1690. Charles Goodyear, Avenue-road, St. John's Wood—Improvements in the manufacture of brushes, and substitutes for bristles.
1691. Henry Bessemer, Old St. Pancras-road—Improvements in the manufacture and refining of sugar.
1692. Isaac Taylor, Stanford Rivers, Essex—Improvements in machinery for printing.
1693. Charles Goodyear, Avenue-road, St. John's Wood—Improvements in the manufacture of pens, pencils, and instruments used when writing, marking, and drawing.
1694. Charles Goodyear, Avenue-road, St. John's Wood—Improvements in preparing india-rubber.
1695. Charles Goodyear, Avenue-road, St. John's Wood—Improvements in the manufacture of beds, seats, and other hollow flexible articles to contain air.
1696. Jean B. Jelle, Alost, Belgium—Improved machinery for dressing or polishing thread.

Recorded July 16.

1698. Edmund R. Fayerman, Shaftesbury-crescent—A method of, and instrument for, keeping time in music.
1699. Henry Lamplough, Gray's-inn-lane—Improvements in the preparation and manufacture of certain effervescent beverages.
1700. Jacques Rives, Paris—Improvements in trusses for the cure or alleviation of hernia.
1701. Benjamin Burrows, Leicester—Improvements in Jacquard apparatus.
1702. James Naylor, Hulme, near Manchester—Improvements in lamps.
1703. Samuel Colt, Spring-gardens—Improved machinery for boring metals.—(Partly a communication.)
1704. Marie G. A. E. le Coat de Kervégun, Paris—An improved construction of wheel for motive power and propelling purposes.
1705. John W. Duncan, Grove-end-road, St. John's Wood—Improvements in adhesive soles and heels for boots and shoes, and in apparatus used for preparing and applying the same.

Recorded July 18.

1706. Isaac Alexandre, Birmingham—Improvements in metallic pens and penholders.
1707. William Boggett, St. Martin's-lane, and William Smith, Margaret-street—Improvements in machines for cleaning and polishing knives.
1708. Peter Armand le Comte de Fontaine Moreau, 4 South street, Finsbury, and Paris—A new mode of equilibrating indefinitely the weight of atmospheres.—(Communicated.)
1709. Thomas Wood and George Wade, Sowerby-bridge, Yorkshire—Improvements in machinery or apparatus for opening, cleaning, carding, or otherwise preparing cotton, or other fibrous materials to be spun.

Recorded July 19.

1712. Peter A. le Comte de Fontaine Moreau, 4 South-street, Finsbury, and Paris—A new mode of fastening buttons to garments, and an improved button, and also in machinery for manufacturing the same.—(Communication.)
1713. Richard Dart and Edward Silverwood, 12 Bedford-street, Covent-garden—The adaptation of loom machinery to the purposes of embroidery for badges worn by the police, railway officials, and other officers, and which require a succession of figures.
1714. Charles Breese, Birmingham—A method of forming designs and patterns upon papier maché, japanned iron, glass, metal, and other surfaces.

Recorded July 20.

1715. John Robison, 66 Coleman-street—A new or improved apparatus for making tea and coffee, and other infusions or decoctions for chemical and other purposes.
1716. Moses Poole, Avenue-road, Regent's-park—Improvements in gas regulators.—(Communication.)
1717. Edwin D. Smith, Hertford-street, May Fair—Improvements in crushing and washing ores and earths.
1718. James S. Norton and Henry J. Borie, New Park-street, Southwark—Improvements in the manufacture of tiles and stairs from plastic materials.
1719. John D. Goodman, Birmingham—Improvements in lanterns.
1720. Philippe Poirier de St. Charles, Fulham—Improvements in stopping and starting vehicles.
1721. Alexander Cochran, Kirkton Bleachworks, Renfrewshire—Improvements in finishing muslin and other fabrics.
1722. James Mills, Lower Brook-street, Grosvenor-square—Improved machinery for propelling carriages.

Recorded July 21.

1724. William Birkett, Manningham Mills, Bradford—A method of cleansing or purifying and treating soap-suds or wash-waters, so as to fit them to be again used for the washing of wools and other similar matters.
1725. Simeon C. Mayer, Paris, and 16 Castle-street, Holborn—An improved domino bearer.

1726. William Thorp, Collyhurst, near Manchester—Certain improvements in machinery for finishing and embossing plain and fancy woven fabrics.
1728. Edward Cockey, Henry Cockey, and Francis C. Cockey, Frome, Somersetshire—Improvements in the manufacture or production of cheese.

Recorded July 22.

1729. James Murdoch, 7 Staple-inn—An improvement in stamping or shaping metals.—(Communication.)
1730. Alexander J. Ansten, Trinity-place, Wandsworth-road, Surrey—Improvements in the apparatus used in the manufacture of mould candles.
1731. Thomas Gray and John Reid, Newcastle—An improved mode of manufacturing files and rasps.
1732. John Gillam, Woodstock, Oxford—Improvements in apparatus for cleansing and separating corn, grain, and other seeds.
1733. George Spencer, 12 Mauor-road, Walworth, Surrey—Improvements in springs for carriages.
1734. Mary Ann Rylands, Kingston-upon-Hull—Improvements in yards and spars of ships and other vessels.—(A communication from her late husband, Joseph Ryland.)

Recorded July 23.

1735. Charles W. Manby, 3 Grove-villas, Finchley—An improved shaving-brush, to be called "the Traveller's Patent Shaving-brush."
1736. William Huntley, Riswarp, near Whitby—Improvements in engines worked by steam, air, or fluids.
1737. Auguste B. Lalande, Bordeaux, and 16 Castle-street, Holborn—Certain improved means for preventing accidents on railways.
1738. Frederick Warner and John Lee, Jewin-street—Improvements in water-closets and urinals.
1739. John Hall, Bedford—An improved mangle.
1740. James M. Napier, York-road, Lambeth, Surrey—Improvements in letter-press and other raised surface printing machines.
1741. Samuel Barlow, jun., Stakehill, and John Pendlebury, Crumpsall, Lancashire—Certain improvements in machinery and apparatus for bleaching or cleansing textile fabrics or materials.

Recorded July 25.

1742. Joseph B. Howell, Sheffield, and William Jamieson, Ashton-under-Lyne—An improvement or improvements in the manufacture of saws.
1743. Joseph A. Furt-de-Rostin, 4 South-street, Finsbury—A new mode of constructing floating bodies.
1744. Alexander Clark, Gate-street, Lincoln's-inn-fields—Improvements in regulating the speed and indicating the power of steam and other motive power engines.
1745. William Ireland, Leek, Staffordshire—Improvements in the mode or method of melting or fusing iron or other metals, and in the apparatus employed therein.
1746. James Collins, Oxford—Improvements in the manufacture of paper.
1747. Robert Bitten, Dartford, Kent—Improvements in apparatus for ascertaining and indicating the supply of water in steam boilers.
1748. Warren de la Rue, Bunhill-row, Middlesex—Means of treating and preparing certain tar or naphtha, and applying products thereof.
1749. John Ferguson, Heathfield Brick and Pottery Works, Glasgow—Improvements in kilns for baking or burning clay.
1751. William E. Newton, 66 Chancery-lane—Improved machinery or apparatus for stopping cables.—(Communication.)
1752. Alfred V. Newton, 66 Chancery-lane—An improved manufacture of cutting tools.—(Communication.)

Recorded July 26.

1753. John Dawson, Linlithgow—A new instrument or apparatus for the purpose of preventing fraud in drawing off liquids.
1754. Frederick Cole, 159 High-street, Camden Town—An improvement of the lithographic press.
1755. Frederick Cole, 159 High-street, Camden Town—Facilitating and improving the process of inking in printing.
1756. Alfred W. Money, Chudleigh, Devonshire—An improved hride.
1757. Thomas Banks, Derby, and Henry Banks, Wednesbury—Improvements in apparatus for retarding and stopping railway trains, which improvements are also applicable to vehicles travelling on common roads.
1758. Thomas Buxton, Malton, Yorkshire—An improved mill for grinding.
1759. Farnham M. Lyte, Florian, Torquay, Devonshire—Improvements in obtaining iodide of potassium when treating certain metals.
1760. Joseph Barrans, Peckham-lane, Deptford—Improvements in steam boilers.
1761. John Giblett, Trowbridge, Wiltshire—Improvements in the manufacture of woolen cloth and other fabrics.
1762. Lansing E. Hopkins, New York—An invention for the manufacture of bat bodies of fur and other like substances.
1763. Alfred W. Warder, 1 Sydney-street, Brompton—Improvements in gas stoves.

Recorded July 27.

1764. Francis Arding, Uxbridge—Improvements in thrashing machines.
1765. John Knowles, Manchester—Certain improvements in looms for weaving.
1766. Peter Armand le Comte de Fontaine Moreau, 4 South-street, Finsbury, and Paris—Certain improvements in the manufacture of tiles for roofing.—(Communication.)
1767. Ange Louis du Temple de Beaujeu, Paris, and 4 South street, Finsbury—Improvements in rotary engines.

Recorded July 28.

1768. Edward Herring, Southwark—Improvements in the manufacture of sulphate of quinine.
1769. Charles Cummins, 148 Leadenhall street—Improving clock escapements.
1770. John F. Stanford, 9 Arundel-street, Middlesex—An improvement in the method of draining dwelling-houses and open and enclosed spaces in cities and towns, where sewers and drains are now or may be hereafter constructed.
1771. Thomas Forster, Streatham, Surrey—Improvements in the manufacture of boots and shoes.
1772. Benjamin C. Brodie, junior, 13 Albert-road, Regent's-park—Improvements in treating or preparing black-lead.

Recorded July 29.

1773. Theodore Dethier, Pimlico—An improved machine for mortising, drilling, and boring.
1774. Griffith Jarrett, London—Improvements in machinery or apparatus for stamping or printing coloured surfaces.
1775. James Edward McConnell, Wolverton, Buckingham—Improvements in steam engines and boilers for marine purposes.
1776. James Mackay, Aighurth, near Liverpool—Improved apparatus for propelling vessels.
1777. William E. Newton, 66 Chancery lane—Improvements in depositing metals or alloys of metals.—(Communication.)

1778. William Wild, Salford—Improvements in machinery or apparatus for covering rollers used in the manufacture of cotton, and other textile materials, with leather, cloth, or other substances.

Recorded July 30.

1779. William T. Henley, St. John-street-road—Improvements in modes of protecting wires for telegraphs.
1780. George K. Douglas, Chester—Certain improvements in the permanent way of railways.
1781. William W. Cook, Bolton—Improvements in the manufacture of woven fabrics, and in the apparatus employed therein.
1782. George Ambler, Settle, West Riding—Certain improvements in machinery for preparing for spinning cotton, wool, and other fibrous substances.
1783. Patrick Ramsay, Glasgow—Improvements in the construction of tents.
1785. Peter Armand le Comte de Fontaine Moreau, 4 South street, Finsbury, and Paris—An improved method of producing an electric current.—(Communication.)

Recorded August 1.

1786. John Buchanan, Leamington Priors, Warwick—Improvements in propelling vessels.
1787. Henry Cadell, Dalkeith—A reaping machine.
1790. John Gray, Rotherhithe—Improved apparatus for consuming smoke.
1791. Philipp Schäffer and Frederick Schäffer, Brewer-street—An improvement in travelling bags.
1792. James P. Tracy, Salisbury, and John II. Tracy, Old street—Improvements in cutting, reaping, and gathering machines.
1793. John S. Perring, Bury, Lancaster—Improvements in the permanent way of railways.
1795. Augustus R. Pope, Massachusetts—A new and useful or improved electro-magnetic alarm apparatus, to be applied to a door or window, or both, of a dwelling-house or other building, for the purpose of giving an alarm in case of an attempt to open said door or window.
1796. Robert Grimthorpe, 63 Mornington-road, Regent's-park—Improvements in the manufacture of rivets and bolts.
1797. Charles May, Great George-street—Improvements in the manufacture of bricks.
1798. Richard Holme, Kingston-upon-Hull—Improvements in the manufacture of gas.
1799. Henry P. Vaile, Ashchurch, Tewkesbury—Improvements in reaping machinery.

Recorded August 2.

1800. John Bothams, Gravesend—Improvements in the manufacture of wheel tyres for locomotive engines and other carriages.
1802. William Perks, jun., Birmingham—A new or improved tap for drawing off liquids.
1806. Peter Armand le Comte de Fontaine Moreau, 4 South street, Finsbury, and Paris—An improved mode of regulating the electric light.—(Communication.)

Information as to any of these applications, and their progress, may be had on application to the Editor of this Journal

DESIGNS FOR ARTICLES OF UTILITY.

Registered from 14th July to 28th July, 1853.

- | | | |
|------------|------|--|
| July 14th, | 3488 | J. J. Welch and J. S. Margetson, Cheapside,—“Brace.” |
| 16th, | 3489 | W. Sharman, Melton Mowbray,—“Rake.” |
| 18th, | 3490 | G. R. Maenalley, P. Whitechurch, and G. R. Maenalley, jun.—Camden-town,—“Flushing-pan closet.” |
| 19th, | 3491 | J. Cole, Holborn,—“Case and stand.” |
| 25th, | 3492 | Cowley and Madeley, Walsall,—“Tap.” |
| — | 3493 | J. Barlow, King William-street,—“Meat screen.” |
| 26th, | 3494 | J. Warner and Son, Jewin-crescent,—“Grinding part of taps.” |
| — | 3495 | J. Coxter, Grafton-street,—“Scarificator.” |
| 28th, | 3496 | J. Purdy and J. Young, Commercial-road East,—“Carriage-handle.” |
| — | 3497 | Captain Collinridge, Brompton,—“Cygnet-hook.” |

DESIGNS FOR ARTICLES OF UTILITY.

Provisionally Registered, 21st July, 1853.

- | | | |
|------------|-----|---|
| July 21st, | 523 | W. Peplow, Stafford,—“Boot or shoe.” |
| — | 524 | W. Redgrave, Rickmansworth,—“Swimming armband.” |

TO READERS AND CORRESPONDENTS.

RECEIVED.—“Lecture Developing a New Philosophy of Physics,” by Robert Forfar.

W. D., Manchester.—Let him look again at the diagram, and compare the text with it a little more carefully. The question of “two fixed partitions” does not affect the point at all; it is the differential nature of the two a-ting surfaces which we have to consider. Whilst the high-pressure steam is acting directly from the boiler upon the outside or top of the small piston, the outside of the large piston being open to the condenser, and there being a constant vacuum between the two—it ought to be clear to him, that this direct steam action on the small area receives the advantage of the intermediate vacuum, because the large piston is balanced by a vacuum on both sides of it. So much for this movement. In returning, the intermediate vacuum still remaining, the contents of the small cylinder expand into the large one, and motion obviously ensues from the steam-pressure advantage on the side of the large piston; and it ought to be equally obvious, that the intermediate vacuum must give its help to the large piston, in aid of this stroke, because the two end steam-pressures are the same; and, therefore, the larger area gains. Our correspondent apparently forgets, in his laudable endeavour to account for the vacuum “exerting its power, first on one side, and then on the other,” that, in one position, there is full steam-pressure on the small piston, whilst there is a vacuum on the corresponding side of the large one; and in the reverse position, that the pressures per square inch, on these surfaces, are precisely the same, the intermediate vacuum remaining unchanged.

G. S., Mazas.—We cannot understand this inquiry; there is no such patent.

A REGULAR SUBSCRIBER, Liverpool.—There are various patents in existence for different kinds of cement, but the firm in question possesses no patent for exclusive manufacture of what is generally known by the term our correspondent uses. The original patent has long since expired.

ENQUIRER, Aberdeen.—There is certainly no loss of power. The theory itself is new to us; and more than this—it is baseless.

THE GREAT INDUSTRIAL EXHIBITION, 1853.

II.

"A government wiser than man's has provided, in the constant exertion of talent, for the increase of our race, and maintains a proportion between our wants and our progress. Every round we rise in the ladder leads to a higher; but our step is limited, or we should outstrip our needs by too prodigious a stride, and encroach on the rights of a future age."—QUARTERLY REVIEW.

IRISH FISHERIES, SUNFISH OIL, AND OYSTERS.—SERVICE'S ELASTIC BRAID MACHINE.—SMITH'S CHROMATIC PHOTO-PRINTING FOR WOVEN GOODS.—PROF. LOVER'S CONTACT-BREAKER AND ELECTRIC CLOCK APPARATUS.—FADEUILHE'S SOLIDIFIED MILK.—CROSSKILL'S PORTABLE FARM-RAILWAY; BARNETT'S PERMEABLE FLOUR-DRESSING MILLSTONE; FRENCH MILLSTONES.—SLOAN AND LEGGETT'S HYDROSTAT.—GWYNNNE'S CENTRIFUGAL PUMP.—MESSRS. BARTER AND BUSHE'S RAW-ROOT GRATER.—MESSRS. RITCHIE'S EXPANDING MOULD-BOARD BRILL PLOUGH.—MESSRS. HILL'S EXPANDING HORSE-HOE FOR TURNIPS.—MESSRS. GRAY'S PARALLEL LEVER SUBSOIL PULVERISER.—BOYD'S DOUBLE-ACTION SELF-ADJUSTING SCYTHE.

SINCE our last month's notes on the Irish collection, fortune has more than smiled upon it. Royalty has visited it, and its pecuniary receipts have mounted up to a point even beyond its promoters' fondest anticipations. With so pleasant a subject for reflection, we may all the more satisfactorily resume our examination of the show.

The department allotted to models and apparatus connected with the Irish Fisheries is extremely interesting, indicating, as it does, that some real attempts are being made to take due advantage of Ireland's vast fishing resources. Neglect and mismanagement of the fishing grounds and their produce, have all along existed to an incredible extent. All this comes out, as we examine the subject in connection only with what the Exhibition

lays before us. The history of the harpoon, for instance, shown, by the Inspecting Commissioners of Fisheries, as the instrument for taking sunfish on the Galway coast, lets out the curious fact, that although this peculiar fish, which visits the coast in large quantities in summer, and yields an oil particularly valuable for chemical and other purposes, has been so little looked after and cared for, that the Claddaghmen have actually sold its oil at the price of common train oil. All Irish travellers who have journeyed as we have done, by Macroom, Bantry, Glengariffe, and Kenmare, must well remember the noble river Kenmare, which opens up before them after the wild and circuitous ascent, and the tunnelled pass, dividing the counties of Cork and Kerry. Here is a magnificent river, with the finest possible harbour and fishing capabilities, supporting a mere hamlet on its margin. The wonder is, that it has not grown into a famous seaport town in spite of itself. But on this very spot the notable discovery has only just been made, that oysters may be grown with profit. Now, indeed, the gentleman who has established oyster beds there admits, that the space they cover is becoming twice as valuable to him as the best land in the district.

Messrs. Ashworth, who have recently become the proprietors of some Galway fisheries, have added a valuable chapter to the Exhibition volume, in the shape of some cases illustrating the modern system of producing salmon by artificial means. This is the first experiment of the kind in Ireland; and the success of the Messrs. Ashworth has instigated the Tay proprietors in Scotland to go and do likewise.

A model of a screw steamer, fitted out as a fishing smack, with suitable carrying wells, is another very important contribution. It is from the designs of Mr. Saunders of Billingsgate, and has been put in practice by Mr. Howard, the great fisherman of the northern sea, for the conveyance of lobsters and other fish, of which large quantities have hitherto been rendered useless by the detention of sailing vessels in contrary winds.

Mr. W. Service, of Rutland Terrace, Hornsey Road, contributes the ingenious "machine, with new stop-motion, for making elastic braid," shown in perspective in fig. 1. As pointed out by its catalogue name, this apparatus is employed for making a narrow elastic braid, for such purposes as parasol clips, encircling hands, and other little contrivances, where elasticity is necessary. It is the first machine capable of making an elastic braid of two distinct colours, to form a striped figure. Such braids are well adapted for embroidering children's dresses, and they are also suitable for edging "set figure" patterns. Being flexible, and of any thickness, such braid will work in any desired angular form. An important improvement in the present machine is, its possession of a

No. 67.—Vol. VI.

means of stopping when a thread breaks, as in the power-loom with the "weft protector," or when the hobbins are empty. In the old machines, when anything of the kind occurs, the motion of the entire machine is arrested, the strap being compelled to slide off the driving pulley as it best could. Such a crude arrangement is, of course, very destructive in its effect upon the driving strap, whilst loss of time occurs in picking up and rearranging the disengaged belt. But by the adoption of the general system used in power-loom weaving—that is, obtaining the actual motion from the working threads, and conveying such motion to the prime mover—a perfect self-acting plan of working is introduced. In the actual arrangement, a falling weight is allowed to come in contact with a stop in connection with the driving pulley when the thread breaks, and this throws a driving clutch out of gear, the starting lever at the side of the machine being thrown forward at the same time. To start the machine when the broken end is set right, the starting lever is pushed back, when the driving pulley is at once connected with the machine, and the braiding goes on as before.

Amongst the printed fabrics are some beautifully coloured goods, the tinting on which is entirely executed by the chemical action of light. This novel and elegant invention is by Mr. R. Smith, of Blackford, Perthshire, who styles the process, "Chromatic Photo-Printing." The principal colours which he produces are red, yellow, purple, blue, white, and green. In this new application of the actinic rays of light by Mr. Smith, for printing and dyeing, or rather staining, textile fabrics, the cloth, whether composed of animal or vegetable fibres, is first steeped in a chemical solution, then dried in the dark, and finally exposed to the effects of light, just as the photographer treats paper in the calotype process. The parts which are to form the pattern are protected by pieces of darkened paper, or negative photographs, flowers, leaves of plants, or other objects, as may be required for the device, attached to a plate of glass. The time necessary to secure the proper effect varies from two to twenty minutes, according to the special nature of the process and the subject in hand; and after the exposure, the portion of the fabric which has been thus treated is removed, to undergo the "fixing" operation; that is, to destroy the evanescent nature of the newly-produced tints, and bind them down as "fast colours." Whilst this secondary process goes on, a new blank portion is exposed to the light, and thus the printing is effected in a continuous manner; a number of the chromatic photo-printing machines being ranged side by side, and superintended by a single operator.

It has been shown by the trials already made, that the light of even a cloudy winter day is sufficiently powerful for the purpose. Specimens

Fig. 1.

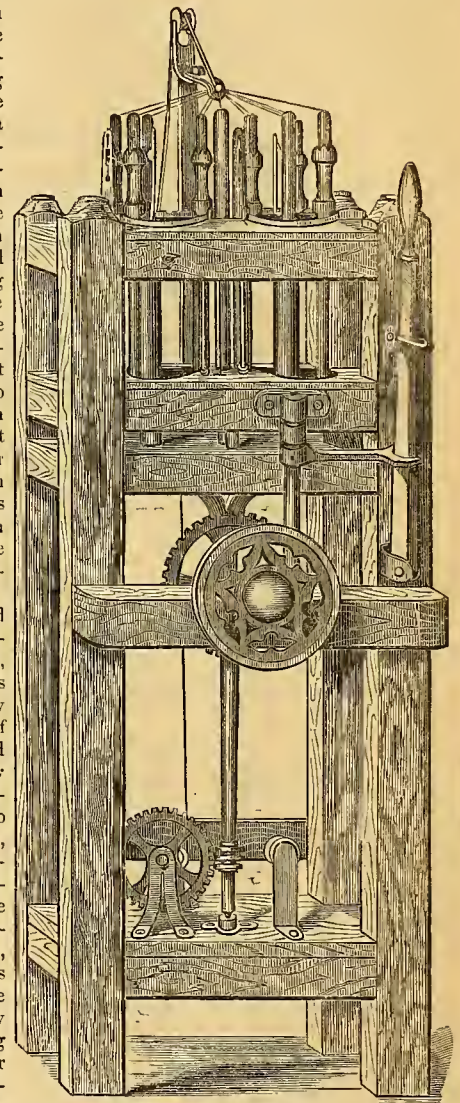

of exceeding beauty have been taken so late as four o'clock on a January afternoon—more time, of course, being necessary than with a bright and sunny summer sky.

To obtain a pale blue or white figure upon a blue ground, the inventor employs solutions of citrate or tartrate of iron, and ferro-cyanide of potassium, the cloth being afterwards steeped in a dilute solution of sulphuric acid. Browns and buffes are obtained from a solution of bichromate of potash, the excess of the salt in the parts not acted upon by the light being afterwards either washed out—leaving such portions white—or decomposed by a salt of lead, forming a yellow chromate of lead. By combining these two processes with the use of madder, log-wood, and other dye-stuffs, a great variety of tinting is obtainable. Fig. 2 represents this chemical printing-machine in perspective. It

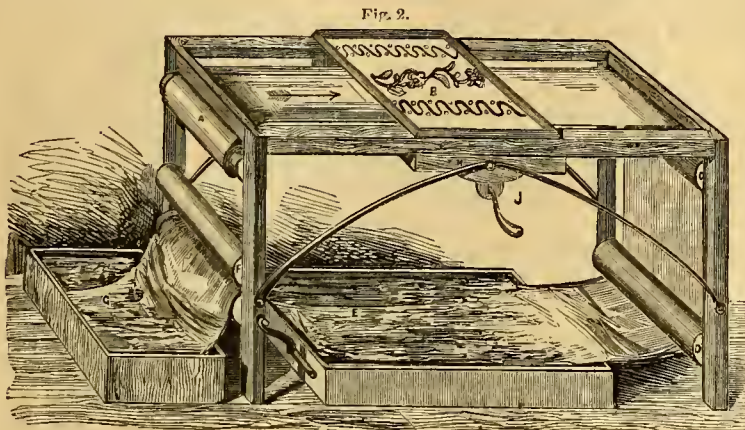

Fig. 2.

consists of a simple rectangular frame, fitted up like a plain table, having at one end a beam, A, on which the prepared cloth is wound. From this beam the cloth passes in the direction of the arrow, beneath a glass plate, B, on which the pattern is formed, in the manner we have described, by a combination of transparent and opaque portions. After each length has been exposed to the pattern action of the light, it is passed onwards, and thence round the guide-rollers, C, D, into the trough, E, containing the solution for developing the impression, either pure water, an acidulous solution, or a solution of ferro-cyanide of potassium being employed, to suit the sensitive preparation of the fabric. The piece is drawn through the developing trough by the pair of nipping rollers, F, worked by a winch-handle, and it is finally deposited in the water-trough, G, for being washed, to complete the process. At H is a cushion, composed of deal-board and several folds of flannel, and a spring is placed beneath each corner of the cushion-board, in order to keep the prepared fabric well up, in close contact with the lower surface of the pattern-glass. To the centre of this cushion-board is attached the end of a lever, working on the fulcrum, J.

When the machine is organized for working, a portion of the cloth is exposed to the light passing through the pattern-glass; and so soon as the exposed surface becomes white or brown, just as may result from the particular sensitive preparation in use, the pressure lever is raised, and the cloth is drawn through by its nipping rollers, carrying away the part with the embryo pattern upon it, and bringing forward a new length, to be similarly treated. This is continued until the whole length of the piece has been ornamented, in the gradual steps which we have explained.

In the most recent trials, this system of printing has been worked out on the full scale of the printfield, and whole dresses have been ornamented by it with facility and success, natural objects being impressed upon the goods in the loveliest colours obtainable by art.

In addition to these light prints, Mr. Smith exhibits a piece of calico, rendered fire-proof, by a new chemical process of his own. The details of the treatment are a secret, but the routine is simply the washing of the goods in water, holding a protective powder in solution. If expense does not stand in the way, this fire-proofing process ought to come into general use, as affording satisfactory security against the accidental catching fire of children's and ladies' dresses. The treatment does not at all affect the texture or colours of the fabrics. Mr. Smith is also the exhibitor of a series of interesting specimens of photography, obtained by the Prussia-type and Irio-type, the manipulatory details of which branches of art-manufacture have already appeared in our pages.*

A most interesting collection of educational models is shown by Dr. Lover of Dublin, a philosophical preceptor, to whom the youth of our times are largely indebted. In his working model of the electric clock he has a novel "contact-breaker," which we have engraved at fig. 3. In that illustration, the vessel, A, supplied by the stopcock, B, and fitted with an overflow-passage, C, filters water into the chamber, D, beneath, containing a float-valve, E, which retains the water constantly at the same level. A glass case, F, screens the whole of the working mechanism from dust and external influences. On opening the stopcock, G, at the bottom of the vessel, D, the strain of water upsets the tilting-

bucket, H, bringing its platinum pin, I, in contact with the platinum, J, on the base below, thus making contact. This is the position which we have chosen in our figure; and as matters now stand, contact is broken by the now upper division of the bucket getting filled. This double operation can be made to occupy exactly a minute. The arrows indicate

that a current of voltaic electricity can be established each minute, and thus an electric clock can be easily set in action. The simplest electric clock movement, the original invention of Mr. Bain, is represented in fig. 4. An electro-magnet, A, being set in action by galvanic contact, its armature, B, is attracted towards it, turning on the fixed centre, C, and thus the pallet, D, is pushed over one tooth of the ratchet-wheel, E, of 60 teeth. When contact is broken for the intermittent suspension of the electric action, the spring, F, of uniform tension, draws back the armature, and at the same instant pulls the ratchet-wheel one tooth forward, in the direction of the arrow. Dr. Lover's contact-breaker effects this every minute. To the axis of the ratchet-wheel is

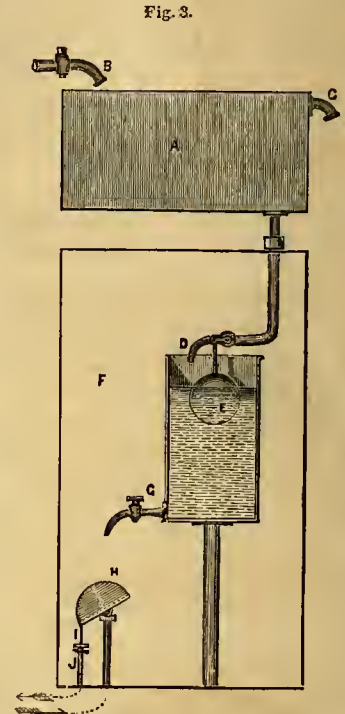

Fig. 3.

connected to the movement of a clock, indicating hours and minutes, and he thus possesses a perfect time-measurer, without the encumbrances of pendulum, weights, spring, or balance-wheel. It is, perhaps, hardly necessary to mention, that intermediate electric clocks may all be actuated at the same instant, for the purpose of establishing uniform time in localities distantly sundered.

Dr. Lover has also contrived another novel contact-maker for electro-magnetic machines, where rapid action is essentially necessary. This is given in fig. 5, where a small "Barker's mill," or reaction water-pressure wheel, A, has a hinged piece of platinum foil, B, attached to the under side of one of its lower arms. As the mill revolves on its vertical spindle, the platinum, B, touches platinum pins, C, set in an ivory circle in the path of the arms; and these pins are alternately connected with D and E, so that two electro-magnets can be kept in alternate action, removing the usual defect of having the contact-breaker on the machine

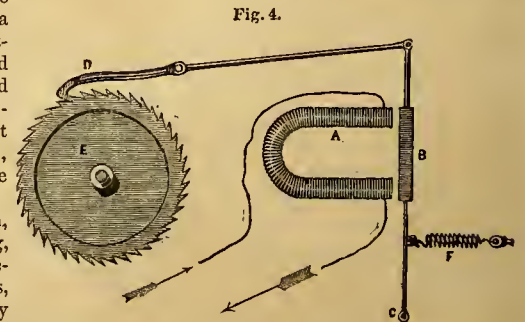
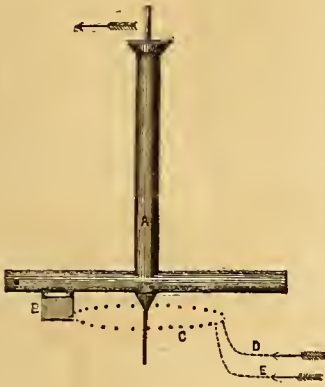

Fig. 4.

* See pages 202 and 222, Vol. I., *Practical Mechanic's Journal*.

itself. The curious pump-like action of the heart, is also well illustrated by Dr. Lover in a novel manner.

Fig. 5.



In "Substances used as food," M. V. B. Fadeuilhe, of Newington Crescent, London, shows samples of "Patent solidified milk, the grated substance of solidified milk, and the graters" used in the manufacture. Some of the grated powder is now before us, and we have made excellent cream and milk from it, by the mere addition of boiling water. The reduction of milk to a solid condition, and the extraction of all gross and corruptible matter, so as to enable the essence of the article to be preserved for a length of time, has been a difficult task, and has engaged the close attention of many inventors.

M. Fadeuilhe, indeed, tells us that he has spent seven years upon it. The raw material, cows' milk, is one of the most delicate animal substances, requiring peculiarly careful treatment for its purification and solidification, to make it capable of resisting the effects of variable climates, with a facility of liquefaction in a sweet, nutritious state, after long keeping. The grand agent in the transformation by M. Fadeuilhe's process is steam-heat, combined with agitation, the chief point being the nice regulation of the heat at the different stages of the process. The plan of a portion of M. Fadeuilhe's works, fig. 6, is sufficient to indicate the general arrange-

Fig. 6.

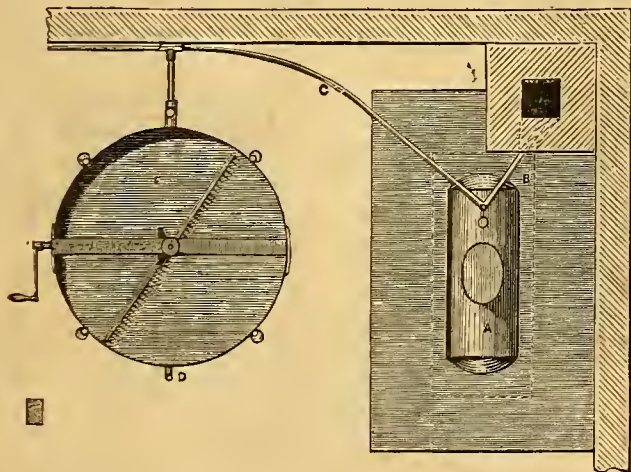

ment of the simple mechanism which he employs. The steam-boiler, A, occupying a corner of the building, is fitted with two pipes, B, C—the first passing to the safety valve, and the second to supply the range of heating and agitating pans, F. These pans are wide vessels, fitted with a common rotatory agitator, resembling that used in the paper manufacture; and after the milk has been properly heated and worked in this way, the fluid is discharged by the valve, D. When the milk happens not to be quite fresh, or to be the production of a newly-calved cow, the operator discovers that something is wrong at the second heating, when the heat reaches 160° or 170° Fahrenheit, for it invariably curdles. Such milk, or milk rendered unwholesome from any other cause, cannot be solidified, so that here is an effectual check upon the use of an improper material.

The perfect preservation of the solid matter in an available form, and the almost instantaneous liquefying power, is to be attributed to the separation and complete extraction of the grume, a thick viscid matter, always present in milk, and the removal of which has been the cause of so much trouble. The whey, or thin serous part, is got rid of by evaporation, after the primary purification of the milk; and all that is necessary after that, is the nice regulation of the heat and agitation, to secure the required solidity. The exhibited specimens are in the form of firm tablets, one pound of which contains eight pints of milk. To reduce

these solid masses for use as required, the inventor uses a rotatory eyllinder grater, the steel points of which bring the cake into a condition resembling sago flour, but of a creamy tint. Thus, a large supply of the solid milk may be gradually used, whilst the mass from which the consumed portions are taken is left unimpaired. The new material is in use both in the English and French navies, and Sir Edward Beheher's Arctic expedition has been supplied with it. A report, obtained at the instance of the French Government, states explicitly that the solid material possesses all the properties of cows' milk, with a very slight addition of gum and sugar.

Mr. Crosskill of Beverley, as usual, occupies a large area of exhibition space. His "portable farm-railway," made of red deal, edged with iron, in 15 feet lengths, of 30 inch guage, is amongst the most useful articles in the collection. It is evidently a good practical thing for conveying manure to, and taking green crops off, the land. In taking turnips off with it, 100 yards clears a quarter of an acre, the turnips being gathered for six yards on each side of the rails. Each truck carries 10 or 15 cwt. of turnips, and when one spot is cleared, two boys can shift the line 100 yards further on, and lay it ready for use, in ten minutes. Hussey's and Bell's reapers are here side by side, but we have already described both. Mr. Crosskill also brings forward Barnett's permeable millstones, as capable of dressing a great portion of the flour during the actual grinding process. Fig. 7 is a sketch of this stone. As soon as the grinding has commenced, the fine flour which is liberated passes over a set of radial wire-gauze openings in the lower stone, and the coarser particles are thus separated from the finer ones. In the upper stone, a series of openings are so arranged, and furnished with air-boxes, facing the direction of the stone's revolution, that the external air is forced down upon the grinding surfaces, to cool the meal, and facilitate the passing of the superfine flour through the wire-work in a cool state. The inventor alleges that he can thus separate a superfine flour from ordinary wheat, from one to two-thirds being delivered, ready dressed, into the bag, the rest being ready for immediate dressing.

Fig. 7.

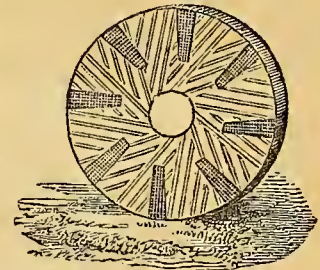

Messrs. Kay and Hilton, of Liverpool, are also exhibitors of some capital French burr runner millstones, built after the plans of G. Mullin, Esq., of Gilford, Down, and John Steel, Esq., Cork. Mr. Mullin's "Ring millstone" has been already engraved at page 38, Part 50, of this Journal.

By far the best millstones, used in this or any other country, are made of French materials; hence the examples of this manufacture, in the French section of the building, command especial attention. Four stones are shown by Messrs. Gaillard, as the produce of the quarries at La Ferté-sous-Jouarre. The stones from the valley of the Marne have the credit of performing more work, and turning out better and whiter flour than any others. They are purely siliceous in composition, and slightly tinged with ferruginous matter; they are now exported to every part of the world where the British system of grinding is followed. Formerly, great pains were taken to extract enormous stones from the quarry beds, to be used either as monolith grinders, or two or three only, combined into one, in a very rude manner, open faeces being selected to grind upon, instead of the modern artificial furrows. The grand improvement of cutting furrows in the grinding faeces, in such way as to improve the grinding action, without interfering with the centrifugal effect, is an English invention, introduced only forty years ago. Hence the uncertainty attending the use of porous or partially cellular stones was removed; and the French makers gradually improved upon the idea, by building up together small fragments of stone of equal hardness, so as to insure a good grinding surface throughout—this being unattainable in large masses, where softer and more porous parts frequently occur alongside the border areas. The makers thus contrived to get composite stones, each increment of the surface of which was of the same grain, hardness, porosity, and colour; and as the manufacture grew up to be an important branch of industry, the niceties of suiting the materials to the peculiarities of the country where the stones were to be used, the special system adopted by the millers, and even the character of the grain to be reduced, were all carefully attended to. Thus it is that the millstone manufacture has become a precise art. In building such stones, the workman selects a solid centre-piece, or eye-stone; and round this he sets his choice-selected

masses, previously bound together, and fixes the whole with plaster of Paris, such accuracy being observed in the fittings, that the entire structure hardly exhibits a joint. The smith then encircles the stone with a

Fig. 8.

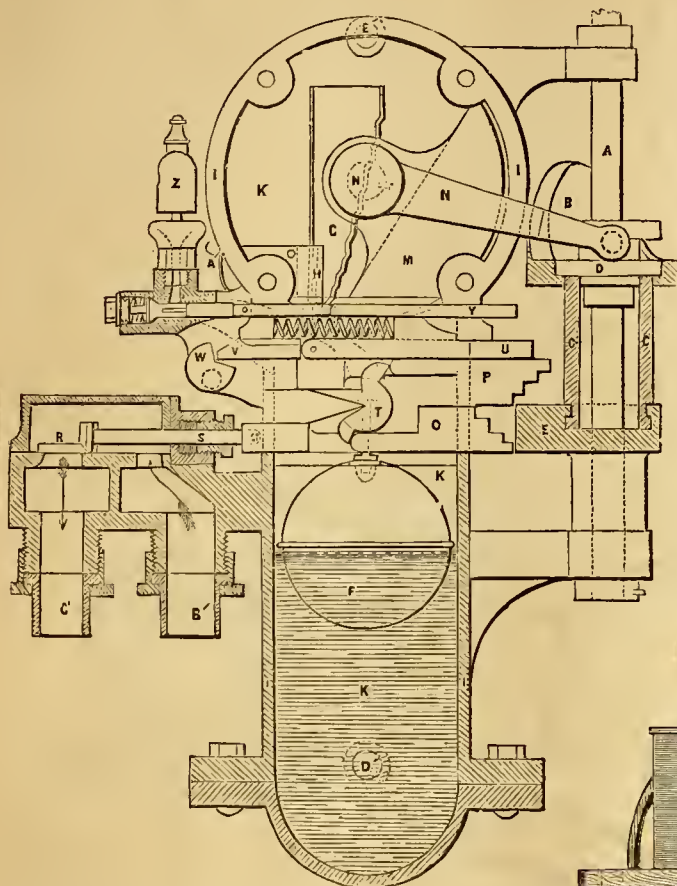

retaining hoop of wrought-iron, put on hot, so as to fit tightly on cooling. The dresser then reduces the yet uneven surface to a plane; and the furrow-cutter follows the dresser, first setting off, and then cutting out, the grooves which are to produce the sharp cutting edges. The eye is then completed, and the running stone balanced, to be of equal weight all round, cavities being left for the insertion of lead, when the stone is started in work, so that it may run with perfect steadiness. A second hoop of cold iron is then added to give further strength, and the stone is left to dry.

M. Roger, a French maker of repute, produces annually some 500 mill-stones, and an immense number of the inferior or burr stones—all excavated from the valley of the Marne.

Messrs. Sloan & Leggett's "Hydrostat for preventing steam-boiler explosions," is the production of the well-known Empire Iron Works, New York. Its power of preventing explosions is limited to the keeping the boiler water at a constant level, or within an allowably small range. But it thus goes to the very marrow of the most fertile source of these casualties. It does not supersede the usual feed-pumps, but is itself placed between the pumps and the boiler, as a safe regulating valve. Fig. 8 is a vertical section of the contrivance, as fitted up for use outside a steam-boiler. The vertical shaft, A, driven by the engine, revolves about four times a minute, carrying round with it the cam, B, in which are two curved openings, having two slides, C, attached to the grooved collar, D, passed through them. The lower ends of these slides carry a second cam, E, loose on the shaft; to the copper float, F, is fastened a composition-metal blade, G, having a flange on each side, serving as a guide in passing through the slotted rest, H, fast to the interior of the casing, I, which forms the steam and water chamber, K, with its water and steam connections, D' E'. The dotted line across the float, F, indicates the water-level, the float holding the indicator, G, with its lowest step opposite the edge of the weight, M; a shaft, forming part of this weight, is

passed through a stuffing-box, in the outside of the front plate, enclosing the steam chamber; and on this shaft is keyed a lever, N, having a pin resting on the cam, B, and fitting into the groove in the collar, D. As the shaft, A, revolves, the cam, B, coming in contact with the pin, raises the pin to the highest point, lifting the grooved collar, with the slides, C, and the cam, E, and relieving the indicator from the weight of the piece, M. As the cam, B, still moves, the arm, N, and grooved collar fall gently, until the edge of the weight, M, again touches one of the steps of the indicator, thus making the position of the cam, E, dependent upon the elevation or depression of the float. The notched slides, O R, are fitted to work freely in a chamber cast through the apparatus, and are screened from the steam. They are so connected with the supply-valve, N, governing the communication between the two branches, B' and C', of the feed-pipe, that when R is pushed in by the cam, E, the valve is opened; and when O is pushed in, the valve is closed. The slides are connected by a piece, T, on a wedge centre, to cause one slide to come out in proportion as the other is pushed in. The water-level is shown high in the figure. If it falls at each succeeding revolution of the shaft, A, the weight, M, will rest on a higher notch of the indicator, causing the cam, E, to rise accordingly. This gradually presses in the slide, R, until the supply-valve, N, is wide open; and if the water still continues to fall, the cam, E, is raised still higher, pressing in the slide, U; and this slide, through the catch, V, and boss, W, causes the hammer, X', to strike a bell behind the apparatus, to alarm the engineman. If the attendant then does not apply a remedy, the cam, E, is elevated still more, to press in the stem, Y, and sound the whistle, Z, when the supply is restored, the float rises, and the parts assume their original position.

Messrs. Gwynne, Son, & Co. have a clear field for the exhibition of their excellent centrifugal pump. It is in constant operation, and does an amazing amount of work with a comparatively small expenditure of power. The exhibited pump discharges 1400 gallons per minute. As another application of centrifugal force, Messrs. Rotch, Finzel, & Co. show their centrifugal sugar machine, for separating the crystals of sugar from the molasses and watery particles of the sirup.

The patent root-grater, by Dr. Barter, of Blarney, and Mr. Bushe,

Fig. 9.

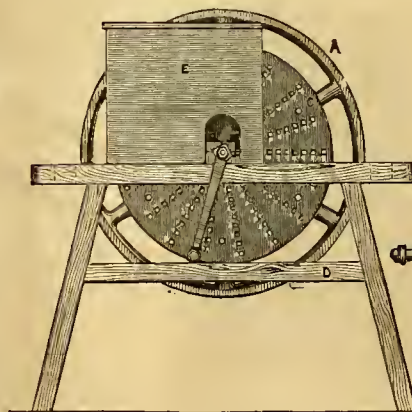
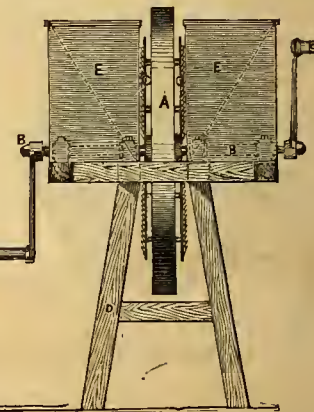
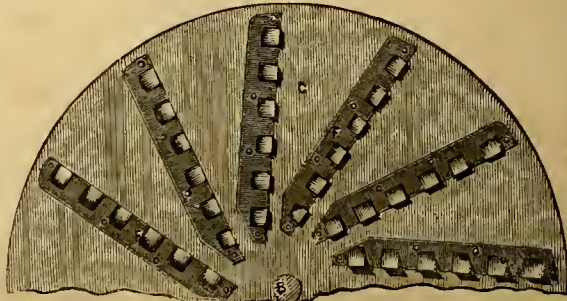

Fig. 10.



of Lismore, is a useful machine for reducing roots of all kinds. The inventors, themselves agriculturists on the large scale, having become impressed with the advantages to be derived from using raw instead

Fig. 11.



of cooked roots for feeding stock and poultry, have devised this means of pulping vegetable matter, so as to be available for such a system of feeding. Fig. 9 is an external side elevation of the apparatus; and

fig. 10 is an end elevation to correspond. Fig. 11 is a face view of the cutting disc; and fig. 12 represents the cutting edge of the knives. It consists of a heavy metal wheel, A, with six arms, mounted upon a shaft, B, and having on each side an iron disc, C, with cutting surfaces facing outwards. The discs are connected together transversely by six iron rods, one passing through each arm of the wheel, and riveted to the disc on each side. These rods are six inches long, so as to leave on each side of the wheel, between the wheel and the disc, a space sufficiently wide to allow the pulp to fall away when formed. The wheel and discs, thus combined, form a drum, capable of being driven by end winch-handles

Fig. 12.

towards the cutting surfaces. The cutting disc, No. 1, fig. 11, is armed with 12 steel knives, F, riveted to the disc—a portion of the disc under each knife being cut away, to allow the root, when cut, to pass away laterally through the disc. This cutting action severs the roots into long pieces, of a section $\frac{1}{2}$ inch by $\frac{3}{4}$, suitable for feeding sheep. The other disc, No. 2, contains 18 rows of cutters, forming an aggregate collection of above 150 cutting surfaces. The cutters are formed by punching square holes in the iron, and then cutting the iron through at the two corners of the hole, and turning it up, filing the edges. This secondary disc pulps or shreds the roots into shavings, $\frac{1}{2}$ inch wide, of the thickness of a shilling, fit for pigs, horses, and fowls. Major Bushe has made a very successful experiment in feeding pigs with his raw pulp—the economy of the plan comes out very strongly. The grater has deservedly obtained a first-class medal from the Royal Irish Agricultural Society, at the Killarney Show, in August last.

Messrs. W. & J. Ritchie, of the Implement Works, Ardee, Lonth, have a most satisfactory collection of agricultural machines, consisting of a "farm-cart, with harvest-frame and improved locker; six-drillcorn-sowing machine, with self-acting coulter; two-horse swing plough and subsoil plough; drill plough, with improved mode of expanding and contracting the mould-boards; and a new machine for ribbing wheat, oats, and barley."

The adjustment as to expansion and contraction of the mould-boards in the drill plough, is neatly and conveniently managed by a small winch-handle on a short screw spindle, running longitudinally between the stilts, directly before the ploughman. This screw has a nut fitted upon it, from which a connecting-rod passes at an angle, on each side, to the inner face of each mould-board.

Fig. 13.

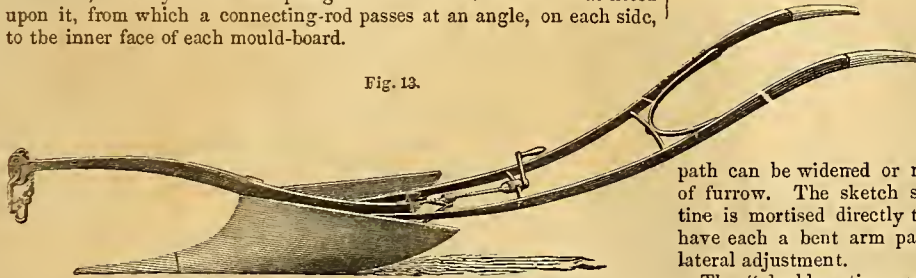
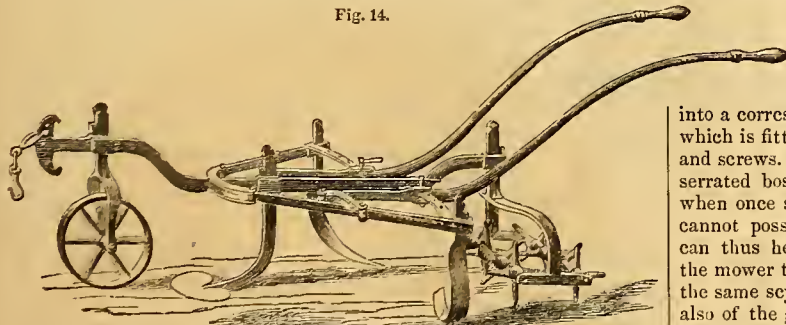

Fig. 13 explains the arrangement much clearer than our description. With this contrivance the ploughman has only to turn his adjusting handle back or forward, as the case may be, to traverse the nut along its screw, and thus widen or narrow the drilling path.

The "wrought-iron skim or paring ploughs," of Messrs. E. Hill and Co., of Brierley Hill Iron Works, Stafford, are powerful, well-made

Fig. 14.



implements, capable of working from $1\frac{1}{2}$ to 8 inches deep, over three or four acres a-day, with a pair of horses. The front portion, through

which the traction passes, is jointed, and so fitted to the after-part, carrying the knives, that on the attendant throwing his weight upon the stilts or handles; the latter turn on the hind pair of wheels as a centre, and lift the knives clear up, for turning or otherwise. In their "expanding horse-hoe for turnips," a contrivance is added for enabling the workman to alter the width of the knives without stopping. This may be effected instantaneously, without the adjustment of any screws or pins, by the mere drawing the handles apart, or bringing them closer together, the knives being set upon the front ends of the handle-levers themselves. Fig. 14 exhibits the hoe complete, and shows how perfect is the command which the operator possesses over the cutting details. By the new expansion movement, he can avoid any sudden irregularity in the ridge or drill, or in the horse track, as readily as if he were hand-hoeing. A small Norwegian harrow is fitted behind, for throwing out the weeds removed by the hoe. The continuous wrought-iron fencing, shown by this firm, allows of any point being taken away in five-yard lengths, and put in again, without disturbing the rest. The top bar of this fence is of $\frac{3}{8}$ th round iron, and it is connected to each side of the junction standard by a double ferrule on the standard, through each side of which, and the corresponding end of the rail-bar, a small key is passed, to form the connection; the lower bars, of $1 \times \frac{1}{4}$ inch flat iron, set edge upwards, the lengths being connected at the junction standards by overlapping joints—one end being straight, and the other cranked, to fit to it—whilst both are passed through the mortise in the standard without requiring any pins.

Fig. 15.

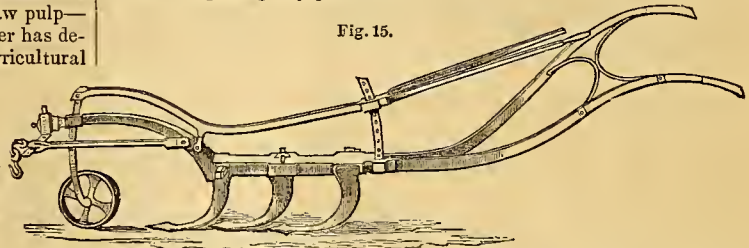

Messrs. J. Gray & Co., of Uddingstone, Glasgow, appear in the catalogue as extensive exhibitors, but their productions are not to be found in the building. Their "parallel lever subsoil pulveriser," fig. 15, however, did reach the Killarney Show of the Royal Irish Agricultural Society, and carried off the gold medal of that institution. It is a three-tined implement; these tines or pulverisers being set diagonally in the frame, with the arms of the first and last inserted in horizontal mortises in the frame-bar, so that their

path can be widened or narrowed at pleasure to the required breadth of furrow. The sketch shows how simply this is done: the central tine is mortised directly through the frame-bar, whilst the other two have each a bent arm passed through the bar from opposite sides, for lateral adjustment.

The "double-action, self-adjusting scythe," of Mr. Boyd of Lower Thames Street, London, claims some notice as an efficient improvement upon the old implement. It is delineated as folded up in fig. 16. Instead of being fastened at a determined angle like the common scythe, the blade is adjustable upon its handle, by a

Fig. 16.



very simple modification of a friction joint. The friction joint is provided with a serrated boss at each end of the parts, A and B. The end of the part, A, fits

into a corresponding serrated piece on a shaft, which is fitted on the end of the handle by nuts and screws. The heel of the blade has also a serrated boss, into which the end, B, fits; and when once screwed together, the several parts cannot possibly get disarranged. The blade can thus be easily set at any angle, enabling the mower to cut either field or lawn grass with the same scythe, whilst this adjustment allows also of the grass being cut at from one to six inches from the roots, either with an inclined or upright position of the body. The facility of closing up like a knife is a great advantage, as concerns portability.

GIRARD'S WATER-PRESSURE RAILWAY.

A novel system of railway propulsion—wherein direct fluid-pressure is employed as the actuating agent—has just been submitted to the world by M. L. D. Girard, a civil engineer of Paris. The propelling power is derived from a continuous water-pipe laid along the line, and charged with water under either a head or artificial pressure. This fluid-main is laid down in the central space of the line, between the two pairs of

Fig. 1.

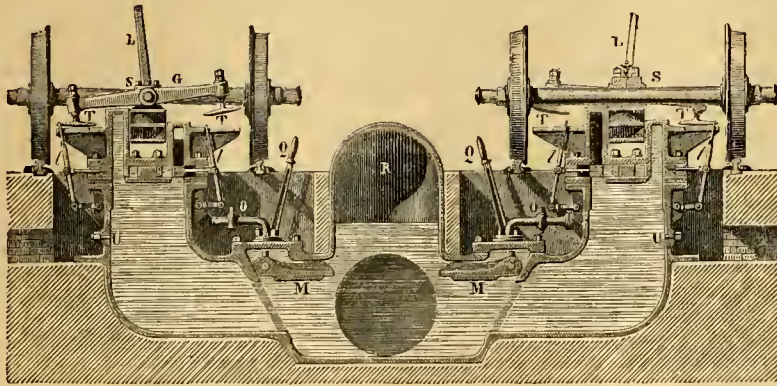

rails, and at intervals, along the line, it communicates with the motive apparatus, which simply consists of a series of apertures at which the water escapes, a particular direction being given to it by appropriate channels. These water-jets act upon a series of curved buckets, similar to those of a water-wheel, but arranged in a straight line under the carriage, and receiving the water at the sides.

Our engravings will render the details of the apparatus more intelligible, fig. 1 being a vertical section, and fig. 2 a plan of the arrangement. Water is conveyed under pressure through the main, A, extending along the entire length of the railway, and is made to act upon a

Fig. 2.

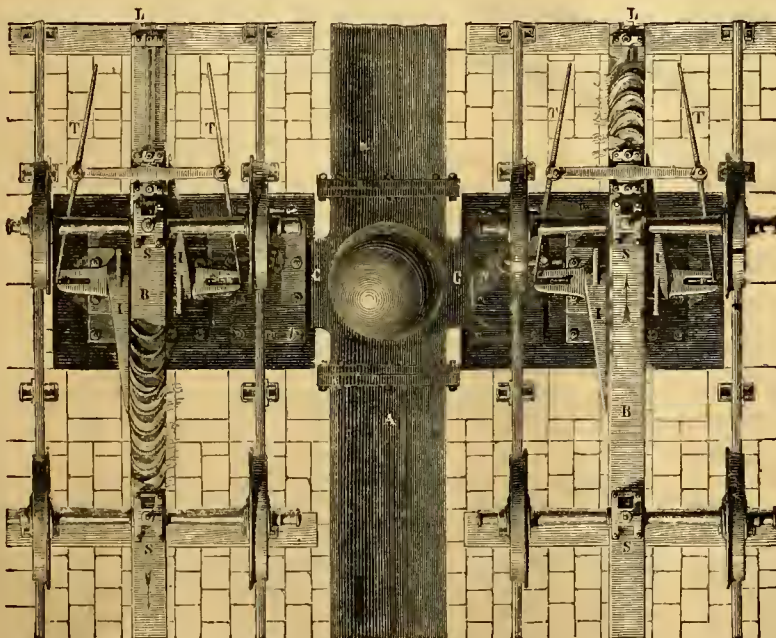

framework, B, carried longitudinally in the centre of the carriage, below the axles, to which it may be suspended by loose brackets, S. A series of cells are formed in this propeller frame, similar to the buckets of a water-wheel, and the motion is produced in precisely the same manner as in that prime mover, except that the motion of the buckets is rectilinear, instead of circular. At intervals along the line, side branches, C, C, are fitted to the water-main, communicating on each side with the discharge

ducts, T, T, fitted with appropriate valves, worked by levers, L, carried in brackets upon the discharge apparatus. These valves are worked by a system of levers, travelling with and upon the carriage. The conductor, or train-driver, actuates the whole, by means of the lever, L, upon the end of a horizontal shaft, the other extremity of which carries a duplex lever, G, to either extremity of which are attached the rods, T. Before proceeding further, we must mention that the propeller frame upon the carriage is divided horizontally into two compartments, in which the curved cells are set in reverse directions; the lower one, we shall say, being calculated for the advance, and the upper one for the retrogression of the carriage. The efflux ducts, T, are also in duplicate; that on one side of the propeller frame acting upon the lower compartment, and that on the other acting upon the upper one—the two, of course, lying in opposite directions, as seen in the plan, fig. 2. Returning to the valve arrangement, it is to be observed, that when the lever, G, is horizontal, the rods, T, will be clear of the levers, L, on both sides. If, however, the lever, G, is depressed to the left, as on the left-hand side of the figures, the rod, T, on that side will come in contact with the end of the lever, L, and open the corresponding discharge ducts, causing the carriage to be propelled in the direction of the arrow. The rod, T, is set in an inclined position, so as to act gradually upon the valve lever, L; and it is also fitted with a slight spring, to insure the perfect opening and shutting of the valve. After the passage of the carriage, the valves are shut by a similar mechanical arrangement, so that no water may be uselessly expended. The large valve, M, worked by the levers, Q, are for shutting off the communication of the main, A, with the branches, C, when repairs are required. The water that remains in the discharge apparatus may then be let out at the screw plugs, U, into the lateral ducts, which serve also to carry off the spent water from the propelling apparatus. When the repairs are completed, the cock, O, is opened, putting the two sides of the valve, M, in communication, so as to take the pressure off the latter before opening it. Air vessels, X, are provided to reduce the concussion produced by suddenly opening and shutting the discharge ducts.

M. Girard proposes to place the propelling apparatus at intervals of 300 feet along the line, placing them closer together near stations and upon inclines, so as to give more command over the motions of the train at these places. In regulating the speed of the trains, the conductor will work the lever, L, so as to open the ducts, or to pass without opening them; or, again, he can open the ducts upon the retrograde side, so as to retard or stop the forward motion, or reverse it, as may be necessary. Many of our readers will be reminded, by the perusal of this article, of the now forgotten scheme of a "hydraulic railway" by Mr. Shuttleworth.

SAGER'S STEAM-SHIP PROPELLER.

(Illustrated by Plate 136.)

The new propeller—of which we present seven detailed views in Plate 136—is the invention of Mr. W. Sager, of Seacombe, near Liverpool.

Fig. 1 is a side view of a steamer fitted with four sets of the propelling floats, involving four paddles each; that is, eight separate floats on each side of the ship. Fig. 2 is a plan of the ship, showing the actuating engines as geared with, and driving the whole sixteen floats. The detail, fig. 3, represents a single float, with its immediate actuating apparatus attached, as about to dip into the water in its propelling action. Fig. 4 is a corresponding detailed view, showing the float at its bottom-stroke, or in full perpendicular action upon the water. Fig. 5 represents the float as it appears during its withdrawal from the water for a fresh stroke. Fig. 6 is a fourth position, the float being on its upper centre, as it appears in passing clear through the air from the position, fig. 5, to give its succeeding impulsive stroke; and fig. 7 is a front elevation of the float, with its propelling details, as fitted to the ship's side, a part of the vessel being shown in transverse section.

The propelling power is primarily obtained from a pair of reversed horizontal steam-cylinders, A, supplied with steam from a boiler, B, set between the two cylinders. The piston-rods of these cylinders work in reverse directions, and they are connected directly to cranks on the pair

Fig. 3.

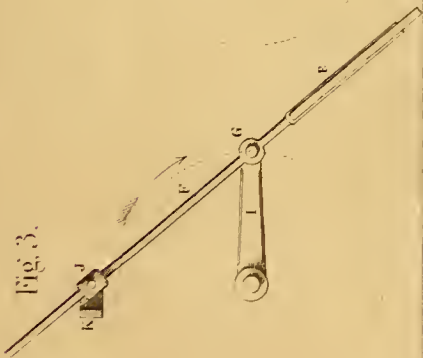

Fig. 4.

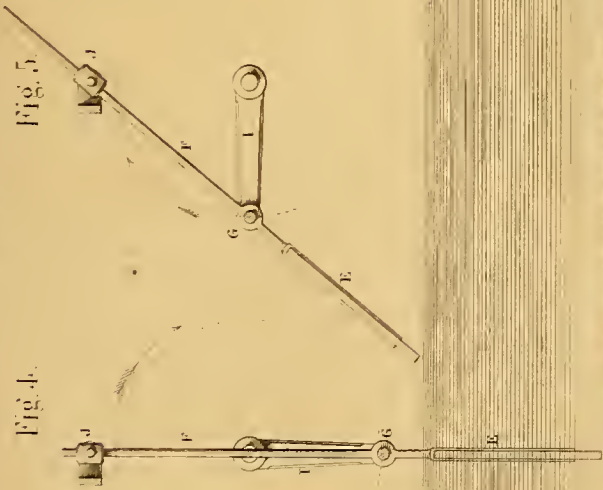

Fig. 5.

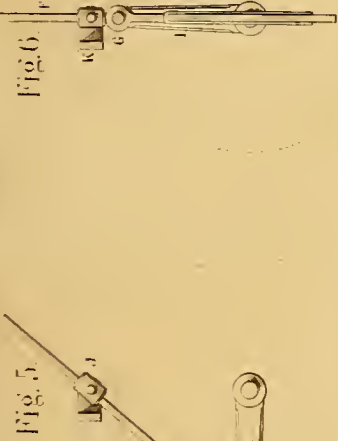

Fig. 6.



Fig. 7.

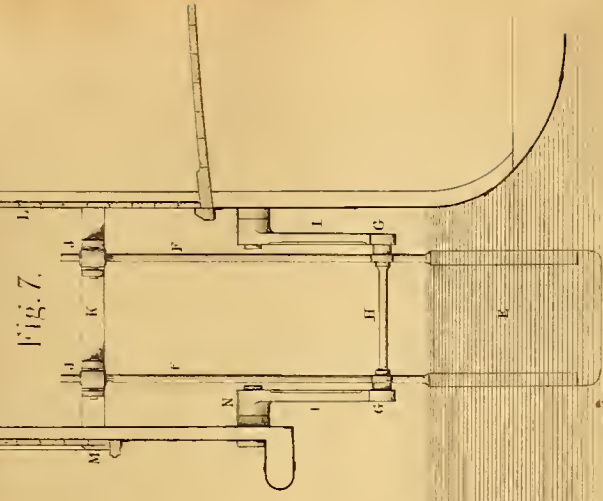

Fig. 1.

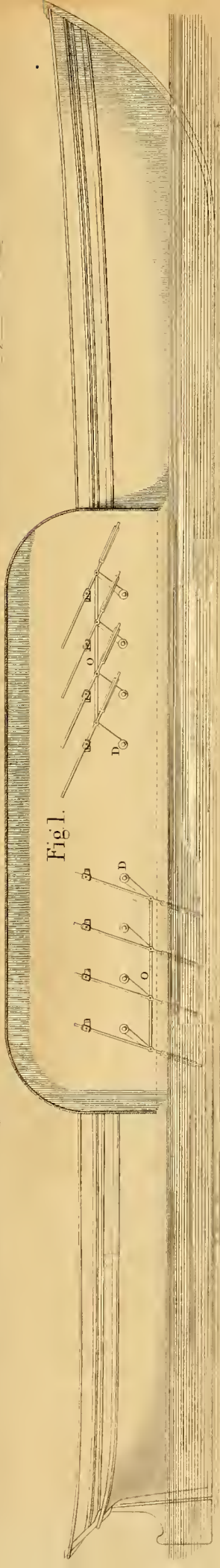
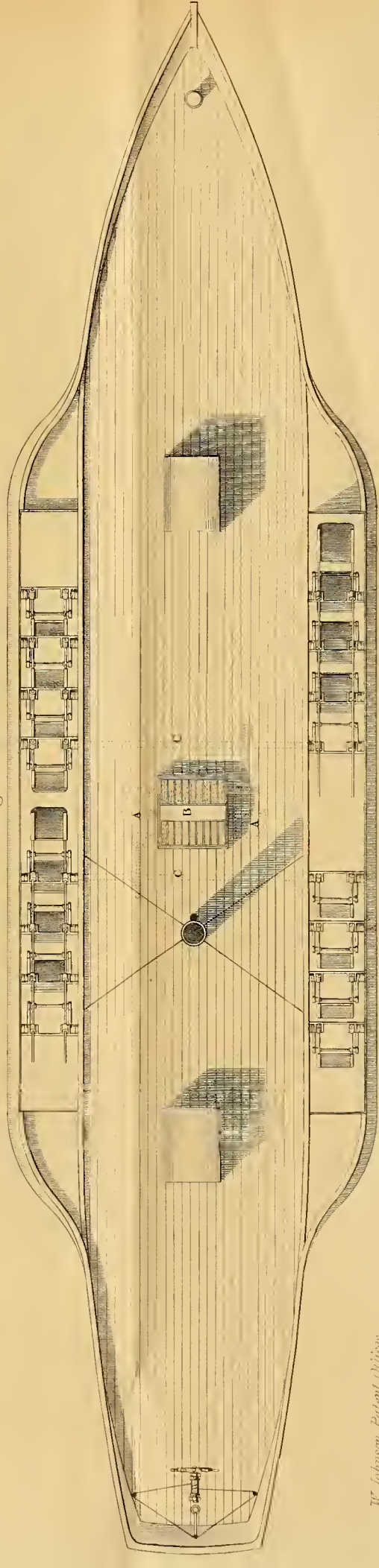

Fig. 2.



of parallel shafts, c, passing right across the ship. These two crankshafts work the whole of the floats, by passing through the sides of the vessel at d, and being thence connected to the two central floats of the range on each side. The four floats, thus driven by direct connection, are coupled to the remaining twelve by links and studs, so as to give the entire set a simultaneous propelling action. Each paddle, or float, e, is securely clamped to the lower forked ends of a pair of parallel guide-rods, f, which rods are formed with joint-eyes, g, for connection with the long intermediate crank-pin, h, connecting the two cranks, i. The upper ends of the guide-rods, f, work through guide-sockets or collars, j, arranged to swivel or work on stud-bearings, carried by the transverse fixed rail, k, projecting across, between the exterior, l, of the vessel, and the interior of the propeller wing, or cover case, m. The inside crank of each of the first-motion floats is keyed on the external projecting end, n, of the actuating shaft, whilst the corresponding external crank has its boss bored to turn freely upon a stud-pin, o, in the interior of the paddle-box.

It is now evident, that if the driving crank revolves in the direction of the arrow, the float—partaking of a movement made up from the compulsory circular traverse of the eyes, g, in the guides, f, combined with the restraining action of the swivel collars, j—is made to dip obliquely into the water, as at fig. 3. This is the commencement of the action. The onward revolution of the crank then causes the float to press back upon the water, as in fig. 4, rise up from the water in an oblique direction, as in fig. 5, and finally pass forward again above the water, as in fig. 6. Thus the float enters and leaves the water obliquely, opposing no undue resistance in going in, giving its full vertical effect when fairly immersed, and emerging again without any backwater.

When several floats are coupled together in the manner we have shown, the connections are the same throughout, the action of the impelling shaft being conveyed in each case, throughout the range of movements, by the parallel links, o. As in figs. 1 and 2, the two sets of floats on each side of the vessel are so set in relation to each other, that whilst one set is at its full propelling stroke, the other is inert, so as to equalize the result.

The inventor points out the fact, that this propeller possesses a peculiar facility for "unshipping," as all the floats may easily be turned round and set fast, clear of the water, when the vessel is to sail under canvas only. He also suggests the application of this plan of propulsion to small craft, employing manual labour in this way, instead of using a bank of oars.

THE NEW PATENT LAW.

The following "Act to amend certain Provisions of the Patent Law Amendment Act, 1852, in respect of the Transmission of certified Copies of Letters Patent and Specifications to certain Offices in Edinburgh and Dublin, and otherwise to amend the said Act," received the Royal assent on the 20th of August, 1853:—

Whereas it is expedient to amend certain provisions of the Patent Law Amendment Act, 1852, in respect of the transmission of certified copies of letters patent and specifications to certain offices in Edinburgh and Dublin, and otherwise to amend the said act: Be it therefore enacted by the Queen's most excellent Majesty, by and with the advice and consent of the Lords spiritual and temporal, and Commons, in this present Parliament assembled, and by the authority of the same, as follows:

I. Section thirty-three of the said Act, and such part of section twenty-eight of the said Act, as directs that in case reference is made to drawings in any specification deposited or filed under the said Act, an extra copy of such drawings should be left with such specification, shall be repealed.

II. The commissioners shall cause true copies of all provisional specifications left at the office of the commissioners to be open to the inspection of the public, at such times, after the date of the record thereof respectively, as the commissioners shall by their order from time to time direct.

III. A true copy, under the hand of the patentee or applicant, or agent of the patentee or applicant, of every specification and of every complete specification, with the drawings accompanying the same, if any, shall be left at the office of the commissioners on filing such specification or complete specification.

IV. Printed or manuscript copies or extracts, certified and sealed with the seal of the commissioners, of letters patent, specifications, disclaimers, memoranda of alterations, and all other documents recorded and filed in the commissioners' office, or in the office of the Court of Chancery, appointed for the filing of specifications, shall be received in evidence in all proceedings relating to letters patent for inventions in all courts whatsoever within the United Kingdom of Great Britain and Ireland, the Channel Islands, and Isle of Man, and her Majesty's Colonies and Plantations abroad, without further proof or production of the originals.

V. Certified printed copies, under the seal of the commissioners, of all specifications and complete specifications, and fac-simile printed copies of the drawings accompanying the same, if any, disclaimers, and memoranda of alterations filed or hereafter to be filed under the said Patent Law Amendment Act, shall be trans-

mitted to the office of the director of Chancery in Scotland, and to the enrolment office of the Court of Chancery in Ireland, within twenty-one days after the filing thereof respectively, and the same shall be filed in the office of Chancery in Scotland and Ireland respectively, and certified copies or extracts from such documents shall be furnished to all persons requiring the same, on payment of such fees as the commissioners shall direct; and such copies or extracts shall be received in evidence in all courts in Scotland and in Ireland respectively, in all proceedings relating to letters patent for inventions, without further proof or production of the originals.

VI. Where letters patent have not been sealed during the continuance of the provisional protection on which the same is granted, provided the delay in such sealing has arisen from accident, and not from the neglect or wilful default of the applicant, it shall be lawful for the Lord Chancellor, if he shall think fit, to seal such letters patent at any time after the expiration of such provisional protection, whether such expiration has happened before or shall happen after the passing of this Act, and to date the sealing thereof as of any day before the expiration of such provisional protection, and also to extend the time for the filing of the specification thereon; and where the specification, in pursuance of the condition of any letters patent, has not been filed within the time limited by such letters patent, provided the delay in such filing has arisen from accident, and not from the neglect and wilful default of the patentee, it shall be lawful for the Lord Chancellor, if he shall think fit, to extend the time for the filing of such specification, whether the default in such filing has happened before or shall happen after the passing of this Act: Provided always, that, except in any case that may have arisen before the passing of this Act, it shall not be lawful for the Lord Chancellor to extend the time for the sealing of any letters patent, or for the filing of any specification, beyond the period of one month.

VII. And whereas doubts have arisen whether the provision of the Patent Law Amendment Act, 1852, for the making and sealing new letters patent for a further term, in pursuance of her Majesty's order in council, in the cases mentioned in section forty of the said Act, extends to the making and sealing of new letters patent, in the manner by such Act directed, where such new letters patent are granted by way of prolongation of the term of letters patent, issued before the commencement of the said Act: And whereas it is expedient that such new letters patent, granted by way of prolongation, shall be granted according to the provisions of the said Patent Law Amendment Act: Be it declared and enacted, that where her Majesty's order of council, for the sealing of new letters patent, shall have been made after the commencement of the said Act, the said provision of the said Act for making and sealing, in manner aforesaid, of new letters patent, shall extend, and shall, as from the commencement of the said Act, be deemed to have extended, to the making and sealing, in manner aforesaid, of new letters patent for a further term, as well where the original letters patent were made before, as where such original letters patent have been issued since the commencement of the said Act.

VIII. This Act, and the Patent Law Amendment Act, 1852, shall be construed together as one Act.

MESSRS. BEURET AND DERTELLE'S DOMESTIC STOVES.

This French invention comprehends a series of improvements as regards the several points of reduced cost of construction, increased capability of cooking effect, and economy of fuel. Our engravings represent, in fig. 1, a vertical longitudinal section; in fig. 2, a transverse vertical section; and in fig. 3, a horizontal section, of a stove of the new class.

The entire stove is formed of cast-iron plates, so shaped as to clasp

Fig. 1.

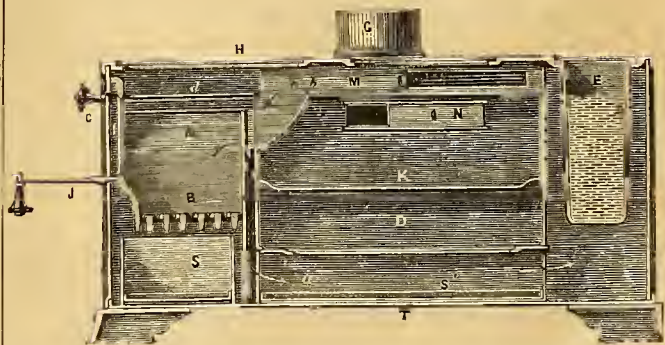

together, thereby requiring neither riveting nor screwing together. The fire-box, A, is at one end of the stove, and the fire-bars, B, are made separate, or in couples, so as to be removable separately. The flames and gases pass in the direction of the arrows, through the flues and various compartments of the stove, being divided into two currents, one of which takes a downward course, as at a, passing under and heating

the chamber, d. An open grating may be placed in the bottom of the grating here, so that the articles to be cooked may receive the direct action of the flames, as in broiling and frying; and this arrangement is claimed by the inventors as a peculiar novelty. The flames and gases then pass on to the chamber containing the boiler, v, entirely enveloping the latter, and finally reaching the smoke-box, r, and passing off up the chimney, e. The other current takes an upward direction, as at b, and the flames spread themselves through the space, l, and

Fig. 2.

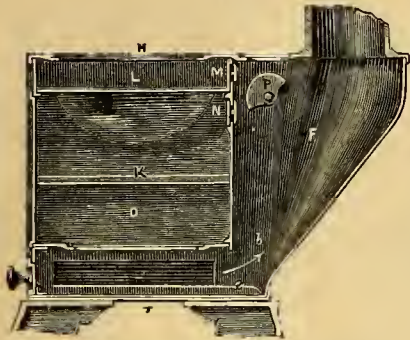

over the entire under surface of the top-plate, u, which is provided with apertures of various forms for pans, covers being placed over them on the removal of the pans. This current then unites itself in the boiler-chamber with the first one, or a more direct route to the chimney may be obtained by opening the damper, m. A second damper, n, is provided in the chamber, d, to carry off the vapours from the meat; or the diaphragm, k, being removed, it will allow the flames to draw directly through from below, when broiling or frying is the process in hand.

When required, the flames and smoke may pass directly through an aperture in the division plate, o, to the chimney. This aperture is provided with a valve, p, worked by means of the external button, c, and spindle, d.

At one side of the fire-box is a vertical grating, i, and a door, j, which opens down to a horizontal position, as a support for articles to be roasted at the grating.

Suitable adjustable inlets for air are provided both above and below

Fig. 3.

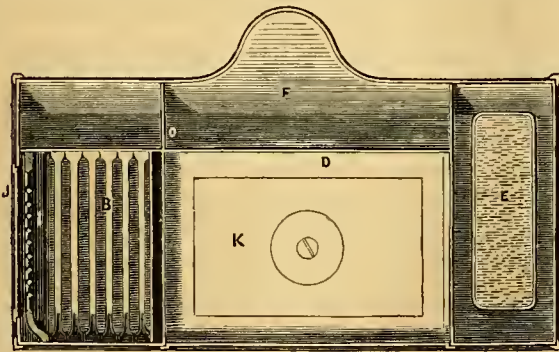

the bars, u, and the ashes are caught in the removeable pan, s, resting upon the bottom plate, v. A dripping-pan, s', is also constructed, to be placed under the chamber, d.

The entire arrangement is very simple, and appears well calculated to attain the desired object.

GLASSON'S IMPROVED OVAL TUBULAR BOILER.

(Illustrated by Plate 137.)

A peculiar arrangement of steam boiler, fitted with flue-tubes of oval or elliptical transverse section, has just been patented, and is now being introduced by Mr. Josiah Glasson, of the Soho Foundry, Birmingham. Our Plate 137 exhibits the invention under two separate modifications—one having vertical flue-tubes, with the boiler water circulating through them; whilst the other is a boiler of the ordinary kind, but fitted with the oval tubes instead of the usual cylindrical ones. Fig. 1, on the plate, is a vertical longitudinal section of the vertically-tubed boiler; fig. 2 is a corresponding vertical section at right angles to fig. 1, showing the three fire-places in end view; and fig. 3 is a horizontal section of the boiler. The tubes are arranged in boxes, or cells, and the end, top, bottom, and sides of each box are beveled inwards, to allow the box being tightly

wedged into a socket by bolts at the end, a. By merely unscrewing the bolts, the box may be withdrawn and repaired, or replaced by duplicates, at any time. In the second or horizontal tube arrangement, fig. 4 is a front sectional elevation, and fig. 5 is a vertical longitudinal section of the boiler, at right angles to fig. 4. Fig. 6 represents a few of the tubes in transverse section on a larger scale; and fig. 7 exhibits a similar group of flattened cylindrical tubes. In the elliptical tube arrangement, a clear space of $1\frac{1}{2}$ inch is left round the tubes, with a free passage of $\frac{3}{4}$ inch between the rows. Mr. Glasson claims an advantage of an increase of at least 25 per cent. of heating surface over the common cylindrical tube, whilst they are as easily fixed in the tube plates as the ordinary tube.

On a first examination of this boiler, a question naturally arises as to how boiler-makers are to obtain tubes of the new section; but we find that tube-makers are readily disposed to make them as cheaply as those of the old form. Another point for consideration is, the best mode of making the necessary holes in the tube-plates; but Mr. Glasson states that he effects this very simply, and that he can turn out a tube-plate with the oval boles quite as quickly as one with round ones. By increasing the circumference of the tube, in changing to the new form, the area is correspondingly diminished, involving a reduction in the tube's length. For instance, common tubes of 3 inches external diameter, or $2\frac{3}{4}$ inches internally, are made from 6 feet to 6 feet 6 inches long, the outer circumference being 9.42, and the area 5.93 inches; now the oval tube of 9.625 inches circumference has an area of only 4.5 inches, and the lengths being proportioned to the areas, the oval tube must only be 5 feet long, in comparison with the 6 feet 6 inches round tube. But it may be urged, that tubes have hitherto been made much too short—so much so, as to allow a great proportion of the heat to escape as waste into the chimney. Some proof of this is to be found in the fact, that $2\frac{1}{2}$ inch tubes are usually 5 feet 8 inches long, their area being no more than 3.97 inches, or really 0.58 inch less than the oval tube. But if the new tubes must be shortened, we thereby shorten the boiler, which, in very many cases, would add materially to the convenience of arrangement. The engineer has a shorter fire to stoke, less space is occupied in the ship, and a less weight of water is carried, whilst the heating surface is at least kept up to, if not in excess of, that obtained by the round tube.

MECHANIC'S LIBRARY.

- Algebra, Cassell's Elements of, post 8vo., 1s. 6d., sewed. Professor Wallace.
 Bacon's Essays, Universal Library, royal 8vo., 1s., sewed.
 Builder's Perpetual Guide, 8vo., 4s., cloth, gilt. W. Thorne.
 Chemistry no Mystery, foolscap 8vo., 3s. 6d., cloth. Dr. Scoffern.
 Foliage and Foreground Draining, Hand-book of, 12mo., 6s. Barnard.
 Science, Marvels of, 5th edition, illustrated, 7s. 6d., cloth. S. W. Fullom.
 Tidal Rivers, Conservation and Improvement of, 7s. 6d., cloth. Calver.
 Useful Arts, Cyclopædia of, Vol. I., royal 8vo., 21s. Tomlinson.

BARRANS' CUP-SURFACE BOILER.

The peculiar form of boiler, illustrated by the three annexed figures, is the invention of Mr. Joseph Barrans, of New Cross, London, who has designated the plan by the title, "Cup-surface," from the cup or cavernous form of portions of the heating surface. Fig. 1 is a longitudinal section of part of a locomotive engine boiler, showing the fire-box complete, with the fire-box end of the barrel or boiler cylinder, and the barrel tubes; fig. 2 is a transverse section; and fig. 3 is a sectional plan of the fire-box alone. The cups, a, are what may be called "thimble" pieces, let into the walls of the fire-box, with their solid convex ends projecting into the water-spaces, and intervening between the stay-bolts, c. The mouths, or reverse open ends of these cups, are riveted or screwed into the inside copper box, so as to present their cavities to the direct action of the fire; or, instead of being

Fig. 1.

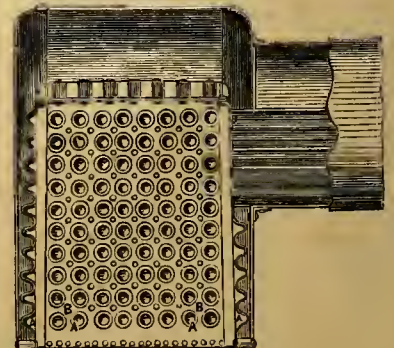

OVAL TUBE BOILER.

J. GLASSON, ENGINEER, SOHO FOUNDRY.

BIRMINGHAM.

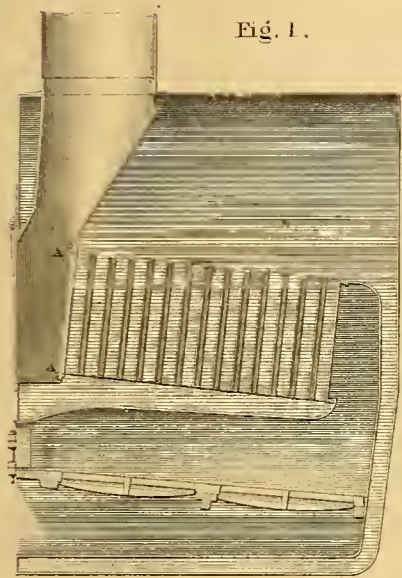

Fig. 1.

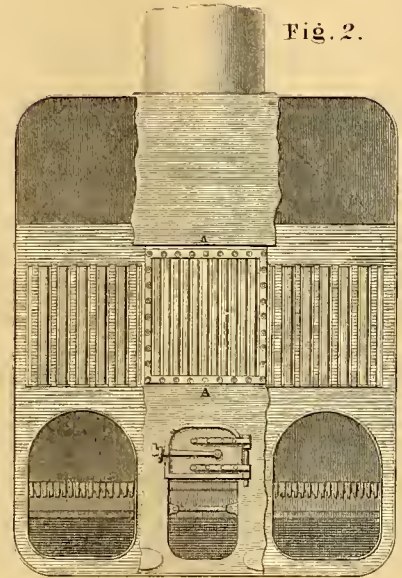

Fig. 2.

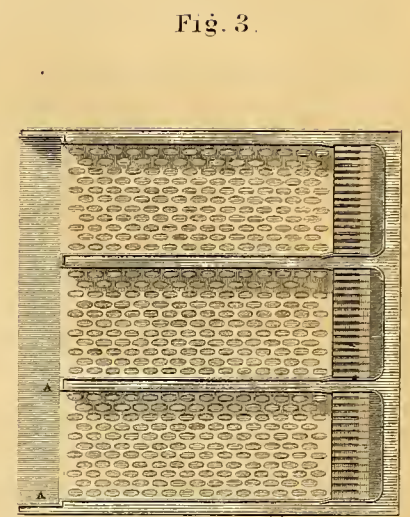

Fig. 3.

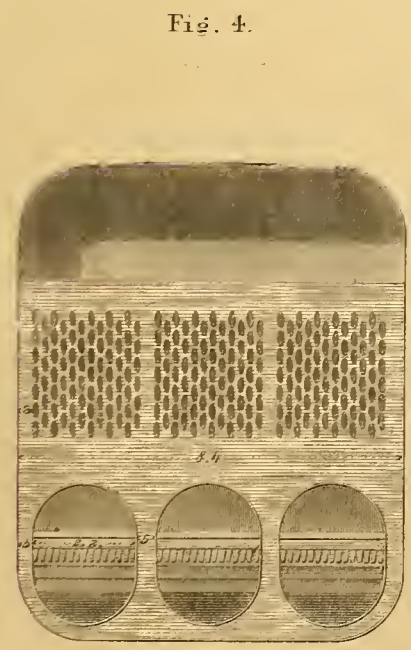

Fig. 4.

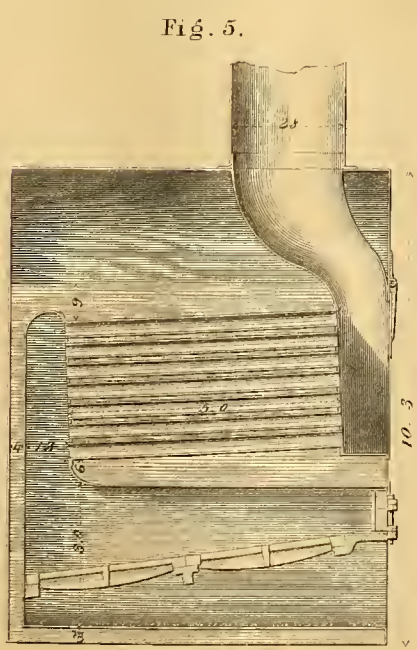

Fig. 5.

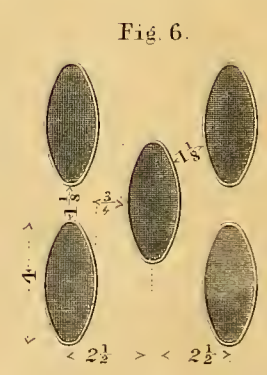

Fig. 6.

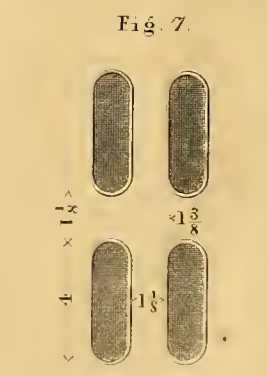

Fig. 7.

129 0 20 1 2 3 4 5 Scale 10 15 FEET

SCALE FOR FIGS 6 & 7. 2 INS - 1 FOOT.



thus made in separate pieces for subsequent attachment, the whole of the cups may be shaped out of the fire-box plate, whether the material is copper, as in the case of locomotives, or wrought-iron, as in stationary or marine boilers. In all other respects, the boiler is of the ordinary form and arrangement, with barrel flue-tubes, *v.*, passing from the fire-box tube plate to the smoke-box.

Fig. 2.

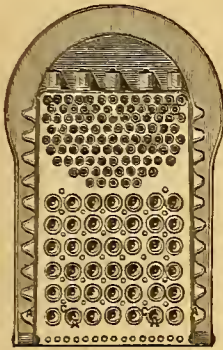

The inventor also makes another boiler on the same general principle, for stationary purposes, and fitted with a "double communicating smoke-burning fire-box." This duplex box consists of two short inside boxes, surrounded by one external case, and set a short distance asunder in the length of the box, the connection between the two being by a set of short tubes. Both of these inside boxes are cupped in the way we have described; and the barrel flue-tubes—for the entire boiler resembles the locomotive plan in this respect—pass from the usual tube plate in the second box, through the cylindrical boiler shell, as usual.

Fig. 3.



Of course, the first box only can contain fuel, the products of combustion passing from it, through the connecting tubes, to the secondary box, and thence, through the main barrel flue-tubes, to the smoke-box.

The obvious aim of Mr. Barrans has been the extension of the direct heating surface, without encumbering himself with an unwieldy fire-box, whilst he has also had in view the disposition of the parts in such manner, that the heat should be retained well up to its work. His success is indicated in the returns of some experiments now before us, showing that some 30 or 40 per cent. of heating area is gained by the new arrangement, and that about one-third more water per pound of coke is evaporated, than is usual in common boilers. A small boiler is in regular work at the Railway Foundry, New Cross, evaporating from 11 to 13 pounds of water per pound of coke.

SOCIETY FOR THE ENCOURAGEMENT OF NATIONAL INDUSTRY IN FRANCE.

This Society offers the following prizes, to be competed for in the years 1854, 1855, 1860, and 1865:—

CHEMICAL ARTS.

Subjects for prizes in the year 1854.

The manufacture of ammonia and ammoniacal salts for agricultural purposes.—Prize, 6,000 francs. (£240.)

The economical manufacture of fuel from turf for domestic and manufacturing purposes.—Prize, 3,000 francs. (£120.)

(Particulars and samples to be sent in prior to December 31, 1853. Adjudication of prizes to take place between June and December, 1854.)

Subjects for prizes in the year 1855.

The economical production of oxygen gas as a means of obtaining high temperatures for industrial purposes.—Prize, 6,000 francs. (£240.)

The discovery of a process for determining the capabilities of hydraulic cements or mortars in resisting the action of sea-water.—Prize, 2,000 francs. (£80.)

Essay on mortars already employed, or proposed to be employed, in marine constructions.—Prize, 2,000 francs. (£80.)

(Papers to be sent in prior to December 31, 1854. Adjudication of prizes to take place between June and December, 1855.)

Subject for a prize in the year 1865.

The discovery of a means of manufacturing, with artificial materials, and by an economical process, hydraulic mortars, capable of totally resisting the action of sea-water during at least ten years.—Prize, 10,000 francs. (£400.)

(Papers to be sent in prior to December 31, 1864. Adjudication to take place between June and December, 1865.)

No. 63.—Vol. VI.

ECONOMICAL ARTS.

Subjects for prizes in the year 1854.

A treatise giving an account of the various kinds of materials naturally or artificially incombustible.—Prize, 2,000 francs. (£80.)

New processes, new kinds of materials, or new manners of construction, capable of resisting fire.—Prize, 3,000 francs. (£120.)

(Papers to be sent in prior to December 31, 1853. Adjudication of prizes to take place between June and December, 1854.)

AGRICULTURE.

Subject for a prize in the year 1855.

The determination of the action and influence of water upon the growth of trees, and upon the formation and quality of the wood under different systems of irrigation, either with rain or spring water.—1st prize, 3,000 francs. (£120.) 2d prize, 2,000 francs. (£80.)

(Papers to be sent in prior to December 31, 1854. Adjudication to take place between June and December, 1855.)

Subject for a prize in the year 1860.

The determination of the influence of different modes of treatment in the growing of timber in a given soil.—1st prize, 3,000 francs. (£120.) 2d prize, 2,000 francs. (£80.)

(Papers to be sent in prior to December 31, 1859. Adjudication to take place between June and December, 1860.)

EXTRAORDINARY PRIZES.

1. Founded by Madame the Princess of Galitzin.

On the evils attending the universal consumption of the potato as an article of food.—Prize, 1,000 francs. (£40.)

(Papers to be sent in prior to December 31, 1853. Adjudication, June to December, 1854.)

2. Founded by M. the Marquis of Argensteuil (to be given every six years).

The most useful discovery as affecting the progress of French industry.—Prize, 12,000 francs. (£480.)

3. Founded by M. Bapst (to be given every ten years).

Rewards specially intended for poor mechanics.—1,500 francs. (£60.)

4. The gift of M. Christoffe (to be given each year). To three classes of poor inventors.—1,000 francs. (£40.)

5. Medals for foremen and workmen (to be given each year). Twenty-five bronze medals, each to be accompanied with books to the value of 50 francs—in all 1,500 francs. (£60.)

6. Rewards for the pupils of the industrial schools (to be given each year). Books, drawings, models, or instruments, for 15 individuals—in all 500 francs. (£20.)

RECENT PATENTS.

MANUFACTURE OF CAOUTCHOUC.

W. JOHNSON, *Civil Engineer, London and Glasgow.*
Patent dated February 24, 1853.

As in many other most valuable improvements in india-rubber manufacture, this important invention is a contribution from the United States, where it is now being most successfully worked out. Its object is the preparation of the raw juice or milk of the caoutchouc tree, in such manner that it shall remain in a fluid state, without deterioration; together with the after treatment of the fluid matter, for the production of a new article or raw material of manufacture. Shortly after the milk or juice is collected, it is strained, and has then added to it a quantity of the concentrated liquor of ammonia, or other ammoniacal matter, or any combination of nitrogen and carbon. The mixture is then well mixed, when it will remain in a white fluid state, capable of transportation and use, as a preserved material, if kept in air-tight receptacles. For the production of a new article of manufacture from this composition, it is run out on a suitable surface, and submitted to slow evaporation. This gradually solidifies the layer so poured out, and the mass becomes a new article of manufacture, very elastic and tough and transparent, and suitable for all the ordinary uses of caoutchouc, as well as many others not yet in existence.

The milk is collected by tapping the trees in the ordinary manner, the liquid so obtained being permitted to flow into suitable vessels of clay. When the liquid is collected, and before it has time to sour from atmospheric exposure—that is to say, within about three hours from the time that the liquid is produced—it is strained through a cloth into a clean tin or glass vessel. When this is done, concentrated liquor of ammonia, or

ammonia in any other form, or compounded to produce a like result, or any combination or compound of nitrogen and carbon, is added to the liquid or juice, in the proportion of about one fluid ounce of the liquor of ammonia, to every pound weight of the juice. In this mixture, the concentrated liquor of ammonia is preferred as the added ingredient. After this admixture, the composition is thoroughly mixed up, so as to be perfectly incorporated. The composition so produced is still a liquid under exposure to the atmosphere, and its colour remains equally as white as when drawn from the tree. In this state it may then be put up in air-tight cases or vessels for transportation, or after use, tin cases or glass bottles being used by preference for this purpose. When thus treated and packed, the mixture may be preserved for any reasonable length of time, and it may be conveyed to any part of the world, whilst it still retains its liquid state and pure white colour, suitable for manufacturing purposes, and in many respects far superior to the smoked or common india-rubber of commerce.

For the production of a new and original article of manufacture from this substance, it is poured or run on to plates of glass or polished metal, or glazed paper or other suitable receiving surface, of the desired size and form. In this condition it is subjected to slow atmospheric evaporation, either in the open air, or at the ordinary atmospheric temperature, or at a temperature of from 75 to 100 degrees of Fahrenheit. By this treatment, the liquid portion of the spread out mass is dissipated, leaving behind it a solid mass, very elastic and tough, and comparatively transparent or translucent, and possessing properties distinct from all other known substances.

PORTABLE HOUSES.

ROBERT WALKER, *Glasgow*.—*Patent dated Nov. 19, 1852.*

The houses built on the principle involved in this patent, are peculiarly suited for the dwellings and stores of emigrants. In building such

Fig. 1.



houses, a rectangular base frame is first laid down, and upon this frame, as a foundation, cast-iron pillars are bolted down at the four corners, and at other regular intervals—the spaces between such pillars being always so proportioned and arranged, that each four contiguous ones shall compre-

Fig. 2.



bend an equal-sided square area throughout the structure. Every pillar is grooved or slotted vertically down four opposite sides, so that suitable boards may be passed with their ends down such grooves, one above the other edgewise, to form the walls and partitions of the building. Such

boards are tongued and grooved like common flooring, the groove being always turned downwards, in order to prevent the lodging of rain therein. In this way, a cheap house is obtainable with little trouble—an order for such a house being simply for a certain number of pillars, and their corresponding number of flooring boards, each pillar being exactly the same, whilst each board is of the same length and cannot be transposed, variations only occurring at doors and windows; and, owing to the pillars having four grooves, the dimensions of the house may be extended to any amount, and cross partitions may be put in to subdivide the rooms. The window-frames are of cast-iron, grooved all round their outer edges, in order that the ends and edges of the contiguous boards may be inserted therein. The doorways are also formed with a similarly grooved frame, the two halves of the hinges being cast on one side of the frame, and the lock-staple on the other. The other halves of the hinges are of wrought-iron, and are fast to the door, these halves carrying the joint-pins for insertion into the halves on the frame. The roof is either of corrugated iron, angular or rounded, or it may be made of thin flooring boards, bent to the required arch, and screwed down at each end—the weather covering being simply asphalted felt in sheets, or layers of waterproofed paper or canvas. Various other coverings may also be adopted over the top of the boards or other support. Although cast-iron pillars are deemed preferable to timber ones, it is obvious that timber ones, similarly grooved, may be used as the supports for the boarding. The wooden walls, or the side boarding of houses of this class, have perfect freedom of expansion and contraction vertically. Fig. 1 is a front elevation of one of these buildings; and fig. 2 is a sectional plan, showing its internal divisions; fig. 3 is a horizontal section of one of the pillars detached; and fig. 4 is a side elevation of another arrangement of pillar and wall boarding. The rectangular timber frame, A, forms the base of the erection, carrying the four corner pillars, B, and the intermediate pillars, C, eleven pillars being required in this particular example. Each pillar is grooved longitudinally on all the four sides, as at D, to receive the wall boards, E, which are tongued and grooved to joint to each other. Boards so prepared are passed into the grooves of the pillars from the tops of the latter, before the roof is on, the board to form the base of the wall being first passed down, with its ends in the grooves of two neighbouring pillars. This board is passed down to the bottom, and it is followed by a succession of others, until the wall space is filled up to the eaves. And in order to render the insertion of the boarding of easy accomplishment, whether the roof or upper frame is on or off, the tops of the pillar grooves are left open laterally, to the breadth of a single board, so that the boards can be passed in from the side. The cast-iron window-frames, F, are grooved all round to receive the ends and edges of the boards in which the windows are placed; and each internal wooden frame, H, in which the glass is placed, is retained in position when closed up vertically by the back and front flanges, I, J, on the cast-iron holding frames. On each side of the wooden frame is a pivot, capable of oscillation in an eye on the iron frame, a button or fastener being fitted on to hold the window up against its frame bearings when closed; and, to add a little effect to the windows, each is surmounted by an outside cornice, X, of wood. The cast iron door frame, O, in the main front, or external wall, is similarly grooved on the top and two sides, to hold the ends of the boards, the two halves of the hinges being cast on the frame on one side, whilst the other side is cast with the lock-staple upon it. The corresponding halves of the hinges are of wrought-iron, and are screwed or otherwise attached to the wooden door, S; the door is also surmounted by a simple ornamental cornice, like the windows.

Fig. 3.



Fig. 4.



In the engravings, the main external walls have five windows in the aggregate. The entrance door, S, opens into a large dining or common room, T, from which two doors, U, V, on the left, open into two separate apartments, W, X. These apartments are formed on precisely the same principle as the main walls already described, and it is for the purpose of forming such minor divisions that the pillars are all cast with four opposite grooves, so that boarding may be placed to radiate on all the four sides of the pillars, if required; and by this means, houses of this kind can be remodelled at any time by transposing or adding partition walls.

When all the necessary boards are put in, a top frame, X, of timber is laid on the pillars, the finish at this part being produced by an orna-

mental strip, z. Upon the two parallel sides of this frame, x, are laid edge hoards, a, convex on their upper edges, to suit the convexity of the tongued and grooved hoarding, b, forming the roof. This roof consists simply of a set of boards bent to the required curve, and screwed or otherwise fastened down at their ends, c, and along the pieces, a, and down to cross joists, the finish at the extreme upper edges being by the ornamental boardings, e. Instead of arranging the pillars with narrow grooves, as described, wider ones, as at A, in fig. 4, may be used. In such case, plain hoards, b, are inserted in the grooves and passed down angularly—one resting upon the other, and forming a firm wall, nails or pins being passed transversely through the contiguous edges, to bind the hoards together laterally. This arrangement allows of the whole wall moving by expansion and contraction vertically, and thus prevents injury from splitting or tearing. When internal partitions are adopted, the pillars are cast with additional narrow grooves to receive their boarding. Such lining leaves a space between it and the outer main wall, so as to form a non-conducting air-space, preserving the house at an equable temperature, warmer in winter and cooler in summer, than when a single wall only is used.

INDIA-RUBBER SPRINGS.

W. C. FULLER and G. M. KNEVITT, *Bucklersbury, London.*—*Patent dated 6th October, 1852.*

Mr. Fuller, who is well known as a very early and successful inventor of caoutchouc and other springs, has in this instance applied himself to the introduction of india-rubber springs for common road carriages. Two plans are here elaborated. One is, that in which the elastic effect is obtained by the compressive power of the load upon a ring or series of rings of india-rubber, like those first applied by Mr. Fuller under his patent of 1845, for railway purposes; the other consists of the extension of a strap, or a combination of straps, of various thicknesses, interwoven in certain parts with canvas, and secured by metal plates, so as to form a spring for the suspension of the carriage body.

The chief difficulty to be overcome in applying india-rubber in this way, has been that of obtaining an efficient means of securing the wheels and axles in their position, allowing of a free vertical action in the spring itself, whilst sufficient strength is preserved for resisting the strain and concussion of travelling. This has been overcome in some arrangements, by passing iron stays under the axle, and fixing them at each end to the carriage body—a contrivance especially suited for the heavier class of vehicles. The india-rubber itself scarcely weighs one-tenth of a common steel spring, and, even with the additional ironwork, the new spring dispenses with from one-half to two-thirds of the weight hitherto necessary.

Fig. 1 is a side view of a cart or waggon spring of this class: A is part of the side framing; B is a stay-iron fixed by bolts at each end, and passing under the axle, C; at N are two upright bolts which pass through the framing, and are secured by nuts to the stay-iron, B, at their lower extremity; E is a plate of wrought or cast-iron which clips the axle or axle-head, and is firmly bolted thereto. This plate, of which a plan

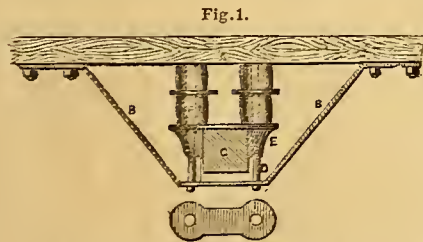

Fig. 1.

is shown beneath, has two parallel sockets to receive the upright bolts, N, so as to work freely upon them, and thereby keep the axle in its proper position, allowing a perpendicular motion to the body of the carriage. At F are the india-rubber rings, placed between the body and the axle-plate, E, and kept in their position by the bolts, N.

Fig. 2 is a similar view of another modification. At A is the side framing, as before; B is a front stay-iron, secured to

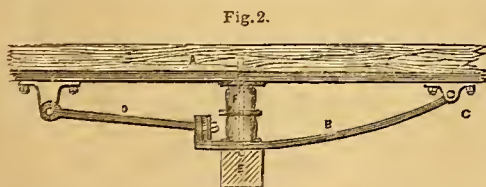

Fig. 2.

the stay-iron, B, is secured thereto by a nut and screw with a thin ring of india-rubber, which allows of the requisite motion upwards and

downwards. The spring is formed of a single or double ring of india-rubber, F. Where a double ring is used with this stay-iron, the separating plate should be fixed to the centre pin or bolt, which will then work upwards and downwards as the compression takes place, the object being to give greater freedom of motion than if the bolts were fixed, and to correct the slight deviation there would otherwise be from a perpendicular action.

Fig. 3 shows a spring with an elliptic stay-iron. A is the side-framing, as before; B, an elliptic stay-iron, fixed thereto by bolts at each end, and passing under the axle; at C are two jointed tie-rods, secured at each end by means of a nut and screw; at N are two small rings of india-rubber, which, by their elasticity, tighten the rods, and allow

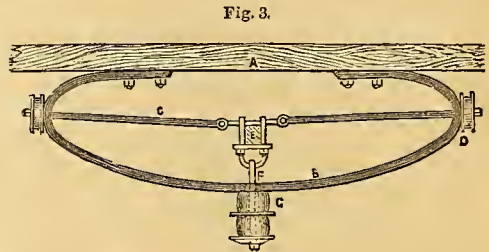

Fig. 3.

of a flexible motion upwards and downwards, and also to a slight extent laterally; E is the axle, which is bolted to the centre part of the tie-rods, C. The weight of the body is suspended to the axle, E, by means of the perpendicular bolt, F, which passes through the stay-iron and india-rubber rings, G G, terminating with a nut and screw.

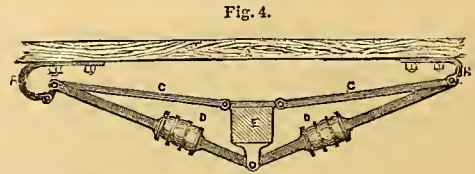

Fig. 4.

The situation of the rings, G G, may be sometimes varied with advantage—as, for instance, by placing them above the axle, and on each side

of it, using two lighter columns instead of one. It may also be advisable, in some cases, instead of the tie-rods, C, to use a strong leather

strap, of the whole length, which, by its flexibility, will supersede the necessity of joints, the tension being regulated, as before, by the compression of the india-rubber rings at each end.

In fig. 4, the side-frame, A, carries the two scroll irons, B, for holding the duplex levers, C, the elastic rings, N, being here set beneath the axle, E, and acted on by the lever-pressure from above.

In fig. 5, the same letters are used as in the last example; the spring-rings, N, are set on a bar beneath the ends of the acting levers, C.

Fig. 6 is an elastic shackle, so contrived, that the elastic ring serves as a substitute for the cross-springs of the carriage. A is the eye of the ordinary steel spring, as seen from behind; the shackle, C, being suspended from this eye, and carrying a round plate for the elastic ring, E. A bolt passes through the centre, to connect the ring, E, with the bottom eye, B, of the span iron, N.

Fig. 7 is a similar arrangement, where the india-rubber rings, E, serve as a substitute for the cross spring.

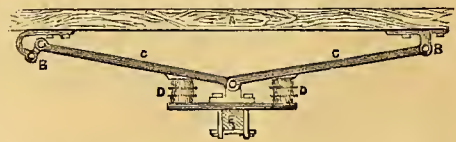

Fig. 5.

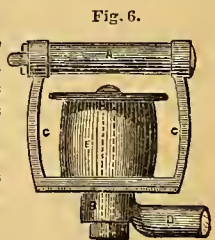

Fig. 6.

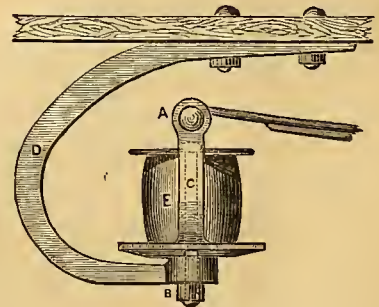

Fig. 7.

FIGURED FABRICS.

J. R. COCHRANE, *Manufacturer, Glasgow*.—*Patent dated February 22, 1853*.

The simple modification of manufacturing routine, introduced by Mr. Cochrane under this patent, promises to bear most importantly upon the economics of the "lappet" fabric manufacture, or figured goods, wherein the device is formed by laying the "whip," or pattern threads, upon the surface, and binding them down with weft threads. Such yarn or figure threads have hitherto been always beamed on rolls previous to weaving, the rolls being attached to the loom, and the yarn taken therefrom as required in the weaving action. But in this arrangement the cops of "whip" yarn are taken directly to the loom, and arranged in creels or suitable holding frames, and the yarn is thus unwound directly from the cops as the weaving proceeds. Thus the usual intervening processes which the whip undergoes, between the spinning and weaving, are dispensed with, and whilst the intrinsic cost of the process is lessened, the production of waste is also reduced. Or, by another mode, the hobbins of yarn, as filled from the cops in the ordinary manner, are taken to the loom, and held there in a suitable frame instead of the cops; and in both cases, whether the cops or hobbins are applied in this way, each line or frame of threads is passed round a paced roller, so as to give an equal uniform tension to all the threads during the weaving action, or the pacing may be effected under various other modifications. The tension roller may be paced or furnished with a friction apparatus by any of the ordinary modes.

Fig. 1 is a portion of a longitudinal elevation of the cop-holder at the back of the lappet loom, and fig. 2 is a corresponding end view or transverse section. The creel is composed of four standards, A, arranged with suitable base pieces, B, and bound together by transverse pieces, C, and top metal bars, D, whilst near the base is a perforated board, E, for holding the cops. This holder, E, is notched out at its four corners, so that it may be slipped into or removed from the retaining standards at pleasure. In commencing to work with this apparatus, the board, E, is taken out, for the convenience of arranging the cops therein in due order, as delineated in the drawings. The filled frame is then reinserted, and the loose longitudinal bar, F, is placed with its ends in the holding staples, G. Immediately over the range of cops are three guide-pin bars, H, resting by their ends upon the cross pieces, C, the guide pins or studs being set to project off from the bars in a horizontal direction. These bars are covered over with a layer of rough cloth, or other frictional material, and each thread of the yarn, as wound off from the individual cops, is

Fig. 1.

Fig. 2.

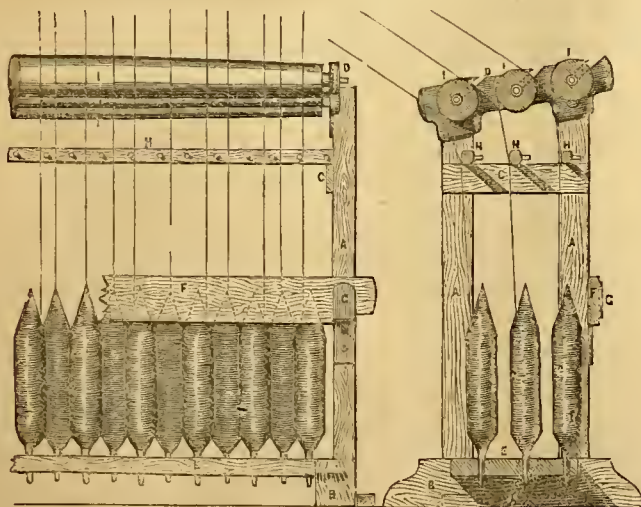

passed round its corresponding bar, and between the guide pins, directly over the cop in each case. Thence the thread passes round a corresponding overhead guide roller, I, three of which are set in an inclined row, with their end spindles turning in notched bearings in the plates, D; and after this second frictional turn, the thread proceeds direct to the weaving action of the loom, where it is interwoven, to form the intended device, in the usual manner. The rollers, I, are not plain cylinders, but are "barrelled," or tapered from the centre towards each end, for the purpose of assimilating the tension upon the threads throughout the whole line. For it is found in weaving with the ordinary plain cylinder,

that those lines of yarn near the centre of the piece are liable to become tighter, or to be strained to a higher degree, than those yarns which are nearer the selvages. But by tapering the roller in this way, the central threads pass over a larger circumference of roller than the selvage threads, and hence the tendency is to slacken the central threads and tighten the outside ones.

Fig. 3 is a longitudinal elevation of another modification of the apparatus, as fitted to weave the "whip" yarn from bobbins filled from the cops by the usual anterior winding process. The parts, A, are portions of the back part of of the common loom framing, with the main warp beam, B, fitted thereon in the usual way. Between the frame standards, a horizontal bar, C, is fitted in to carry two vertical pillar pieces, D, which are bolted on to the bar, C, to carry the hobbin creel frame, E. The hobbins are arranged on spindles in rows in the usual way, and each individual hobbin is paced, by a blade spring, F, screwed by one end to the creel, and pressing by its free end upon the thread wound upon the hobbin. From this series of hobbins, the threads pass, as at G, direct to the weaving action of the loom, as in the former example. Or, instead of this individual pacing, the lines of threads may be passed round rollers in the manner already described.

Fig. 3.

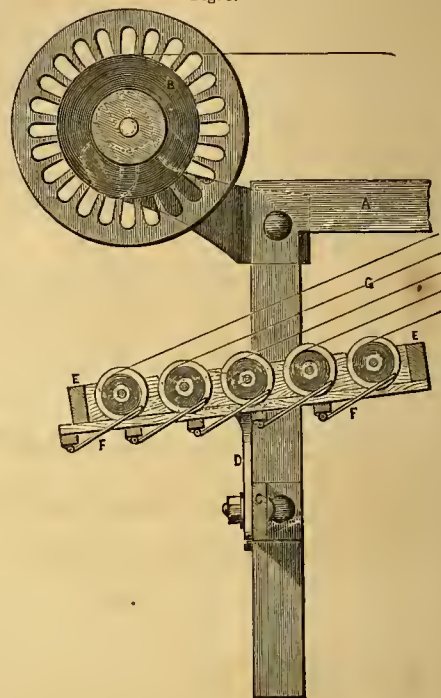

MANUFACTURE OF IRON FOR SHIP-BUILDING.

ROBERT M'GAVIN, *Glasgow*.—*Patent dated October 21, 1852*.

Mr. M'Gavin's ingenious invention has for its object the prevention of the adhesion of barnacles, and other animal matters or formations, to the bottoms and exposed surfaces of iron ships when afloat. He accomplishes this end by adding to, or mixing in, the iron, of which the ships are to be built, a small proportion of arsenic. This admixture may be effected either when the iron is in a state of fusion, or at any other suitable and convenient stage in the manufacture of the metal, such as in the puddling or blooming processes, when the metal is soft and plastic. The effect of such admixture with the iron is, that the resultant gradual feeble solution of the poisonous matter in the water destroys, or prevents, the adhesion of all barnacles and marine animal productions of every kind; and thus no hold is afforded for the foreign matters which ordinarily cling to the fundamental animal formations.

By adding the poisonous matter to the mass of metal during the process of the manufacture of such metal, the latter becomes thoroughly incorporated with the poisonous ingredient, so that the whole of the exposed iron of which a ship is built retains its poisonous qualities until actually worn out, instead of losing such qualities by surface wear. In practice, it has been found necessary to add as much of the ordinary white or yellow arsenic of commerce, as the iron will fairly receive without suffering any deterioration in its quality. This necessary amount of arsenic varies from two to five per cent. of the iron, accordingly as the quality of the latter varies. It is preferred to effect the admixture of the poisonous matter in the puddling furnace, the addition being made just before the metal begins to boil; or, instead of this routine, the poisonous matter may be placed between the metal blocks before the latter are heated for the rolling process. By pursuing this last plan, little or no loss of the arsenic ensues. The patentee also finds it necessary to sprinkle the outside plate, whilst it is red-hot, with a little

arsenic in addition, this sprinkling to be performed before completing the rolling—as, for example, before the last two entrances to the rollers. The poisoned plates are then well cleaned with strong acid, and are scrubbed with holystone, and immersed in a mixture of arsenic and spelter, tin, lead, or zinc. It is obvious that this system of treatment is applicable to the metal employed in various details concerned in naval construction.

Iron plates treated in this way have been tested by immersion in sea water, as well as by building them into the hulls of sea-going ships, with the most favourable results.

MOTIVE POWER.

JAMES ANDERSON, *Achnagie, Perthshire.—Patent dated Feb. 19, 1853.*

Mr. Anderson's invention relates to prime movers, or motive power apparatus, wherein air, gases, or vapours are used as the motive means. The air or other matter to be employed for obtaining power is primarily condensed or compressed to a considerable extent, and during this compression or condensation, a jet of cold water, or other suitable and convenient agent, is employed to cool or reduce the temperature of the air or body being compressed. Such treatment economises the mechanical power employed in the compression, by absorbing the evolved heat; and when the compression has been proceeded with to the required extent, heat is applied to the compressed body, so as to increase its elastic force,

and render it more fit for motive purposes, on its expansion in the act of actuating the engine or motive machine in which it is employed.

It is intended that such condensed, and subsequently heated and elasticated body, or medium, shall be worked in the ordinary manner, in any motive machine—as a common steam-engine, for example—the essential object of the invention being the economic obtainment of a convenient motive force or elastic body, for use in any machine, where an elastic medium is applicable as a prime mover.

SCREW-STOPPERED BOTTLES.

JOSEPH SCOTT, *Glasgow.—Patent dated Jan. 28, 1853.*

This is a contrivance for improving upon the old, ineffective, and very inconvenient system of closing bottles by corking. Mr. Scott cuts or moulds a screw-thread on the inner surface of the bottle neck, or opening, at the time of moulding the neck; and into this screwed neck he fits a correspondingly screwed stopper of wood, glass, earthenware, or other convenient material. This stopper is formed with a suitable head to facilitate adjustment, and its entering portion is serewed externally, to correspond with the internal screw in the neck—whilst beneath the expanded head is a groove, containing an annular jointing piece of some soft or elastic material, as gutta percha, india-rubber, canvas, or other substance. In this way, when the stopper is screwed into the bottle, this elastic surface bears down on the end surface of the neck, and pre-

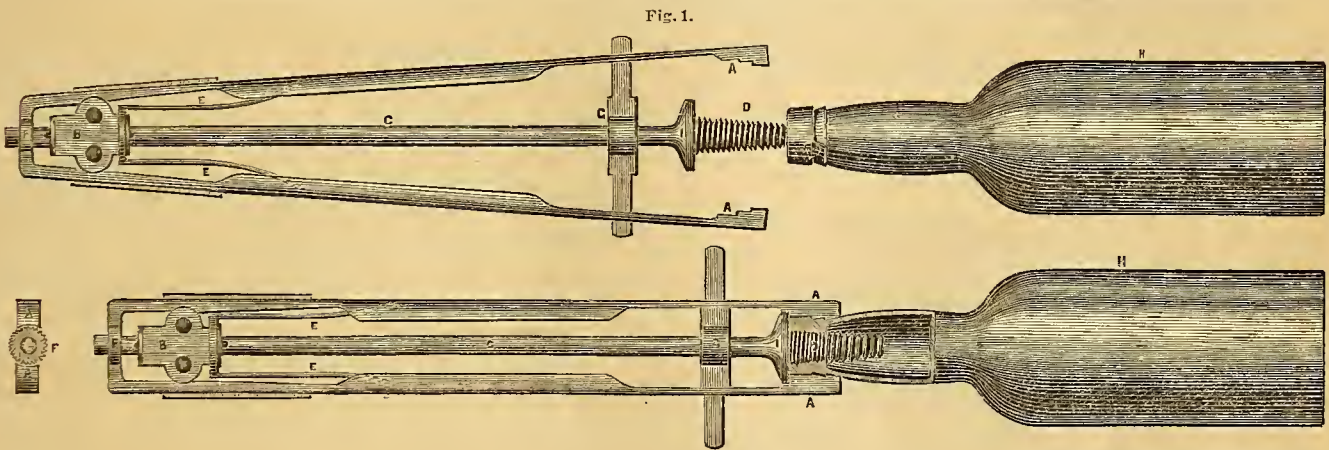

Fig. 1.

Fig. 3.

Fig. 2.

serves a tight junction. Such stoppers are easily screwed in and out, whilst they are always present for use, and will last as long as the bottle.

Fig. 1 represents a complete external elevation of a wine bottle, as in the act of being finished, with the shaping instrument, or shears, being just drawn out. Fig. 2 is a similar elevation, partly in section, with the shears in the act of forming the mouth, or bottle neck, internally and externally. Fig. 3 is an end view of a portion of the instrument, showing the engaging and disengaging catch for the screw spindle; and fig. 4 is a longitudinal section of the neck of the bottle, with the stopper in its place, on a larger scale. The shears only differ from those in use, and well known to the bottle manufacturer, as far as regards the central spindle for forming the interior of the mouth of the bottle. The two outside shaping pieces, A, are jointed to a socket piece, B, loose on the central rod, C, which shapes the interior of the mouth, and has a screw-thread cut upon it for that purpose at D, where it is slightly tapered. The shear arms are kept extended by springs, E, fixed to the piece, B, whilst they are prolonged beyond the joint, B, and are bent inwards to embrace a small ratchet wheel, F, fixed on the end of the screw spindle, C. The shears are further kept in position by a cross-piece, G, the ends of which work in slots in the shears, and these are prevented from being brought too close together by shoulders on the cross-piece. The bottle, H, having been blown in the usual way, and being separated from the punty, a small quantity of semifluid glass is taken upon the neck to form the mouth, the bottle being held by its bottom end. The workman then introduces the screw, D, into the neck, and when entered up to the shoulder, I, he closes the shears, A, and turns the bottle round

rapidly on his knee, the rotation forming the smooth outside of the mouth, whilst the pressure forces the glass into the thread of the screw, D, as represented in fig. 2. The closing of the shears, A, upon the bottle releases the small ratchet wheel, F, upon the end of the rod or spindle, C, so that this spindle revolves with the bottle, and the rotation, consequently, does not affect the formation of the screw upon the interior of the bottle neck. When the shears are allowed to open, their opposite shorter ends close upon the ratchet wheel, F, and the rod, C, with its screwed end, D, may then be unscrewed from the bottle's mouth, leaving a perfect screw-thread therein. The stopper, A, in these views, is formed with an external screw-thread, corresponding to the internal one in the mouth of the bottle, B; and beneath the expanded head is a ring, C, of india-rubber, gutta percha, or other elastic substance, let into an annular groove in the head, and forming a tight joint.

MANUFACTURE OF CANDLEWICKS.

N. CARD, *Manchester.—Patent dated January 12, 1853.*

Mr. Card's invention consists in first tightly doubling two or more single threads together into a strand, then doubling two or more of these strands together into a cord or thread, two being preferred, and afterwards twisting together as many of these said cords or threads as will produce a wick of the required thickness. By the use of this improvement he produces a much more even, firm, and compact candlewick, than by the ordinary method of manufacture. The wick thus produced is free from loose fibres, and will also preserve a more upright position whilst burning than one of the ordinary construction; and being more open than the common candlewick, it presents a series of channels for the passage of the tallow, or other inflammable matter, as well as air to the flame, during the process of combustion; thereby effecting a more per-

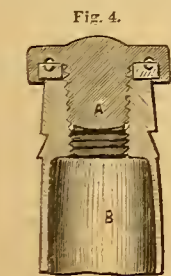

Fig. 4.

brought too close together by shoulders on the cross-piece. The bottle, H, having been blown in the usual way, and being separated from the punty, a small quantity of semifluid glass is taken upon the neck to form the mouth, the bottle being held by its bottom end. The workman then introduces the screw, D, into the neck, and when entered up to the shoulder, I, he closes the shears, A, and turns the bottle round

fect ignition, and also a considerable economy both in the wick and in the surrounding material, as the candle will give more light and yet burn much slower than one with a wick of the ordinary construction.

LUBRICATING MACHINERY.

J. H. JONNIXON, *London and Glasgow*.—*Patent dated January 26, 1853.*

This lubricator, the communicated invention of M. Rapeaud, of Paris, is more especially intended for railway axles, but it answers as well for shafts in general. In it, the oil is applied to the journal surface by a small roller or cylinder, revolving within the oil reservoir, and pressed against the journal by the combined action of the displaced oil, or the

Fig. 1.

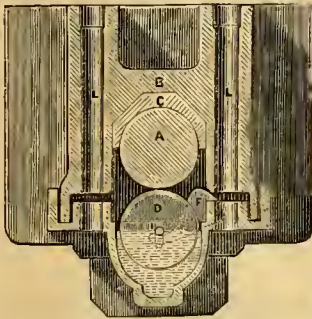
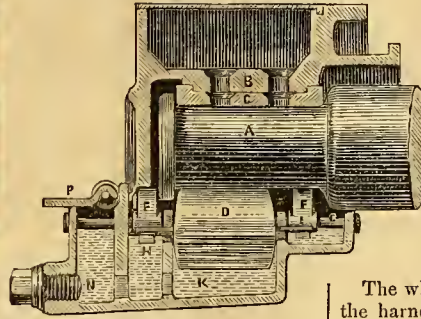

Fig. 2.



buoyant power of the floating cylinder, and the weight of a small counterpoise. Fig. 1 is a transverse section of a railway axle-box of this class, and fig. 2 is a corresponding longitudinal section, the axle being in its place.

At *a* is the journal of the axle to be lubricated; it is retained in its place in the axle-box, *n*, by the brass, *c*, fitted over its upper surface. The lower surface of the journal is kept in continual contact with the lubricating cylinder or roller, *d*, which is pressed against it by the combined power of the displaced oil in the reservoir, and the two weighted levers, *f*. These levers oscillate on the fixed centre, *g*, and abut at one of their extremities, *u*, beneath the ends of the axle, *i*, of the lubricating cylinder. The axle of the cylinder is guided and kept in position by the vertical slots in the partitions of the oil reservoir. In order that the lubricating cylinder—which may be made of wood, or of very thin sheet metal—may take up a sufficient quantity of oil to effect the proper lubrication of the journal, its outer circumference is surrounded by a piece of felt, or other soft and absorbent material. The oil reservoir is cast in one piece, and is composed of four compartments, *x*, which are connected by suitable openings in the partitions of the interior. It is connected to the axle-box by two bolts, which enter the bolt-holes, *l*, and thus retain it firmly against the under side of the axle-box—the latter projecting a short distance inside the reservoir, to prevent any accidental loss of oil over the edge when in motion. A channel is formed in the bottom of the reservoir, which slopes slightly towards the front of the axle, that the waste or impure oil, which sinks to the bottom, may be run off occasionally by the opening for that purpose at *x*. The oil is introduced into the reservoir through the lid, *r*, kept open or shut, as the case may be, by the blade-spring. The revolution of the journal transmits a corresponding rotatory movement to the cylinder, *d*, which thereby gives a constant supply of clean oil to the part to be lubricated, the waste oil sinking into the channel.

The patentee shows additional modifications of lubricators, but our engravings indicate the principle of the contrivance.

DUPLEX PATTERN FABRICS.

A. L. KNOX, *Glasgow*.—*Patent dated Nov. 5, 1852.*

By this system of manufacture, various kinds of ornamental fabrics—such as shawls, ladies' dresses, and what are technically known as "zebras"—may be woven with a totally distinct and perfect pattern on each side or surface of the piece. The invention may be carried into effect either by the Jacquard, or simple, or other pattern or figuring mounting; but when the Jacquard is used, the pattern cards are so punched with pattern holes, that each individual card may indicate or produce two distinct devices in the loom; and the result of the interweaving of the weft threads is, that a duplex pattern fabric is produced, showing two accurate figures, with the peculiarity that no two colours shall be opposite to each other, or occupy the same spaces on the two sides of the

piece. A similar effect may be produced by other mountings, as must be evident to the practical weaver; and instead of producing two figured surfaces, it is to be understood that one side may be woven as a plain coloured piece, whilst the other bears an ornamental figure in two or more colours, so that the wearer of the dress may have a choice either of wearing two patterns in the same dress, reversible at pleasure, or a plain coloured dress at one time, and a figured one at another. The essential feature of this invention then is, that by it the same weft thread produces two distinct figures or devices, one on each side of the fabric; that is, that the weft is caused to appear on either of the two sides of the piece, as required by the design, or it is retained, as it were, in the centre of the fabric's thickness, and kept out of view until wanted. In manu-

facturing fabrics of this class, the designer employs two or more designs, taking care that the colour used to produce the design on one side of the goods, is not arranged to be brought into play on the corresponding part of the other side. And in cutting the cards, or lashing the "simple" for the first side of the piece, the colours in the pattern are cut or lashed in the usual manner; but, in arranging the opposite side, these colours are left out at the parts corresponding with those where the same colours come in on the first side. For example, if red is the colour to be cut, all the red that appears in this first pattern is actually cut; but the red appearing on the second pattern is left, and all the space intervening is cut as red, thereby throwing the red, when not wanted to form the pattern on either side, between the two pattern surfaces.

The whole of the ties and connections of the harness, of whatever kind the harness may be, are arranged either as in the ordinary system of weaving figured goods, or by tying the harness for the warp used on each side; the peculiarity of the invention being the system adopted in primarily arranging the governing mechanism of the pattern or device, so that a distinct pattern may appear on each surface of the piece, the respective coloured threads being successively made to appear on the two opposite sides of the piece, or kept in the centre thereof, accordingly as the pattern on either side demands the presence or absence of the colours in question.

CARRIAGES AND WHEELS.

MARCUS DAVIS, *London*.—*Patent dated October 1, 1852.*

The improvements specified under this patent are now being introduced to the world through the agency of the "Silent Wheel Works," Gray's Inn Lane, a manufactory which, if rightly named, is a worthy novelty in the noisy metropolis. The construction of carriage wheels will be considered a question of no little importance, when it is known that contractors charge £6 per annum for keeping a pair of safety-cab wheels in repair, and £13 per annum for a pair of omnibus wheels. The spokes of Mr. Davis' wheels are of tubular metal, set in a wooden or iron nave, by means of a screw-thread formed upon the inner end of the spokes; or the metal for the nave may be cast round these screws, so as to combine the radially-disposed spokes into one mass; or, further, the nave ends of the spokes may be retained in position by a collar driven upon the nave, carrying sockets for the spokes. One of these tubular spokes serves as an oil reservoir, the oil being conveyed from the spoke, through a suitable hole in the nave and axle-box, to the rubbing surfaces, without the necessity of disengaging any of the parts. The outer rim, connecting the outer ends of the spokes, is also tubular, and this rim is embraced by the outer forked end of the spoke, a transverse pin being passed through to connect the parts. To render the wheels easy of motion and "silent," Mr. Davis encircles the rim with vulcanized india-rubber, in the form of a tube—the elastic tube being actually entered upon or over the rim, just like a glove and finger—or a number of elastic rings may be threaded upon the rim to produce the same result; soft materials, such as pasteboard, cloth, or canvas, being combined or not with the caoutchouc, as more or less deadening effect is to be given. By another modification, Mr. Davis uses flat bar-iron, curved to a circle, such circular piece of metal being attached to the spokes, so that the narrow edge works upon the road, the broad flat surface being parallel with the carriage side. Elastic materials are also combined in this plan of wheel, and, for light carriages, one rim only is used; but, for heavier ones, two are employed, wood or buffalo horn being inserted between the two, and, to strengthen large wheels, metal bars are passed across, from spoke to spoke, as lateral stays.

The seat for the fare, or the footholds, in the carriages known as "Davis' measuring and indicating cabs," the patentee contrives so as to rise when the fare leaves them, by means of springs below, or tensional india-rubber straps at the sides. When the fare sits down, the descent of the seat causes the indicator index to move to zero, by means of a cord or

other communication, at the same time putting the indicator wheelwork into gear. As it often occurs, also, that the fare leaves the vehicle for a short time, as when making a call, before finally discharging his cah, and it is, consequently, necessary that the index should not return to zero at each getting out, a projection is contrived on the door, in such a manner as, when open, to keep the seat or foothold depressed, so that, when the same fare is coming in again, the driver must allow the door to remain open, as, on shutting it, the seat or foothold would be released and spring up, and, on the re-entrance of a fare, the index would point to zero, as before.

The inventor next describes a contrivance for sheltering the driver in bad weather, consisting of a framework, to be set at any convenient height over him on such occasions, but ordinarily to be let down upon his seat, and sat over by him. It is further proposed to warm the vehicle by steam or hot air, by means of a small stove, placed near the driver's seat, or at any other convenient part.

Amongst other applications, Mr. Davis employs his wheels in the construction of fire-escape ladders, as represented in the annexed sketch. When the ladder is not tilted up against the wall, the wheels serve to convert it into a carriage, the two lower ends acting as shafts, to which a horse may be harnessed. The side pieces, or shafts of the ladder, are made tubular, and in pieces capable of forming any required length. To the top rundle a pulley is fitted, over which is passed a cord running down to the axle of the wheels, which acts as a winch when the ladder is placed against the wall; the other end of the cord is to be attached to a basket or carriage sliding up and down the ladder shafts, as on rails, an arrangement which affords a simple means of raising and lowering heavy articles to and from the upper stories of houses.

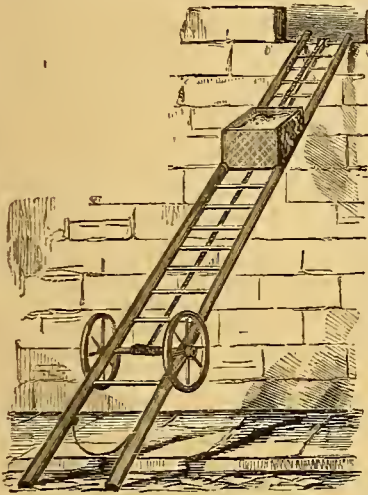

WINDOW FASTENINGS.

REV. MATTHEW ANDREW, *Hyde, Chester.*—Patent dated Jan. 21, 1853.

The sash-windows of dwelling-houses are fitted up by Mr. Andrew with a self-acting arrangement, so contrived, that, on the closing of the window, the separate sash portions are drawn into close contact with each other, preventing the occurrence of draught and the usual disagreeable shaking of the sashes. One sash is furnished with an inclined plane or projection, over which an inclined loop or staple falls upon the closing of the window, the action of these two inclined planes bringing the two sashes of the window into close contact. The staple is provided with a small spring-holt, which shoots into a catch or notch, formed upon or in the inclined projection—thus securing the two sashes until the holt is withdrawn by hand. Or, if preferred, the spring-holt may be attached to the inclined projection, with the catch or notch upon the staple. This is all the apparatus that is necessary, provided the sashes have no traverse sash-bars, or other similar transverse projection. Where the reverse is the case, it is necessary that the projecting staple and its appendages should be mounted upon slides, being so constructed and acted upon by a spring, as to slide back out of the way upon passing any of these sash-bars, but returning to its original position immediately after having passed them.

DRESSING AND FINISHING VELVET.

F. B. FRITH, *Salford.*—Patent dated November 12, 1852.

The apparatus described by Mr. Frith is intended for dressing, "machining," and finishing velvets, velveteens, cords, heaver-teens, and similar fabrics, by the agency of a spirally-grooved finishing roller, the revolution of which, in contact with the cloth, reduces the pile, nap, or other surface, to a uniform length, whilst it imparts to it a lustrous texture. The finishing and dressing is effected right and left across the piece, whilst the nap is finally laid the length or finished way of the

goods. Mr. Frith also applies a rapidly revolving roller, or "velure," covered with plush or velvet, for straightening the face of the goods; and a third head comprehends the adaptation of rollers and guide-rails for passing the goods over, whilst they are held at a proper state of tension by a weighted card-roller.

Fig. 1 is an end elevation of the dressing apparatus, and fig. 2 is a plan of the machine.

The framework, A, supports the first motion shaft, B, on which is the

Fig. 1.

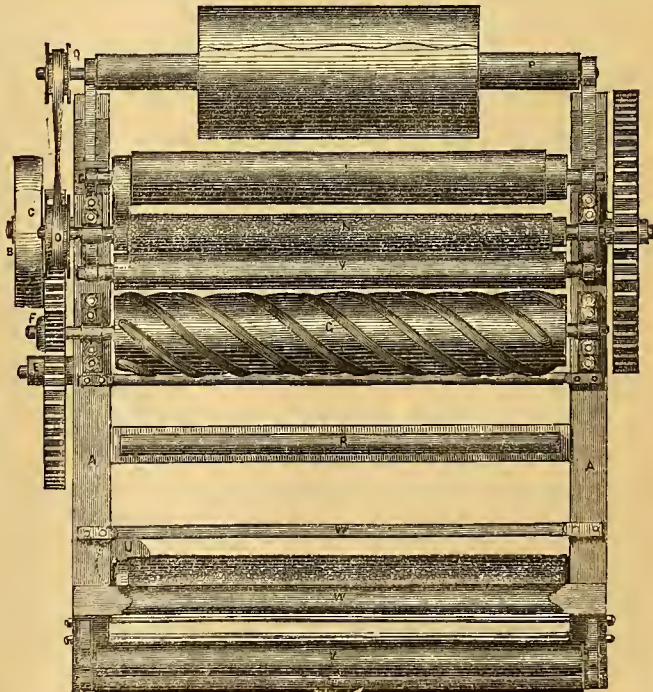
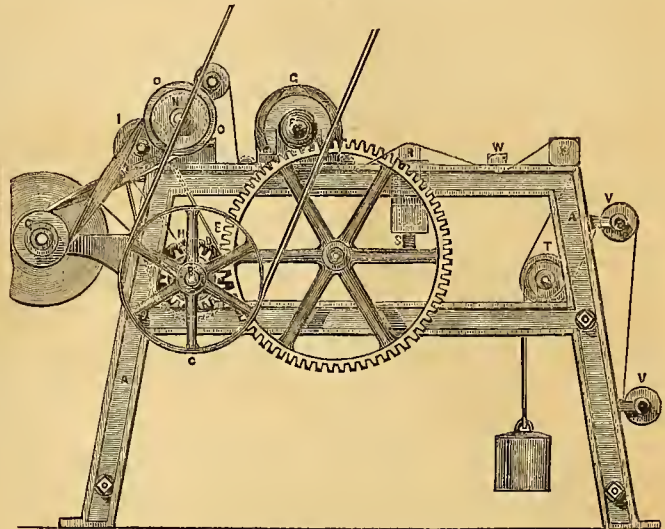

Fig. 2.

driving-pulley, C. This shaft carries a spur-pinion, D, driving a large wheel, E, which again is in gear with another pinion, F, keyed upon the shaft of the grooved roller, G. This roller may either be grooved spirally, as we have represented it, or it may have spiral ribs formed round it from end to end. It is covered with a layer of stone, glass, metal, or other material, of which the "pegs," employed in the common process of finishing by hand, are usually made. The main shaft also carries a pulley, H, for driving the "velure," or straightening roller, I; and it has, besides, a pinion in gear with the large wheel, M, on the spindle of the wire card-roller, N. On the other end of this roller, N, is fixed a pulley,

o, driving a roller, r—upon which the velvet, or other fabric, is wound—by means of a crossed strap passing round the pulley, q. A bar of bees-wax, n, is employed for waxing the pile of the fabric, and this may be raised as required by means of the screws, s. The roller, r—which is also covered with wire-card—has a strap, u, over one end of which a weight is suspended. This roller acts as a drag upon the cloth, and assists the guide-rails and rollers to keep the fabric at a proper state of tension, in contact with the grooved roller and the “velure.” At v are tension-rollers, and w are tension-rails. The fabric to be operated upon, after passing over and under two or more tension-rails detached from the machine, passes over and under the first two tension-rollers, v, then under the weighted card-roller, r, and over and under the first two tension-rails, w. The fabric then passes over the wax, n, and subsequently over the grooved roller, q, being kept in contact with about half the diameter of the latter by passing under two tension-rails. The fabric next passes over the third tension-roller, partly round the card-roller, and over the “velure,” or straightening roller, i. It finally passes under the main driving-shaft, and thence to the roller, r, upon which it is wound.

DRESS AND ORNAMENTAL FASTENINGS.

J. G. TAYLOR, Glasgow.—Patent dated February 25, 1853.

Mr. Taylor, who is the originator and patentee of a great variety of the best dress fastenings at present in use, has here increased the number, by adding some judicious improvements in brooch and other fastenings of a like character. Fig. 1 is a side view of a brooch, to which one of

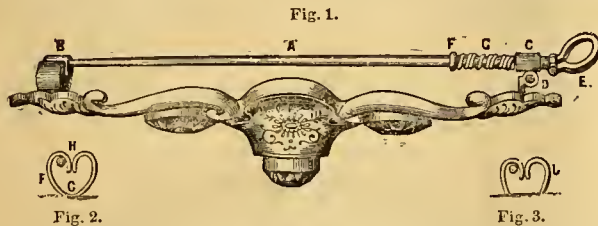

the new safety fastenings is attached. Here the usual retaining pin, A, has its point passed into a spring detent, B, formed as indicated in figs. 2 and 3, whilst the butt of the pin is entered through a guide socket, C, turning on a stud joint, D, a holding ring being attached at E. At F is a collar piece on the pin, and between this collar and the inside edge of the guide, C, is a helix or coil of wire, G, upon the pin as a spring. When the pin, A, is sprung into its catch, B, its point cannot of course be withdrawn therefrom laterally; whilst, to prevent longitudinal disengagement, the helical spring, G, always keeps the pin forward in its socket—and this continues until the ring, E, is drawn by hand to compress the spring, G.

Fig. 4.



The spring catch, B, for holding the pin's point, when entered into the dress for use, as shown in edge view in figs. 2 and 3, consists of either one or two flat pieces of metal, soldered to the setting at C, and having the ends bent over together at B, through which junction the pin's point is pressed, when it is to be engaged.

Fig. 4 is a side view of a holding pin, wherein the actual retaining pin, A, is bent round by an intermediate coil, G, from the opposite parallel piece of metal, C. This piece, C, forming the butt of the pin, has a flat

Fig. 5.



open catch, D, jointed to it at E; and when the point of the pin has been entered into the dress, it is sprung into the open end of the catch, B, which is capable of turning on its centre, E, to bring it into the plane of the two pieces of wire, A, C. This holds the pin secure; but when it is to be released, it is sprung back, and the catch, D, is then turned over upon its joint, so as to clear the pin's point.

Fig. 5 is an edge view of a brooch or ornament, in which the retaining pin, A, is hinged upon a stud joint, B, set transversely in the setting, so that the pin may swing round in a plane parallel with the back of the brooch, and thus its point can be entered laterally into a narrow opening in an elastic detent piece, C, fast on the setting. Disengagement cannot ensue in this instance, until forcible pressure is applied laterally to the point, to clear it through its narrow spring entrance in the catch, C. Various other plans, evincing a nearly equal amount of ingenuity, are also specified by Mr. Taylor. They will all be acceptable to the wearers of articles of the class to which they refer.

WORKING RAILWAYS.

G. STEWART, Enniskillen.—Patent dated Jan. 7, 1853.

Under this invention, Mr. Stewart arranges the rails of railways, and the wheels of the locomotive engines and carriages running thereon, so that such rolling stock may be taken up and down inclines, with greater safety and security than at present; whilst superior facilities are afforded for stopping the movement of such rolling vehicles at pleasure, and for enabling the locomotive to start with a train without serious risk of slipping on the rails. He accomplishes these several ends by indenting or forming teeth on the flanges of the engine or carriage wheels, for gearing with similar teeth or indentations, on racks either laid alongside the permanent rails, or forming part of such rails. Such teeth may be of various shapes and sizes, to suit the varying gradients of the line.

In the instance which he gives, the rails, which may be either of cast or wrought-iron, are formed for continuous bearings; and the toothed rack portion, which is on the inner side of each rail, is either rolled upon the rail, cast upon it, or formed and laid down separately. The teeth are angular, like ordinary ratchet teeth, so that they may work very freely, whilst great strength is secured in them. The teeth on the wheel are, of course, exactly similar, being cut or otherwise formed on the flange. With this system of working, the driving wheels have a firm hold upon the rails, so that the trains are under more perfect command than at present, as slipping can hardly occur in starting; whilst, when the brakes are put down for stopping, the frictional hold upon the wheels will give a superior retarding effect, by reason of the inclines of the working of the wheel teeth in those of the fixed rack teeth. And when the system is carried out throughout the entire train, the brakes will act equally well on each pair of wheels, as the same retarding power will be available in each wheel. It is to be understood, that the fixed teeth will only be required at certain determined places on the line—such as at stations where heavy loads have to be started on greasy surfaces, and at inclines, where the inclination tells practically upon the tractive adhesion; and by making the teeth of the peculiar form described, facilities are afforded for their entering into gear without jar, at the parts where the fixed teeth commence—the teeth at such parts being slightly lowered for the same purpose.

REGISTERED DESIGN.

VICTORIA COPPER POUCH, ADVERTISER, AND SAMPLE BAG.

Registered for MR. SAMUEL BRENNER, Carlisle.

This little contrivance affords a ready and convenient means of neatly folding up copper change and other small articles, whilst it answers as

Fig. 1.

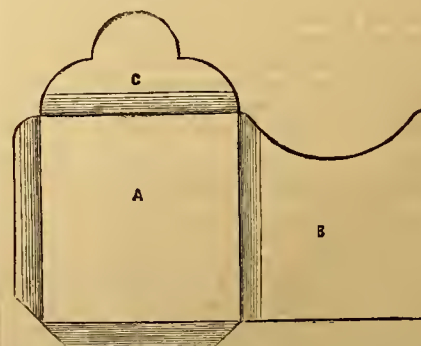
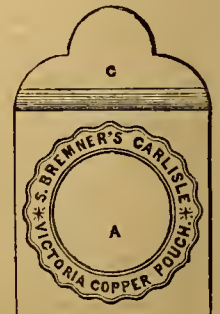

Fig. 2.



a means of advertising. Fig. 1 represents the paper blank, as cut out ready for folding up; and fig. 2 is a view of the folded pouch, with the

entrance-flap open. The paper is so cut that it forms the front, a, and back, b, in a single piece, which, being open at one end, and slightly pressed at the sides, gives a spring to the overlap, c, causing it to open freely for the insertion of its contents; and, when closed, it has a very neat appearance. As a copper pouch and advertiser, it is peculiarly adapted for the retail tradesman, as a ready receptacle for copper; and having a design in front, containing the name, profession, and address of the advertiser, it forms an effective advertisement. Being adhesive all round the inside of the overlap, from end to end—leaving a small outer-lap, which is non-adhesive, to facilitate opening—it answers as a sample bag. It is also suitable for paying wages on the large scale, as it facilitates the clerk's operations, and renders him less liable to error, more especially by having each pouch properly numbered, the receiver of the money having also a corresponding number.

REVIEWS OF NEW BOOKS.

THE PRINCIPLES AND PRACTICE OF LINEAR PERSPECTIVE DIVESTED OF ALL DIFFICULTY. By Richard Abbott, F.R.A.S. London: Longman, Brown, Green, and Longmans. 1853. Pp. 84. Woodcuts.

THE SCIENCE OF VISION, OR NATURAL PERSPECTIVE, &c., &c. By Arthur Parsey. London: Longman & Co. 1840. Pp. 142. Plates.

Much has been written about perspective—so much, indeed, and of so contradictory a nature—that the study of it has, in consequence, been classed amongst the difficulties of artistical accomplishments. A host of partial rules have been given, which, from their isolated character, and want of connection with any general principle, have rather confused than assisted the student, and most people are content to rely entirely upon their own ocular impressions, endeavouring to make the drawing on the paper look something like the object it is intended to represent in nature or art. And yet there should be no difficulty or uncertainty about it: it is based upon pure mathematical principles, and every problem or question arising in connection with it, is capable of the clearest possible solution or demonstration, just as is the simplest proposition to be found in Euclid's Elements.

The impression formed upon the eye by any object or point, is supposed to travel from one to the other in straight lines. This assumption is all that is required to constitute the study a mathematical one. For a picture to be a correct representation of any object, it is necessary that the rays of light should come from the several parts of the picture to the eye of the spectator, under the same circumstances of direction, strength of light, colour, and shade, as from the corresponding parts of the real object. A picture may be drawn upon a surface of any form, so that these conditions are fulfilled. The actual outline of the object as pictured, therefore, depends upon the form of this surface, as well as upon the form and position of the object itself; it is almost universally considered to be a vertical plane. Starting from these premises, Mr. Abbott proceeds to lay down the more general deductions, and to explain the simplest methods of construction applicable to all imaginable cases, and this, too, in a manner clear and intelligible to those at all conversant with Euclid. Indeed, as stated in the title-page, the matter is "divested of all difficulty," and further commendation is unnecessary.

We now turn to Mr. Parsey's book. We have already given a portion of the title of this work, but, as it is somewhat amusing, we here supply it *in extenso*:—"The Science of Vision, or Natural Perspective; containing the true language of the eye, necessary in common observation, education, art, and science; constituting the basis of the art of design, with practical methods for fore-shortening and converging, in every branch of art; the new elliptical or conic sections, laws of shadows, universal vanishing points, and the new optical laws of the camera obscura, or daguerreotype; also, the physiology of the human eye, explaining the seat of vision to be the iris, and not the retina." Opposite to this title is a frontispiece with this inscription—"This plate is a copy of the first picture ever drawn with optical accuracy."

As might be expected from his title, Mr. Parsey will have it that all other teachers of perspective but himself are wrong. His book is, in fact, written for the sole purpose of proving that he is right. According to common rules, vertical lines are always represented as vertical. Mr. Parsey says they should converge; but he premises his arguments by begging the very question at issue. According to common rules, the plane of the picture is always supposed to be vertical; and if Mr. Parsey will attentively consult Mr. Abbott's book, he will find it mathematically proved that in this case the lines should *not* converge; or, if he will take the trouble to measure, on a vertical pane of glass, the apparent dimensions of any object with vertical sides, situated beyond, he will arrive at

the same result. Mr. Parsey, however, in various cases, supposes the plane of the picture *not* to be vertical; in which cases, the direction of the lines will be different, as any one at all acquainted with the subject will allow—and Mr. Parsey might have saved himself the labour spent in proving it. His book would have been written to some purpose, if the author had given a valid reason for making the plane of the picture not vertical. It seems to us a mere matter of choice or convenience, whether the plane of the picture be vertical or not. Mr. Parsey would have a different position of the plane for each individual picture. Imagine the effect upon a picture gallery, the pictures standing forward from the walls in every conceivable variety of position; imagine the labour and calculation requisite in the picture-hangers, and the care necessary to give each picture its appropriate inclination. We certainly think the common uniform plan is, to say the least, the more convenient. Mr. Parsey lays a great stress upon the equalizing of the rays of light—that is, the so disposing the plane of the picture, that lines drawn from the top and bottom of it to the eye shall be equal. If we are really to equalize the rays, we must make our drawings upon hollow spheres, the eye being supposed the centre; we cannot equalize the lines from a plane—the line drawn perpendicularly from the eye to the plane is the shortest, and all the rest vary in length. Are the rays of light equal when we look at any natural object? Why, then, should we seek to equalize them in the picture? Were we to draw upon spheres, we should require to draw in curvilinear perspective, which has also been proposed as the correct method; but it is so only when the surface of the picture is spherical. As before said, the outline of the pictured object depends upon the position and form of the picture surface. Mr. Parsey brings forward the fact, of the lines in daguerreotype pictures being convergent; but there is not the slightest argument deducible from this in favour of his views, since the daguerreotype camera may be disposed so as to make the lines converge or not at pleasure.

As to the hack of the iris being the seat of vision, and receiving the image *reflected* by the retina, we leave the question to the physiologists, but we doubt if they will be prepared to admit Mr. Parsey's conclusions. We always understood that the seat of vision was in the brain, and that the eye was but an instrument for transmitting the external impressions. It is indeed supposed that there is no coloured image formed in the eye, because the retina is black; and we know, that in a common camera no picture will be seen upon a black piece of paper. This being the case, Mr. Parsey's theory seems to totter to the ground at once.

CORRESPONDENCE.

AMERICAN PATENT LAWS.

In part 62 of the *Practical Mechanic's Journal*, you have given an excellent synopsis of the American Patent Law; but the article is slightly in error, where it is stated that an applicant can refer a disputed case to a Board of Examiners. The Act of 1839, Sect. 11 and 12, repealed so much of the previous Acts as related to a Board of Examiners, and re-enacted that all appeals from the decision of the Commissioner be referred to the Chief Justice of the district Court of the United States, for the district of Columbia.

New York, 1853.

G. M. K.

ECONOMICAL MARINE ENGINES.

Will you, or any of your readers, be kind enough to explain, or refer me to any explanation, if such has been given, of the following from Bourne on the screw?—

"I have already mentioned, that if the power of any given vessel be doubled, her speed will be increased nearly in the proportion of the cube root of 1 to the cube root of 2. A vessel, therefore, which maintains a speed of 10 knots with any given power, will maintain a speed of 12½ knots with twice the power. I proposed that the power of all the companies' vessels running on important lines should be doubled, wherever the usual speed did not exceed 10 knots an hour.

"Now, this duplication of the power I proposed to accomplish without touching the existing engines at all, and, as I have already mentioned, I proposed to apply a screw in the stern of the vessel, which was to be driven by separate direct-acting engines of its own. The screw engines would not have had either air-pumps or condensers; but the steam from the boilers was to enter the screw engines first, and after having given motion to them, would have passed into the paddle engines, where it would have been condensed in the usual manner.

"By this arrangement, the steam would have been used twice over, and twice the amount of engine power would have been exerted in the hour, without any increase in the consumption of coal."

It appears to me, under these circumstances, that steam-boat companies would best study their own interest, if, in future cases, after having determined upon the amount of power they intend putting into a boat, they were to halve it—in fact, make condensing engines of half the power necessary; making up the other half by putting in a pair of high-pressure engines, as both engines will work with the same amount of steam which one pair alone would require; and consequently, according to Bourne, “without any increase in the consumption of coal,” the aforesaid companies would save 50 per cent. of coal in all new boats.

BRUNMAGEM.

[The statement to which our correspondent refers, certainly reads absurdly enough. Translated into plain language, it amounts to nothing more than a rather florid recommendation of the expansive system. It is to be lamented that the author did not say so, instead of over-labouring his text with matter quite foreign to the point.—ED. P. M. JOURNAL.]

FEED APPARATUS FOR STEAM-BOILERS.

The annexed sketch represents a side elevation of an apparatus which I have contrived for supplying boilers with water, in a continuous manner, when under working pressure, without pumping or overhead cisterns. It consists of a steam and water chamber, A, set edgewise alongside the boiler to be supplied, and having a shaft, B, passing horizontally through it, and driven at a slow rate. This shaft carries a cellular disc, or wheel, C, with recesses, D, all round its periphery, which is turned true to fit to the correspondingly curved internal surface of the chamber, A. The chamber is rounded only on one side, where the suction-pipe, E, enters from the feed-

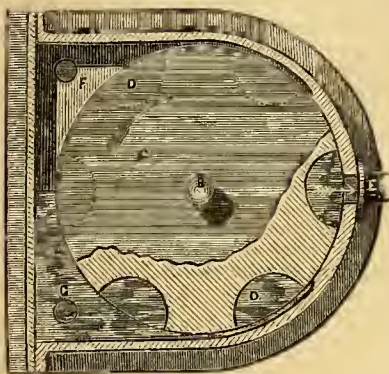

water reservoir, so that the frictional contact of the disc is confined to that side. The sides of the disc work quite free of the case. At F is a small pipe, forming a communication between the upper part of the chamber and the steam-space of the boiler; and at G is a similar pipe, opening from the lower part of the chamber into the water-space of the boiler. The internal pressure is thus balanced; and it will be seen that, as the wheel, C, slowly revolves, it continually fills its cells or buckets, D, from the water-pipe, E; and the water so taken in is then left in the chamber, whence it flows into the boiler, up to the level at which it stands in the chamber. Such a feeder will require no attendance, as, when the water gets above the wheel, it will take in no more.

HENRY HUCK.

Holme, Burton, Westmorland, Sept., 1853.

PROCEEDINGS OF SCIENTIFIC SOCIETIES.

THE BRITISH ASSOCIATION AT HULL.

SEPTEMBER 7.

MR. W. HOPKINS, M.A., PRESIDENT.

The proceedings were opened by a meeting of the general committee—Colonel Sabine presiding. The report of the council showed that active steps had been taken in reference to a plan by which the transactions of different scientific societies might become part of one arranged system, and the records of facts and phenomena be rendered more complete, more continuous, and more systematic than at present.

The committee established for procuring a telescope of large optical power, for the observation of the southern nebulae, have decided on the nature and size of the instrument; and hopes are entertained that the necessary funds will be included in the next parliamentary estimates.

The following gentlemen have accepted office for the year:—

Section A.—President, the Dean of Ely, F.R.S.; Vice-Presidents, W. R. Grove, Esq., F.R.S.; Col. Sabine, F.R.S.; Rev. Dr. Scoresby, F.R.S.; Professor Stokes, F.R.S.; Secretaries, Professor Stevelly; Benjamin Blaydes Haworth, Esq.; J. D. Sollitt, Esq.; J. Welsh, Esq.

Section B.—President, J. F. W. Johnston, M.A., F.R.S., Professor of Chemistry, Durham; Vice-Presidents, Dr. Faraday, F.R.S.; Rev. Wm. Vernon Harcourt, F.R.S.; Dr. Andrews, F.R.S.; Dr. Daubeny, F.R.S.; J. P. Gassiot, Esq., F.R.S.; Secretaries, Professor Robert Hunt; Thomas J. Pearsall, Esq., F.C.S.; Henry Spence Blundell, Esq.

Section C.—President, Professor Sedgwick, F.R.S.; Vice-Presidents, James

Smith, Esq.; H. E. Strickland, Esq., F.R.S., &c.; Secretaries, Professor Harkness, F.G.S.; W. H. Dykes, Esq.; W. Lawton, Esq.

Section D.—President, C. C. Babington, M.A., F.R.S.; Vice-Presidents, G. A. Walker Arnott, LL.D., Professor of Botany, University of Glasgow; Sir W. Jardine, Bart., F.R.S.E.; Secretaries, E. Lankester, M.D., F.R.S.; Robert Harrison, Esq.; H. Munro, Esq.

Section E.—President, Robert G. Latham, M.D., F.R.S.; Vice-Presidents, Captain Sir J. C. Ross, R.N., F.R.S.; Right Hon. Lord Lonsborough, F.R.S.; John Conolly, M.D., F.E.S.; Col. Chesney, F.R.S.; Secretaries, Richard Cull, Esq.; Norton Shaw, M.D.; Rev. H. W. Kemp, B.A.

Section F.—President, James Heywood, Esq., M.P., F.R.S.; Vice-Presidents, Thomas Tooke, Esq., F.R.S.; F. G. P. Neison, Esq.; Secretaries, William Newmarch, Esq.; Edward Cbeshire, Esq.

Section G.—President, William Fairhair, Esq., C.E., F.R.S.; Vice-Presidents, Professor Hodgkinson, F.R.S.; George Rennie, Esq., C.E., F.R.S.; James Walker, Esq., LL.D., C.E., F.R.S.; Secretaries, James Oldham, Esq., C.E., M.I.C.E.; James Thomson, Esq., A.M., C.E.; Wm. Sykes Ward, Esq., F.C.S.

The invitations already given by Liverpool and Glasgow for the next two meetings were renewed; and Gloucester also extended its hospitality in a similar way.

From the treasurer's account, we find that the past year's expenditure has been £1489, leaving a balance in favour of the Association of £227. 19s. 11d.

ABSTRACT OF THE PRESIDENT'S ADDRESS.

Astronomical research still continues to prove to us how much more populous is that portion of space occupied by the solar system, than was suspected only a few years ago. Between the 23d of June, 1852, and the 6th of May, 1853, nine new planets were discovered, of which seven were found since the last meeting of the Association; and we have no reason to suppose that we have yet approximated to the whole number of these minor planetary bodies. All those which have been recently recognized appear like stars of magnitude not lower than the eighth or ninth, and are, consequently, invisible to the naked eye. The search for them has now assumed, to a considerable extent, a more systematic form, by a previous mapping of the stars up to a certain magnitude, and contained within a belt of a few degrees in breadth on either side of the ecliptic. This mapping of the ecliptic stars, from the eighth to higher magnitudes, is still comparatively limited; nor has the length of time during which any one portion, perhaps, of the space has been thus mapped, been sufficiently great to insure the passage through it, within that time, of any planet whose period is as long as the possible periods of those which may yet remain unknown to us.

There would seem to be a tendency in the human mind to repose on the contemplation of any great truth after its first establishment. Thus, after the undisputed reception of the theory of gravitation, and the complete explanation which it afforded of the planetary motions, men seemed to think little of any further revelations which the solar system might still have to make to us respecting its constitution, or the physical causes which it calls into operation. The recent discovery, however, of so many planets, shows how imperfectly we may yet be acquainted with the planetary part of the system; and the continual discovery of new comets seems to indicate that in this department still more remains to be done. These curious bodies, too, may possibly have to reveal to us facts more interesting than any which the planets may still have in reserve for us. The experience of these latter bodies, if I may so speak, is more limited, and their testimony, consequently, more restricted. But they have already told us a noble tale. In moving, as they do, in exact obedience to the law of gravitation, and thus establishing that law, they have affirmed the highest generalization in physical science which it has been accorded to the human mind to conceive. At the same time, the approximate circularity of their orbits prevents their passing through those varied conditions to which comets are subjected. Thus, while the latter obey, in common with the planets, the laws of gravitation, they frequently present to us, in their apparent changes of volume, form, and general character, phenomena, the explanation of which has hitherto baffled the ingenuity of astronomers. One of the most curious of these phenomena has been recently observed in Biela's comet. This comet has a period of about six years and a half, and has been observed a considerable number of times on its periodical return to the neighbourhood of the sun. It appeared in November, 1845, and in the following January the phenomenon alluded to was observed for the first time. The comet had become divided into two distinct parts, with separate nuclei. Sometimes the one and sometimes the other appeared the brighter till their final disappearance. A complete discussion of all the observations which have been made on these comets during their last and previous appearances, is now in progress by Professor Hubbard of the Washington Observatory. The distance between the two nuclei was much increased on their last appearance. Judging from the apparent absence of all influence and sympathy between these bodies, it would seem that their physical divorcement, though without known precedent, is final and complete.

Stellar Astronomy continues to manifest a vigour and activity worthy of the lofty interest which attaches to it. Bessel had made a survey of all stars, to those of the ninth magnitude inclusive, in a zone lying between 45° of north, and 15° of south declination. Argelander has extended this zone from 80° of north to 31° of south declination. It comprises more than 100,000 stars. Last year was published also the long-expected work of M. F. G. W. Struve, containing a catalogue of stars observed by him at Dorpat, in the years 1822—43. They are principally double and multiple stars, which had been previously micrometrically observed by the same distinguished astronomer. Their number amounts to 2874; the epoch of reduction is 1830.

Notices have been brought before us, from time to time, of the nebulae observed through Lord Rosse's telescope. Almost every new observation appears to con-

firm the fact of that curious tendency to a spiral arrangement in these nebulous masses, of which mention has so frequently been made.

No one has contributed more to the progress of Terrestrial Magnetism, during the last few years, than my distinguished predecessor in this chair. Formerly, we owed theories on this subject much more to the boldness of ignorance than to the just confidence of knowledge; but from the commencement of the systematic observations which Col. Sabine has been so active in promoting, this vague and useless theorizing ceased, to be succeeded, probably ere long, by the sound speculative researches of those who may be capable of grappling with the real difficulties of the subject, when the true laws of the phenomena shall have been determined. Those laws are coming forth with beautiful precision from the reductions which Col. Sabine is now making of the numerous observations taken at the different magnetic stations; and it would seem that some of the curious phenomena of magnetism which have hitherto been regarded as strictly terrestrial, are really due to solar and lunar, as much as to terrestrial magnetism. It is beautiful to trace the delicate influences of bodies so distant, producing phenomena scarcely less striking, either to the imagination or to the philosophic mind, than the more obvious phenomena which originate in the great luminary of our system.

New views, which have lately sprung up respecting the nature of heat, are highly interesting theoretically, and important in their practical application, inasmuch as they modify, in a considerable degree, the theory of the steam-engine, the air-engine, or any other in which the motive power is derived immediately from heat; and it is correct theory alone which can point out to the practical engineer the degree of perfection at which he may aim in the construction of such machines, and which can enable him to compare accurately their merits when the best construction is arrived at. The new theory not only asserts generally the convertibility of heat into mechanical effect, and the converse, but also more definitely, that whatever be the mode of converting the one into the other—and whether heat be employed to produce mechanical effect, or mechanical force be employed to produce heat—the same quantity of the one is always the equivalent of the same quantity of the other. This theory is in perfect harmony with the opinions now very generally entertained respecting *radiant heat*. Formerly, light and heat were regarded as consisting of material particles continually radiating from luminous and heated bodies respectively; but it may now be considered as established beyond controversy, that light is propagated through space by the vibrations of an exceedingly refined ethereal medium, in a manner exactly analogous to that in which sound is propagated by the vibration of the air, and it is now supposed that radiant heat is propagated in a similar manner.

Many years ago, Gay-Lussac made an ascent in a balloon for the purpose of making observations on the air in the upper regions of the atmosphere; but it is only very recently that systematic observations of this kind have been attempted. Last autumn, four balloon ascents were made by Mr. Welsh, under the guidance of the distinguished aeronaut, Mr. Green. Attention was chiefly directed to the determination of the pressure, temperature, and moisture of the air at different altitudes. The decrease of temperature in ascending was very irregular, being changed even in some cases to an increase; but the mean result gives a decrease of 1° Fahr. for every 348 feet of ascent, agreeing, within 5 or 6 feet, with the result obtained by Gay-Lussac. An immense contribution, of which brief mention was made by my predecessor, has been made within the last few years to this science, by the publication of Prof. Dové's Isothermal Maps, giving us the temperature of the lowest portion of the atmosphere (that which determines the *climate* of every region) for nearly all accessible points of the earth's surface. These maps present a great number of isothermal lines—*i. e.*, lines passing through all those places which, at an assigned period of the year, have the same temperature, each line indicating a particular temperature, differing, by a few degrees, from those of the adjoining lines. We may easily conceive how a great ocean current of warm water from the tropics may affect the temperature of the atmosphere in the colder regions into which it may penetrate; but it is only since the publication of these maps that we have had any adequate idea of the extent of this influence, or been able to appreciate the blessings conferred on the shores of north-western Europe, and especially on our own islands, by the gulf-stream. This great current, though not always under the same name, appears, as you are probably aware, to traverse the Atlantic in a north-westerly direction, till it reaches the West India Islands and the Gulf of Mexico. It is then reflected by the American coast, and takes a north-easterly direction to our own shores, extending beyond Iceland into the North Sea. It is to the enormous mass of heated water thus poured into the colder seas of our own latitudes that we owe the temperate character of our climate; and the maps of M. Dové enable us not only to assert distinctly this general fact, but also to make an approximate calculation of the amount to which the temperature of these regions is thus affected.

My predecessor in his address, informed us of an application made to our Government by that of the United States, to adopt a general and systematic mode of observing phenomena of various kinds at sea, such as winds, tides, currents, &c., which may not only be of general scientific interest, but may also have an important bearing on navigation. The plan proposed by Lieut. Maury, and adopted by the American Government, is to have the required observations regularly made by the commanders of vessels sent out to sea. I am happy to be able to state to you, that our Admiralty have given orders for similar observations to be made by those who have command of English vessels; and we trust also that proper persons will be appointed, without delay, for the reduction of the mass of observations which will thus soon be accumulated.

The science of geology may be regarded as comprising two great divisions—the physical and the palæontological portions. The former may be subdivided into its chemical and dynamical branches. The chemical department has never made any great progress, though abounding in problems of first-rate interest—such, for

instance, as the formation of coal, the segregation of mineral matter constituting mineral veins of all descriptions, the processes of the solidification and crystallization of rocks, of the production of their jointed and laminated structure, and many others. Interesting experiments are not altogether wanting on points such as these, but not sufficient to constitute, as far as I am aware, a positive foundation and decided progress in this branch of the science. The dynamical, or, more strictly, the mechanical department of the science, has received a much larger share of attention.

One favourite subject of speculation in the physical branch of geology has been, at all times since the origin of the science, the state of the interior of our planet, and the source of the high temperature observed at all considerable depths beneath its surface. The terrestrial temperature, at a certain depth in each locality, (about 80 feet in our own region,) remains constant during the whole year, being sensibly unaffected by the changing temperature of the seasons. The same, of course, holds true at greater depths; but the lower we descend the greater is this invariable temperature, the increase being proportional to the depth, and at the rate of 1° Fahr. for about every 60 or 70 feet. Assuming this rate of increase to continue to the depth of 50 miles, we should arrive at a temperature about twice as great as that necessary to fuse iron, and sufficient, it is supposed, to reduce nearly the whole mass of the earth's solid crust to a state of fusion. Hence the opinion adopted by many geologists is, that our globe does really consist of a solid shell, not exceeding 40 or 50 miles in thickness, and an interior fluid nucleus, maintained in a state of fusion by the existing remains of the heat to which the whole terrestrial mass was originally subjected. The above estimate, however, of the thickness of the earth's solid crust, entirely neglects the possible effects of the enormous pressure to which the terrestrial mass, at any considerable depth, is subjected. It has been for the purpose of ascertaining the effects of great pressure that Mr. Fairbairn, Mr. Joule, and myself, have undertaken the experiments in which we have for some time been engaged at Manchester. At present our experiments have been restricted to a few substances, and those of easy fusibility; but I believe our apparatus to be now so complete for a considerable range of temperature, that we shall have no difficulty in obtaining further results. Those already obtained indicate an increase in the temperature of fusion proportional to the pressure to which the fused mass is subjected. In employing a pressure of about 13,000 lbs. to the square inch on bleached wax, the increase in the temperature of fusion was not less than 30° Fahr.—about one-fifth of the whole temperature at which it melts under the pressure of the atmosphere. We have not yet ascertained the degree in which the conductive power of any substance may be increased when solidified under great pressure. This point we hope to investigate with due care, and also to determine the effects on substances thus solidified, with respect to their density, strength, crystalline forms, and general molecular structure.

Some of the most interesting of recent discoveries in organic remains are those which prove the existence of reptilian life during the deposition of some of our oldest fossiliferous strata. An almost perfect skeleton of a reptile belonging to the Batrachians or Lacertians was lately found in the old red sandstone of Morayshire. The remains of a reptile were also discovered last year by Sir Charles Lyell and Mr. Dawson in the coal measures of Nova Scotia, and a batrachoid fossil has also been recognized in British coal shale. But the most curious evidence of the early existence of animals above the lower orders of organization on the face of our globe, is that afforded by the foot-prints discovered a short time ago in Canada by Mr. Logan on large slabs of the oldest fossiliferous rocks, those of the Silurian epoch. After these discoveries, few geologists will perhaps be surprised should we hereafter find that higher forms of animal life were introduced upon the earth during this early period, than have yet been detected in its sedimentary beds.

Many of you will be aware that there are two theories in geology, which may be styled the theories of *progression* and of *non-progression* respectively. The former asserts that the matter which constitutes the earth has passed through continuous and progressive changes, from the earliest state in which it existed to its actual condition at the present time. The theory of *non-progression*, on the contrary, recognizes no primitive state of our planet differing essentially from its existing state; the only changes which it does recognize being those which are strictly periodical, and therefore produce no permanent alteration in the state of our globe. With reference to organic remains, the difference between these theories is exactly analogous to that now stated with reference to inorganic matter. Each successive discovery, like those which I have mentioned, of the remains of animals of the higher types in the older rocks, is regarded by some geologists as an addition to the cumulative evidence by which they conceive that the theory of *non-progression* will be ultimately established; while others consider the deficiency in the evidence required to establish that theory as far too great to admit the probability of its being supplied by future discovery. Nor can the theory derive present support, it is contended, by an appeal to any properties of inorganic matter, or physical laws, with which we are acquainted. Prof. W. Thomson has recently entered into some very interesting speculations bearing on this subject, and suggested by the new theory of heat of which I have spoken. The heat of a heavenly body placed under the same conditions as the sun, must, it has been said, be ultimately exhausted by its rapid emission. This assertion assumes the matter composing the sun to have certain properties, like those of terrestrial matter, with respect to the generation and emission of heat; but Prof. Thomson's argument places the subject on better grounds, admitting, always, the truth of the new theory of heat. That theory asserts, in the sense which I have already stated, the exact equivalence of heat and motive power; and that a body, in sending forth heat, must lose a portion of that internal motion of its constituent particles on which its thermal state depends. Now we know that no mutual action of these constituent particles can continue to generate motion which might compensate for the loss of motion thus sustained. This is a simple deduction from dynamical laws and principles,

independent of any property of terrestrial matter which may possibly distinguish it from that of the sun. Hence, then, it is on these dynamical principles that we may rest the assertion, that the sun cannot continue, for an indefinite time, to emit the same quantity of heat as at present, unless his thermal energy be renovated from some extraneous source. The same conclusion may be applied to all other bodies in the universe, which, like our sun, may be centres of intense heat; and hence, recognizing no adequate external supplies of heat to renovate these existing centres of heat, Prof. Thomson concludes that the dispersion of heat, and, consequently, of physical energy, from the sun and stars into surrounding space, without any recognizable means of reconcentration, is the existing order of nature. In such case, the heat of the sun must ultimately be diminished, and the physical condition of the earth therefore altered, in a degree altogether inconsistent with the theory of *non-progression*.

If we are to found our theories upon our knowledge, and not upon our ignorance of physical causes and phenomena, I can only recognize, in the existing state of things, a passing phase in the material universe. It may be calculated in all, and is demonstrably so in some respects, to endure under the action of known causes, for an inconceivable period of time; but it has not, I think, received the impress of eternal duration in characters which man is able to decipher. The external temperature and physical conditions of our own globe may not, and probably cannot, have changed in any considerable degree since the first introduction of organic beings on its surface; but I can still only recognize in its physical state, during all geological periods, a state of actual though of exceedingly slow progression, from an antecedent to some ultimate state, on the nature of which our limited powers will not enable us to offer any conjecture founded on physical research. The theories, even, of which I have been speaking, may probably appear to some persons as not devoid of presumption; but, for many men, they will ever be fraught with deep speculative interest; and, let me add, no charge of presumption can justly lie against them, if entered upon with that caution and modesty which ought to guide our inquiries in these remote regions of physical science.

INSTITUTION OF MECHANICAL ENGINEERS.

JULY 27, 1853.

"On an Improved Governor for Steam Engines," by Mr. C. W. Siemens, of London.

"On Hollow Railway Axles," by Mr. J. E. M'Connell, of Wolverton.

"On an Improved Railway Joint Chair," by Mr. R. S. Norris, of Warrington.

MONTHLY NOTES.

ROTATORY FIRE-GRATE.—The very elegant grate which we have here illustrated, is the recently patented invention of Mr. M. S. Kendrick of Birmingham. The patent embraces the making a grate separate from the back of the fireplace;



making such grates portable and to rotate; making the back of the fireplace, which is immediately behind the grate, of a concave form, and with a reflecting surface; and fitting such grates in stoves for use with portable chimneys. The actual fuel-holder is ingeniously made in the form of a vase of open fretwork, and its base is furnished with a short vertical stud or spindle, on which it has liberty to

revolve in a supporting socket, so as to present any required side to the open room. The concavity of the grate back is so situated, that the focal line is coincident with the top of the vase; it may either be of freclay, earthenware, or cast-iron—glazing or enamelling being resorted to when cast-iron is not used—so that the heat may be properly reflected. The smoke passes off through a hole in the back of the upper part of the concavity; an arrangement which improves the draught very considerably, as the tendency to rarefaction of the air immediately in the neighbourhood of the concavity, speedily carries off sluggish vapours. Mr. Kendrick also shows his grate as adapted for public buildings, instead of a stove. The elegant vase-holder is preserved throughout all the several modifications.

LITTLE'S COOKING RANGE.—A very efficient apparatus, suitable either as a kitchen range or a ship's galley, has recently been provisionally protected under the new law, by Mr. John Little of Glasgow. It consists of a casing of cast or wrought-iron, lined internally with fire bricks or clay, forming the oven or cooking chamber. In a convenient part of this is placed the fire-grate, either divided off from the oven by a partition or wire-screen, or entirely left open. The oven is thus heated by the fire being inside, or partially inside, of the oven or cooking chamber. The casing is formed with a double top, the intervening space, forming the flue partitions, being so placed as to direct the heat to all parts, and finally to the chimney, situated at a convenient part of the top or end of the range, which is fitted with a damper in the usual way; or the casing may have only a single top without a flue, and the fire may have only one part or the whole of it brought into contact with the oven. The fire thus placed within, or partially within, the oven or cooking chamber, has a slide to lessen the heat when required, or to protect the oven from dust. A boiler, or hot closet, which may be subdivided, is so placed as to be heated either from the flue or from the fire. The smoke is carried off by a chimney, a damper being inserted for regulating the heat in the usual way.

CHINA A FIELD FOR BRITISH ENGINEERING.—What a country for railways, canals, gas companies, water companies, and all sorts of investments! The Chinese pay most admirably. The people have always been ready to adopt whatever improvements the jealousy of their Tartar rulers permitted them to import; and it appears, on the authority of Jesuit and other writers two hundred years ago, that aversion to change is not an original element of the Chinese character. We shall have steamers without end on the great rivers before long, with Chinese engineers, and with Chinese engines. The amount of internal travelling in China is such, that we are assured by those who have managed to penetrate into the interior, that there are continuous streams of travellers, on horse, on foot, and on litters, from Canton to the great wall, some fifteen hundred miles; in many parts so crowded as to impede one another, and even in the mountain passes so numerous, as to leave no traveller out of sight of others, before and behind. Among these are long lines of merchandise. What a case of railway traffic! Our children may see China as much a network of railways as England itself.—*Times*.

WHAT IS COAL?—The Torbane Hill coal estate, in Linlithgowshire, will long be intimately connected with this question. The actual details of the extraordinary trial, of which it was the cause, are, in themselves, a remarkable subject for comment, quite as peculiar, indeed, as the primary question leading to the contest. The plaintiffs in the case were the Messrs. Russell, coalmasters, of Falkirk; and the defendants were Mr. W. Gillespie—the inventor of the "Inclinometer," illustrated in our July part—and his wife, as heiress of the estate. The record showed that, by a contract for a lease, entered into in 1850, it was agreed that the plaintiffs should grant to the defendants a lease of "the whole coal, ironstone, iron ore, limestone, and fire-clay, but not to comprehend copper or any other minerals" in the estate, for a period of twenty-five years, at certain royalties for the first year, and £300 a year or the royalties, at the option of the plaintiffs, every year afterwards. The defendants were, of course, to incur all the working expenses; no fixed rent being exigible for the first year, for which period the royalties on the produce actually raised should alone be paid. But when coal or iron was found in a profitably workable condition, a formal lease was to be entered into. On this the defendants entered, and are still in possession; but no formal lease has, so far, been executed. The allegations of the plaintiffs were to the effect, that although coal, ironstone, and clay had been met with in workable condition, the defendants had confined their operations to the working of an argillaceous bituminous mineral, which had not been let to them, and formed no part of the agreement. Prior to the date of the action, 19,000 tons, of 22½ cwt. to the ton, of such mineral had been so raised and disposed of as "gas coal." But the substance in question was of far greater value than ordinary coal, or any other of the minerals specified in the agreement; nor could it be classed as coal, its chemical and mineralogical constitution and qualities being essentially unlike those of common coal. That prior to the agreement no such substance was known, and, therefore, that the plaintiffs could not have let a mineral of which they had no cognisance. For the defendants, it was alleged that they had entered upon the land with the view of finding what is known as "Boghead coal," believing that the Torbane Hill strata were the same as on the adjoining Boghead estate. That the mineral which they had met with and raised was really of a class similar to the Boghead mineral, and, consequently, that they had only raised what they had covenanted to pay for. The important question then was, whether the mineral in dispute was or was not coal. For the plaintiffs, Messrs. Austen, Anderson, Brande, Rose, Dr. Anderson, Wilson, Cooper, and others, were examined as scientific evidence. For the defendants, Messrs. Johnson, Ramsay, Hoffmann, Fyfe, MacLagan, Gregory, Frankland, Dickinson, and others appeared. It was this evidence which gave so peculiar a colour to the proceedings. We never read anything so utterly conflicting as the analyses and details which formed the cross-fire between the two bands of witnesses. After their respective statements had been heard, and after the addresses of the counsel on both sides, the Lord President summed up—if an attempted digest of irreconcilable statements can be called a summing up—saying that the jury were to

determine whether the substance in question fell within the term whole coal in the demise, for it was not pretended that it came within any other terms specified in it. On the one side there were four geologists, who gave it as their opinion that it was not coal, and five on the other side who said it was coal, all speaking with perfect sincerity, according to what they, as geologists, classed as coal. Men of the highest reputation in geology and chemistry had been examined, but they differed very much in opinion. On one side there were five of the most eminent chemists, who had applied all their skill and energy to find out whether it was coal or not, and who had expressed themselves as clearly of opinion that it was not coal, while ten, equally eminent, on the other side, were of a diametrically opposite opinion. Is this substance, then, a coal or not, in the ordinary language of those who deal in it, and of the country? because, to find a scientific definition of it, after what has been brought to light for the last five days, would be, he said, indeed a difficult thing. In five minutes the jury returned a verdict for the defendants, thus establishing that, in their opinion, the mineral was really coal. That this was a just and honest verdict we fully and entirely believe. It appears to us that the Torbane mineral is simply a more gaseous kind of cannel than we are accustomed to meet with. No doubt it possesses other minor peculiarities, but none that are not reconcilable with the assumption that the stratum is simply coal in a transitional state. The most that can reasonably be said is, that a peculiar and unlooked-for hardship is entailed upon the unlucky proprietor, who is receiving a few pence per ton as royalty upon what sells in the market at something like four times the price of common coal, paying a similar low royalty. But this may be the fate of any speculation, and it seems a pity to have pursued so desperate a course as the attempted proof that the mineral was not coal. But what are we to think of the unqualified contradictions of the leading men who furnished the scientific evidence? Does that chapter of the trial's history read like a hint that mere laboratory experimentalists are of little avail in industrial practice; that theories are the night soap-bubbles with which the grown-up children of science amuse themselves, or does it suggest something worse?

REFLECTING FIRE-GRATES.—The peculiar form of domestic fire-grate, illustrated in the accompanying engravings, is the invention of M. Feret of Dieppe, who has devised it with the idea that the actual receptacle of the burning fuel might be

Fig. 1.



Fig. 2.

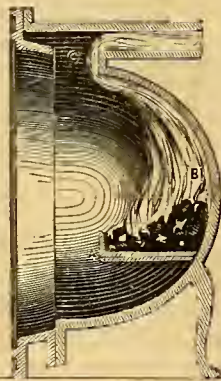

made the reflector for directing the heat into the apartment. Fig. 1 is a front view of such a grate in its plainest form, and fig. 2 is a transverse section to correspond. The fuel rests on grate-bars, A, in the usual manner, these bars being set in the reflector, B, which may be made up of right-lined surfaces; or it may be a hemispherical or differentially curved cavity, the smoke and heated air being directed forward along the upper side of the reflector, towards the external or front surface of the wall in which the grate is placed. Thence the current passes directly upwards through the thoroughfare, C, and proceeds to the flue. Such a shape might possibly have some effect where a very bright, clear, burning fuel is used; and in sunny France, the brisk wood fires would not, perhaps, have a very severe sully effect upon the original brilliancy of the mirror-like reflector. But in our dark country of coal, the carbonaceous deposits would soon rob it of all power of heat reflection.

MANUFACTURE OF "FLYERS."—ONIONS v. CROWLEY: ACTION FOR INFRINGEMENT.—This action, tried at the South Lancashire Summer Assizes, was for the recovery of damages for an alleged infringement of a patent, obtained by Mr. Onions in 1851, for the manufacture of flyers from cast-iron, subsequently annealed. A considerable amount of evidence was adduced on both sides; and, amongst the rest, Mr. Fletcher's patent of 1845, for "casting flyers of malleable iron and other metals," was quoted. On this Mr. Webster, for the plaintiff, commented on what he called the absurdity of "casting malleable iron." This was a sad betrayal of a lack of workshop knowledge on the part of the learned counsel. The terms "cast malleable," or "malleable cast" iron, are well understood terms in the vocabularies of old mechanics—meaning nothing more nor less than annealed cast-iron. The defendant's evidence went to show the total absence of novelty in the matter; and the jury took this view of it, by finding for the defendant.

BERDAN'S GOLD ORE PULVERISER AND AMALGAMATOR.—A novel contribution to an already long list of gold-working machinery has just made its appearance in this country, under the auspices of its inventor, Mr. Berdan, of the Novelty Iron Works, New York. The contrivance is the result of long and deep consideration of a difficult subject, Mr. Berdan having actually commissioned two engineers to

proceed to California, and there witness the realities of the case, and bring back material ideas on which to devise an efficient machine for pulverising, washing, and amalgamating. The pulverising process is effected in a large hemispherical iron vessel, rotating on an inclined spindle, and having within it a weighty iron sphere, connected by a pivot and bearings set in an inclined position loose upon the central spindle of the basin, in such a manner that its gravity causes it constantly to maintain the lowest possible position in the basin, whilst its axis of rotation, owing to the pivot connection, is inclined to that of the basin. And although its motion is due to that of the latter, it is not a mere rolling, but a species of spiral rubbing action, which is found to be very effective in reducing the ore. The basin is made to revolve by suitable gearing, a ring of teeth being cast or fitted on the outside of it for this purpose. A quantity of mercury lies in the bottom of the basin, and the ore is reduced to powder entirely beneath its surface, so that the particles of gold are brought into immediate contact with the mercury, whilst the earthy matter rises to the surface, and is washed away by water running through the basin, and kept in a constant state of agitation by the motion of the latter. As heat considerably strengthens the affinity of the mercury for the gold, a furnace is employed in connection with the apparatus. This is of a conical shape, and rests by its lower smaller end on a collar upon the basin spindle, just above the step. This machine is so vast an improvement upon those previously employed, that whilst they only extracted from 30 to 40 per cent. of the gold in a given quantity of quartz, the most searching chemical analysis has been unable to detect any gold remaining in the "tailings," or worked matter, from Mr. Berdan's machines, and these are, moreover, very profitably employed in reworking the tailings from other machines. In fact, in the words of an American contemporary, the yield of the gold regions may be considered as more than doubled by this machine.

LAWSON'S COMBING-GILL DRAWING FRAME.—The flax machine to which we have given this name, is the invention of Mr. Edward Lawson, the machinist, of Leeds. It consists of the combination of what is known as "Heilmann's combing machine," with the "screw-gill," or "circular-gill," drawing head. Instead of taking the combed flax sliver as it comes from the machine, and putting it at this stage into a can, or winding it upon a hobbler, Mr. Lawson takes the sliver from each bead, and passes them at once through the screw or circular-gill drawing frame, collectively. By this treatment, the sliver is rendered more even, and it holds together much better than the undrawn sliver. The drawing head is placed in the position occupied by the last delivery rollers, and is driven by the same shaft, or by gearing from the main shaft; the speed being of course arranged so, that the drawing apparatus shall take up the sliver as fast as it is delivered by the operating rollers.

COMPOSITE DRIVING BANDS FOR MACHINERY.—Mr. W. Paton, a rope manufacturer of Johnstone, is now making what we have termed "composite driving bands," made up of a series of cotton bands or cords, to work as a substitute for the common leather or gutta percha bands, at present employed for all kinds of pulley gearing. He takes the common cylindrical cotton hanking, such as is used for the various drum and spindle movements in cotton-mills, and sews or otherwise attaches several parallel lengths of this material together, so as to produce a flat driving band, resembling the ordinary flat ropes for mining purposes. Various classes of simple banding or cordage may be used as the nucleus from which to make these composite bands, but the common cotton-mill banding is preferable, as well for its cheapness as its efficient driving action. The round strands, when fastened together side by side as we have described, are rolled flat, giving to the finished band a transverse section, resembling that of the common leather strap.

EQUILIBRATED SHIPS' TABLES.—A curious contrivance has been lately patented by Mr. John Sayers, of Poplar, in connection with ship furniture, such as tables, and apparatus for supporting loose articles. With an ordinary table, the sea-going passenger constantly runs the risk of unshipping his teacup, or losing sight of his newly-charged cover at the dinner-table, from the lurching of the vessel. Mr. Sayers mitigates this evil, by arranging his tables so that their supporting surfaces shall always maintain their horizontal level. Fig. 1 of our engravings represents an end view of a ship's dining-table, so fitted as placed fore and aft; and fig. 2 is

Fig. 1.

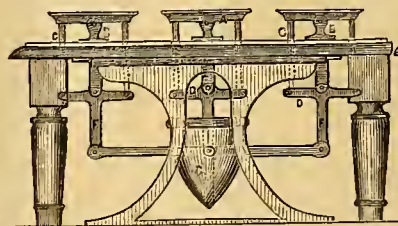
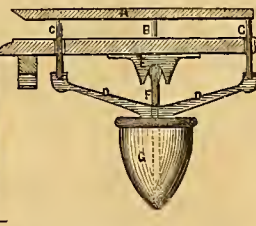

Fig. 2.



a transverse section of the table disposed athwart ship. At A are small tables, or platforms, supported at each end on hinge joints, B, attached to the table framing; and to the under sides of these tables, A, are attached the vertical pieces, C, sliding freely through holes in the fixed top of the table framing, and resting on the ends of the angular suspension pieces, D, beneath. These suspension pieces are carried on hinge pieces, E, fast to the under side of the ordinary table top. From the centre of the suspension pieces, D, arms, F, project downwards to carry the weight, C. It is evident that the surfaces, A, which are the supporting platforms for the loose articles in use, are thus kept at their exact level under all circumstances of the ship's motion, just as the common lamp or compass is sustained upon its universal joint.

CONSOLIDATED SODA WATER.—A curiosity in saline drinks—termed by the inventor, M. Lamplough, the consulting chemist of Mecklenburg Terrace, Gray's Inn Road, "consolidated soda water"—has just made its appearance. Aerated, or gassed, water is common enough, but not so real soda water. M. Lamplough, however, now gives us the true article, in the very portable condition of a ready-prepared powder, from which we can always obtain an "effervescing pyretic saline" draught of unvarying quality. A small bottle, with a cork-fitted stopper, holds twenty-four such draughts, in the shape of a powder, a teaspoonful of which, mingled in a glass of water, disengages a greater amount of carbonic acid gas than is producible by any ordinary means. The powder is, indeed, carbonic acid gas solidified, a substance being added for the perfect preservation of the gas. So convenient a means of obtaining a cool effervescing fluid carries its own recommendation with it.

PROVISIONAL PROTECTIONS FOR INVENTIONS

UNDER THE PATENT LAW AMENDMENT ACT.

When the city or town is not mentioned, London is to be understood.

Recorded March 26.

727. Alexander Prince, 4 Trafalgar-square, Charing-cross—Improvements in carriages.—(Communication.)

Recorded May 18.

1210. George Underwood, Stichill, Roxburghshire—Improvements in preparations from sulphate of iron, to be employed as medicines.

Recorded May 26.

1290. Edward White, Ipswich, Suffolk—Improvements in arrangements for supplying water to towns and other places.

Recorded May 28.

1314. George Harriott, Islington, Frintshury—Improvements in agricultural implements employed in crushing and rolling land, and in frames for the same.

1324. John H. Johnson, 47 Lincoln's-inn-fields, and Glasgow—Improvements in removing the gummy or glutinous matter from textile and other materials.—(Communication from Messrs. Alcan and Limet, Paris.)

Recorded May 31.

1337. Hesketh Hughes and William T. Denham, Cottage-place, City-road—Improvements in pianofortes.

Recorded July 13.

1667. Arnold Morton, Cockerill's-buildings, Bartholomew-close—Improvements in the manufacture of paints, pigments, and materials for house painting, paper staining, and decorative purposes generally.

Recorded July 15.

1697. William E. Newton, 66 Chancery-lane—Improvements in machinery or apparatus for digging, excavating, or removing earth.—(Communication.)

Recorded July 18.

1710. Samuel Perks, 1 Walbrook—Improvements in the construction of portable metallic folding bedsteads, chair-bedsteads, chairs, sofas, couches, settees, and such like articles for the use of emigrants and others, and part of which improvements are applicable to ordinary bedsteads, sofas, couches, chairs, and such like articles in general.

Recorded July 21.

1723. John Lilley, Thingwall, Chester—Invention for separating the refuse vegetable matter contained in the stalk and leaves of the plantain species, and also trees grown in tropical climates from the fibrous material of the same, in order that the latter may be manufactured into ropes or cordage, and for other purposes, for which hemp and flax are used.

Recorded July 26.

1750. Charles F. Speiker, New York—Improvements in generating and fixing ammonia.

Recorded August 1.

1788. John Smeeton, Limehouse, Middlesex—Improvements in the manufacture of tablets and dial-plates, applicable to showing the distances of carriages travelling, barometers, compasses, and time-pieces.

Recorded August 2.

1801. John Griffiths, Stepside, Saundfoot, near Tenhy, Pembroke—Certain improvements in steam-engines.

1803. William L. Anderson, Norwood, Surrey—An improved propeller, and method of driving the same.

1804. William H. Clarke, 20 Great Marlborough-street—Improvements in the manufacture of a composition resembling papier maché and carton pierre, and applicable to the same purposes to which papier maché and carton pierre are applied, parts of which invention may also be applied to the construction of ships and boats, and roofing.—(Communication.)

1805. Antoine J. Quinche, Paris, and 16 Castle-street, Holborn—An improved apparatus for measuring distances travelled over by vehicles.

1808. Matthias E. Boura, Crayford, Kent—Improvements in supplying ships or other vessels with water, air, or hallast.

1809. George Richardson, Gutter-lane, Cbeapside—Improvements in stoves for warming or heating buildings.

Recorded August 3.

1810. Thomas Atkins, Oxford—Improvements in transmitting power and communicating motion to agricultural implements.

1811. Joseph C. Daniell, Bath—An improvement or improvements in preparing food and litter for cattle, pigs, and other animals.

1812. John Slack, Manchester—Improvements in reeds for looms.

1813. William E. Newton, Chancery-lane—Improved machinery for cutting card-board, paper, and other similar materials.—(Communication.)

1815. William S. Roden and William Thomas, Ebbw Iron Works, Monmouth—Improvements in rolling metals.

1816. John Macintosh, Fall-mill—Improvements in the construction of bridges, viaducts, and other like structures.

1817. Aristide M. Servan, 8 Philpot-lane—Improvements in the manufacture of soap.

1818. James Billings, 8 Luton-place, George-street, Greenwich—Improvements in roofing buildings.

1819. John Cumming, Glasgow—Improvements in printing shawls, handkerchiefs, piece goods, paper-hangings, and similar materials, and in the apparatus connected therewith.

Recorded August 4.

1820. William Hickson, Carlisle—Improvements in canal and river navigation, and in vessels to be used in such navigation, and in the mode of propelling the same.

1821. Charles H. Snell, Triangle, Hackney—Improvements in the manufacture of soap.

1822. George Armitage, Bradford—Improvements in the construction of presses.

1823. Charles B. Clough, Tyddyn, Flint—Improvements in machinery or apparatus for washing, scouring, cleansing, or steaming woven fabrics, either in the piece or garment, also felts or fibrous substances, and corn, roots, seeds, or similar matters.

1824. Richard B. Roden, Abersycham Iron Works, near Newport, Monmouthshire—Improvements in rolling iron and all other malleable metals and alloys.

1825. Thomas Moss, 24 Gainford-street, Islington—Improvements in printing bank notes, cheques, bills of exchange, and other documents requiring like security against being copied.

1826. Barthelemy Louis Francois Xavier Fléchelle, Paris—Certain improvements in the means of carrying, bedding, and bathing the injured, ill, or invalid persons.

1827. George F. Wilson, Belmont, Vauxhall, and Alexander I. Austen, Trinity-place, Wandsworth-road—Improvements in the apparatus used in the manufacture of mould candles.

Recorded August 5.

1828. Joseph Lallemand, Besangon, France—Invention of the manufacture of paper from peat.

1829. William Smith and Thomas Philips, Snow-hill, Middlesex—An improved hoiler.

1830. Richard Peters, Southwark—An apparatus or machine for ascertaining the distance traversed by cabs and other vehicles.

1832. Edward T. Bellhouse, Eagle Foundry, Manchester—Improvements in fire-proof structures.

1833. William Garforth and James Garforth, Dukinfield, Chester—Improvements in machinery or apparatus for manufacturing bricks.

1834. Robert Hunt, Cottage-place, Greenwich—An improved tile, and an improved method of making tiles.

1835. James L. Norton, 8 Holland-street, Blackfriars—Improvements in obtaining wool from fabrics in a condition to be again used.

1836. William E. Newton, 66 Chancery-lane—Improvements in the process of coating cast-iron with other metals, and the alloys of other metals.—(Communication.)

Recorded August 6.

1837. Martin Z. Just, Manchester—Improvements in machinery in bulling and dressing paddy or rice.—(Communication.)

1838. John Hughes, 34 Great George-street—Improvements in building or forming structures under water, or below the surface of the ground.

1839. John Marten, High-street, Marylebone—An improved shade for gas-burners and lamps.

1840. Auguste E. Loradoux Bellford, 16 Castle-street, Holborn—Improvements in the combination of glass with iron or other metals, to serve for the construction of floors, walls, roofs, or parts thereof, or of windows for buildings, and also of translucent pavements, lights for subterranean apartments, and for any purpose for which a translucent medium possessing great strength is desirable.—(Communication.)

1841. Richard B. Martin, Suffolk-street, Haymarket—An improved plate-warmer.

1842. Henry Southan, Gloucester—Improvements in ploughs.

1843. Robert Morrison, Newcastle-upon-Tyne—Improvements in apparatus for forging, shaping, and crushing iron and other materials, and for driving piles.

1844. Peter A. le Comte de Fontaine Moreau, 4 South-street, Finsbury, and Paris—Improvements in transmitting power.—(Communication.)

1845. John Green, 10 Queenhithe—Improvements in printing machinery.—(Communication.)

Recorded August 8.

1846. Richard Christy and John Knowles, Fairfield, Lancashire—Improvements in the manufacture of terry cloth, or other woven fabrics having looped surfaces, and in the machinery or apparatus connected therewith.

1847. William E. Newton, 66 Chancery-lane—Improvements in horse-shoes.—(Communication.)

1848. William Dickson, Carlisle—Improvements in the application of heat for baking and drying purposes, and in the generation of steam.

1849. Moses Poole, Avenue-road, Regent's-park—Improvements in regulating the flow and pressure of gas and other fluids.—(Communication.)

Recorded August 9.

1850. Thomas Y. Hall, Newcastle-upon-Tyne—Improvements in combining glass with other materials.

1852. William Rowan, of John Rowan & Sons, Belfast—Improvements in loom for weaving, and apparatus connected therewith.

1854. Louis H. Bruck, Mark-lane—Improvements in the construction of tunnels, sewers, drains, pipes, tubes, channels, and other like conduits, for hydraulic or pneumatic purposes.

1855. William Baines, Coverdale-terrace, near Birmingham—Improvements in railways.

Recorded August 10.

1856. Henry Peters, Birmingham—Improvements in pens and penholders.

1857. George Parsons, West Lamhrook—Improvements in steam-engines and boilers.

1858. James Burden, Stirling—An improved cock or tap.

1859. John G. Taylor, Glasgow—Improvements in desks, work boxes, dressing cases, tea caddies, and similar articles, and in the arrangements and fittings thereof.

1860. Jean P. A. Galibert, Paris, and 4 Trafalgar-square—An improved domestic telegraph.

1862. Thomas MacSweny, America-square—Improvements in the construction of ships and vessels.

Recorded August 11.

1863. Samuel Hall, 16 Chadwell-street, Pentonville—Improvements in furnaces.

1865. David Mushet, Coleford, Gloucestershire, and Edwin Whele, Shiffual, Salop—Improvements in propelling steam vessels or other vessels.

1866. John Rushbury, Wolverhampton, Stafford—A new or improved lock.

1867. Joseph B. Finncmore, Easy-row, Birmingham, and Edwin D. Chattaway, Camden-street, Birmingham—Improvements in apparatus for ascertaining or registering the number of persons travelling by omnibuses or other vehicles, or who may have entered in, or passed by out of, or through any particular place, vehicles, or building, during any given period.

1868. Thomas Dewsnup, Manchester—Improvements in obtaining motive power.

1869. Thomas K. Hall, Crewe—Certain improvements in forge hammers.

1870. Richard F. Brand, Willow-walk, Bermondsey—Certain improvements in fire-arms and ordnance.

1871. Henry P. Stephenson, Thurloe-place, West Brompton—Improvements in the construction of suspension bridges.

1872. Henry M. Naylor, 111 Montpelier-row, Bloomsbury, Birmingham—Improvements in affixing postage and other stamps.

1873. John D. Daniell, Hlyson-green, and John W. Bagley, Radford, Nottinghamshire—Improvements in the manufacture of lace fabrics.

1874. George Deards, Marlow, Essex—Improvements in lamps.

1875. Thomas F. Newell, Cloak-lane, Queen-street, Cheapside—Improvements in machinery for numbering the pages of books and documents.—(Communication.)
 1876. William Longmaid, Beaumont-square, Mile-end—Improvements in the manufacture of manure.
 1877. Hugh L. Pattison, Scots House, near West Boldon, Gateshead—Improvements in the recovery of sulphur from alkali waste.

Recorded August 12.

1878. Samuel Adams, West Bromwich, Staffordshire—A new or improved apparatus for regulating the supply of water to steam and other boilers, applicable also to regulating the supply of liquids to vessels and reservoirs in general.
 1879. Louis V. Caneghem, 6 Condit-street, Regent-street, and Paris—Improvements in fastening corsets by a mechanical hulk.
 1880. James Strong, Smethwick, Staffordshire—Improvements in furnaces for smelting ironstones and ores.
 1881. Thomas Turner and John F. Swinburn, Birmingham—Improvements in sights for rifles.
 1882. Edward Lavender and Robert Lavender, Deptford—An improved apparatus for preparing the materials employed in the manufacture of certain composition fire-lighters.
 1883. Read Holliday, Huddersfield—Improvements in lamps, and in lanterns used therewith.
 1884. Richard A. Brooman, 166 Fleet-street—Improvements in the manufacture of fuel.—(Communication.)
 1885. Richard A. Brooman, 166 Fleet-street—Certain new compounds, which may be employed for mouldings, frames, and many purposes to which wood, papier maché, plaster, gutta percha, and other like substances are applicable.—(Communication.)
 1886. Richard A. Brooman, 166 Fleet-street—A method of obtaining impressions from dies, and other engraved and figured surfaces, by stamping or pressure.—(Communication.)
 1887. Richard A. Brooman, 166 Fleet-street—A method of producing castings in malleable iron.—(Communication.)
 1889. Thomas Allan, Adelphi-terrace, Westminster—Improvements in electric conductors, and in the means of insulating electric conductors.
 1890. William L. Tizard, Algate—Improvements in the construction of thermometers and other like indicators.
 1891. William Aldred, Manchester, Richard Fenton, Prestwich, and William Crone, Salford, Lancashire—Certain improvements in separating or recovering the wool from cotton and woollen, or other similar mixed fabrics, whereby the wool is rendered capable of being again employed.
 1893. Horatio Wareham, Feoton, Staffordshire—Certain improvements in inlaying or ornamenting earthenware vessels.
 1894. Robert S. Barleest, Redditch, Worcestershire—Improvements in apparatus used in sewing.

Recorded August 13.

1895. Frederick Lipscombe, Strand—Improvements in evaporating.
 1896. John C. Boond, Manchester—Certain improvements in Jacquard apparatus.
 1897. John Perkins, Manchester—Improvements in the manufacture of oils.
 1898. George Peel, Manchester, and Robert Brownhill, same place—Improvements in air-pump buckets, and in valves for steam-engines and other purposes.
 1899. Chandos W. Hoskyns, Wroxhall, Warwickshire—Improvements in the application of steam to ventilation.
 1901. John Gwynne, Essex-wharf, Essex-street, Strand, and James E. A. Gwynne, same place—Improvements in the preparation or manufacture of fuel.
 1902. John Gwynne, Essex-wharf, Essex-street, Strand, and James E. A. Gwynne, same place—Improvements in the preparation of beet-root, for the manufacture of sugar, which improvements are also applicable to the preparation of other vegetables.
 1903. John H. Johnson, 47 Lincoln's-inn-fields, and Glasgow—Improvements in dyeing, or colouring textile fabrics and materials, and in the machinery or apparatus connected therewith.—(A communication from Emile Weber, Mulhouse, France.)
 1904. John H. Johnson, 47 Lincoln's-inn-fields, and Glasgow—Improvements in the manufacture or treatment of gutta percha, and in the application thereof.—(Communication from Louis F. A. Deseille, Paris.)
 1905. Edward J. Scott, Glasgow—Improvements in the manufacture of hoots and shoes.
 1906. Hesketh Hughes, Cottase-place—Improved method of producing cut and fancy patterns in velvets, silks, and other textile fabrics.

Recorded August 15.

1907. Joseph L. Talabot, Paris, and John D. M. Stirling, Larches, near Birmingham—Improvements in the manufacture of cast-steel.
 1908. Alexander Dalgety, Florence-road, Deptford—Improvements in rotary steam-engines.
 1909. George E. Dering, Lockleys—Improvements in electric telegraphs.
 1910. Archibald Douglass, Norwich—Improved machinery for stitching, hackatitching, and rinning.
 1911. Richard A. Brooman, 166 Fleet-street—A method of, and machinery for, redning wood and other vegetable fibres to pulp, applicable to the manufacture of paper, pasteboard, millboard, papier maché, mouldings, and other like purposes.—(Communication.)
 1912. James Stewart, St. Paul's-road, Camdden-square—Improvements in piano-fortes.
 1913. Benjamin Rankin, College-street, Islington—Improvements in propelling vessels.
 1914. Edward Finch, Bridge-works, Chestow, and Charles Lamport, Workington—Improvements in the masts and rigging of ships.
 1915. Joseph Martin, Liverpool—Improvements in mills for grinding corn and other grain.
 1916. John Atherton, Preston, and James Abbott, Accrington—Certain improvements in and applicable to machines for winding yarn or thread, called winding machines, used in the manufacture of cotton and other fibrous substances.
 1917. Peter Foxcroft, Salford—Certain improvements in machinery or apparatus for doubling cotton and other fibrous materials.
 1918. George Richardson, Shoreditch—Improvements in railway signals, and in the means of preventing accidents upon railways, and in the apparatus connected therewith.
 1919. William Hunt, Leebrook Chemical Works, near Wednesbury, Stafford—Certain improvements in manufacturing sulphuric acid.
 1920. Alfred V. Newton, 66 Chancery-lane—Improvements in the distillation and purification of rosin oil.—(Communication.)

Recorded August 17.

1921. John Heritage, Warwick—An improvement in the manufacture of bricks, pipes, tiles, coping, and such other articles as are or may be moulded in clay.
 1922. Samuel Perkes, 1 Walbrook—Improvements in the construction of cocks, and such like articles.—(Communication.)
 1924. Thomas C. Orden, Manchester, and William Gibson, same place—Improvements in machinery or apparatus for preparing, doubling, and twisting cotton and other fibrous materials.

1925. Thomas Kirkwood, Edinburgh—Improvements applicable to ventilation and other purposes.
 1927. George L. Fuller, 13 St. Mary's-road, Peckham—Improvements in steam-engines.
 1928. Joseph H. Mortimer, 1 Chester-place, Old Kent-road—Improvements in lamps.

Recorded August 18.

1929. Robert Clough, Liverpool—Improvements in the construction of ships and other vessels.
 1930. David Chalmers, Manchester—Improvements in machinery or apparatus for cutting the pile of woven fabrics.
 1931. David Harkes, Mere, Chester—Improvements in machinery or apparatus for mowing, reaping, or other similar purposes.
 1932. Alexis Pigé, Greek-street, Soho—Improvements in locks, and their keys.—(Communication.)
 1933. William Symes, Pimlico—An improved fruit-cleaning machine.
 1934. Jean Lamanjat, Paris, and 16 Castle-street, Holborn—Certain improvements in obtaining motive power.
 1935. Peter Fairbairn, Leeds—Certain improvements in beekling machines.
 1936. William Curtain, Retreat-place, Homerton—Improved machinery for printing textile fabrics, oil-cloths, leather, paper-hangings, and other similar fabrics or materials.
 1937. William Cornelius, Panton-street, Haymarket—Improvements in gilding porcelain, glass, and such like materials.—(Communication.)
 1938. Auguste M. M. de Bergevin, Paris—Improvements in the manufacture of coke, and in the apparatus connected therewith, and in treating the products obtained therefrom.—(Communication from Monsieur G. L. E. Buran, Paris.)
 1939. Thomas Hughes, Birmingham—Improvement or improvements applicable to writing-slates, pocket and memorandum books, and other such like articles.

Recorded August 19.

1940. Frederick W. A. de Faheck, 6 Portland-road—Invention for the construction of viaducts, bridges, lintels, beams, girders, and other horizontal structures and supports.
 1941. Alfred Lutwyche, Birmingham—An improved mode of manufacturing steel or other metallic pens.
 1942. Charles Watt, 15 Selwood-place, Old Brompton, and Hugh Burgess, 7 Percy-street, Bedford-square—Improvements in disintegrating and pulping vegetable substances.
 1943. George Heyes, Bolton—Improvements in looms.

Recorded August 20.

1944. James Kimberley, Birmingham—Improvement or improvements in raising and lowering various kinds of window blinds, and in opening and closing window and other curtains, applicable also to the raising and lowering, or winding and unwinding, of maps and other sheets or articles, and to the closing of doors.
 1946. Jean B. Polailon and François Maillard, both of Lyons—Improvements in the manufacture of starch.
 1947. Robert M. Stevier, Louviers, France, now in Manchester—Improved machinery for the manufacture of tery or cut-pile fabrics, parts of which are applicable to the weaving of other fabrics.

Recorded August 22.

1950. William Schmollinger, Gracechurch-street, and Edward G. Smith, Lamheth—Improvements in the means of converting reciprocating or rectilinear motion into rotary motion.
 1951. Samuel Lomas, Manchester—An improved silk-cleaner.
 1952. John Steven, Edinburgh—An improved axle-hox for railway carriages and waggons.
 1953. Auguste E. L. Bellford, 16 Castle-street, Holborn—Improvements in the manufacture of certain mineral oils and paraffine.—(Communication.)
 1954. Victor E. Warmont, Neuilly, France—Improvements in dyeing and ornamenting skins, fabrics, and other substances.
 1955. Frederick Osbourn, Albion-street, King's-cross—Improved machinery for cutting woven and other fabrics.

Recorded August 23.

1956. Charles Cowper, Southampton-buildings, Chancery-lane—Improvements in the permanent way of railways.—(Communication.)
 1957. William Brown, Glasgow—Improved mode of obtaining volatile products from bituminous coals, and other bituminous substances.
 1958. Moses Poole, Avenue-road, Regent's-park—Improvements in crushing and pulverizing quartz and other substances.—(Communication from T. B. Smith, Taunton, Massachusetts.)
 1959. James Webster, Leicester—Improvements in pressure gauges.
 1960. Thomas C. Medwin, Blackfriars-road—Improvements in steam-engine boilers.
 1961. William Kettle, Aberdeen—Improved construction of submarine lamp.
 1963. John Whiteley, Stapleford—Improvements in warp machinery for the manufacture of textile fabrics.
 1964. William Mann, Stapey—Improvements in the purification of gas, and in the treatment of the material used in such purification.
 1965. William M'Leish, Battersea—Invention of a machine for destroying weeds.

Recorded August 24.

1966. Auguste E. L. Bellford, 16 Castle-street, Holborn—Improvements in fire-arms.—(Communication.)
 1967. Benjamin H. Hine and Anthony J. Mundella, Nottingham, and Thomas Thomson, same place—Improvements in machinery for the manufacture of textile and looped fabrics.
 1968. Thomas Foster, Manchester—Certain improvements in machinery or apparatus applicable to etching or engraving upon plain, cylindrical, or other surfaces.
 1970. Thomas Hill, Glasgow—Improvements in the manufacture of hollow pipes or articles from plastic materials.
 1971. George Folland, 64 Watling-street, and George Mumby, Hunter-street, Brunswick-square, Middlesex—Improvements in machinery or apparatus for the manufacture of envelopes.
 1972. Alfred A. de R. Hely, Cannon-row, Westminster—Certain improvements relative to shades or chimneys for lamps, gas, and other burners.
 1973. Alfred Swonell, Kingston-on-Thames—Improved construction of tie for neckcloths and neck ribbons, applicable also to neck ribbons of caps and bonnets.
 1974. Edward Heard, Regent-street, Lamheth—A certain mixture or composition of chemical agents for rendering sea-water fit for washing, and for softening hard-water for similar purposes.
 1975. Charles C. Banks, Clapham—Improvements in lubricators.

Recorded August 25.

1976. Alfred B. Thompson, Richmond—A new or improved spring-door hinge.—(Communication.)
 1977. William Austin, 27 Holywell-street—Improvements in the manufacture of hocks of plastic materials for building purposes.

1778. John Shaw, Manchester, and Joseph Steinthal, same place—An improved manufacture of artificial manure.
 1779. George Davis, London—Certain apparatus for distinguishing genuine from counterfeit coin.
 1780. Richard A. Brooman, 166 Fleet-street—Invention of machinery for digging, breaking, and trenching land.—(Communication.)

Recorded August 26.

1781. Richard A. Brooman, 166 Fleet-street—Improvements in the treatment of wool and silk, and in machinery for preparing silk so treated.—(Communication.)
 1782. Eugene de Varroc, Great Chesterfield-street—Certain means of depriving caoutchouc of all unpleasant odour, and of imparting to it various agreeable perfumes.
 1783. Robert Wilson, Glasgow—Improvements in the treatment or finishing of textile fabrics.
 1784. William Watson, junior, Leeds—Improvements in apparatus for manufacturing prussiate of potash.

Recorded August 27.

1785. Richard Roberts, Manchester—Improvements in the construction of casks and other vessels.
 1786. Alexander L. Bargnano, New York, now Hotel de Versailles, Leicester-place—Improvements in the manufacture of paper and pasteboard.
 1787. William Hargreaves, Bradford—Improvements in machinery for preparing and combing wool, hair, flax, silk, and other fibrous substances.
 1788. Charles W. Lancaster, New Bond-street—A method of, and machinery for, manufacturing or producing certain descriptions of gun and pistol barrels.
 1789. James Hill, Stalybridge—Certain improvements in machinery used for spinning, doubling, and winding cotton, wool, flax, silk, and other fibrous materials.
 1790. Rodolphe Helbronner, Spring-terrace, Vauxhall-walk, Lambeth—Invention of a chemical light, and apparatus for manufacturing the same.
 1791. John D. M. Stirling, Larches, near Birmingham—Improvements in the manufacture of rails and parts of railways, and tyres of railway wheels.
 1792. Henri G. Collier, Paris—Improvements in rotary pumps.
 1794. Alfred V. Newton, 66 Chancery-lane—Improved construction of steam-hammer.—(Communication.)
 1795. George Robinson, Newcastle-upon-Tyne—Novel application of the slags or refuse matters obtained during the manufacture of metals.
 1796. Edward Lacy, Handsworth, and William Wilkinson, Nottingham—A new description of cloth or fabric, applicable to most purposes to which woven and knitted fabrics are applied.
 1797. Josiah Hornblower, Poplar—Improvements in machinery for steering vessels.

Recorded August 29.

1798. John Foss, 15 Aldgate—Improvements in printing apparatus.
 1799. Adolph Berend, 3 Fenchurch-buildings—Improvements in instantaneous light apparatus.—(Communication.)
 2000. Joseph Cundy, 21 Victoria-road, Kensington—Improvements in kitchen ranges and cooking apparatus.
 2001. Edward F. Gribbon—Improvements in window frames and sashes.
 2003. Peter A. Le Comte de Fontaine Moreau, 4 South-street, Finsbury, and Paris—Certain improvements in the production of electricity.—(Communication.)

Recorded August 30.

2005. John Bald, Carsehridge Distillery, Alloa, and Charles Maitland, same place—Improvements in distilling.
 2007. Charles Goodyear, Avenue-road, St. John's Wood—Improvements in combining india-rubber with other matters for writing, marking, and drawing.—(Partly a communication.)
 2008. Charles Goodyear, Avenue-road, St. John's Wood—Improvements in rules, graduated scales, and measuring instruments.
 2009. Charles Goodyear, Avenue-road, St. John's Wood—Improvements in the manufacture and ornamenting or coating of articles, when compounds, containing india-rubber, are used.
 2010. Joseph Cundy, 21 Victoria-road, Kensington—Improvements in gas stoves.
 2011. James Picciotto, Crosby-square—Improvements in burning and returning animal charcoal.—(Communication.)
 2012. Alfred V. Newton, 66 Chancery-lane—An improved process of dyeing, part of which process is also applicable to bleaching.—(Communication.)
 2013. William E. Newton, 66 Chancery-lane—Improved machinery for cleaning bran or other offal obtained during the manufacture of flour.—(Communication.)
 2014. William E. Newton, 66 Chancery-lane—Improved machinery for cleaning grain and seeds.—(Communication.)

Recorded August 31.

2015. Ezra W. Burrows, Pentonville—Improvements in the construction of cranes and other machines for raising heavy bodies.
 2016. Astley P. Price, Margate, Kent—Improvements in treating wash waters containing soap, oils, saponified or saponifiable materials, and in obtaining products therefrom.
 2017. Thomas Dawson, King's Arms Yard, and Thomas Restell, Strand—Improvements in fishing-rods.
 2018. Grignon Meunier, Paris—Improvements in carriage-clocks.
 2019. Edward Smith, Love-lane—An improved mode of manufacturing carpets.
 2020. William E. Newton, 66 Chancery-lane—Improved machinery for reaping and gathering corn, grain, and other agricultural produce.—(Communication.)
 2021. William E. Newton, 66 Chancery-lane—Improved machinery for making barrels and other casks.—(Communication.)
 2022. William B. Johnson, Manchester—Improvements in steam-engines, and in apparatus connected therewith.
 2023. Henry J. Liffie and James Newman, Birmingham—Improvements in the manufacture of buttons.
 2024. John P. Grazebrook, Audnam, Stourhidge—Improvements in the working barrels of pumps, which improvements are also applicable to lining other metallic tubes.
 2025. Richard A. Brooman, 166 Fleet-street—An improvement in paddle-wheels.—(Communication.)

Recorded September 1.

2026. John Macintosh, 12 Pall-mall—Improvements in breakwaters.
 2027. Robert Oxland, Plymouth—Improvements in the manufacture of manure.

Recorded September 2.

2028. John Hinks and George Wells, Birmingham, and Frederick Dowler, same place—New or improved machinery, to be used in the manufacture of metallic pens and penholders.
 2029. John Tayler, Manchester, James Griffiths, Wolverhampton, and Thomas Lees, Stockport—Certain improvements in steam-boilers, and in apparatus applicable thereto, and to be used therewith.
 2030. Barthélemy Anrie, Grenelle, France, and 16 Castle-street, Holborn—New application of sulphate of lime to the fabrication of the mosaics and incrustations, and for any new processes of coloration of certain varieties of this substance.

2031. James P. Pritchett, younger, York—Improvements in window sashes and shutters.
 2032. Augustino Carosio, Connaught-square—Improvements in obtaining power by the aid of an electric current, for motive and telegraphic purposes.
 2033. John Sibley and Thomas Sibley, Ashton-under-Lyne—Improvements in machinery or apparatus for cutting discs or circles out of plates or sheets of metal or other substances.
 2034. William Ashton, Manchester, and William B. Harvey, Salford—Certain improvements in machinery or apparatus for manufacturing braid.

Recorded September 3.

2035. John T. Jewiss and Daniel Jewiss, Horsleydown—An improvement in furnaces.
 2036. Ebenezer Dobbell, Hastings—Improvements in clocks or timekeepers, and parts connected therewith.
 2037. Thomas Walker, Birmingham—Improvements in rotary engines, to be worked by steam or other fluid.
 2038. Albert Nagles, Ghent, Belgium—Certain improvements in machinery or apparatus for washing, bleaching, dunging, and dyeing woven fabrics.
 2039. Gage Stickney, Hanover-street, Pimlico—An improved construction of blower.—(Communication.)
 2040. Gage Stickney, Hanover-street, Pimlico—Improved machinery for forging metals.—(Communication.)

Recorded September 5.

2041. John Doyle, 17 Cambridge-street, Paddington—Invention of the waterproofing of boots and shoes.
 2043. John Smalley, Bishopgate, Lancashire, and Washington Smirk, Ince—An improvement in railway carriage axles.
 2044. John H. Johnson, 47 Lincoln's-inn-fields, and Glasgow—Improvements in the manufacture of stays or corsets.—(Communication from Adolphe G. Geresme, Paris.)
 2045. William E. Newton, 66 Chancery-lane—Improved machinery in weaving terry fabrics.—(Communication.)
 2046. William E. Newton, 66 Chancery-lane—Improvements in breech-loading guns.—(Communication.)

Recorded September 6.

2047. Thomas B. Upfill, Birmingham, and William Brown, same place—An improvement or improvements applicable to metallic hedsteads, couches, chairs, and such other articles as are or may be used for sitting, lying, or reclining upon.
 2048. Lemuel W. Wright, Charlford, Gloucestershire—Improvements in reaping and gaiting machines.
 2049. André Calles, Southwark-square, Surrey—Improvements in manufacturing typographic characters.
 2050. John Kerfoot, Lower Darwen, Lancashire—Improvements in machinery for spinning cotton or other fibrous substances.
 2051. Henry Wilkinson, Tottenham-news—Improvements in the construction of air-furnaces, parts of which improvements are applicable to other furnaces.
 2052. James Davis, Low Furness Iron Works, near Ulverston, Lancashire, and Robert Ramsay, same place—An improved engine to be worked by steam, air, or water.
 2053. Thomas Pope and Edward Bufton, Birmingham—Improvements in buttons, and which improved buttons they propose to designate by the name of 'Buffalo Buttons.'

Recorded September 7.

2055. Isaac Smith, Birmingham, and Alfred Sommerville, same place—Improvements in metallic pens and pen-holders.
 2056. Joseph Alsop, Huddersfield, and Edward Fairhair, Kirkstons Mills, Mirfield, Yorkshire—Improvements in baking bread.
 2057. John G. Fletcher, Accrington, Lancashire, and William Peel, same place—Improvements in looms for weaving.
 2058. David Law, Glasgow, and John Inglis, same place—Improvements in moulding or shaping metals.
 2059. William J. Smith, Stretford, Lancashire—Certain improvements in buttons or other such fastenings, and in applying or affixing them to wearing apparel.
 2060. Weston Grimshaw, Morsley, county Antrim, and Ellis Rowland, same place—Improvements in the manufacture of bricks.
 2061. George E. Ashton, Middlesex—Converting certain refuse materials into yarn, for the manufacture of wools and other fabrics.
 2062. Benjamin Hustwayte, Hockley-street, Homerton, and Richard J. P. Gibson, Upper Brunswick-street, Hackney—An improved composition or compositions applicable to the manufacture of bricks, tiles, and other moulded articles.

Information as to any of these applications, and their progress, may be had on application to the Editor of this Journal.

DESIGNS FOR ARTICLES OF UTILITY.

Registered from 11th August, 1853, to 14th Sept., 1853.

August 11th,	3498	J. R. Murphy and P. Murphy, Dublin,—“Reclining chair.”
18th,	3499	S. Bremner, Carlisle,—“Bag or pouch.”
19th,	3500	T. D. Mills, Pentonville,—“Filter.”
23d,	3501	C. Palmer, Islington,—“Cobler.”
25th,	3502	J. Cooper, Birmingham,—“Joiner's brace.”
28th,	3503	S. Van Kildum Priory,—“Pin-case.”
30th,	3504	W. and W. Field, Redditch,—“Needle-casket.”
31st,	3505	Cox and Wilson, Oldham,—“Steam-engine cylinder.”
Sept. 3d,	3506	T. H. and G. F. Busbridge, East Malling,—“Paper-roller.”
6th,	3507	J. Sheldon, Birmingham,—“Letter-balance.”
8th,	3508	T. Turner and J. F. Swinburn, Birmingham,—“Tail-pin breech.”
10th,	3509	Doulton and Watts, Lambeth,—“Jar.”
12th,	3510	W. Aston, Birmingham,—“Button.”
14th,	3511	J. W. Jones and W. Westley, Holborn,—“Antigropelos.”

TO READERS AND CORRESPONDENTS.

A SUBSCRIBER.—No such patent was ever obtained. It is the fashion for many makers to advertise their productions as “Patent Machines;” and in this instance it is quite possible that the firm referred to has been working out the patent of another party.

G. B.—An engine of this kind is now being engraved.

A SUBSCRIBER.—We regret the necessity of our stating that there is no special work on this subject. Whatever published matter is in existence, is in a scattered state.

A. C., Oldham.—We believe the work is published by Mr. Bogue of Fleet-street. Our correspondent's bookseller will easily procure it through his agent.

A. K.—We think our correspondent will find what he proposes at page 277, Part LX., of this Journal.

L. G.—We have a large mass of notes to consider yet.

QUEST.—Yes, if you can get a connecting-rod that will always be parallel to itself.

THE NEW YORK EXHIBITION, 1853.

"Every ship that comes to America got its chart from Columbus; every novel is a debtor to Homer; every carpenter who shaves with a fore-plane borrows the genius of a forgotten inventor. Life is girt all round with a zodiac of sciences—the contributions of men who have perished, to add their point of light to our sky."—EMERSON.

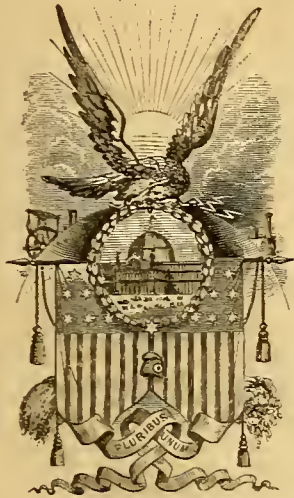

IEWED as an industrial school, the American Exhibition can only now be said to be fairly organized, although its labyrinths of world-wide productions were nominally thrown open so far back as the middle of July, a date, by the way, very far in arrear of that originally promised and intended by the leaders of the enterprise. But it is now needless to discuss the question of such very obvious unpunctuality. The meagre results of the undertaking contrast too strongly with the vastness of the promises prominently held out to us, to render necessary any animadversion on our part. It is perhaps enough to be able to say that the Exhibition has entered upon its practical career, whilst we touch as lightly

as may be upon its defects, and accord an equally fair share of praise to whatever it possesses of meritorious realities.

The Exhibition building stands in Reservoir Square, close to the distracting reservoir of the great Croton Water-works, its ground plan being that of a Greek cross, which is overshadowed by a central dome. The length of each diameter of the cross is 365 feet, and the width of the arms 149 feet. But although the edifice is cruciform, the actual ground plan is octagonal, the angles of the cross being filled up by intermediate stories, 24 feet high. In general appearance, it bears a strong resemblance to our own Hyde Park building, being made up of a system of iron columns, and girders, and glass, the combination of which will be understood from the following description, given in the *Illustrated Record of the Exhibition*, a remarkably well illustrated publication, issued by Messrs. Putnam:—

"The columns divide the interior into two principal avenues or naves, each 41 feet and 5 inches wide, with aisles 54 feet wide upon either side. The intersection of the naves leaves in the centre a free octagonal space 100 feet in diameter. The columns still further subdivide the aisles and the triangular intervals between the arms of the cross, into square and half-square compartments of 27 feet on the side. The aisles are covered with galleries of their own width, and they are united to each other by broad connections at the extremities of the naves. The naves are carried above the roofs of the galleries to admit light, and are spanned by 16 semicircular arches of cast-iron, which are 40 feet and 9 inches in diameter, and placed at a distance of 27 feet from each other.

"The number of cast-iron columns upon the ground floor is 190. They are 21 feet high above the floor, octagonal, and 8 inches in diameter; the thickness of the sides varies from half an inch to one inch. The cast-iron girders, 3 feet wide, of which the longest are 26 feet and 4 inches, and those of wrought-iron, 40 feet and 9 inches long, are indicated by the dotted lines. The first tier of girders sustain the floors of the galleries, and brace the structure in all directions. They are united to the columns by connecting pieces 3 feet 4 inches high, which have the same octagonal shape as the columns, and flanges and lugs to be bolted together. The number of girders in the first tier is 252. The second story contains 148 columns 17 feet and 7 inches high, which rest on those below them, and have the same shape. They receive a second series of girders numbering 160, which support the roofs of the aisles. They also receive the semicircular arches of the naves. All the roofs are supported upon arches or upon girders, by means of wrought-iron inverted trusses, which receive the angle iron purlins of the rafters; the latter are made of strips of wood inclosed between iron sides. The roofs are uniformly constructed of boards, matched together and covered with tin.

No. 69.—Vol. VI.

"The dome, noble and beautiful in its proportions, is the chief architectural feature of the building. Its diameter is 100 feet, and its height to the springing line is nearly 70 feet, and to the crown of the arch 123 feet. It is the largest, as well as almost the only dome hitherto erected in the United States. To our untravelled countrymen it may be an instructive example of the beauty and fine architectural effect of which this structure is capable, although its dimensions are trivial when compared with the majestic domes of the Pantheon or St. Peter's, or those other wonderful erections of classic and mediæval times when architecture was a passion, and united with religious enthusiasm to produce the triumphs of the art. The dome is supported by 24 columns, which rise beyond the second story, and to a height of 62 feet above the principal floor. The system of wrought-iron trusses which connects them together as the top, and is supported by them, forms two concentric polygons, each of 16 sides. They receive a cast-iron bed-plate, to which the cast-iron shoes for the ribs of the dome are bolted. The latter are 32 in number. They are constructed of two curves of double angle-iron, securely connected together by trellis-work. The requisite steadiness is secured by tie-rods, which brace them both vertically and horizontally. At the top, the ribs are bolted to a horizontal ring of wrought and cast-iron, which has a diameter of 20 feet in the clear, and is surmounted by the lantern. As in the other roofs of the building, the dome is cased with match deal and tin sheathing. Light is communicated to the interior through the lantern, and also in part from the sides, which are pierced for thirty-two ornamental windows. These are glazed with stained glass, representing the arms of the Union and of its several States, and form no inconsiderable part of the interior decoration.

"The external walls of the building are constructed of cast-iron framing and panel-work, into which are inserted the sashes of the windows and the louvers for ventilation. The glass is one-eighth of an inch thick, and was manufactured at the Jackson Glass Works, N. Y., and afterwards enamelled by Cooper & Belcher, of Camptown, N. J. The enamel, with which the whole of it is covered, is laid upon the glass with a brush, and after drying, is subjected to the intense heat of a kiln, by which the coating is vitrified, and rendered as durable as the glass itself. It produces an effect similar to that of ground glass, being translucent, but not transparent. The sun's rays, diffused by passing through it, yield an agreeable light, and are deprived of that intensity of heat and glare which belongs to them in this climate. In the absence of a similar precaution in the Crystal Palace of Hyde Park, whose roofs, as well as walls, were inclosed with transparent glass, it was found necessary to cover the interior of the building with canvas, to produce the required shade.

"At each angle of the building there is an octagonal tower, 8 feet in diameter and 76 feet in height. These contain winding stairways, which lead to the galleries and roofs, and are intended for the use of the officers and employees of the Association. Twelve broad staircases, one on either side of each entrance, and four beneath the dome, connect the principal floor with the gallery. The latter are circular in part, and consist of two flights of steps, with two landing-places. The flooring of the galleries is made of closely-matched planks, while those forming the floor of the first story are separated by narrow intervals, in the same manner and for the same purpose as in the London building. Over each of the principal entrance halls, the galleries open upon balconies, which afford ample space for placing flowers, vases, and statues for decoration. Above the balconies, the ends of the naves are adorned with large fan-lights, corresponding to the semicircular arches within. On each side of the entrances there are ticket offices, and adjacent to them rooms are provided for the officers of the Association, telegraph, &c.

"The rapid and unexpected increase of the applications of exhibitors, induced the Association to erect a large addition to the building already described. It consists of two parts, of one and two stories respectively, and occupies the entire space between the main building and the reservoir. Its length is 451 feet and 5 inches, and its extreme width is 75 feet. It is designed for the reception of machinery in motion, the cabinets of mining and mineralogy, and the refreshment rooms, with their necessary offices. The second story, which is nearly 450 feet long, 21 feet wide, and extends the whole length, is entirely devoted to the exhibition of pictures and statuary. It is lighted from a skylight, 419 feet long, and 8 feet and 6 inches wide.

"The colours employed on the exterior and interior are mixed in oil, the base being the white lead manufactured by the Belleville Company. The exterior presents the appearance of a building constructed of a light-coloured bronze, of which all features purely ornamental are of gold.

"The interior has a prevailing tone of buff, or rich cream-colour, which is given to all the cast-iron constructive work. This colour is relieved

by a moderate and judicious use of the three positive colours, red, blue, and yellow, in their several tints of vermilion, garnet, sky blue, and orange (certain parts of the ornamental work being gilt), to accord with the arrangement of colours employed in the decoration of the ceilings. The only exceptions to the use of oil colours are the ceiling of the American lean-to and the dome; these decorations are executed *in tempera* on canvas.

"The effect of the interior of the dome (designed by Sr. Monte Lilla), is particularly splendid. The rays from a golden sun, at the centre, descend between the latticed ribs, and arabesques of white and blue, relieved by silver stars, surround the openings.

"The building is supplied with gas and water in every part. The gas is designed for the use of the police in protecting the property by night, but is so arranged, that should it be deemed expedient to open the building in the evenings, there will be ample light. The water is accessible at numerous points, with conveniences for drinking, and also for the attachment of hose in case of fire.

"The whole quantity of iron employed in the construction amounts to 1,800 tons; of which 300 tons are wrought, and 1,500 tons cast-iron. The quantity of glass is 15,000 panes, or 55,000 square feet. The quantity of wood used amounts to 750,000 feet, board measure.

The total area occupied by the building, amounts to 249,691 square feet, or 5 $\frac{3}{4}$ acres.

In the *official catalogue*, we find the objects to be divided into 31 classes, on a plan very similar to, and evidently based upon that of the Great Exhibition, 1851.

The following are the countries whence the articles so divided are supplied:—1, United States; 2, Great Britain and Ireland; 3, Zollverein and Germany; 4, Belgium; 5, France; 6, Switzerland; 7, Holland; 8, Austria; 9, Italy; 10, British Colonies—British Guiana, Newfoundland, Prince Edward's Island; 11, Sweden and Norway; 12, Mexico; 13, Turkey; 14, Hayti; and each country has its own set of 31 classes, as far as its productions have warranted the classification.

The entire charge of the interior of the building is in the hands of Capt. Dupont and Capt. Davis, of the American Navy, who have made the following executive appointments:—John M. Batchelder, secretary of the superintendents; George W. Matsell, chief of police; Samuel Weber, arrangement of space and classification; Professor B. Silliman, jun., department of mineralogy and chemistry; Joseph E. Holmes, director of machinery; B. P. Johnson, director of agricultural implements; Felix Piatti, director of sculpture; Edward Vincent, director of textile fabrics; G. P. Putnam & Co., publishers of the official catalogue and record—all which seem to have given unmitigated satisfaction to the public.

Of the leading attractions which strike the observer on entering, and taking a sweeping glance, are—the Baron Marochetti's equestrian statue of Washington; Kiss's well-known amazon group, in bronze; Carew's statue of Daniel Webster; Phalon's Cologne fountain; a series of life-boats; Holme's centrifugal fountain; Putnam's printing presses, and a collection of sewing machines; Kinney's statue of Ethan Allen; a palmetto tree in iron; the New York hatter (Genin's) show-case; Levy's marble mantels and baptismal font; Thorswalden's group of Christ and the apostles; and Barlow's planetarium.

In United States, Class 5, "machines for direct use," we find 126 articles entered in the catalogue. In this collection is a very interesting example of a rotatory steam-engine, constructed on the simple plan patented by Mr. J. S. Gwynne; and Messrs. Sloan & Leggett's "Hydrostat," illustrated in our last number. A double-cylinder engine, made at the Lawrence Machine Shop, works the Exhibition machinery; and a 60 horse engine, by Corliss & Nightingale of Providence, Rhode Island, actuates the machinery in the Machine Arcade—both fair specimens of American work. Gwynne's centrifugal pump, to throw 1,000 gallons per minute, is also shown by the Union Power Company of New York. The same section includes a great variety of peculiarly light carriages of all kinds, many of them most elaborately finished. In "machinery and tools for manufacturing purposes," the British visitor cannot but regard with peculiar interest the model of Eli Whitney's cotton gin, patented in 1793, which has performed for the American cotton planters what the combined exertions of our own Arkwright, Crompton, and Watt, have done for the British manufacturers; nor can he fail to be struck with the wonderful development of ingenuity in the great variety of sewing machines which this division presents to us, as the result of a forced direction to mechanical expedients, consequent upon a scarcity of manual labour; indeed, this must be strongly felt on looking over any single department of the American productions. Everywhere we behold the same sign, the course of which we shall endeavour partially to trace in our renewed examinations of this first Transatlantic Congress of Industrial Art.

CORK-CUTTING BY MACHINERY.

The manufacture of corks in any other way than by hand-cutting, has hitherto been a direct failure. The process is, indeed, one of those whose apparent simplicity blinds us to the perception of many difficulties, which show themselves only in the workshop itself. But these difficulties have at length been, in the main, overcome, in the apparatus invented by Mr. R. B. Cousens, of Halliford Street, London, a gentleman who has previously distinguished himself in several other grades of mechanical contrivance. The essential details of Mr. Cousens' machinery are represented in our annexed engravings, as divested of all extraneous fittings.

Fig. 1 is a side elevation, partially in section, of the working mechanism, one-eighth the real size. Fig. 2 is a corresponding end view. A

Fig. 1.

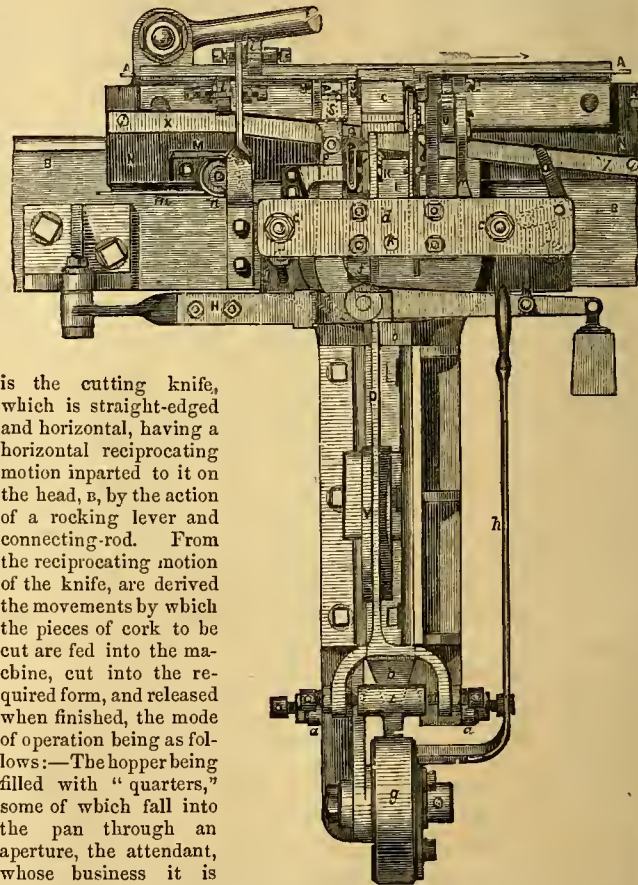

is the cutting knife, which is straight-edged and horizontal, having a horizontal reciprocating motion imparted to it on the head, B, by the action of a rocking lever and connecting-rod. From the reciprocating motion of the knife, are derived the movements by which the pieces of cork to be cut are fed into the machine, cut into the required form, and released when finished, the mode of operation being as follows:—The hopper being filled with "quarters," some of which fall into the pan through an aperture, the attendant, whose business it is to feed the machine, takes a single quarter from the pan with his right hand, and places it upon the brass rest, C, which is screwed to the upper extremity of the feeding-arm, D. The surface on which the cork is placed is inclined at an angle of 45 degrees to the centre line of the feeding-arm, and the back or crest of a cork being placed in the direction of the rest, C, in fig. 2, one of the flat sides rests upon the inclined surface, and the opposite flat side is therefore parallel to the face, E, of the gauging index, F. Should the surface of the cork and that of the gauging index happen to be level with each other, that quarter is correctly gauged, and needs no additional adjustment. If, then, the knife, A, be supposed to be travelling in the direction contrary to that of the arrow in fig. 1, the arm, G, fig. 2, which is attached to the knife-block, and travels with it, strikes the bent lever, H, along with it; and the feeding-arm, D, is then moved into such a position, that the axis of the quarter is in juxtaposition with the axis of the holders, I J. That arm of the bent lever, H, which is in contact with the feeding-arm, D, terminates in a spring; so that, when the feeding-arm is stopped by the stop, K, on the slide-head, L, (which occurs when the knife is within about one inch of the end of its stroke,) the spring will yield to the progress of the knife, and permit the completion of the stroke, so that the cork-holders, I J, may be brought into action. When a cork is cut—that is to say, just prior to the completion of the stroke in

the direction of the arrow, fig. 1—the tappet, *x*, on the knife-block, *x*, strikes the small lever, *o*, thereby lifting the weighted arm of a bell-crank lever, and throwing out the holder-arm, *r*; so that the pall, *q*, catches into one of the ratchet teeth on the slide-head, *l*, and thus causes the holders, *u*, to remain separated for the reception between them of the succeeding quarter. Now, supposing them to be thus separated, and the feeding-arm, with the quarter resting upon its upper extremity, to have

Fig. 2.

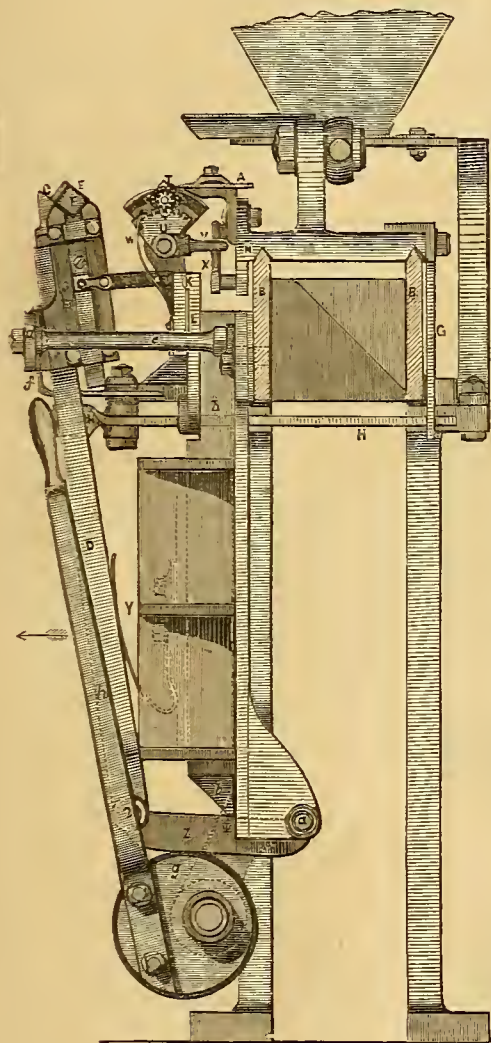

been drawn into its second position by the spring lever, *n*, as above described, the knife performs the remaining one inch of its stroke, and in that space the tappet, *x*, lifts the pall, *q*, by striking the upright arm, *s*, and the weighted lever immediately closes the holders upon the quarter which is thus held at its extremities. The holder, *j*, carried by the lever, *r*, is cupped on its face; so that the end of the quarter is penetrated to a short depth by the projecting ring-shaped edge, the end of the cup being in contact. This holder may be screwed to the end of a short axis or spindle, revolving in suitable bearings, as shown in fig. 1; or it may be firmly fixed to the extremity of the arm, *r*, in which case, the cork, when being cut,

will revolve upon the ring of the cupped face, as any harder substance would upon the centre of an ordinary lathe. The holder, *i*, is the driving holder, and is screwed to the axis of a small pinion, *r*, which pinion is made to revolve by the action of the toothed sector, *u*, which sector performs a partial revolution upon a stud. The sector has a projecting finger, *v*, (fig. 2,) which, by the tension of the spring, *w*, presses upon the upper edge of the inclined bar, *x*, which bar is firmly attached to the knife-block, *x*, and travels with it. The piece of cork having been fed into the machine, and the holders having grasped it at its extremities, the cutting stroke of the knife then commences in the direction of the arrow, allowing the feeding-arm, *d*, to resume its first position, as shown in fig. 2, by the action of the spring, *v*; and the knife having penetrated the cork from end to end, the finger, *v*, at this moment resting upon the inclined bar at *x*, begins to be lifted; so that when the extremity of the incline has arrived at the finger, the pinion, *r*, and with it the driver, *i*, and the cork, will have performed one revolution, and the knife will have cut the cork to the required shape. During the completion of the knife's stroke in the direction of the arrow, the tappet, *x*, separates the holders, and, at the commencement of the return stroke, the friction of the knife upon the surface of the cork forces

it from the driver, *i*, to which it usually clings, and causes it to fall into a receptacle beneath.

In the foregoing description of the general action of the machine, we have supposed the quarter to have been of such a thickness as to require no adjustment of the apparatus to accord with it; but the chief novelty in the invention is, that the contrivance whereby whatever may be the thickness of each succeeding quarter taken from the hopper, the position of the quarter, with reference to the parts of the machine already described, it will be so regulated as to be at once accurately centered and brought within such a distance of the edge of the knife, vertically, that whether it be a large or a small quarter, the largest cork possible, of a circular section, will be produced therefrom, only the same thickness of shaving, measuring on the flat sides, being taken from every sized quarter.

The lower extremity of the feeding-arm, *d*, is attached to one end of the lever, *z*, the other end of that lever having its centre of motion on the back plate, at *a*. The lever, *z*, has resting upon its upper edge the toe of a sliding stem, *b*, which stem carries the slide-head, *l*, and with it the lever, *r*, with the holder, *j*, the sector, *u*, with the finger, *v*, and also the pinion, *r*, and driver, *i*. At *c* are two stays, screwed into the back plate, *b*, for the purpose of supporting the bar, *d*, which bar supports the brass plate, *e*, of the gauging index, *f*, and also the stop and guide, *g*, of the feeding-arm, *d*. The lever, *z*, rests upon the eccentric, *g*, whose centre of motion is on the continuation of the back plate, the eccentric being moved at will by means of the lever, *h*, the handle of which the attendant always retains in the left hand. Now, supposing a quarter to be taken from the pan, and placed upon the brass rest, *c*, in such a position that one of its flat sides is upon the inclined surface of the rest, while the opposite flat side is parallel to the surface, *e*, of the gauging index, *f*, the crust or "back" of the quarter being towards the *c'*, fig. 3; and supposing the upper side of the quarter, when so placed, to stand above the surface, *e*, then it will be seen, that if the lever, *h*, be moved in the direction of the arrow in fig. 2, both the stem, *b*, with its attachments, and the feeding-arm, *n*, with the quarter, will be made to descend through spaces whose relative proportions will be as the distances *a—1* and *a—2*, on the lever, *z*; at the same time, by the descent of the slide-head, *l*, and the carriage of the sector, *u*, and pinion, *r*, motion is communicated to the small lever, *i*, and the gauging index, *f*, is thereby slightly raised; and when the face, *e*, of the gauging index and the corresponding surface of the quarter are thus brought flush with each other, the whole apparatus is in proper adjustment, by reason of the simultaneous movements described, as resulting from the action of the lever, *h*.

The principle of action of these parts of the apparatus will be understood by reference to fig. 3, where *a* is a section of the knife, and *c* is the cork-rest, attached to the feeding-arm. Now, keeping in mind that the knife-edge does not alter its position vertically, and supposing the quarter to be infinitely small, the knife-edge represents every part of that quarter, and the under surface of the knife, and the part, *x*, of the cork-rest, together with the axis of the cork-holders, would be collected together at *s*; but, if a quarter of appreciable dimensions be taken, and we suppose the exact square, *o q r n*, to be the section thereof, it will be seen that, to centre that square upon the holders with such precision as to cut out its inscribed circle, the cork-rest, *c*, must be made to descend through the space, *s r*, the holders must descend through the space, *s t*; and at the same time, the gauging index must ascend through the space, *s q*. Now the side of a square, or the diameter of its inscribed circle, which is the same thing, being to the diagonal as 5 is to the square root of 50—that is to say, very nearly as 5 is to 7—it follows that, if we call *s u = 5*, then *q r = 7*, *u r* and *s q* being each equal to 1; consequently, *s r* (the descent of the cork-rest) will be $5 + 1 = 6$; *s t* (the descent of the holders) will be $\frac{6}{2} = 2.5$; and *s q* (the ascent of the gauging index) will be 1. Therefore, the distances, *a—1* and *a—2*, on the lever, *z*, fig. 2, being as 2.5 to 6, and the arms of the small lever, *i*, being as 2.5 to 1, every quarter, whatever its thickness, will be accurately gauged and centered.

Fig. 2.

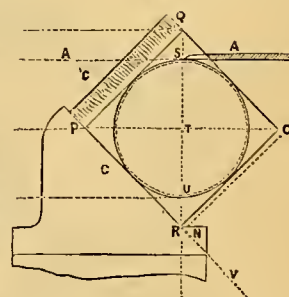

In this description, the section of the quarter has been supposed to be an exact square, and the object has been supposed to be the production of a circular section, whose diameter is precisely equal to the side of the square. But it being necessary, in practice, to cut the shaving of some

slight thickness at the flat sides, o q and r p, to produce that effect, the knife is set down a little in the direction of the centre, t, so that the line of shaving would be represented by the inner dotted circle. Moreover, it being necessary to remove a somewhat greater thickness of shaving from that side of the cork, o r, usually called the "helly," in practice, the rest, c, is set down a little upon the feeding-arm, in the direction of the line, r v; so that the side, o n, will be represented by the dotted line parallel thereto, the back of the cork standing up in excess towards c'.

In the drawings, to which reference has been made, the apparatus is represented in the position requisite for cutting the quarters into cylinders. When it is required to cut a conical instead of the cylindrical form, the set screws, j, are loosened, and the back plate, which hangs upon the pivot, k, is canted, so that the cupped holder, i, is more elevated than the holder, l, their axial line forming an acute angle with the knife-edge. When canted to the required angle, the hack plate is again set fast by means of the screws.

The knife is kept sharp by passing it, every stroke, between two circular stones, l, fig. 1, which are made to revolve in contrary directions, by means of catgut, m, passing to them below the pulley, n.

Machines of this class are now in successful operation in London, their rate of action being 24 revolutions per minute, producing 10 gross, or 1410 corks per hour.

DARLING'S MALLEABLE IRON-WORKS.

The illustration accompanying the present article represents a ground plan of a novel arrangement of wrought-iron works, recently patented by Mr. W. Darling, of Glasgow. The improvements involved in the

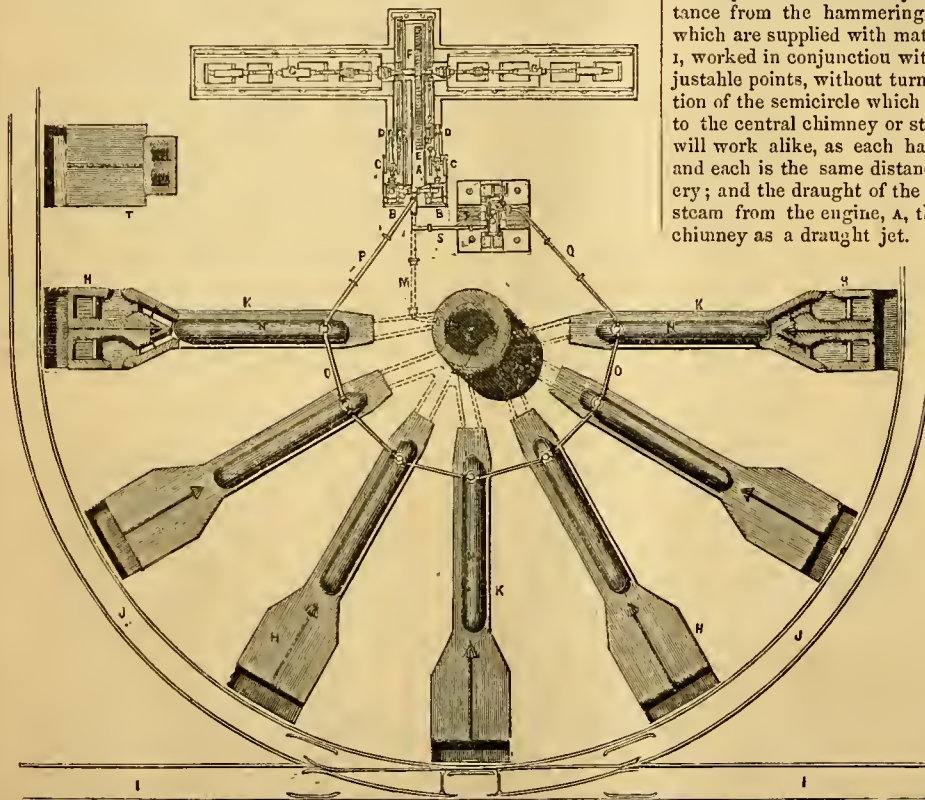

new system refer as well to the mode of actuating the rolls and working mechanism, as to the disposition of the puddling furnaces. Instead of the ordinary gearing, Mr. Darling arranges his machinery so, that the engine or prime mover works at a higher rate than the rolls; so that a small engine may be employed with a steadier and more efficient rolling action than at present, whilst the cost of the machinery is lessened. The furnaces are disposed semicircularly in plan, the flues of the entire series being all made to converge to a single central chimney, in such manner that the smoke ducts shall be of uniform length throughout the set, each furnace thus working alike. And to aid the chimney draught, the waste steam from the engine is conducted into the central stalk, just as is done in locomotives. The common chimney is placed at the centre point,

from which the semicircular plan of the furnaces is struck out; and as the several converging flues pass over the space included by the semicircle, advantage is taken of the heating power of such flues, by placing a set of boilers above them. At present, the puddling or heating furnaces—where open-burning, non-caking coal is used—can only be worked with coal of a large unbroken size; but Mr. Darling makes them capable of working with culm, or small coal, by adopting moveable furnace bars, such as Juckes' or Bodmer's, whereby dross may be effectually consumed.

Our engraving represents a general plan of the works, arranged as a forge, and plate or sheet mill. A is a double engine, the two steam cylinders, B, being laid horizontally side by side, on a cast-iron foundation, C, with their cranks, D, at right angles to each other. The connecting-rods and slide blocks are arranged in the ordinary manner of horizontal direct-action engines, the driving cranks being fast on the opposite ends of the first motion shaft, carrying the fly-wheel and driving pinion, E. The spur pinion, O, gears directly with a large spur wheel, H, fast on a shaft, running in hearings on the foundation plate, and fitted with ratchet couplings on each end, for coupling right and left with the lines of rolls, O. The steam cylinders, B, being of small diameter and stroke, are capable of, and arranged for, being driven at a high speed, so as, in the first place, to insure regularity of movement in themselves, as the prime movers of the machinery; and this advantage is further improved by the reduction of the rate, in communicating it to the rolls by the intermediate gearing. The machinery is thus rendered cheap, light, and easily manageable, whilst any sudden shocks or irregularities in the rolling resistance are very much diminished in passing through the several working details. The puddling and heating furnaces, K—in this instance, fourteen in number—are disposed semicircularly round a central stalk, at a convenient distance from the hammering and rolling machinery. These furnaces, which are supplied with materials by means of the straight line of rails, I, worked in conjunction with the semicircular line, J, by means of adjustable points, without turn-tables, are all worked from the outside portion of the semicircle which they describe, their flues, K, all converging to the central chimney or stalk, L. By this arrangement every furnace will work alike, as each has the self-same extent of draught-passage, and each is the same distance, or nearly so, from the working machinery; and the draught of the whole is aided by bringing the waste or used steam from the engine, A, through the pipe, M, for discharge into the chimney as a draught jet.

The radial or converging flues, K, are also made to economize, or utilize, their otherwise waste heat, by placing steam boilers, N, upon them. The bottoms of these boilers are thus exposed to the direct-carried heat of the flues; and as they are all connected together by a semipolygonal range of pipes, O, and suitable steam chests and stop valves, the whole series is combined to furnish the steam required for the works at a very economical cost, whilst any one boiler may be disconnected from the rest at pleasure. On one side, the range of steam pipes terminates in a line of pipe, P, conveying the steam to the rolling engine; and on the other, it similarly ends in a line of pipe, Q, taking steam to the steam hammer, R. The waste steam from the hammer cylinder is also economized, by conveying it into the engine wastepipe, S, for improving the chimney draught. The puddling or other furnaces, in themselves, may be arranged according to any of the improved modern plans, with the exception, that in localities where open burning, non-caking coal is used as the puddling or heating fuel, the firebars are moveable, instead of being fixed, as at present.

A pair of separate heating furnaces are also shown in the plan at T.

It is undoubted, that the sound practical improvements here developed must materially affect the future construction of wrought-iron works, where opportunities arise for the entire remodelling of existing plans.

M'CONNELL'S EXPRESS LOCOMOTIVE ON THE LONDON AND NORTH-WESTERN RAILWAY.

(Illustrated by Plates 112, 138, and 139.)

We gave the external longitudinal elevation of this engine in our part 57, for December last. We now add two transverse sections to corre-

LONDON &
NORTH WESTERN

EXPRESS
LOCOMOTIVE.

J. E. MC CONNELL.

PATENTEE, WOLVERTON.

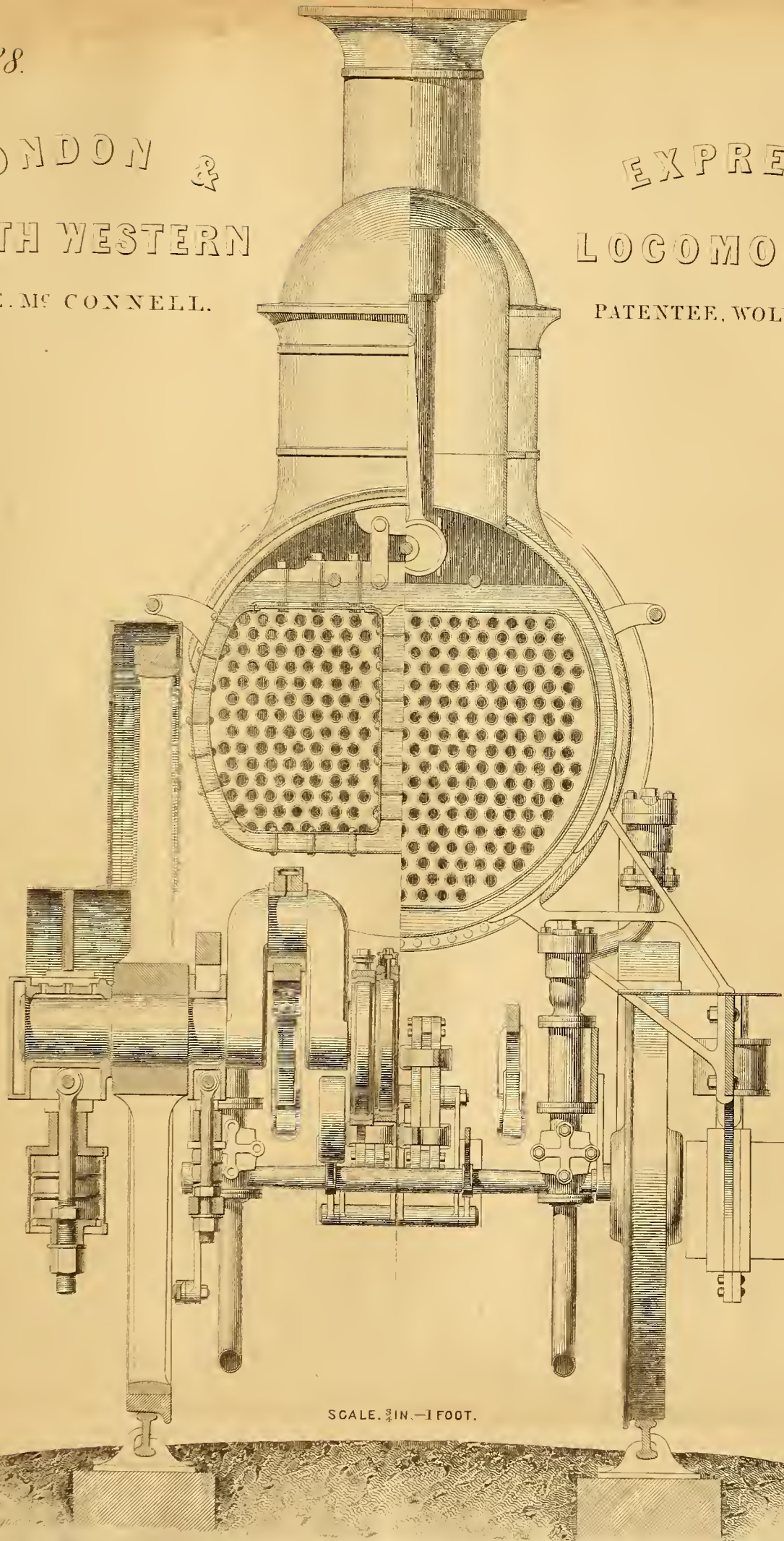

SCALE. $\frac{3}{4}$ IN. = 1 FOOT.

LONDON &
NORTH WESTERN

EXPRESS
LOCOMOTIVE.

J. E. McCONNELL,

PATENTEE, WOLVERTON.

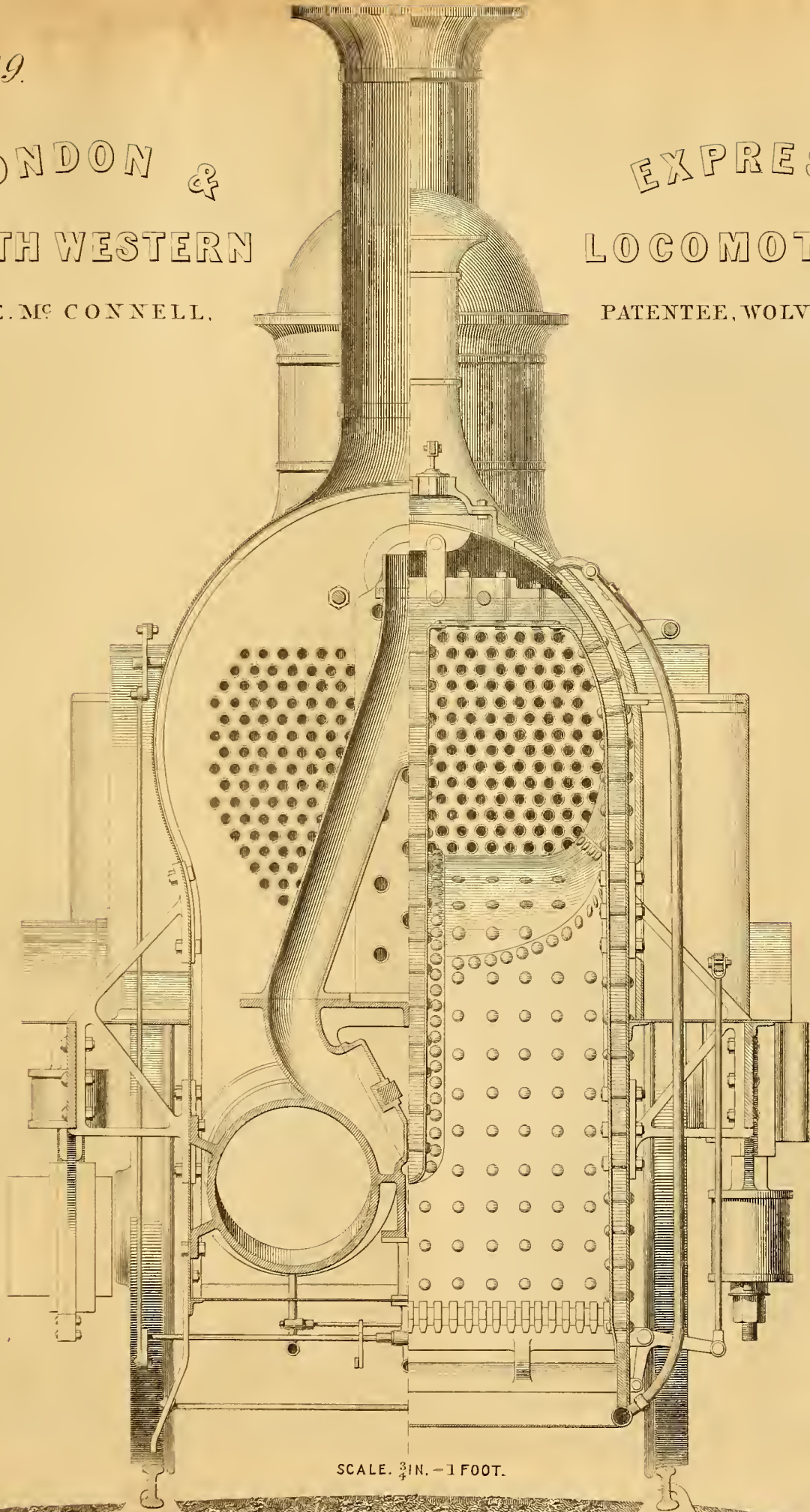

SCALE. $\frac{3}{4}$ IN. - 1 FOOT.

spind; and next month we shall give the longitudinal section to complete the series. Of the two illustrations in the present part, Plate 138 is a transverse section, one half through the barrel of the boiler, at the steam dome, showing the sectional area of the innermost expanded portion of the inside fire-box; the other half section is taken at a point above the crank axle, where the narrow neck of the inside fire-box occurs. Plate 139, also furnishes two distinct half sections; one through the smoke-box, cylinder, and blast pipe; and the other through the fire-box in the line of the safety valve.

WICKERSHAM'S AMERICAN SEWING MACHINE.

This machine, which is the invention of Mr. W. Wickersham of Lowell, State of Massachusetts, and patented in this country by Mr. W. Johnson, C.E., is calculated to sew either a chain stitch with a single thread, or a stitch or plegma formed of two threads, and so that the loops of one of the threads shall alternately pass through or be interlocked with those of the other, as seen in fig. 1; in which A and B may be supposed to represent a section of two layers of cloth to be sewed together; c and d, the two threads. The loops of the thread, c, are seen at e, e, whilst those of the thread, d, are at f, f. In plegma-stitch sewing, as represented in fig. 1, the loops of one thread serve to bind those of the other in the cloth, so as to prevent either thread from being unravelled or drawn out of the cloth. By this improved mode of sewing cloth, or of forming sewing by the inter-looping of two threads, so that the loops shall be entirely on one side of

Fig. 1.



the cloth, the great objection to the ordinary chain stitch, on account of the ease with which it unravels, is overcome.

Fig. 2 of our engravings represents the machine in vertical section; fig. 3 is a second vertical section at right angles to fig. 2; fig. 4 is a view of the under side of the machine, seen as inverted; and fig. 5 is a view to the needle as detached and drawn to a larger scale. The machine consists of a frame or table, A, to which a hollow arm, B, is fixed, and made to extend above and over the upper surface of the table. This arm supports the needle-

Fig. 2.

rod or bar of metal made vertically, and is jointed upper arm of a bent lever, a fulcrum, E. The movement effected by means of a the driving-shaft, G, the a projection upon it, being the cam, which is formed tends down from the lower is formed as represented consists of a hook, H, in there is a small slide, I, down in a groove formed When brought down upon lower end closes the en-

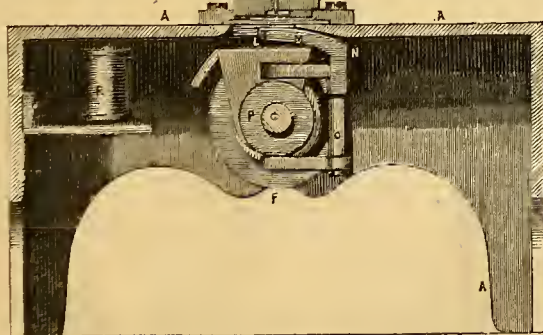

the slide, I, is so moved down on the hook previous to its upward movement through the cloth, the hook is prevented from catching.

In connection with the hook, or needle, two thread-guides, or carriers, L, M, are employed, consisting of curved arms, or thin blades of steel, respectively projecting from two vertical shafts, N, O. An arm extends at right angles from each of the shafts, and carries a small projection or

stud, entered, one above and the other below, into the groove of a cam, P, fixed on the driving-shaft, G. A movement is imparted by the cam, P, to each thread-carrier, causing it at the proper time to lay its thread across the hook of the needle after the latter has been moved down through the cloth.

Fig. 3.

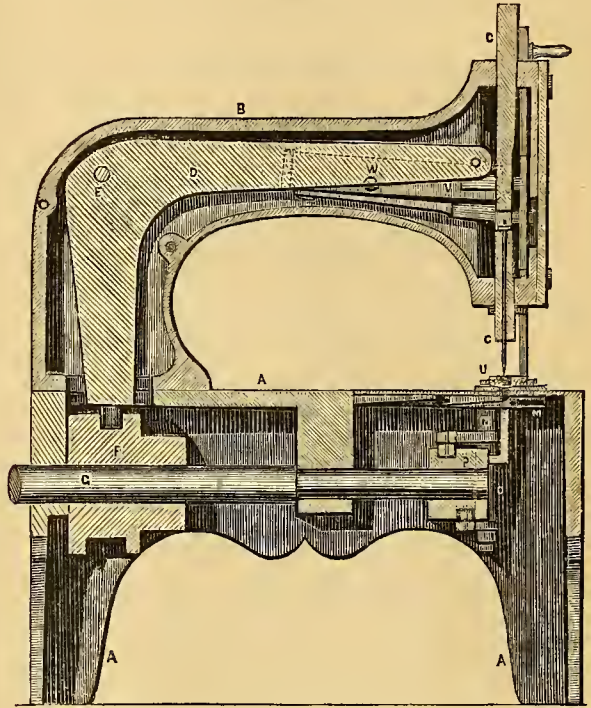

The threads, Q, proceed from bobbins, R, suitably placed. Each thread, before it is passed through the eye or hole of its thread-guide or carrier, is passed through an eye or hole made through one end of a draft-spring, S, the object of the draft-springs being to draw their respective threads into the cloth, and to keep them always straight, so that the thread-carriers may throw the threads into the hook of the needle.

Fig. 4.

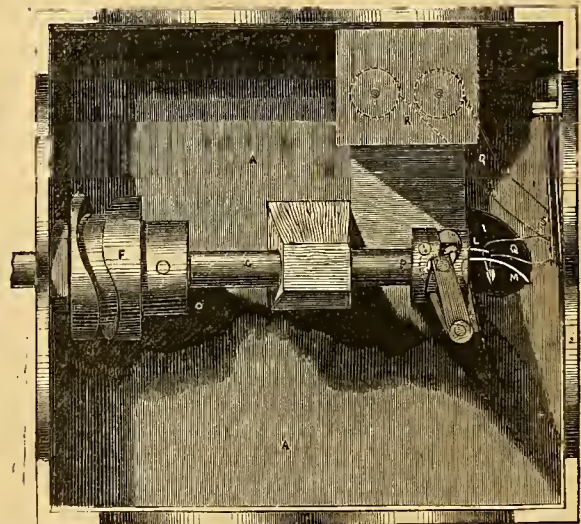

The needle-slide has a small projection, T, extending from the upper part, and lying between two spring-plates, which are made to grasp the projection between them. There is also a small pin passed through the needle-slide somewhat below the projection, T. The pin works within a notch formed in the needle-carrier, the whole being arranged so, that,

during its descent, the needle will pass down entirely through the cloth, and far enough to carry the top of its hook a short distance below the lower edge of the cloth; the spring-plates, however, will grasp the projection, *r*, with sufficient force to prevent the slide from descending with the needle, until the top of the slide abuts against the top of the notch of the needle-carrier. As soon as this takes place, the needle-slide will be moved downwards, and pass through the cloth, but not so far as the top of the hook of the needle. The needle may then be said to be opened, so that a thread may be laid in its hook by one of the thread-guides. The needle is next raised upwards, and will pass upwards independently of the needle-slide, which is, in the meantime, held down by the action of the spring-plates, until the lower end of the slide is met by the ascending hook of the needle, or until the lower side of the notch of the needle-carrier is brought up against the pin in the top of the slide. When this takes place, the needle is closed, so that the hook can pass freely upwards through the cloth and the loop without catching either. The needle-slide afterwards rises upwards with the needle, until the upward movement of the latter ceases. When the downward movement of the needle next takes place, the spring-plates cause its slide to remain stationary until the needle-hook descends away from it, and until the upper part of the notch of the slide strikes against the top of the needle-slide, when the needle-slide will move downwards with the needle as before.

Fig. 5.



The mechanism for feeding the cloth under the needle with an intermittent movement may be thus described:— The cloth rests on the top of the table, and whenever the needle is raised out of the cloth, the latter is moved forwards a distance equal to the length of each stitch, the cloth remaining at rest while the needle is in it. For this purpose, a propeller, *v*, is provided, consisting of a plate of metal made rough, or formed with teeth on its lower side. This rests on the top of the cloth, and partly around the needle. This propeller is at each stitch pushed forward by a wedge-piece, actuated from the bent lever, *d*, by means of the smaller lever, *v*, oscillating on the centre, *w*; after which it is raised by the same lever, *v*. Whilst the propeller is raised, the cloth is held down by another similar but unroughened plate, actualike manner.

During the operation of the machine, the needle is made to pass down through the cloth, having its hook a short distance from the lower end of the needle-slide, which is also carried down through the cloth. One of the thread-guides is next moved so as to carry its thread into the opening of the hook, so that, on the rising of the needle, the thread will be drawn up through the cloth in the form of a loop. The needle next descends through the loop thus formed, the needle-slide remaining stationary until the hook is open, when it descends with the needle as before, and the other thread-guide is in its turn moved so as to lay its thread into the opening of the hook. The needle again rises and forms a new loop, drawing the thread through the cloth and through the loop just previously formed. In this way the sewing operation is performed with two threads, one serving as a binding thread to the other.

GORDON'S IMPROVED CARRIAGE.

In the carriage division of the Dublin Exhibition, a very important improvement, in reference to the fore carriage of four-wheeled vehicles, is brought forward by the Rev. J. F. Gordon of Downpatrick, aided by

Fig. 1.

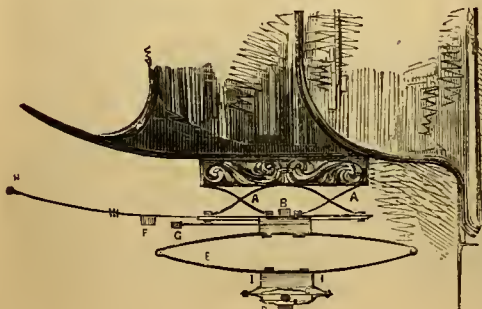

the constructive talent of Mr. R. T. Lithgow, the carriage builder of that town. This improvement is intended to obviate the very usual complaints as to the impracticability of bringing the hind and front wheels of carriages nearer to each other, in consequence of the large circle described by the front wheels and axle in moving from the centre, as well as the want of facility in turning. The peculiarity of Mr. Gordon's modification is, that instead of the front wheels requiring about 40 inches from the centre of the axle to turn, they are en-

abled to turn a full quadrant, and one-eighth of the remainder; and the circle thus described has a radius of only 7 1/2 inches instead of 40, enabling the front and hind wheels to be brought from 28 to 30 inches nearer each other than in the ordinary plan; the carriage being drawn with at least a third greater ease. And when the wheels are turned to the extreme end of the lock or stop, the points of the shoeing in contact with the ground, are in precisely the same position as if going straight forward, so that overturning is impossible. Our engravings exhibit the improvements in three separate details. Fig. 1 is an outline of the body, showing the fore carriage action; fig. 2 is a corresponding plan; and fig. 3 is a plan of the fore and hind axles combined. In fig. 1, *A*, are iron stays, attaching the body to the fore carriage; and *B* is the upper joint corresponding to the joint on the axle; *C* are the jaws of the axle; *D* is a case-hardened bolt, an inch in diameter; upon which bolt the arrangement mainly depends, as the wheel turns at a point immediately at the back of the nave. *E* is the spring, and *F* the front pole socket; *G* is the joint end of the connecting rod which moves the carriage in making its turnings, as represented in

Fig. 2.

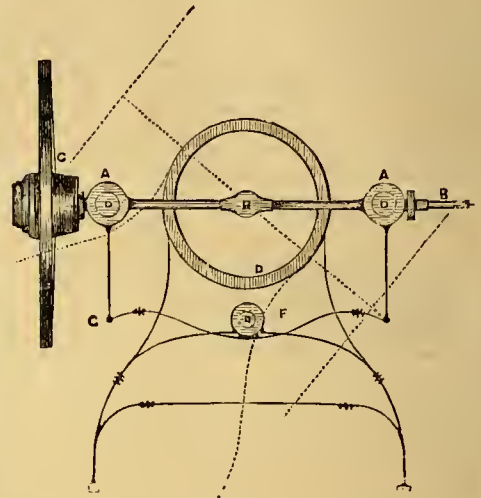

fig. 2; *H* is the end of the futchell, connected to the shaft by a joint; and *I* is a stay, cranked over the axle joint, to which the spring is bolted.

Fig. 3.

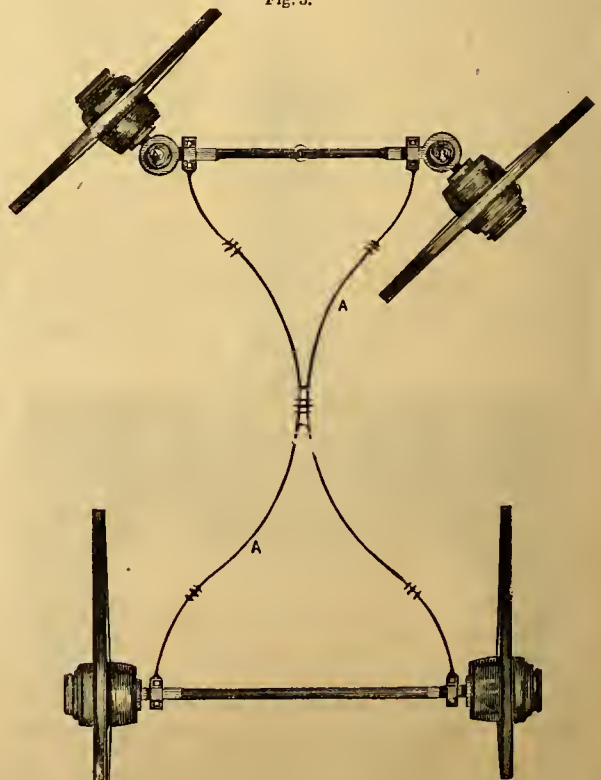

fig. 2; *H* is the end of the futchell, connected to the shaft by a joint; and *I* is a stay, cranked over the axle joint, to which the spring is bolted.

In fig. 2, A are the disc joints at the back of the wheels upon the front axle, and B is the bare axle, a wheel, c, being shown upon the axle on the other side; D is the wheel plate; E are the joint ends of the rod, enabling the front wheel to follow the direction of the horse. The dotted lines indicate the position which the front wheels would occupy, if turning from the centre, as in the common plan. In fig. 3, A is an iron perch, attaching the front and hind axle by bands. The entire fore carriage is of wrought-iron, and the wheel plate, futchells, futchell stays, splinter bar, and front pole socket, are all in one piece. The Exhibition carriage is very creditable to the town of Downpatrick.

the lever punching-press delineated in the annexed diagram being used for the purpose.

The first lever, A, is 6 feet 6 inches long, with its fulcrum 6 inches from one end, so that its leverage is as 12 to 1. The second lever, B, is 12 feet long, with one arm of 2 feet, making 5 to 1. Hence the gain in leverage = $12 \times 5 = 60$ times; so that 1 cwt. on the scale is equal to 3 tons on the punch. The punching weights are hung on the scale-pan, C, and at D is a back balance.

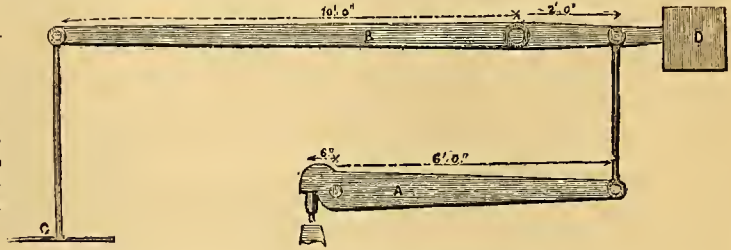

TABLE OF PRESSURES NECESSARY FOR PUNCHING PLATE-IRON OF VARIOUS THICKNESSES.

The following table exhibits the results of a series of experiments made some time ago at the Great Western Steam-Ship Works, Bristol, for the purpose of determining the actual pressure necessary for perforating wrought-iron plates of various strengths. The trials were conducted in the most careful manner by Mr. John Jones, the inventor of the Cambrian engine,

Diam. of Plate.	Thic. of Plate.	Weight in the Scale.		Pressure on the Punch.		Diam. of Plate.	Thic. of Plate.	Weight in the Scale.		Pressure on the Punch.		Diam. of Plate.	Thic. of Plate.	Weight in the scale.		Pressure on the Punch.				
		Cwt.	qrs.	lbs.	Ton.			cwt.	qrs.	lbs.	Ton.			cwt.	qrs.	lbs.	Ton.	cwt.	qrs.	lbs.
16	0	1	17	1/2	1	4	1	14	3	6	0	18	1	1	24	34	7	3	12	
16	0	1	16	3/4	1	3	3	10	4	7	3	12	11	1	0	33	15	0	0	
15	0	2	2	1/2	1	11	0	23	4	11	0	8	11	2	10	34	15	1	12	
15	0	2	1	1	1	10	1	4	4	4	2	16	16	12	2	20	44	8	3	0
15	0	1	26	1/2	1	9	1	9	5	18	3	20	19	17	2	0				
14	0	2	12	1/2	1	16	1	16	6	4	2	6	19	15	3	16	17	11	0	18
14	0	2	8	1/2	1	14	1	4	6	0	0	0	20	3	3	20	18	6	0	18
14	0	2	13	1/2	1	17	1	5	6	1	2	12	21	3	3	0	6	0	6	
13	0	3	5	1/2	2	7	3	12	6	8	0	4	21	0	0	0	9	0	24	27
13	0	3	6	1/2	2	8	0	14	6	7	2	0	23	12	2	0	9	1	11	28
13	0	2	16	1/2	1	18	2	8	8	1	2	17	26	13	2	8	9	1	10	28
13	0	2	14	1/2	1	17	2	0	7	18	0	4	26	16	1	0	12	3	21	38
12	0	2	21	1/2	2	1	2	2	7	18	0	4	26	8	3	0	12	2	8	37
12	0	2	19	1/2	2	0	0	20	8	10	3	16	26	14	3	3	12	1	0	36
12	0	2	20	1/2	2	0	3	26	8	9	1	4	26	11	3	24	14	3	0	45
11	0	2	23	1/2	2	3	1	8	8	7	2	20	31	5	1	7	14	3	0	45
11	0	2	25	1/2	2	3	1	16	9	15	2	9*	31	5	1	7	14	3	6	45
11	0	2	24	1/2	2	3	1	1	4	1	1		12	15	2	4	18	2	11	55
10	0	2	27	1/2	2	4	1	24	7	18	0	19	13	3	0	19	18	2	0	55
10	0	3	0	1/2	2	5	0	0	7	19	0	12	12	18	3	0	18	2	14	55
10	0	2	25	1/2	2	3	2	18	8	0	0	20	21	3	3	0	18	2	0	55
9	0	3	8	1/2	2	9	1	4	9	0	0		21	7	2	0	18	0	0	54
9	0	3	7	1/2	2	8	3	0	9	4	1	4	21	15	0	0	18	0	0	66
9	0	3	8	1/2	2	9	1	19	9	5	1	12	26	12	2	0	1			
8	0	3	26	1/2	2	16	1	20	12	2	2	0	26	8	3	0	7	1	0	21
8	0	3	25	1/2	2	18	1	10	12	0	0	0	26	9	1	4	7	1	5	21
8	0	3	23	1/2	2	17	1	8	12	7	2	0	34	0	3	16	7	0	0	21
8	0	3	24	1/2	2	17	3	12	13	12	2	20*	33	0	0	0	11	0	5	33
7	1	0	1	1/2	3	0	2	19	4	2	5		11	0	0		11	0	0	33
7	1	0	1	1/2	3	0	2	19	5	16	3	4	10	3	21	32	16	1	0	33
7	1	0	2	1/2	3	0	4	23	5	19	0	22	12	0	0	0	10	3	0	32
6	1	0	11	1/2	3	5	3	16	5	17	1	8	13	2	14	40	17	2	0	38
6	1	0	14	1/2	3	7	2	0	7	18	3	10	15	9	2	16	14	0	18	42
5	1	0	26	1/2	3	11	2	22	7	19	3	3	15	9	2	16	15	3	21	47
5	1	1	4	1/2	3	17	1	3	7	16	1	20	23	5	0	0	16	1	16	49
5	1	1	2	1/2	3	16	1	25	11	1	1	0	22	6	1	0	16	0	0	48
4	1	1	1	1/2	3	15	2	4*	3	2	11		22	2	2	0	20	1	14	61
									11	0	2	24	28	2	2	0	20	1	8	60
									12	9	2	16	28	0	3	16	20	0	7	60
									4	0	20	12	28	4	0	12	25	2	25	77

THE LAW AS REGARDS PATENTS FOR INVENTIONS IN THE KINGDOM OF WURTEMBERG.

A royal ordinance, dated the 5th of August, 1836, regulates the law in Wurtemberg, and the effect of it is given in the following paragraphs. The government grants patents for the invention of a new article, a new machine, or a new process of manufacture, as well as to the importer of a new invention from abroad, if such invention is protected by patent in the country from which it is imported. The applicant must give in a statement of his abode, or of the place where he desires to establish the trade or manufacture founded on his invention, and he must set forth

a full description of his invention, accompanied by the drawings, models, or patterns, requisite to the intelligibility of the same, especially describing the particulars wherein the invention differs from others already in use.

The application will be refused, 1, if the invention be in any way discountenanced by the law; 2, if a patent has already been granted for a similar invention; 3, if the invention has already been brought into use in the country. The government will not grant a patent for a longer term than ten years. An exclusive privilege for a longer term can only be obtained by means of a special act of the legislature. When a patent

* Punch broke. † Die and punch broke. ‡ Die broke. § Punch bent and die broke. || A piece of 1/2 bar iron, very soft, and too narrow for a true punch. ¶ Machine would not allow of a stronger piece being punched.

has been obtained, in the first instance, for a shorter term than two years, it may be prolonged to the full term, provided the patentee makes application before the commencement of the last year of the original term, or, in the case of a patent for an imported invention, before the termination of the first half of the original term.

The description of the invention delivered along with the petition, can only be seen by a resident citizen of Wurtemberg, and only when he can show an interest sufficient to entitle him to the inspection, and on his giving security for the non-infringement of the patent during its existence. An inspection will only be permitted after the time allowed for applying for a prolongation has elapsed. All applications for an inspection are advertised before they are granted, in order to give the patentee an opportunity for opposing them.

An annual tax is imposed on patents, varying from five to twenty florins (7s. 4d. to £1. 13s. 4d.), the first instalment being paid on the delivery of the patent, and the others at the commencement of each year of the term.

Patents can be transferred by the patentee to others, or he can allow others to participate in the working and profits. In case of the patentee's death before the expiration of the term, his rights pass to his legal representatives.

A patent for an improvement on an invention already patented, is entirely limited to that improvement, and gives the patentee no rights over the original invention. On the other hand, the improvement comprised in the later patent, is protected as against the original patentee.

An infringement of the patentee's rights, either by directly manufacturing without his consent the objects protected by the patent, or by exposing to sale the results of such manufacture, or by importing similar objects from abroad, will be punished by a forfeiture of the manufactured objects, and payment for all the articles previously disposed of, will be enforced at the selling prices.

A patent will not be granted, or, if granted, will be considered invalid, if, before the deposit of the description, another person has already applied for a patent for the same invention, and has lodged the various requisites previously mentioned; or if the invention has been in public use, either in Wurtemberg or abroad, unprotected by patent, or has been described in some printed publication, or if the description contains any material concealment, or misrepresentation, or if another citizen proves that the invention was originally made by him, and has been improperly appropriated by the patentee or applicant. When the invention has been already made, but kept secret by another person, the patent will be good except as against that person.

A patent will become void if the invention has not been carried into effect, in the country, within two years of the grant, or if a suspension in carrying it into effect has taken place; unless, in either case, sufficient reason can be adduced for not proceeding under the patent. It will also be void, when the exercise of the patented trade is removed to a foreign country, or there is anything contrary to law in the manufacture. A patent for an imported invention will become void, also, if the patent, or one of the patents, protecting the invention abroad, has become invalid at the term of the grant in Wurtemberg.

THE MECHANIC'S LIBRARY.

Architecture of the Farm, Plates 4to., £2 2s., cloth. J. Starforth.
 Engineer's and Mechanic's Pocket Book, 6s. 6d., tuck. Haswell.
 Figure Drawing, Guide to, with Illustrations, crown 8vo., 1s. Hicks.
 Mechanical Drawing, Drawing and Perspective, (Chambers' Educational Course Books 1. to 3.) 1s. 6d.
 Sailing Boat, with Engravings, crown 8vo., 10s. 6d., cloth. H. C. Folkard.
 Sciences, Comtes' Philosophy of, (Bohn's Scientific Library,) 5s. Lewes.
 Stones of Venice, Vol. III., "The Fall," Illustrated, £1 11s. 6d., cloth. J. Ruskin.

RECENT PATENTS.

ROLLING WROUGHT-IRON WHEELS.

W. JOHNSON, *Civil Engineer, London and Glasgow.*—*Patent dated March 22, 1853.*

This is the communicated invention of Mr. J. S. Gwynne, the ingenious American engineer. It relates to a peculiar novel system of rolling and shaping malleable metals, hearing more especially upon the manufacture of wrought-iron railway wheels, wheel tyres, railway bars, cylinder and valve covers, boiler ends or heads, as well as flat plates, discs, and cones. In forming solid railway wheels by this system, a table, revolving horizontally upon a set of conical hearing-rollers, is used, this table having a central recess in it to receive the lower shaping die for one side of the wheel to be rolled. This die surface corresponds in sectional outline with the outline of one side or face of the wheel, and

it has a central pin standing up to form the axle-hole in the wheel boss. It is upon this die that the mass of metal to be rolled is laid, such mass being squeezed on the upper surface, to form the opposite sectional outline of the wheel, by a pair of horizontal rollers set with their axes in one line, but revolving in opposite directions. These rollers are driven from their outside ends furthest from the centre of the apparatus, their inner ends being brought close together at a point coinciding with the centre of motion of the revolving wheel and die apparatus. Thus, to accomplish the required shaping effect, the two rollers of this pair are exact counterparts to each other, and are each shaped so that their longitudinal sections coincide with the sectional contour of the radius of the wheel. In this way, when the apparatus is set in motion, with a mass of iron laid in it, the combined effect of the rollers and die shapes the two sides or faces of the wheel, whilst the tyre or running surface is formed by the circumferential pressure of two or more vertical rollers shaped to the required tyre section. In this way, a finished wheel is rolled at one operation by the combined roller and die actions. By another modification, the circumferential shaping rollers are dispensed with, and the rolling surface of the wheel is shaped by forcing the malleable metal into an annular recess surrounding the table carrying the bottom revol-

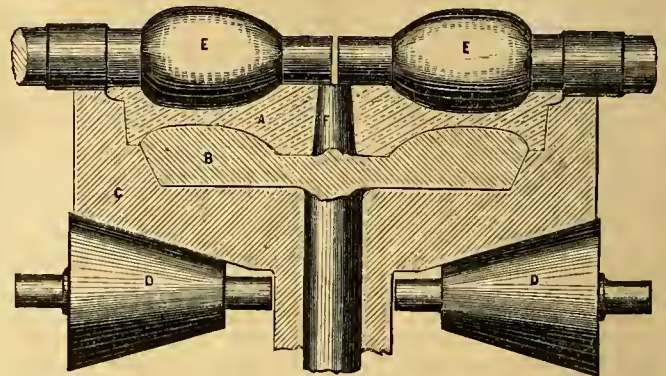

ving die; or no table need be used, if three or more horizontal rollers are suitably disposed above and below the metal to be rolled, such rollers being set to radiate from the wheel's centre, the tyre surface being formed with circumferential rollers as before. All kinds of malleable metal may be manufactured by this system—the dies or rollers being suitably modified for their special purposes; copper still-bottoms, buffer-plates, and tubes may be thus made.

According to the modification represented in the figure, the vertical rollers for shaping the tyre of the wheel, A, are dispensed with, the proper form being given to this part by the table, C, the outer edge of which rises above the die-plate, B, and is moulded to the required contour as at H; and the rollers, E, have shoulders upon them, so as to meet the table, C, at the extreme outer edge of the flange of the wheel.

Several other modifications have been worked out upon the basis of this contrivance, the applications of which are extremely numerous.

"D" FLAX GILL.

W. K. WESTLY, *Leeds.*—*Patent dated March 18, 1853.*

Mr. Westly's "D" Gill derives its name from the figure described by its fallers or combs in their working course. Both sides of the fallers are furnished with combs or gill-teeth, each individual comb on each faller acting alternately upon the material to be treated. The fallers are traversed forward by spiral traversers or screws, in the ordinary manner; but as they each arrive at the end of their forward traverse, they are successively disengaged from their conducting spirals by the descent of a tooth projecting from the interior of a revolving ring, or annular toothed wheel, one such ring being fitted at each end of the line of fallers, just inside the spirals. As the various fallers are in this way successively thrown out of connection with their traversers, they are severally carried back for a new action, by the onward progress of the tooth hereinbefore mentioned, along a semicircular guide, beneath the spirals, when they are again engaged with the fibrous stream and with the spirals. In order to prevent the fallers from being carried entirely round with the revolving rings, a small fixed incline is made to project slightly inside each ring, so that as the fallers are brought against the incline, they are each pushed off the actuating tooth, and left free to be carried in a direct line upon their guide rails, by the spiral traversers. The number of internal teeth in the revolving rings or wheels must

obviously be regulated to suit the pitch and speed of the spirals, so that as each faller arrives at the end of its traverse, it may be duly removed by its allotted tooth. It is thus obvious that the course of the fallers is that of a direct straight line and a semicircle combined, and that the comb which is in action during one traverse along the spirals, goes out

of action during the next traverse, and so on throughout the action. Our illustration represents the invention in detail, as founded upon the "screw-gill," patented in 1833 by Mr. Westly, in conjunction with Mr. Lawson, the machinist of Leeds.

This is a vertical longitudinal section of the working mechanism of the

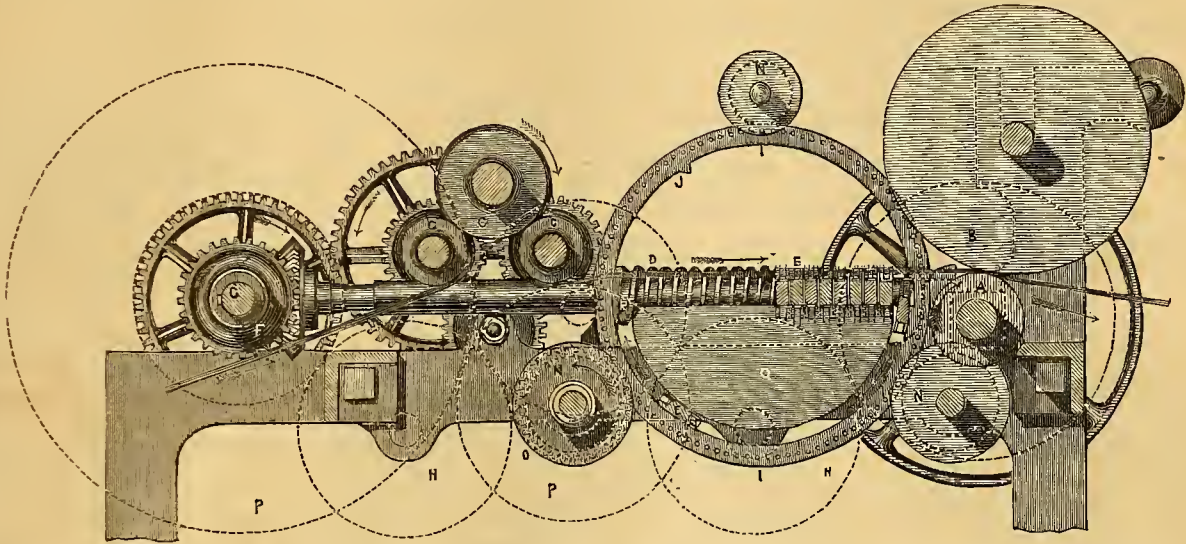

improved gill or drawing frame. The drawing and pressing rollers are at A, B, the rollers, C, behind, being the detaining rollers. The spiral traversers or screws, D, which actuate the gill combs, E, work in end hearings in the side standards of the framing, being actuated by two pairs of bevil-wheels, F, from the cross shaft, G. This cross shaft is driven by the train of spur gearing, H, shown in dotted lines, from the front drawing roller spindle, A, the opposite end of which spindle carries fast and loose driving pulleys, whence the whole of the movements are derived. The duplex arrangement of the comb-bars or fallers, E, is such, that one line of comb-teeth, as shown at E, being on each side of each bar, and each bar being reversed on every traverse, it follows, that the combs act alternately in carrying forward the treated material. The revolving rings, I, are, in this instance, modifications of "mangle wheels," as commonly used in textile machinery, each wheel having internal projections or teeth, J, upon it, for acting at stated periods upon the fallers, E. These wheels are supported and retained in position by the rollers or anti-friction pulleys, K, on each side of the machine. In order to give motion to the ring or mangle wheels, the spur pinion, O, in each case, is keyed fast upon its transverse shaft, which shaft is actuated at the required rate by means of the wheels, P, from the shaft, G. The spur pinion, O, has on each side of it an anti-friction pulley, loose on the shaft, the two pulleys in each arrangement being set to embrace the pinion closely. Although loose on the shafts, these pulleys rotate with the shafts, but at a slightly different velocity, as the diameters of the pulleys are slightly different to the pitch line diameter of their pinion.

Within each of the rings or mangle wheels is fitted a semicircular guide-plate, Q, and the horizontal upper edges of these plates serve as supports for the gills, during their forward traverse, when in real work. At R are fixed inclined stops for entering the gills into the threads of the screws, as the gills commence their forward traverse. The action of this machine is this:—The gills are carried along the upper edges of the guide-plates, Q, in the direction of the arrows, by the spiral traversers or screws, D; but as each successive gill arrives at the termination of its traverse along the upper edges of the guide plates, it is carried down out of the screw threads by the descent of one (on each side) of the projections or teeth, J, in the revolving rings. The gill is then directed into, and carried along between the lower, curved, or semicircular edges of the guide-plates and the interior surfaces of the mangle wheels. When the gill arrives at the beginning of the screws again—that is, at the back of the machine—it is disconnected from the projections, J, by coming in contact with the fixed inclined stops, R, which now force the gill off the acting edges of the teeth, and place it in a position to be carried along by the screws, as before described. The spiral traversers may either be single or multi-threaded screws.

gill, whilst it avoids the essential defects of that arrangement. The cams of the screw-gill require peculiar nicety of adjustment, which, however, is rapidly deranged by wear and tear, and the hammering action upon the fallers. Compared to a given length of screw-gill, the number of fallers in a "D" gill is reduced by one-half, and the number of spirals to one-fourth, and a peculiarly smooth action is secured.

DENTAL INSTRUMENTS.

J. A. YOUNG, Glasgow.—Patent dated April 2, 1852.

The object of this invention, patented and introduced in practice by Mr. J. A. Young, of the firm of A. S. Young and Son, Buchanan Street, Glasgow, is the production of a set of forceps which shall act as efficiently and painlessly as possible; and, for this end, nine forceps are proposed as sufficient for all exigences, the teeth being removed by them

Fig. 1.

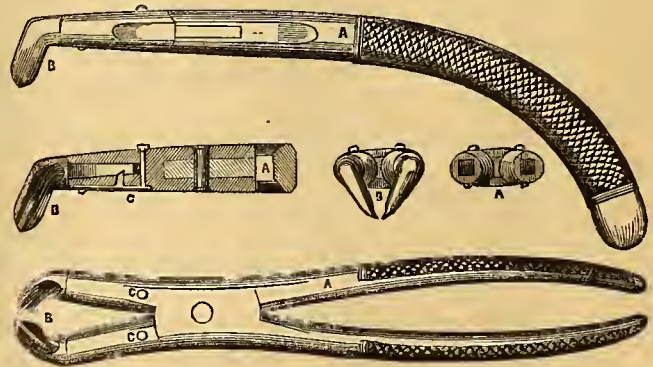

Fig. 2.

rather through insinuation than direct force. In these instruments, the heads of the beaks are opened at an angle sufficient to allow the operator to see the tooth upon which he is engaged. The handles are so curved, and the beaks so inclined to the bodies of the instruments, that they may be freely moved in any direction; and the beaks embrace the roots only, so that as these parts are always more or less wedge-shaped, the forceps act as highly polished inclined planes upon a moveable wedge, often effecting their object by lateral pressure alone.

This very elegant contrivance preserves all the merits of the screw-gill.
No. 69.—Vol. VI.

Fig. 1 of our engravings, is a side view, half-size, of a portable forceps, the beaks, b, being removable from the handles, a. Fig. 2 is a plan of the forceps; and the remaining three details between these two figures, are respectively a longitudinal section of the head and joint, showing the spring catch, c, for the retention of the beak; an end view of the beaks; and the head with the beaks removed.

Fig. 3.

Fig. 4.

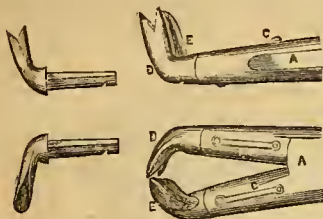

Fig. 5.

Fig. 6.

Fig. 3 is a view of the inside of a beak for the extraction of the upper molars of the right side; and fig. 4 is a similar view of the same part as suited for the left side, the outside of the palatine beak being shown at d, and part of the inside of the outer beak, at e. Fig. 5 is a view of a beak of one of the forceps, the groove in the acting face being highly polished, as a wedge extracting surface. Fig. 6 is a plan of fig. 4.

Fig. 7.

Fig. 8.



Fig. 7 is a plan of both beaks, the same as fig. 5; but arranged immovably, and fig. 8 is a plan of the same arrangement as in fig. 4.

In Mr. Young's portable instruments, any pair of beaks may be adjusted in one pair of handles, so that peculiar portability is secured; for by this means a full set of forceps, with their collateral adjuncts, can be fitted in a small pocket case. The patentee's specification embraces many minor details, which render his nine forceps capable of meeting all emergencies.

A very beautiful set of these instruments, made by Messrs. Hilliard and Chapman of Glasgow, was shown at the Dublin Exhibition; and a still more complete series have been contributed to the Society of Arts Exhibition, for the present season.

LOCOMOTIVE ENGINES.

J. E. M'CONNELL, Wolverton.—Patent dated December 2, 1852.

The first branch of Mr. M'Connell's invention refers to the supplying steam to the burning fuel in locomotive fire-boxes, through tubular stays, as well as to the admission of heated air from the smoke-box into the

Fig. 1.

Fig. 2.

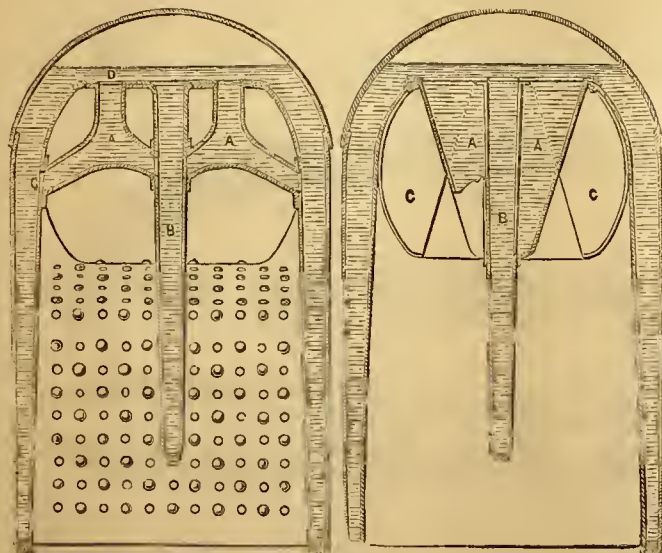

fire-box, or steam and hot air combined. The second portion of the invention comprehends the several forms of fire-boxes shown in figs. 1, 2, and 3 of our engravings. Fig. 1 is a transverse section of an arrangement of fire-box, in which the back, or extended portion of it, is furnished with a series of water passages or ducts, a, which have three openings; one connected with the inside of the mid-feather, b, another with the side of the fire-box at c, and the third opening into the top of the same

at d. By this arrangement, the water has a free circulation, and the globules of steam ascend vertically to the surface. The heating surface is, in this way, materially increased, as the flame and heated air of the fire must necessarily play round or strike against the outsides of the water-ducts, a, on its way to the hoiler tubes. By another modification, the triangular water-spaces, a, may be reversed, with a somewhat similar result, one of the arms or branches, in this case, being vertical. Fig. 2 is another arrangement for effecting the same purpose. A are flat water chambers, riveted to the sides of the mid-feather, b; and c are similar chambers, riveted to the sides of the extended portion of the fire-box, running into the barrel of the boiler. The chambers, a and c, may overlap each other, as shown by the dotted lines, one being placed a short distance behind the other, thereby retarding the heated air in its passage to the tubes. The chambers, a, allow the water and globules of steam to circulate from the top of the fire-box, and the chambers, c, allow the globules of steam to pass from the sides of the boiler to the surface of the water above the fire-hox.

Fig. 3.

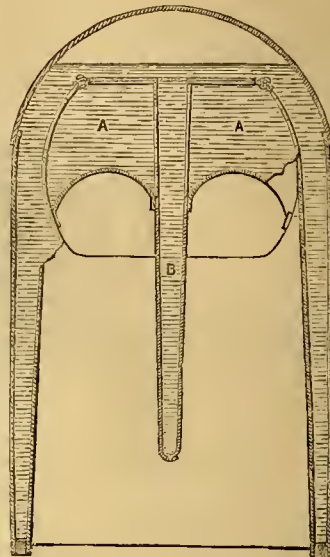

Fig. 3 is a third arrangement, in which flat hollow chambers, a a, are riveted to the top and sides of the fire-box, and sides of the mid-feather, b, and are thus suspended from the roof of the fire-box, partially interrupting the passage of the heated air, the globules of steam ascending to the surface of the water above the fire-box. With these arrangements, coke or any other fuel may be employed in the fire-boxes of locomotive engines, and anthracite coal, which is ordinarily of difficult combustion, may be burned with facility in this way. A further modification is also given, wherein the fire-box has a single central mid-feather, combined with an arched top of the inside fire-box. By this contrivance, stays for the fire-box top are quite unnecessary, as the arched form affords all the strength required, whilst the engine is thus rendered lighter and stronger than common engines. In another plan, three mid-feather water-spaces are similarly arranged in an arched top fire-box, so as to afford increased heating surface. Here the centre mid-feather extends from top to bottom vertically, but the two outside ones are sloped off to avoid the two fire-doors.

ROTATORY STEAM-ENGINE.

R. BARCLAY, Montrose.—Patent dated March 3, 1853.

This engine—which is to be regarded as an important step in the improvement of direct rotatory prime-movers—consists of an external fixed cylinder, set with its axis horizontal, with the main driving-shaft passing through its centre. This cylinder or case contains a smaller hollow piston disc or ring, set eccentrically to the main axis, and well fitted to roll steam-tight round the interior of the outer chamber, the actual line of contact between the two being kept steam-tight, as they work together, by being pressed well into contact by an internal wheel or roller. This roller is carried on the pin of a short crank on the main shaft, the length of this crank being regulated by the diameter of the internal roller, and the thickness of the disc of the rolling piston, round the inside of which the inner roller rolls. A parallel block of metal, of the same width as the revolving ring or piston, is fitted to slide vertically between the two end covers of the fixed cylinder, and has a stuffing-hox to admit of free, but steam-tight, movement. The lower end of this piece of metal, which acts as the steam abutment, rests in a shallow groove in a block fitting to the periphery of the rotatory piston beneath. The steam, or other actuating medium, is supplied by a port on one side of the abutment into the eccentric annular space between the interior of the fixed outer case and the internal rolling disc piston, and the latter is thus compelled to roll round the interior of the outer cylinder, carrying with it its internal roller, which, being attached to the crank, thus communicates a rotatory motion to the main shaft; after performing its work, the waste steam passes off by an outlet on the other side of the abutment. To make the

engine double-acting, so as to get rid of the dead point, a second abutment and set of ports may be added. When the main shaft is made to drive the rest of the parts, the engine becomes a pump or exhausting apparatus.

Fig. 1 is a sectional elevation of the engine, taken transversely through the main shaft, and fig. 2 is an external view at right angles to fig. 1. The steam cylinder, *a*, is cast with, or supported upon, the two vertical pillars or standards, *b*, springing from the base or foundation-plate, *c*, and is bored truly out, and has open ends, covered in by the two end flanges or covers, *d*, bolted on. The main driving-shaft, *e*, passes horizontally through the centre of this cylinder, being carried on each side by bearings in external bracket-pieces, *f*, bolted on to the end covers of the cylinder across the central openings, *g*, in those covers. Outside each

side-wheel, *u*, bears the rotatory pressure in a similar way. The steam, or other actuating medium, is supplied to the engine through a thoroughfare, *e*, which has its opening at *d*, in the base of one of the supporting-pillars, *b*. This thoroughfare conduces the steam into the interior of the slide-valve chest, *e*, through the port, *f*, in the working face of the chest. The slide-valve in this chest is simply employed for reversing the direction of rotation of the engine, or cutting off the steam altogether. It is connected to a spindle, working through a stuffing-box, *h*, in the end of the valve-chest, and is so contrived, that its single cup chamber shall be adjustable to cover up two ports in the valve-chest face. That face has four ports, *i*, *j*, *k*, *l*, in it. The first one, *i*, to the right of fig. 1, communicates, by the dotted thoroughfare, *l*, with the inte-

Fig. 1.

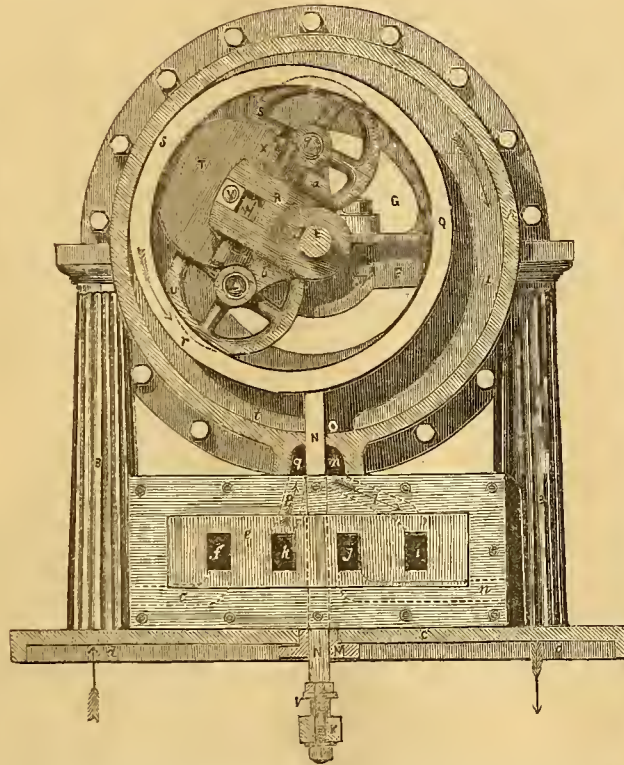
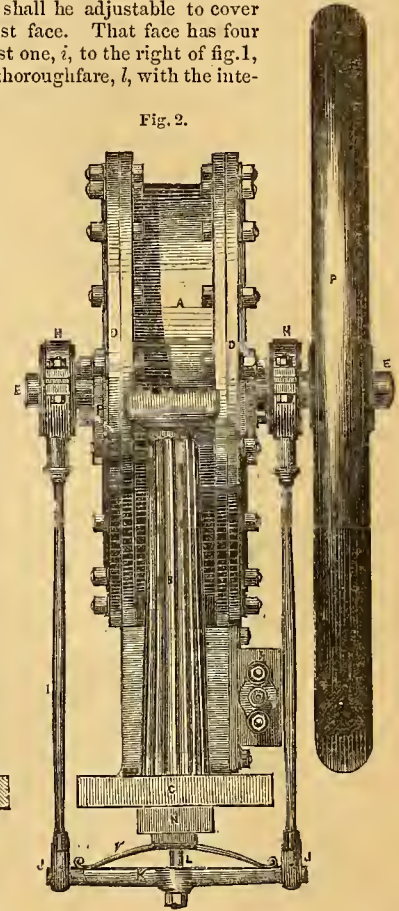

Fig. 2.



cover is an eccentric, *n*, keyed fast on the shaft, and fitted with working rings of brass in the usual manner, rods, *r*, being passed down from each eccentric ring, and jointed, at *s*, to the two opposite ends of a bottom cross-head, *k*. This cross-head is fitted on a turned pin, *l*, formed on the lower end of the abutment, and a spring, *v*, is interposed between the cross-head and the shoulder of the abutment. The diaphragm, or moveable abutment, *n*, works through a vertical steam-tight slot in the cylinder at *o*, having a stuffing-box and gland, *m*, on the underside of the foundation plate. On one side or end, also, of the main shaft, *e*, is the fly-wheel, *p*, for steadying the movement. In the interior of the main working cylinder, *a*, is a smaller open-ended cylinder or ring, *q*, acting as the working piston of the engine. This piston-ring is accurately turned to a cylindrical form both inside and out, and its outer surface is arranged to bear closely on one side, at any given time, against the interior of the stationary cylinder, *a*, with liberty to roll round upon such interior surface, without any sliding or slipping action whatever, and being quite steam-tight throughout its rolling movement, whilst the ends of the ring or piston are made to work equally tight against the interior surfaces of the end covers. As this piston-ring rolls round in its working course, it carries along with it the internal crank lever arm or bracket, *x*, which is keyed fast upon the main shaft, this bracket, *x*, being mounted with three wheels or rollers, *s*, *t*, *u*, to form the connection between the interior of the piston, *q*, and the driving-shaft. The main central roller, *t*, works freely upon a stud-centre, *v*, in a brass accurately fitted into a longitudinal slot in the crank-arm, *x*. The underside of this brass bears upon a layer of india-rubber, or other elastic material or spring, *w*, in the supporting slot, the ordinary wedge-adjustment, *x*, being fitted into the piece, *r*, beneath the elastic bed, for the purpose of setting up the wheel, *t*, with a greater or less elastic pressure, against the interior of the piston. When thus fitted, the wheel, *t*, has a uniformly elastic pressing action upon the interior of the piston, so that the rolling action is extremely smooth, and the contact surfaces are kept well up together throughout the revolution. The object of the two side-wheels, *s* and *u*, which are carried respectively on stud-centres, *x*, *z*, set in the brackets, *a*, *b*, of the crank lever, *x*, is the reception of the pressure of the rolling piston, *q*, and the communication of such pressure to the main shaft, *e*. Thus, in one direction of the engine's revolution, the side-wheel, *s*, receives the actuating pressure of the rolling-piston, *q*, and it is this wheel, at that time, which is, in reality, the means of communication between the rolling-piston and the shaft. Were there no side-wheels, it is obvious that the central wheel, *t*, would furnish the required means of connection, but with the subsidiary wheels, the central one is relieved from this angular strain, and answers simply as the rolling abutment for the steam pressure. On the engine being reversed, the opposite

rior of the working cylinder at *m*, on the corresponding side of the traversing abutment, *n*. The next port, *j*, in the line, opens into the eduction thoroughfare, *n*, for the escape of the waste or used steam down through the base of the left-hand column, *b*, at *o*. The third port, *k*, opens through the passage, *p*, into the steam cylinder, to the left of the traversing abutment, *n*, at *g*; whilst the fourth port, as I have already shown, communicates with the steam-boiler, or other source of power, through the thoroughfare, *e*, the boiler steam-pipe being connected at *d*. According to the indications of the several arrows, the slide-valve is adjusted so that its cup or hollow shall cover over the two right-hand ports, *i*, *j*, whilst the other two, *k* and *l*, are open to the steam supplied to the interior of the valve-chest. The consequence of this arrangement is, that the steam, entering through the port, *f*, from the boiler, descends through the next port, *k*, and passes thence into the working cylinder through the passage, *p*, to the right of the abutment, *n*. Then as the abutment is in close contact at its upper edge with the exterior of the piston, *q*, whilst its two edges work steam-tight against the inner faces of the two end covers of the cylinder, the inflowing steam necessarily acts effectively upon that portion, *r*, of the piston between the abutment face, and the point of rolling contact, *s*, of the exterior of the piston, and the interior of the working cylinder. The consequence of this pressure is, that the piston, *q*, is compelled to roll round the interior of the cylinder, *a*, and thus carry round with it the main shaft, *e*, the piston having no real centre to turn upon itself, but being suspended, as it were, between the prominent portions of the wheels, *s*, *t*, *u*, and the interior of the steam-cylinder. As the piston rolls forward in this way, the eccentrics, *n*, upon the shaft, being so set for the purpose, gradually bear up the abutment to keep its upper edge in contact with the necessary piston surface, until the piston,

having rolled round, again begins to descend, when the eccentrics bring the abutment down, still keeping it in contact with the piston's periphery, until the top of the abutment coincides with the interior of the steam-cylinder, when the piston can roll clear round, or over it, and the revolution is completed. All this time, while the fresh steam is entering and acting in the space, *t*, in the cylinder, the used steam of the previous stroke is escaping from the opposite space, *u*, to the exhaust thoroughfare, *z*, whence it passes through the port, *i*, into the cup of the slide-valve. And as this cup also covers the port, *j*, the exhaust current goes direct to the latter port, and finally emerges at *e*. As the abutment, *x*, rises again at the passage round of the piston, the full pressure steam obviously acts as before in impelling round the piston from the right side of the abutment. But if the reverse motion is required, then the engineer reverses the position of the slide-valve, and covers up in connection with each other, the two central ports, *j*, *k*, whilst the two external ports are left open. In this state of the valve, the influx steam from the boiler, flowing in from the port, *f*, passes down through the first port *i*, and thus enters the steam-cylinder on the reverse, or left side, of the abutment, so as to urge round the piston and its shaft in the opposite direction, the exhaust steam meanwhile flowing off from the right side of the abutment through the passage, *k*, into the cup of the slide, and thence down the port, *j*, to the exhaust discharge, *o*. In this way, the steam is made to act for either direction of revolution with an almost continuous effect, the abutment, *x*, being made to follow exactly the corresponding portion of the periphery of the piston, *q*, at all parts of the revolution; and, to aid in the exact fitting of the abutment, a blade-spring, *v*, is fitted to the cross-head, *x*, so as to afford a means of elastic connection between the abutment and the piston. In the special arrangement which is delineated in the drawings, the packing of the end working surfaces is effected by means of metallic packing rings, one on each side, and each bevelled on the inner side, to correspond to

similar bevelled edges on the piston. The central wheel, *r*, is a double one, or has a deep central groove all round it, so that the other two wheels, *s*, *u*, may work down within it quite freely.

Instead of the arrangement of rolling piston with supporting wheels, as has been hitherto referred to herein, a similar result may be obtained by means of a crank on the shaft only. In this case, the piston must have an actual centre of its own, through which centre the pin of a crank formed in the driving-shaft is made to pass, the radius of the crank being made to correspond with the intended amount of eccentricity of the piston. By this simple modification, the revolving piston may be retained in close rolling contact with the interior of the steam-cylinder, just as already described.

RASPING DYEWOOD.

E. MUCKLOW, *Bury, Lancashire*.—*Patent dated Dec. 28, 1852.*

In the ordinary process of cutting or reducing dyewoods, preparatory to the extraction of the colouring matter therefrom, the solid log is usually pressed forward longitudinally, by means of a rack and pinion, against a series of quickly revolving cutters, or rasps; and as these cutters sever the wood in a downward direction, the consequence is, that the lower edge or portion of the wood is left uncut, and by the continuous motion of the machine is forced downwards until it is dragged off by the friction of the cutting-wheel against the stonework, on which the feed-box of the machine rests, causing considerable loss of power and waste, as these uncut portions or splinters require to be carefully separated from the remainder by hand-sifting. Mr. Mucklow's invention is designed to prevent this waste and loss of time; and it consists in the application of a stationary bar or knife, which is to be placed at an angle of about 45° immediately below the lower edge of the log of dyewood under operation,

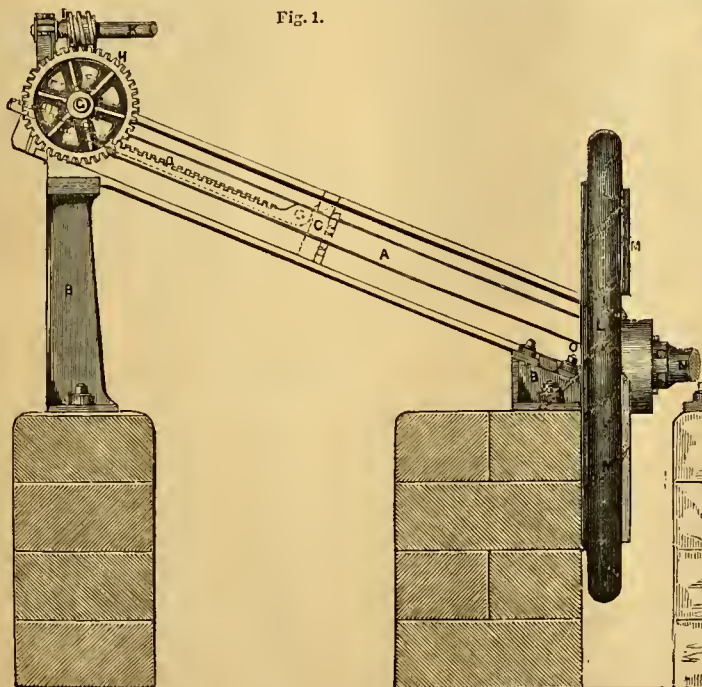

Fig. 1.

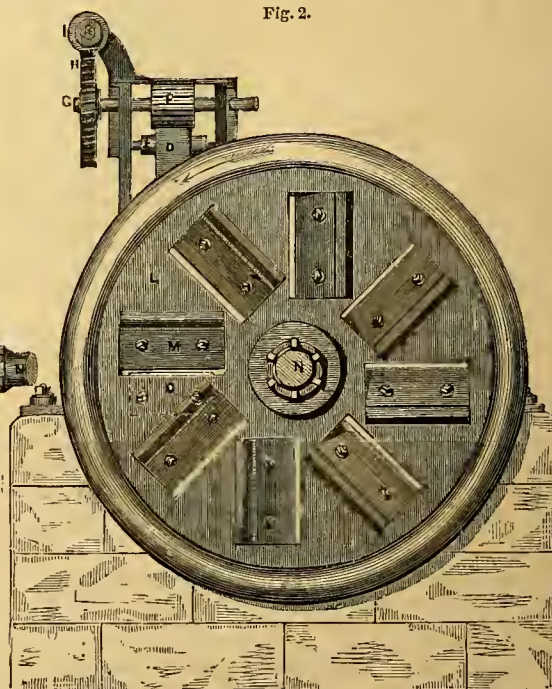

Fig. 2.

and which thus acts as the lower blade of a pair of shears, and so causes the wood to be cut clean through, leaving no uncut portion or splinters.

Fig. 1 represents a side elevation, and fig. 2 is a front view of the machine. At *A* is an inclined trough or box, in which the log of wood to be operated upon is placed. This trough is supported upon suitable framework, *B*, and is furnished with a sliding piston, *e*, which is placed behind the log of dyewood, and is kept steady by means of grooves in the side of the box. The face of the piston is provided with points or spikes, which project into the upper end of the log, thus securing it in its place, and preventing the upper end from rising. The piston is also furnished with a toothed rack, *D*, which moves upon a friction-roller, *R*. The rack is actuated by means of a toothed pinion, *F*, which is mounted upon a transverse shaft, *E*. At one end of the shaft, *E*, a worm-wheel, *H*, is keyed, being driven by means of a worm, *I*, upon the shaft, *K*. The

cutting-wheel, *L*, is furnished with a series of inclined knives, *M*, and is keyed upon a shaft, *N*, which revolves in the direction of the arrow. At *O* is a stationary knife, the upper surface of which is brought to a cutting edge, and projects slightly in front of the trough, *A*, immediately under the extreme edge of the log of dyewood under operation. The action of the apparatus is as follows:—A log of dyewood being laid in the inclined trough, the machinery is set in motion, and the piston descends, and the spikes upon the surface of the latter take firm hold of the upper end of the log. As the piston descends still further, it forces the log forward until the lower end comes in contact with the revolving cutters, which reduce the log to the required disintegrated state, the stationary knife, *O*, causing the wood to be cut clean through, and preventing the lower edge of the same from becoming elipped or splintered off as heretofore, by the downward action of the revolving knives or cutters.

CORRESPONDENCE.

COMBINED GAS AND STEAM BOILER.

The accompanying sketches represent, in fig. 1, a vertical, and, in fig. 2, a horizontal section of a proposed boiler and furnaces, in which all the gaseous products of the combustion of the fuel will be discharged into

Fig. 1.

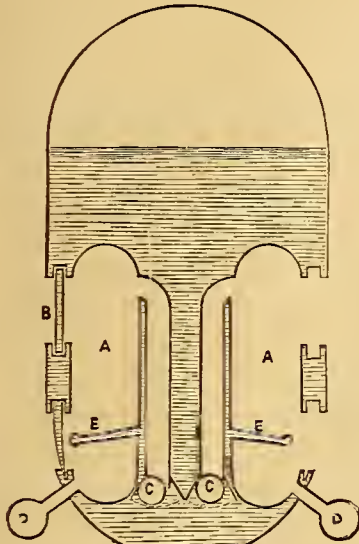
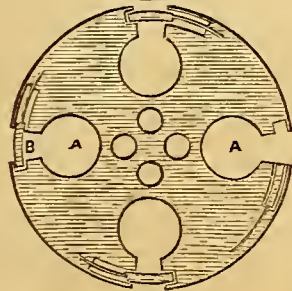

Fig. 2.



the bottom of the boiler, and thence pass, rising through the water—in which all the impurities they may carry from the furnace will be deposited—saturated with steam, through the steam chest into the steam cylinders; the molecules of the gases serving as the convectors of the caloric into the water, instead of radiating it, as at present, through the plates and tubes of the boiler. The advantages attributed to this are, economy of fuel, resulting in two ways—namely, in an absolutely greater quantity of caloric being generated from a given quantity of fuel, and in the saving of that portion of it which at present passes up the funnel in combination with the gases, both in the latent and sensible form. A saving in the cost of the apparatus, due to a reduction of weight and size, and increased durability. The size will be diminished from the smaller quantity of coal to be burnt, and from the greater rapidity of its combustion. The durability will be much increased, as no part of the boiler is exposed to the direct action of the furnaces. And as probably nine-tenths of the whole of the elastic bodies which pass through the cylinders will be steam, condensation will still be applicable, with advantage, under the condition of using a larger air-

pump than is necessary at present.

A careful analytical investigation which I have made, and which has been printed as an Appendix to Mr. A. Gordon's Tract on the Fumifer Propeller, gives 2·630·767 lbs., raised one foot, as the measure of the elastic force of the gases into which 1 lb. of anthracite coal is decomposed by combustion—after deducting the equivalent of the air pumped in to sustain that combustion—on the assumption that the whole caloric developed by the combustion is retained by the gases. Now, although by far the larger part of the caloric will be expended in the generation of steam—the gases simply conveying it into the water—still, since the volume of these gases is more than three times that of the air which is necessary for their generation, under the same temperature and pressure, and all the caloric developed must be either retained by the gases, or taken up by the water, in either case contributing to the total elastic force generated and utilized, a considerable increase of power over that now realized may confidently be expected. The stoke pipes of the furnaces, A, are each intersected by a sliding water-filled door, B, communicating with the boiler by two small pipes, working in stuffing-boxes. These doors will be so fitted to the chamber in which they slide, as to prevent the escape of any of the gases from the furnace into the air. In fact, the greater the excess of the gaseous pressure in the furnace over that of the atmosphere without, the more tightly will the sliding-door be jammed against the part of the boiler on which it rests. Each of the furnaces is capable of being stoked separately and independently of the others; and during this operation, combustion in that furnace will be suspended by the supply of oxygen being cut off, whilst the other furnaces continue in full operation. In the engravings, one

furnace is represented as opened for the purpose of stoking, the floating ball-valve, C, closing the gas-pipe; and the supply of air is cut off by closing the small pipe which connects the circular air-pipe, D, feeding all the furnaces, with the furnace which is being stoked.

H. M. LEFROY,

Naval Instructor, H.M.S. *Impregnable*.

London, 1853.

PARSEY'S SCIENCE OF VISION, OR NATURAL PERSPECTIVE.

As a reply to your review of my work on perspective, in the *Practical Mechanic's Journal* for October, I have to offer the following remarks, at the same time requesting the attention of your readers to the illustrated definition of perspective, given in your *Journal* for July, at page 95.

In the first place, you give unqualified commendation to Mr. Abbott's work on the authority of his title page, stating that "the matter is divested of all difficulty," maintaining, from custom only, "that perspectives should always be made on a vertical plane," which is certainly not a valid reason.

If my book had been "attentively consulted," it would have been seen that I have therein fully elucidated this material question, and, on the optical principles of the art, demonstrated the problem by pure mathematics. Besides, the investigation of the Manchester Architectural Society, reviews, and the testimonies of Royal Academicians, the testimonial of the Rev. J. B. Reade, nephew of Professor Farish, author of *Isometrical Projection*, says—"I have much pleasure in bearing testimony to the value of your work on the Science of Perspective. The substitution of the lateral view, for the vanishing points of the old system, is as new as it is valuable. And the substitution of the right plane for the vertical plane of the old system, has so many advantages, that you may safely calculate upon its universal adoption by the draughtsmen of a future generation. That the present is a prejudiced race, appears from this—that while they constantly converge parallel horizontal lines, they cannot tolerate the convergence of parallel perpendiculars. You will do them good service by teaching them the use of their eyes."—8th Oct., 1836.

The "common rule" of all the authors of representing objects upon a supposed vertical plane, has been the cause of all the difficulty and impracticability of this theory; and, with all books founded on that restriction, draughtsmen must, as you say, "be content to rely on their own ocular impressions, to make the drawing on the paper look something like the object it is intended to represent in nature or art."

I am inaccurately represented as supposing the plane of the visible picture to be not vertical. On reference to my work it will be found that I do not suppose or assume anything, but give physical reasons for my rules, and demonstrate them by pure mathematics. Misrepresentation is not fair nor just criticism, and is alike injurious to the author as it is detrimental to the advancement of practical skill and knowledge. The delusive illustration of looking through a pane of glass, to which I am so kindly advised to resort, will be found to be fully exposed in the 78th page of my book. And if the reviewer will place his eye level with the lowest horizontal bar of a lofty window, he will arrive at the result, that as the upper part of the window is farther from his eye than the lower part, the sides of the window will converge, and all the vertical lines seen through it will correspondingly converge to a vertical axial line in the centre; just the same, and on the same pure mathematical principles that are recognized in horizontal lines with the same adjustment. What there is difficult to comprehend in this, I cannot conceive, or why similar causes of foreshortening and convergence from obliquity of position, of horizontal and vertical surfaces, should not be treated upon the same pure principles of optics and mathematics.

When illustrating the subject before the mathematical section of the British Association for the Advancement of Science, Professor Forbes put a stop to any quibbling discussion, by rising and saying—"he felt sure that every one who had heard Mr. Parsey must have thoroughly understood him, and every one must be perfectly satisfied of the truth of his principles."

With respect to Daguerreotype pictures, or sun-drawings, I challenge any authority to prove them to be otherwise than correct and accurate, according to the optical principles of the human eye, representing things as we see them, unless the true effect is destroyed by the mal-adjustment of the lenses of the camera, for which opticians are employed, as the observed natural convergence is not understood. Arago said, sun-drawings "show how far the pencil of the draughtsman has been from the truth."

As in the denunciation of my theory of the iris being the organic seat of vision, the learned commentator disclaims being a physiologist, it would have been as well if he had let the question alone, as he shows a want of knowledge of the anatomy as well as physiology of the eye, because he says "the retina is black." I never saw a black retina!

He says—"We always understood the seat of vision was in the brain. The brain, or something in it, is the seat to which all the impressions of all the senses are transmitted, through the channel of the nerves. My eye receives an impression on looking at an object—that figured impression on the organs of vision is transmitted; and it is that defined impression which it is my business, as a rational man and an artist, to copy on paper as accurately as the faculty transmits it to my brain.

As for coloured images—if I could put a retina under a hyaloid membrane, and a choroid coat under the retina and *pigmentum nigrum*, with such a camera I could show my friend a coloured image, as I can do with an eye, which I cannot make.

As Euclid's elements are tersely referred to, it may be instructive, as well as amusing, to inform the untutored, that Euclid established his pure mathematical elements on optical observation, and thereby defined the angles and distances by which he could restore the landmarks, when washed away by the overflowing of the Nile, and prevent any dispute. From the same optical source he defines the square or rectangular surface, the trapezoid, and the trapezium. Thus the eye is equally distant from the four corners of the square, and all the angles are alike, isosceles, when the eye is opposite to the centre, and it then appears a square. When the eye is placed opposite the centre of a side, two isosceles angles, of unequal heights, and two obtuse angles are formed, and the square base appears a trapezoid. When the eye is placed so that the distances from the four corners of the square are unequal, and all the angles are oblique, but unequal, then it appears a trapezium. Study mathematics and perspective by this standard, and there can be no difficulty or difference of opinion.

Foreshortening of length, as well as the convergence of the breadth of vertical surfaces, has only been admitted into the common theory of perspective, as regards a horizontal direction, although these effects are always seen under an oblique angular view—and true Euclidian mathematicians demonstrate that with the same data, the geometrical direction of the originating surface cannot diversify the optical configuration. The grounds on which I maintain that I am right, and that other authors are wrong, are, that besides their theory being contrary to the pure principles of optics and the physiology of vision, the restriction of representation to one plane is an incomplete mathematical system, and must remain so until the practical rules which I have given for every conceivable mechanical section are recognised and adopted. My imputation against all authors on perspective is—not that they are wrong mathematically in their own abstract case, but that they are wrong in not making it, according to the meaning of the term, an optical or visual art, and, as a mathematical manual, being incomplete and impractical for the general purposes of art and science.

3 Crescent-Place, Burton Crescent, October, 1853.

ARTHUR PARSEY.

[If it were our practice, as reviewers, to take for granted what authors say in their title pages, Mr. Parsey would have met with a very different treatment at our hands, and we regret that his experience of this has proved so unpleasant to him. We have looked through our review in vain for the assertion that "perspectives should always be made on a vertical plane, giving custom as a valid reason." We merely said it seemed the most convenient, whilst we stated that correct perspectives could be drawn on any plane. The purely mathematical deductions in Mr. Parsey's book are correct; but we repeat that this is not the question. What we seek for in vain in the treatise is, a valid reason for equalizing the extreme rays of the picture object, when the corresponding rays from the original object are not equal. Why should not the plane be always vertical? Mr. Parsey may deem it a refinement to have the plane of the picture always perpendicular to the axis of the eye; but he does not demonstrate the impossibility of drawing in correct perspective on a vertical or any other plane. We said that Mr. Parsey supposed the plane to be not vertical, because he starts by making it not vertical without a valid reason, and proceeds to argue the question of convergent verticals on the grounds we cannot grant. Our author's chief mistake seems to lie in his misconception of the business of an artist, which he says "is to copy on paper, as accurately as the faculty transmits it to the brain, the impression figured upon the organs of vision." Let Mr. Parsey see if this agrees with the definition of a picture given at the commencement of the second paragraph of the review; or let him point out where that definition is incorrect. A true picture is not necessarily the actual appearance of an object as perceived by the eye; it is something contrived to give the same appearance to the eye as the object it represents. The appearance to the eye is different from the object itself. If, then, we make the picture an "accurate copy" of that appearance, such picture will present to the eye a third appearance different from itself—that is, from the appearance of the object it is intended to represent—and it will consequently

be an incorrect representation. Thus, in the experiment of looking through the vertical window, the sides of the window will converge, or, more correctly, will appear to converge precisely as described; but the sides of a vertical drawing, though actually parallel, would also appear to converge under similar circumstances; so that if they and the verticals drawn within them were made actually convergent, they would appear more convergent than drawn, and therefore too convergent.

We do not profess to account for the favourable opinion of Mr. Parsey's system, held by Professor Forbes and others, though the actual point on which the question turns might be very easily overlooked, in so plausible an argumentative scheme, by those who did not thoroughly investigate the subject. Very little is gained by calling in the assistance of the Rev. J. B. Reade, who says that, "whilst the present prejudiced race constantly converge parallel horizontal lines, they cannot tolerate the convergence of parallel perpendiculars." They would err in tolerating converging perpendiculars, or rather verticals, because these are originally parallel to the plane, as are also parallel horizontals sometimes, in which case the latter, likewise, should not converge in the picture. Besides, the grand fundamental principle, that the more distant objects or spaces appear less, is not lost sight of; for the parallel verticals of the vertical picture seem to become convergent, in travelling to the eye, in exactly the same proportion as the vertical lines of the original object similarly become convergent in appearance. Mr. Parsey complains of two defects in the ordinary system; the plane is not situated as it ought to be with regard to the eye, and the verticals are not made to converge; but does not one of these peculiarities neutralize the other—does not the position of the plane make the verticals appear to converge?

With regard to Daguerreotype pictures, opticians need not seek to alter the lenses for the correction of the convergent lines—for this may be done by slightly altering the position of the recipient plate. The convergence, or otherwise, of the lines, depends upon the position of the plate in relation to the lines upon the original object. If viewed from a proper point, all the Daguerreotype pictures with convergent lines would appear correct; and we suspect that all pictures drawn on Mr. Parsey's principles would require to have cyclo-pieces fixed in front of them, to confine the eye to the exact point from which the picture should be viewed, as in the case of the distorted pictures described in the "Boy's Own Book."

The retina, though not black itself, has the *pigmentum nigrum* immediately behind it—still that would not affect its reflecting capabilities; but we think there are several difficulties in the way of Mr. Parsey's theory; we have been told that it was found by experiment, that a very bright light indeed scarcely produced any luminous image on the retina of an eye in its natural state.—THE REVIEWER.]

FEED APPARATUS FOR STEAM BOILERS.

Having seen, in the *Practical Mechanic's Journal*, of last month, an apparatus for feeding boilers under pressure, without pumping, or the use of overhead cisterns, I beg permission to offer a few remarks on that apparatus, referring as well to a contrivance which we have adopted here for a like purpose.

Mr. Huck informs us that he requires no pumping, nor any overhead cistern; but he must certainly have some means of supplying the water to the chamber, if the source is a well, as is usual. And I am inclined to think that, if he has no overhead cistern, he has a cistern, the bottom of which is on a level with the inlet-pipe of the feed-chamber. Our apparatus can be worked without such a cistern, but it is better to have one, or a few feet of fall. In my diagram, A is the steam boiler, above which is a separate chamber, B; a feed-pipe, C, being fitted up to connect the boiler and receiver. This feed-pipe has a valve at D, opening into the boiler; or instead thereof, a cock, E. When the chamber, B, is filled with steam, which is afterwards condensed, a vacuum will, of course, be formed in it, if all the joints are tight. Then, on opening the cock, F, in a pipe leading from the chamber, B, to the well, the chamber will become filled with water. The cock, F, is then to be closed, and E and G opened, when, owing to the balance of the internal pressure, the water in the chamber, B, will find its way down the pipe, C, into the boiler. We find this contrivance to work very well; but it is more particularly adapted for boilers which are not employed in working steam-engines.

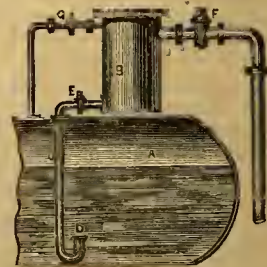

JAMES WILLOUGHBY.

Central Foundry, Plymouth, October, 1853.

PEDO-MOTIVE CARRIAGE.

This velocipede has been specially designed to secure extreme lightness and speed of travelling. Fig. 1 is a side view of the carriage, and fig. 2 is a plan; fig. 3 is a detail of the chain connecting-rod action; and

Fig. 1.

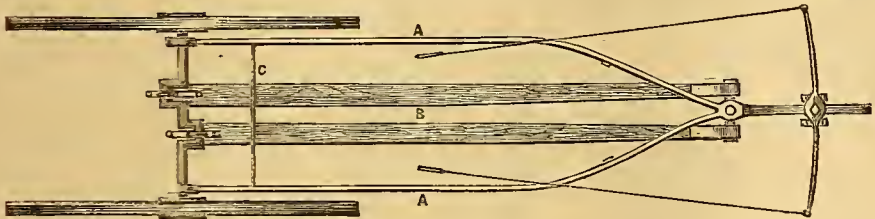
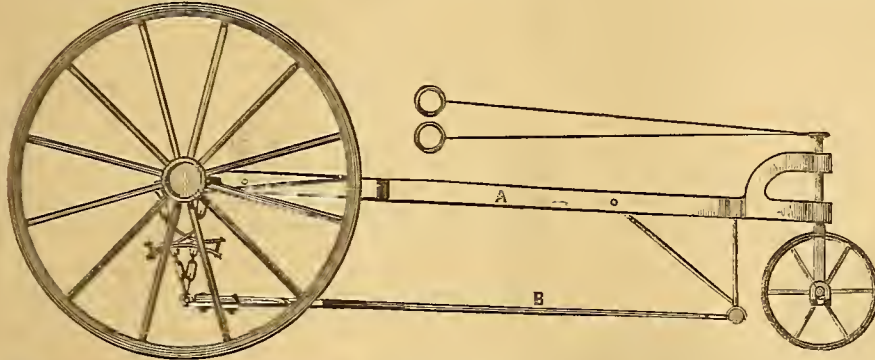

Fig. 2.

fig. 4 is a separate view of the crank-shaft bearings. It is composed of a light wrought-iron frame, A, supported on two hind driving wheels and a single front running wheel. The driving wheels are fast upon their double crank-axle; and motion is communicated to them by the pair of foot-boards, B, which are of lancewood, and spring about three-fourths of an inch under the weight of a man at the point of action.

Fig. 3.

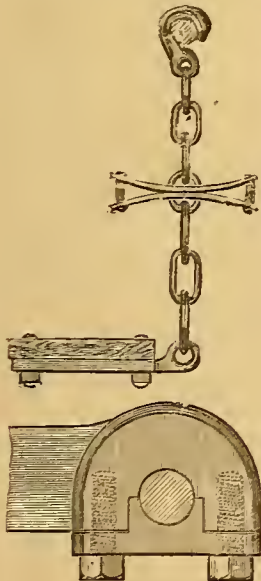

Fig. 4.

The place of a connecting-rod is supplied by a chain, having at its centre a species of double spring-link. The traveller is thus buoyantly sustained, and is comparatively unaffected by the roughness of the roads. The light front wheel is embraced by a forked arm, the spindle of which turns round in two guides overhead; and the spindle carries a cross-piece, from the ends of which two cords proceed to the hands of the passenger, for guiding purposes. In wet weather, a thin sheet-iron splasher can be readily adapted to the large pair of wheels, and temporarily holted to the inside of the frame. The cross stay, c, can be easily formed into a seat; but the weight of the body affords the best effect, when accompanied by the least muscular exertion. The radius of the cranks being 3 inches, and the large wheels 5 feet diameter, I think fourteen miles an hour might be easily attained by this machine on a level road.

call your attention to the fact, that Mr. Brown's hammer is no new invention, as it comes under the claim of my patent steam hammer of 1846. Having learned that Mr. Brown was making a model steam hammer, which, from the description given me, I at once concluded came under my patent, I wrote him a friendly letter, on the 21st February, 1852, describing my claim, and stating that I would protect my patent right, as I had already done with a similar steam hammer, patented in 1847, by Mr. Wilson, the talented engineer of the Lowmoor Iron Company. The claim of my patent covers every variety of steam hammer where the piston, or pistons, are fixtures, with the steam introduced into the hammer or cylinder. And although I have only adopted one form out of the various arrangements at my command, and from the success of the form of hammer I manufacture here, I have no inducement to adopt any other arrangement.

I trust these remarks, written with the best feeling towards you and your able *Journal*, will meet with the attention which the subject deserves; as I feel that I have merely to call your attention to the facts already stated, to receive that justice which I claim as my due.

JOHN CONDIE.

Govan Iron Works,
Glasgow, October, 1853.

CARRIAGE-SPRING PROTECTORS.

The following proposal is made with a view to prevent too great a load injuring the springs of a vehicle, and also to protect them from too heavy a shock. I propose to use a curved surface on each side of the springs, instead of the stop commonly used, so that the shock or

load, when too heavy, may be transferred from the ends of the springs nearer to the axle, thus reducing the leverage, and consequently the strain. The superiority of the curved surface over the stop is proved by the fact, that when once the load or shock is sufficient to force the stop into contact with the spring, the functions of the spring are superseded altogether; whereas the curved surface is only forced so far into contact with the spring as to establish an equilibrium, with the advantage of doing so gradually.

Fig. 1 represents this principle applied to a truck, where the proposed curved protecting surface is represented by the dotted lines attached to the under side of the framing. Fig. 2 represents it applied to elliptic springs. It is here suspended from the ends at an equal distance from the upper and lower springs.

Fig. 1.

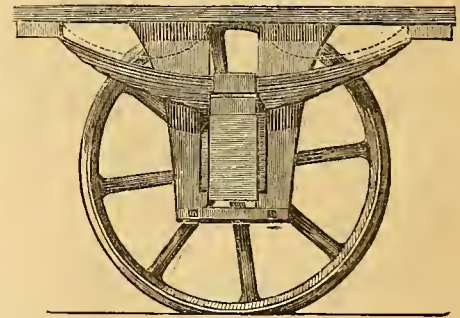

Fig. 2.



Of course the curve may be varied, to come in contact with the spring at any part required, according to the intended use of the vehicle.

Springs may thus be made less rigid than usual, so as to be more elastic without a load; the curved surfaces shortening the length of the springs under a load, they will still be elastic enough, without endangering their strength.

KENNETH.

October, 1853.

Burton-on-Trent, October, 1853.

HENRY TURTON.

CONDIE'S STEAM-HAMMER.

On my return from the country, my attention has been called to an article in your well-conducted *Journal*, of last month, on the subject of a steam hammer, stated to be the invention of Mr. William Brown, of Chapelball, near Glasgow. My present object in writing to you is to

TURTON'S ELECTRO-MAGNETIC ENGINE.

My two sketches annexed, represent a simple arrangement which I have designed for the application of electro-magnetic energy for the production of rotatory motive power. Fig. 1 is a side elevation, and fig. 2 a corresponding end view of the apparatus. A, A, are two large electro-magnets alternately reversible by any of the already known means, and acting upon the oscillating armature, B, which armature is keyed on firmly in the centre of the weigh-bar, C, at each end of which are fixed the right-angled arms, D. These arms, by means of four jointed straight

Fig. 1.

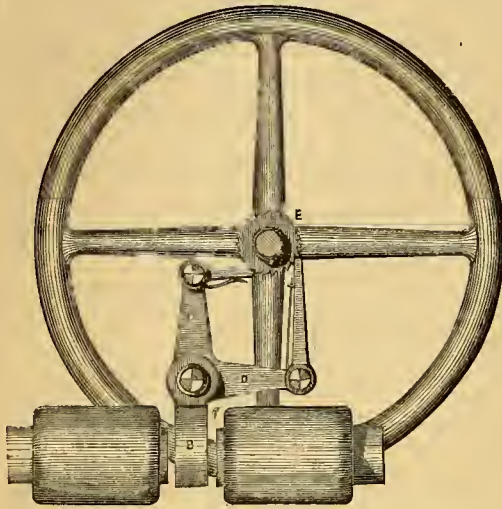

melting. Silver, as used by Mr. Lassell, he also found excellent; but he was against the use of fluxes, as most injurious. The author passed over the casting and grinding with very slight notice; but dwelt on the composition and figuring of the polisher as of great importance. The composition as used by him was pitch and resin, and a small admixture of flour was found useful. The surface he grooved with concentric equidistant circular grooves, and not in parallel and cross grooves, as used by Lord Rosse and Mr. Lassell. These concentric grooves he crossed by radial grooves, widening as they receded from the centre, so as to be bounded by curved outlines. By giving proper form and dimensions to these curves, the parabolic form could be most accurately given to the speculum in the process of polishing. The form of the curved outlines of these radial grooves he

Fig. 2.

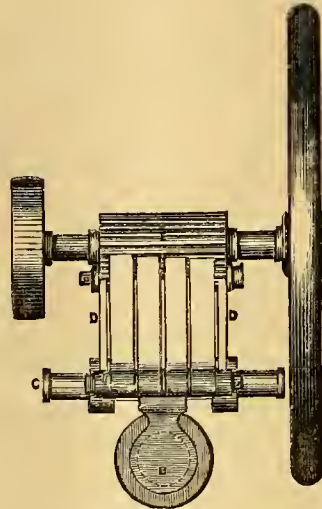

found should be parabolic. He concluded by stating the importance of not having the speculum too thin, and of using proper precautions in mounting and supporting it, to avoid any chance of the form being altered.

Dr. Scoresby regretted that, having been in another Section, he had not heard the early part of the communication of Mr. Sollitt; but he rather thought Lord Rosse used concentric grooves in his polisher, as well as parallel and cross grooves.

Prof. Stevelly confirmed the accuracy of this statement, and added that his memory was quite clear that Lord Rosse considered it very important to use the copper and tin in atomic proportions, and said, in his papers on it, that uniformity of composition could not otherwise be hoped for. He also recognized the importance of using thick specula; the last which he had cast being not less than five inches thick. He also had used and recommended resin to be used, to harden the pitch and flour for a purpose which, by experience, he had learnt to be important. Lord Rosse had also, by the several motions and adjustments which he had contrived for the speculum and the polisher, reduced the figuring of the speculum to an almost certain function of time; so that, after the speculum had been a certain number of hours under the action of the polisher, he was well assured that the proper figure had been attained. Prof. Stevelly briefly described these motions and adjustments; and stated that the actual result was, an enormous circular disc of six feet

pieces steeled at the ends, act upon the ratchet roller, E, which is also of steel and keyed on to the fly-wheel shaft.

The straight pieces slightly differ in their respective lengths, so that if one be not always, another will nearly be in contact with a tooth, and light springs, at the back of each, keep them always close to the roller. This action is the same as that employed in Messrs. Harrison's "Infinitesimal taking up motion for power-loom," as described at page 94, Vol. V. of the *Practical Mechanic's Journal*.

The action of the apparatus is obvious; the slight, but powerful oscillating movement of the weigh-bar in either direction, produces a thrust in the same direction upon the teeth of the ratchet roller, and the lines of these forces have the advantage of being nearly always at right angles to the centre of rotation. The fly-wheel should make about 100 revolutions per minute, and the power of the magnets may be easily checked by a small governor, influencing the Rev. F. Lockey's well-known water regulator.

HENRY TURTON.

Burton-on-Trent, October, 1853.

PROCEEDINGS OF SCIENTIFIC SOCIETIES.

THE BRITISH ASSOCIATION AT HULL.

SECTION A.—MATHEMATICAL AND PHYSICAL SCIENCE.

THURSDAY.

"Continuation of Report on Luminous Meteors," by the Rev. Prof. Powell.

"On the Composition and Figuring of the Specula for Reflecting Telescopes," by Mr. Sollitt.—The writer commenced by stating that he had given his attention to this subject for years, and that he was more than ever convinced of its importance by the decided conclusion to which facts had led him, that reflectors, when once well and carefully made, were far less apt to deteriorate than refractors. In order to be intelligible to the Section, it was necessary for him to go over some ground familiar to the public since the researches of Lord Rosse, Mr. Lassell, and Mr. Nasmyth. He stated that he considered it to be a matter of prime importance, that the copper and tin should be used in exact atomic proportions. He, following the numbers given by Berzelius, used the following proportions:—Copper, 32; tin, 17.4. Lord Rosse's are, copper, 32; tin, 14.9. As the metal, when thus composed, was very hard, brittle, and difficult to work, he found that he could render it capable of reflecting white light equally well, if not better, and at the same time of taking a very uniform and beautiful polish, by introducing a little nickel in place of the tin,—and the following proportions he found on trial best:—Copper, 32; tin, 15.5; nickel, 2. He also found the introduction of a very small quantity of arsenic useful in preventing the oxidation of the tin when

aperture, without crack or flaw, and of a splendid uniform polish, and reflecting light from objects of a perfectly natural tint.

Mr. Varley said he had found that the use of a little zinc in the composition of the speculum metal took from it the liability to tarnish, which he had found so annoying. He expressed regret that Lord Rosse found it impossible to avoid microscopic pores in the construction of his speculum; his own experiments had led him to hope they might be avoided.

Mr. Lassell said, if he had heard Mr. Sollitt correctly, he had said that he used silver in the composition of his speculum metal; now this was a mistake, as he used no silver in its composition. As to the proper proportion of tin to be used with the copper, he believed it to be impossible to give an unvarying rule, as the copper of commerce was very irregular in its quality and purity. He found the best mode to be to add nearly the quantity of tin known to be required, which generally was from 14 to 15 parts tin to 32 copper; and then, weighing a small portion of that alloy, add to it by slow degrees known weights of tin, and, assaying it from time to time by the simple test of dropping it into water as soon as it acquired a certain brittleness and brilliancy of fracture, easily to be recognized by practice, then adding in the same proportion to the whole alloy. He did not experience the difficulty from pores which had been alluded to, and he was not aware that Lord Rosse complained of it. His mode of casting most assuredly gave the portion of the speculum which was to be ground and polished free from them.

Mr. Varley said, to a certain proportion of tin the brilliancy and perfection of the reflecting power of the alloy seemed to improve, although its brittleness also increased; but beyond a certain limit the tin did not appear any longer to combine with the alloy, for he had seen it in the process of cooling squeezed out, as it were, leaving the texture of the alloy spongy.

"On the Surface Temperature and Great Currents of the North Atlantic and Northern Oceans," by the Rev. Dr. Scoresby.

"On Dynamical Sequences in Cosmos," by W. J. M. Waterston.

MONDAY.

"On Magnetic Phenomena in Yorkshire," by J. Phillips.

"On New Laws of Magnetic and Diamagnetic Induction," by Professor Plücker, of Bonn.

"On the Distribution of Electrical Currents in the Rotating Disc of M. Arago," by Professor Matteucci.

"On the Magnetism of Rotation in Masses of Crystallized Bismuth," by M. Matteucci.

"On the Magnetism of Rotation developed in very small Insulated Metallic Particles," by M. Matteucci.

"On the Elasticity of Stone and Crystalline Bodies," by E. Hodgkinson.

"Observations on the Density of Saturated Vapours and their Liquids at the Point of Transition," by J. J. Waterston.

"On a Law of Mutual Dependence between Temperature and Mechanical Force," by J. J. Waterston.

SECTION B.—CHEMICAL SCIENCE.

THURSDAY.

"On the Chemical Action of the Solar Radiations," by Mr. R. Hunt.

"On the Employment of the higher Sulphides of Calcium as a Means of Preventing and Destroying the Oidium Tuckeri, or Grape Disease," by Dr. Astley P. Price.—Of the many substances which have been employed to arrest the devastating effects of this disease, none appear to have been so pre-eminently successful as sulphur, whether employed in the state of powder or flowers of sulphur, or by sublimation, in houses so affected. Notwithstanding the several methods described for its application to the vines, I am not aware that any had been offered in 1851, when these experiments were instituted, by which sulphur might be uniformly distributed over the branches, and be there deposited in such a manner as to be to some extent firmly attached to the vine. Three houses at Margate, in the vicinity of the one in which the disease first made its appearance in England, having been for the space of five years infested with the disease, and notwithstanding the employment of sulphur as powdered and flowers of sulphur, no abatement in its ravages could be discovered.—I was induced to employ pentasulphide of calcium, a solution of which having been found to act in no way injuriously to the young and delicate shoots of several plants, was applied to the juices in a dilute condition; the object in view being, that the compound should be decomposed by carbonic acid, and that the excess of sulphur should be deposited with the carbonate of lime in a uniform and durable covering on the stems and branches of the vines. This was adopted, and although but few applications were made, the stems became coated with a deposit of sulphur, and the disease gradually but effectually diminished, inasmuch that the houses are now entirely free from any trace of disease, or symptoms of infection. The young shoots are in no way injured by its application, and the older wood covered with this deposit of sulphur continues exceedingly healthy. This was, we believe, the first employment of the higher sulphides of calcium as a vehicle for the application of sulphur to the stems and foliage of diseased vines. Specimens were exhibited from vines which, in 1851, were covered with disease, and which have, since the autumn of that year, received no further treatment. The vines in the immediate neighbourhood, and adjoining one of the houses, are covered with the disease, but, notwithstanding their close proximity, no indication of the disease has at present been detected in either of the three houses.

"On the Effect of Sulphate of Lime upon Vegetable Substances," by Chevalier Claassen.

"On Crystals from the Sea-coast of Africa," by J. Pearsall.

"On the Chemical Constitution of the Humber Deposits," by J. D. Sollitt.

FRIDAY.

The Rev. T. Esley read a paper "On the Cause of the Transmission of Electricity along Conductors generally, and particularly as applied to the Electric Telegraph." Prof. Andrews described a simple instrument for graduating glass tubes. The divisions admit of being varied in length to the $\frac{1}{17000}$ of an inch.

"On the Origin and Composition of a Mineral called Rotten-stone," by Prof. Johnston.

TUESDAY.

"On the Properties and Composition of the Cocoa Leaf," by Professor Johnston.

"Description of some New Kinds of Galvanic Batteries," invented by Mr. Kukla of Vienna.—The combination used in one of these is antimony, or some of its alloys for a negative plate, with nitric acid of specific gravity 1.4, in contact with it, and unamalgamated zinc, for a positive plate, with a saturated solution of common salt in contact with it. A small quantity of finely powdered peroxide of manganese is put into the nitric acid, which is said to increase the constancy of the battery. The alloys of antimony which Mr. Kukla has experimented with successfully, are the following:—Phosphorus and antimony, chromium and antimony, arsenic and antimony, boron and antimony. These are in the order of their negative character, phosphorus and antimony being the most negative. Antimony itself is less negative than any of these alloys. The alloys are made in the proportions of the atomic weights of the substances. All these arrangements are said by Mr. Kukla to be more powerful than when platinum or carbon is substituted for antimony or its alloys. In this battery a gutta-percha bell-cover is used over the antimony, and resting on a flat ring floating on the top of the zinc solution; this effectually prevents any smell, and keeps the peroxide of nitrogen in contact with the nitric acid solution.—When a battery of twenty-four cells was used, Mr. Kukla found that, in the third and twenty-first cells, pure ammonia in solution was the ultimate result of the action of the battery; but only water in all the others. This experiment was tried repeatedly, and always with the same result.—A battery was put into action for twenty-four hours; at the end of that time the nitric acid had lost thirteen-twentieths of an ounce of oxygen, and one quarter of an ounce of zinc was consumed. Now, as one quarter of an ounce of zinc requires only 0.06 of an ounce of oxygen to form oxide of zinc, Mr. Kukla draws the conclusion, that the rest of the oxygen is converted directly into electricity; and this view, he says, is confirmed by the large amount of electricity given out by the battery, in proportion to the zinc consumed in a given time. In the above battery, each zinc plate had a surface of forty square inches. The addition of peroxide of manganese does not increase the effect of the battery, but it makes it more lasting—the peroxide of nitrogen, formed in the bell-cover, taking one atom of oxygen from the peroxide of manganese; this is evident from only the oxide of manganese being found in the battery after a time. In the salt solution no other alteration takes place than what is caused by the oxide of zinc remaining in a partly dissolved state in the solution. For this battery, Mr. Kukla much prefers porous cells, or diaphragms of bisquit ware, as less liable to break, and being more homogeneous

No. 69.—Vol. VI.

in their material than any other kind. This battery is very cheap, antimony being only 5d. per lb., wholesale, and the zinc not requiring amalgamation.—The second arrangement tried by Mr. Kukla was antimony and amalgamated zinc, with only one exciting solution, viz., concentrated sulphuric acid. This battery has great heating power, and the former, great magnetizing power; it, however, rapidly decreases in power, and is not so practically useful as the double fluid battery, which will exert about the same power for fourteen days, when the poles are only occasionally connected, as in electric telegraphs. Certain peculiarities respecting the ratio of intensity to quantity, when a series of cells is used, have been observed, which differ from those remarked in other batteries. Mr. Kukla, on directing his attention to the best means of making a small portable battery for physiological purposes, has found very small and flat Cruikshank batteries, excited by weak phosphoric acid (one of glacial phosphoric acid to twenty of water), to be the best. Phosphoric acid being very deliquescent, and forming with the zinc, during the galvanic action, an acid phosphate of zinc. A battery of this description does not decrease in power very materially until it has been three hours in action.

"Report on the Gases evolved in Steeping Flax, and on the Composition and Economy of the Flax Plant," by Professor Hodges.—The investigations directed by the Association, at the Belfast meeting, with respect to the gases evolved in the steeping of flax, and the composition of flax straw, are in progress, and will be reported at the next meeting. The gases of the fermenting vat have been analyzed by the methods of Professor Bunsen, and have been found to consist of carbonic acid, hydrogen, and nitrogen. No sulphuretted hydrogen has, in any case, been detected. Several analyses of the proximate constituents of the dressed fibre and of its inorganic ingredients have been made, which show that a considerable amount of the nitrogenized and other constituents of the plant are retained in the fibre even after steeping and dressing have removed the structures unsuitable for textile purposes.

"On the Causes, Physical and Chemical, of Diversities of Soils," by Professor Johnston.

"Note on the Advantages arising from the Purification of Coal Gas, by the application of Water in an instrument called 'The Scrubber,'" by G. Lowe.

SECTION C.—GEOLOGY AND PHYSICAL GEOGRAPHY.

THURSDAY.

"On some of the Physical Features of the Humber," by J. Oldham.

"Notices and Observations on the Humber," by T. Thomson.

"On the Waste of the Holderness Coast," by G. G. Kemp.

"On the Character and Measurements of Degradation of the Yorkshire Coast," by Dr. J. P. Bell.

"On the Remains of the Hippopotamus, found in the Aire Valley Deposit, near Leeds," by H. Denny.

"On the Comparative Richness of Auriferous Quartz extracted at different Depths from the same Lode," by Dr. J. Blake.

SECTION D.—ZOOLOGY AND BOTANY, INCLUDING PHYSIOLOGY.

THURSDAY.

"Notices of some Living Aquatic Birds at Sautry House, near Dublin," by W. C. Donville.

"On some Discoveries relative to the Chick in Ova, and its Liberation from the Shell," by Dr. Horner.

"Notice of the Reproduction of the Lower Extremities in a Warm-blooded Animal," by Mr. Allis.

"On the Utricular Structure of the Endochrome in a Species of Conferva," by Prof. Allman.

FRIDAY.

"On the Morphology of the Pycnogonida, and Remarks on the Development of the Ova in some Species of Isopodous and Amphipodous Crustacea," by Spence Bate.

Mr. J. D. Sollitt read a paper, prepared by himself, in conjunction with Mr. R. Harrison, "On the Diatomaceæ found in the Vicinity of Hull."

"On the Structure of Bursaria, a Genus of Infusorial Animalcules," by Prof. Allman.

"On the Nature of Ciliary Motion," by P. Duncan.

"On a Species of Priapulans, a genus of Echinoderms belonging to the Family Sipunculidæ," by Prof. J. Phillips.

"On the Structure of the Freshwater Polyp, *Hydra viridis*," by Prof. Allman.

TUESDAY.

"On Preserving the Balance between Vegetable and Animal Organisms in Seawater," by R. Warrington.

"On a New Species of Cometes, a Genus of Humming-birds," by J. Gould.

"Note on the Habits of Fish, in relation to certain Forms of Medusæ," by C. W. Peach.

"On the Pentasulphide of Calcium as a Remedy for Grape Disease," by Dr. Astley Price.

"On a method of Accelerating the Germination of Seeds," by R. Hunt.

"Report on the Vitality of Seeds," by H. E. Strickland.

"On the Partridges of the Great Water-shed of India," by H. E. Strickland.

"On the connection between Cartilage and Bone," by Dr. Redfern.

"On the Artificial Breeding of Salmon in the Swale," by J. Hogg.

"On Photographic Plates and Illustrations of Microscopic Objects in Natural History," by Dr. Lankester.—The object of the author was, to draw attention to photography as a means of procuring accurate copies of objects of natural history,

2 B

more especially of those only seen by the microscope. The disadvantage of drawings in natural history was, that they more often represented the views of the author than correct delineations of the object. This was so much the case with drawings of microscopic objects, that the representations of different observers of the same thing could hardly be recognized as similar.

"Notes on the Growth of *Symphytum officinale* in the Botanical Gardens of the Royal Agricultural College," by Professor Buckman.

SECTION E.—GEOGRAPHY AND ETHNOLOGY.

THURSDAY.

- "On Iceland, its Inhabitants and Language," by J. Hogg.
- "On the Production of Gold in the British Islands," by J. Calvert.
- "On Oceanic Currents of the Atlantic and Pacific," by A. G. Findlay.
- "On the Manners and Customs of the Jakutes," by Prince Emanuel Galitzin.

MONDAY.

- "A Sketch of the Progress of Discovery in the Western Half of New Guinea, from the year 1828 up to the present time," by G. Windsor Earl.
- "On the Popular Theory of an Arctic Basin. Is it true?" by the Rev. Dr. Scoresby.
- "On the Traces of a Bilingual Town (Danish and Anglo-Saxon) in England," by Dr. R. G. Latham.
- "On the dialects North and South of the Humber compared," by C. Beckett.
- "On Contributions to the Ancient Geography of the Arctic Regions," by Professor Rafius.

TUESDAY.

- "Notes on a Journey to the Balkan, or Mount Hæmus, from Constantinople," by Lieut.-General Jochims.
- "On the Interior of Australia," by A. Petermann.
- "Notes of an Excursion to the Supposed Tomb of Ezekiel," by T. K. Lynch.

SECTION F.—STATISTICS.

THURSDAY.

- "Statistics of the Produce of the Northern Whale Fisheries from 1772 to 1852," by H. Munroe.
- "On Decimal Coinage," by T. W. Rathbone.
- "The Results of the Census of Great Britain in 1851, with a Description of the Machinery and Processes employed to obtain the Returns," by E. Cheshire.
- "Electoral Statistics of the United Kingdom," by J. Edwards.

MONDAY.

- "Summary of the Census of Switzerland," by Professor P. Chaux.
- "On Excessive Emigration and its Reparative Agencies in Ireland," by Mr. Locke.
- "Suggestions for an Improved System of Currency and Banking," by Mr. Bennock.
- "On the Education of the Poor in Liverpool," by Dr. Hume.

SECTION G.—MECHANICAL SCIENCE.

THURSDAY.

"Introductory Address on General Improvements in Mechanical Science during the past year," by W. Fairbairn.—The first subject noticed by Mr. Fairbairn was Ericsson's Caloric Engine, from which so much had been expected. It was constructed, he said, on the same principle as the air-engine of Dr. Stirling, invented ten years ago, the chief difference being, that the air in Ericsson's engine is passed through wire gauze to take up the heat, instead of through plates of iron. The great objection to the engine appeared to be, that two-thirds of the power were wasted in passing the air through the gauze; and though it might be premature to pronounce an opinion before the results of the improvements lately effected were known, yet, if so much of the power was required for taking up the heat, Mr. Fairbairn could not but think it must prove a wasteful expenditure of fuel. The improvements that, during the last year, had been made in the application of the screw propeller, were opening a new era in the history of our war and mercantile navy, of which the recent review at Spithead might be considered an indication. We were now in a state of transition between the paddle and the screw, and he had no doubt that, in the progress of time, great improvements would be made in the construction of the engines, and in their applicability to the work, which would materially economize space and power in our steam-vessels. Mr. Fairbairn next alluded to the construction of an immense steam-vessel, which had been undertaken by Mr. Brunel and Mr. Scott Russell, of such vast dimensions that it would stretch over two of the largest waves of the Atlantic, and would thus obtain a steadiness of motion which would be a preventive against sea-sickness. This mammoth steamer is to be 680 feet long, with a breadth of beam of 83 feet, and a depth of 58 feet. The combined power of the engines would be that of 2,600 horses. The ship is to be built of iron, with a double bottom of cellular construction, reaching six feet above the water-line, and with a double deck, the upper and the lower parts being connected together on the principle of the Britannia tubular bridge, so that the ship will be a complete beam. It would thus possess the strength of that form of construction, and not be liable to "hinge," or break its back, as had been the case with other ships of great length. The double bottom would be a means of increased safety in other ways, for, if by any accident the outer shell were broken, the inner one would prove effectual to keep out the water. As an additional security, however, it was divided into ten water-tight compartments. The ship would be propelled by paddles and by a screw, which would be worked by separate sets of engines, so that if any accident occurred to the machinery of one, the other would be in reserve. He said he had no doubt that, if properly constructed, this ship

would answer the expectations entertained of its capabilities and strength, and that it would form, when completed, the most extensive work of naval architecture that had ever been constructed. The next subject to which Mr. Fairbairn adverted, was the improvements making in the locomotive department of railways, particularly to an engine constructed for the southern division of the North-Western Railway, from the designs of Mr. McConnell, which was the most powerful locomotive that had yet been made for the narrow gauge. The peculiarity of construction consisted in the great length given to the fire-box, in which the greatest amount of steam is always generated, and in the comparative shortness of the tubes, which were only half the usual length. The steam generated by this boiler was sufficient for any engine of 700 horse power. The engine was intended for an express train that would complete the distance from London to Birmingham in two hours. In manufacturing machinery there had also been great activity and progress during the past year; and it was gratifying, Mr. Fairbairn observed, to find accompanying this improvement in machinery a most prosperous condition in the working classes engaged in those manufactures—a prosperity which had never been equalled within his experience. He attributed this prosperous state of things to the combined operations of improvements in machinery, and the removal of commercial restrictions. The improvement which he more especially noticed was that of a new combing machine of French invention, applicable alike to cotton, to flax, and to wool. It combs the fibre instead of carding it, a number of small combs being applied in succession to the cotton or flax, by which means a much finer yarn can be produced from the same material than is possible by the former processes. As evidence of the present activity and enterprise in manufacturing industry, Mr. Fairbairn mentioned the erection of a mammoth alpaca woollen manufactory, by Mr. Salt, of Saltire, near Bradford, which was 550 feet long, 50 feet wide, and six stories high, besides offices, warehouses, and various other buildings connected with it. Their steam-engines to drive the machinery would be equal to 1200 horse power, and the factory would employ upwards of 3000 hands. The cost of the whole would be upwards of £300,000, and the enterprise was that of a single individual. Mr. Fairbairn concluded his *résumé* of manufacturing progress by noticing the improvements introduced by Prof. Grace Calvert, of Manchester, in the process of smelting the iron, by previously removing the sulphurous vapour from coal and coke. The results had proved most satisfactory, the strength of the iron produced by this process being about 40 per cent. greater than that made in the ordinary way.

"Report of the Committee appointed in 1852, to prepare a Memorial to the Hon. East India Company on the Means of Cooling Air in Tropical Climates," by W. J. Macquorn Rankine.—In the absence of Mr. Rankine, one of the Secretaries read the Report, which was founded on experiments with apparatus invented by Prof. Smyth, described by him at a previous meeting of the Association. The principle of the invention consists in cooling the air by expansion. The air at the temperature of the atmosphere is first compressed in a bell-receiver, and the heat generated by this compression is lowered by passing the air through a number of tubes immersed in water, by which means it acquires in its compressed state the normal temperature of the atmosphere—say 90° of Fahrenheit. The air then passes into another inverted bell-receiver, where it is expanded to the ordinary pressure of the atmosphere, and during this expansion it absorbs so much heat that the temperature is reduced to 60°. It is then admitted into the room to be ventilated. The compression of the air during the experiments in the first cylinder was equal to $3\frac{1}{2}$ inches of mercury per square inch above the pressure of the atmosphere, and the refrigerator exposed a cooling surface of 1100 square feet, which was considered sufficient to reduce the temperature of the air in passing through the tubes to that of the atmosphere, viz. 90°. The Report stated that, by means of this apparatus, 66,000 cubic feet of air per hour might be cooled from 90° to 60°, by a steam-engine of one horse power, which is required to raise and depress the bell-receiver. The advantage of cooling the air by mechanical means instead of by evaporation, was stated to be the avoidance of aqueous vapour with which the air is injuriously charged by the evaporating process.

"On Reaping Machinery," by A. Crosskill.—Mr. Crosskill gave an historical account of the invention of reaping machines, from their use by the Romans and Gauls to the present time; with a view to show, that though reaping machines had not been brought prominently to notice before the Great Exhibition, such implements had long since been invented, and that the reaping machines of Messrs. McCormack and Hussey were constructed on the same principles as those which had been previously made in this country. Among other English inventions of reaping machines, he mentioned one by Mr. Smith of Deanston, in 1812, which, from time to time, underwent improvements, and in 1835 it worked very successfully at the meeting of the Highland Agricultural Society. After that trial it was laid aside, as British farmers did not encourage, and, during the redundancy of labour, did not want such machines. In 1822, Mr. Ogle, of Remington, near Alnwick, invented a reaping machine, which appears to have served as a model for Mr. McCormack, as his machine is, in almost every particular, the same as Mr. Ogle's, a description of which was published in 1826. The same circumstances which prevented the adoption of Mr. Smith's reaping machine, also caused Mr. Ogle's to be laid aside; though in America, where labour is scarce, and the stalk of the corn more slender and dry, and therefore better adapted for the action of mechanical cutters, McCormack's reaper was soon in extensive demand. It was stated by Mr. Crosskill, that about 2000 of McCormack's machines are annually sold in the United States, and that Hussey's is in nearly equal request in that country. The celebrity acquired by those machines in the Great Exhibition, induced Mr. Bell, of Scotland, who had gained a prize in 1829 from the Highland Agricultural Society for a reaping machine, to bring his invention again into the field. In 1852 he contested with Mr. Hussey at the meeting of the Highland Society at Perth, and carried away the prize; and his reaping machine had proved victorious

on several subsequent trials. It was to this invention that Mr. Crosskill particularly directed the attention of the Section. It differs in several essential points from those of M'Cormack and Hussey. In the first place, the machine is propelled before the horses, which are harnessed to a pole in the centre of the machine, and not on one side; in the next place, the cutters act like large double-edged scissors, which clip the corn as the machine is propelled into it; and a further advantage is, that it gathers the corn after it is cut without requiring a man to rake it off, which is necessary in the two other machines. The arrangement of the self-acting gatherer consists of an endless band of canvas, on to which the corn falls as it is cut, and it is then thrown on one side by a continuous motion of the canvas as the machine advances. With this machine, Mr. Crosskill stated, one acre and a half of corn per hour may be cut with two horses and one man to drive them.

In the discussion which ensued, Mr. Samuelson, the maker of M'Cormack's machines, admitted that Bell's reapers cut the corn better than M'Cormack's, and that the saving of the hard work required from a man was an important advantage; but the draught of M'Cormack's machines, he said, is lighter, and they are less costly. It was stated, that the cost of Mr. Bell's reaper is double that of Mr. M'Cormack's or Mr. Hussey's, the one being £40, the other £20. Mr. Crosskill stated, in reply to questions respecting the difficulties encountered in the use of reaping machines when the corn is laid, that there is no difficulty in cutting and gathering laid corn, if the machines meet it inclined towards them, so that it may fall on the gathering board as it is cut.—Models of the three machines were exhibited.

MONTHLY NOTES.

PETTITT'S ARTIFICIAL OR FISH GUANO.—The offer by the Royal Agricultural Society of a prize of £1,000 for an artificial fertiliser, as an economical substitute for guano,* has met with a reply—if not in the letter, at least in the spirit of the original suggestion—in Mr. Edwin Pettitt's "Fish Guano." It is well known that not only is there a deficiency of a really good guano, but that there is an immense sale carried on with various inferior descriptions, as well as fictitious articles, having little in common with the real thing but the name. These facts, and the contemplation of the very depressed state of the Colonial, Irish, and Scotch fisheries, have led to the invention, since patented by Mr. Edwin Pettitt, C.E., of an artificial guano, possessing all the fertilising properties of the best Peruvian, and which practical results have since stamped with as high a commercial value.

Guano, properly so called, is simply fish, which, having undergone decomposition in the stomach of the sea bird, is deposited on the barren islands of the Pacific to dry. Mr. Pettitt's patent guano is also simply fish, which, having been decomposed by chemical solvents, is dried by artificial means. Desirous of rigidly testing the actual value of his production, Mr. Pettitt has made various manures, and submitted them for analysis and practical trial to some of the first chemists and agricultural men of the day. The annexed table shows the general result as compared with various real guanos:—

Comparative Analyses of various Guanos.

	Analyzed by Professor Way.		Analyzed by Thompson.		Analyzed by Thompson (No. 102).		Analyzed by Way and Ure.		Analyzed by Way and Ure.		Analyzed by Ure and Teschemacher.		Analyzed by Nesbitt.		Analyzed by Way, Ure and Teschemacher.		Analyzed by Nesbitt.		Analyzed by Nesbitt.	
	No. 1.	No. 2.	No. 3.	No. 4.	No. 5.	No. 6.	No. 7.	No. 8.	No. 9.	No. 10.	No. 11.	No. 12.	No. 13.	No. 14.	No. 15.	No. 16.	No. 17.	No. 18.	No. 19.	No. 20.
Molasses	4.93	2.10	none	21.87	22.74	26.50	29.46	24.81	163.6	17.92	14.47									
Organic matter	8.73	72.59	95.60	48.72	47.55	41.81	19.50	22.90	13.16	14.98	7.85									
Sand, &c.	1.25	none		1.01	1.11	0.80	22.70	7.80	2.16	2.80	14.47									
Earthy phosphates	4.06	23.20	3.50	21.09	19.89	28.70	31.00	14.20	60.20	59.43	29.54									
Alkaline salts, &c.	1.50	2.20	1.50	7.31	7.89		7.24		7.45	6.29	33.67									
	100.00	100.00	100.00	100.00	100.00	100.00	100.00	100.00	100.00	100.00	100.00									
Ammonia	16.78	12.90	13.90	14.94	15.51	9.50	5.47	4.68	2.66	0.76	0.47									

The bearing of this tabulated statement will be understood, when it is remembered that the present standard for valuing manures is, that every pound weight of ammonia appearing on analysis is worth 6d.; every pound of super-phosphate of lime, 2d. As to the question, whether the raw material—fish—can be obtained in sufficient quantities for the establishment of a manufacture, the patentee goes at once to Ireland in support of his position; but he has also been at some pains in gathering statistics on the coasts of England, Newfoundland, Labrador, and the great Norwegian fisheries. It is a fact, that fish may be bought at the established fisheries on the English coast, where labour is dear, population great, and money plentiful—where the market for eatable fish is large, and seemingly never over-

stocked, at a price which has justified persons of capital and judgment in embarking in the business, namely, 30s. per ton. Hundreds of shiploads of fishy matter may be obtained from the colonies of British North America, and from the Loffoden Islands in Norway, for little more than carriage. That abundance of fish for the purpose may be found on the coasts of Ireland, appears from a large and elaborate blue book prepared for the House of Commons, on the subject of Irish fisheries, in the year 1836, corroborated by evidence collected from gentlemen in the Coast Guard service, and others resident in Ireland at the present time. It appears from the printed evidence, that the whole western coast of Ireland swarms with fish. That seals abound—now useless, except for skin and liver. That whales annually visit the coast, and many thousands of large sunfish, or basking sharks, from 20 to 40 feet long, are now useful for their livers only. That thousands of barrels of the waste of the fisheries—the most nitrogenous part—are annually thrown away at the curing stations. That there are 44 000 Irish fishermen who have not more than half a year's employment. That from the wonderful reproductiveness of fish, it is practically impossible to exhaust the British, much less the Irish Atlantic waters. That trawl boats usually throw overboard dead fish, weight 1½ or 2 tons for every 1 ton now taken to shore. That there is no doubt of the fish being obtainable on the Irish west coast—say Galway—at a less price than 30s. per ton, at which price large quantities can be secured. And although the manufacturer can afford to give £2. 10s. for each ton of fish, it is not to be supposed that it will cost so much for some time to come, if bought with judgment, and properly collected. It is proposed to establish several stations at Sligo, Clifden, Westport, or Galway, and in other places where the piers and harbours of the Government Commissioners were erected, with suitable plant to each. This would be of a remarkably simple description. Competent agents at these stations would make it their business to receive every description of fish brought to them at a regular contract price, to encourage the fishing population to resort to their depôts as a sure and ready cash market for every description of fish. If needful, they should be provided with carrier-boats, to accompany the fishing fleets to sea, and collect the waste and uneatable produce on the fishing ground itself. This plan, which has been well received by the English maritime population, may be well imagined to be a boon to that of Ireland. The expenditure by the State in aid of the Irish fisheries, since the commencement of the century, has amounted to £250,000; but as the Government could not supply the population with money to purchase the fish when caught, the plan failed to do any lasting good. Supposing each ton of fish to cost £2, the expense is estimated as follows:—To make fifty tons of manure, allowing 30 per cent. loss in weight of water—

100 tons of fish, at £2 per ton,.....	£200	0	0	
Chemicals,.....	17	10	0	
Labour, 10s. per ton on the finished article—say 50 tous,.....	25	0	0	
	Divide by 50)	242	10	0

Cost to manufacturer of a manure saleable at market for £9 on an average,..... £4 17 0

The great loss by desiccation might be economically obviated, and most profitably in a commercial point of view, by partially drying the fish by a suitable process, and then adding pulverized peat charcoal. Weight is gained in this manner, and a very valuable manure produced, fit for the drill, but lower in quality, not being so concentrated. It would appear that the difference between £9. and £4. 17s., namely, say £4. 3s., is ample to provide for the expenses of trade, interest on capital, depreciation of plant, and ultimate "profit." Mr. Pettitt has not claimed the £1,000 prize, for the very satisfactory reason that he is not prepared to give an article worth £9 a ton for £5, the price stipulated by the society.

REMOVAL OF THE TURNIP FLAVOUR IN MILK.—Mr. Skilling, of the Glasnevin Model Farm, treats his milk in the following manner, for the removal of the nauseous turnip flavour. He reduces a small quantity of saltpetre to powder, and then pours upon it as much water as will just dissolve it. Of such a saturated solution, he takes a wine glassful for ten quarts of milk, the saltpetre being placed in the pail before commencing to milk. The result is peculiarly successful.

PERCUSSION BLASTING CARTRIDGE.—Since the previous reports on Capt. Norton's several explosive contrivances, the gallant inventor has considerably extended his valuable experiments, and the Master General of the Ordnance having instructed Captains Haiden and Syngé, of the Royal Engineers, to examine the blasting cartridge, a most satisfactory inquiry has taken place at Spike Island, Cork. In boring horizontally, or with a downward inclination, clay may be met with in the narrow fork between the limbs of the block, but boring through this, solid timber is again entered in the opposite limb. After the hole is bored with the auger, its entrance should be widened for one-third the way with a riner—this admits of the iron rammer being placed in its proper position, when the blow from the fallen block above will impel it perfectly air-tight on the head of the cartridge. By causing the wooden block, suspended by a rope, or supported on an inclined plane, to strike the iron rammer in a slight degree obliquely, a section of the root of a tree, or of a rock, can be separated in the direction required in like manner, and more efficiently than by the powerful leverage of a long crowbar, because the severing power of the explosion and leverage of the iron rammer act simultaneously. In blasting rocks either above or below water, a cylindrical plug of deal, or other wood, about three inches long, and the same diameter as the bore, may be used, the plug having on its lower end a broad-headed iron nail of conical form, this will be driven into the plug by the force of the blow above, and the explosion of the cartridge below, thus forming a perfect condensed tamping—the tamping and cartridge may be all in one, thus making one action or motion instead of two.

* Practical Mechanic's Journal for January last.

The cartridge may have but one percussion cap, and that at its lower end, which need not be put on till it is to be used. They can be packed for carriage with perfect safety, and may be made water-proof by a coating of Japan varnish, such as is used in varnishing iron and other metal. In blasting, in the ordinary way with a clay, ponded brick, or sand tamping, if a misfire occurs, it is necessary to remove the tamping, in order to insert a fresh fuze or priming, but with the percussion cartridge, if a misfire takes place, it is only necessary to drop a short cartridge upon the one that missed fire, and the ignition of the upper cartridge will also fire that below it. The percussion appliance fitted into the wooden head, or tamping, of the cartridge, and charged with the composition that lucifer matches are primed with, is the same as that for the rifle percussion shell, illustrated by diagram 13 in Col. Beamish's appendix to Col. Chesney's lecture on fire-arms; also, in the *Practical Mechanic's Journal* for February last, and in Captain Norton's pamphlet. The head of the cartridge is, in fact, a wooden percussion shell, striking, or being struck, "point foremost." The percussion head, or wooden tamping, may be charged by dropping a few heads of Bell's lucifers into the hollow chamber, then pouring over them about a drachm of gunpowder; the wooden plug, fitting air tight, is then inserted, projecting about an inch; the blow on the plug ignites the charge, bursts the tamping, and fires the cartridge, something on the principle of the brass tube and piston for igniting the German amadu, or tinder. In order to prevent the block from falling off the head of the iron rammer, a deep hoop of sheet-iron is secured to its lower end, so that it falls on the iron rammer like an extinguisher, or inverted bucket. Another modification of the cartridge, by which it is fired in the centre, is this—half the charge of powder is poured into the hole bored in the root of a tree or a rock, a small pill-box, about the size of a hazel nut, and containing half a dozen lucifer heads of Bell's matches, together with a little fine gunpowder and pounded glass, is dropped on the gunpowder, the remainder of the powder of the required charge is then poured in, and the blow of the iron or wooden rammer crushes the pellet, and fires the charge, something after the manner of the pellet in the percussion shell explained by diagram, No. 5, in Captain Norton's pamphlet. The experiments were carried on without using a triangle for suspending the wooden block, and in place of it, the iron rammer had the block fixed on its head, a steel pin passed through the iron rammer, and supported it in the bore of the rock; a rope was attached to the pin, and when the men retired to a safe distance, the man who held the rope drew out the pin, when the rammer, falling on the head of the cartridge, fired it; this is a more simple way of causing the rammer to fire the cartridge, than that of the triangle. After a series of experiments it is found that, for blasting rocks, it is best to place over the powder charge a plug of deal of the same diameter as the bore, and about three or four inches long, having its lower end hollowed out for about an inch and a half, and of a cone form, a broad-headed iron tack or nail is fixed in the centre of its upper end, the lower percussion cap of the short cartridge rests on the head of this tack; the length of the short cartridge is about a quarter of an inch more than the diameter of the bore, and the fire from the short cartridge is sure to pass between the sides of the plug and the rock, and to fire the powder charge below the plug or wooden tamping. In blasting timber, such as the large roots of trees, no plug or tamping is necessary; the percussion pill-box is in this case used instead of the short percussion cartridge, the iron rammer fitting air-tight, doing the duty of a tamping. The iron or steel pillar is no longer used in forming the cartridge or blasting charge. In using the short percussion cartridge, a blow is required to ignite it, but in using the percussion pill-box a crush is sufficient to ignite it. In

this latter case a plank of timber raised at one end about four inches above the head of the iron rammer, and then allowed to fall on it, will fire the percussion mixture, and explode the blasting charge. The phlogistic pill-box, with its quill-guard, which has proved so efficient for blasting tree roots—seems well suited for firing the charge in a submarine percussion petard—by the crush or pressure against a

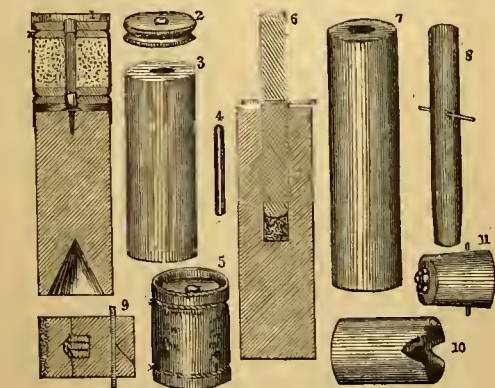

ship's side, whether the action arises from a wave, the tide, an ocean current, or a "gentle zephyr." In using it, the wooden end is placed over the blasting charge, the phlogistic pills being a mixture of lucifer composition, pounded glass, and gunpowder, prepared by Mr. O'Connell of Little Cross Street, Cork. The percussion cartridge is indeed a modification of the inventor's rifle shell, as well as of the spheroidal percussion shell. The annexed diagrams represent the phlogistic cartridge and phlogistic pill-box, in very full detail. Fig. 1 is a longitudinal section of the short cartridge with its wooden tamping; 2 is the top or bottom of the short cartridge; 3, wooden tamping, with iron tack; 4, steel pin of short cartridge; 5, short cartridge; 6, percussion tamping, charged; 7, percussion tamping, not charged; 8, percussion plug with quill-guard; 9, section of phlogistic pill-box, with quill-

guard; 10, phlogistic pill-box, with pounded glass at the bottom; 11, wooden head of pill-box, with quill-guard, and tipped with lucifer composition.

ABUSES IN THE UNITED STATES PATENT OFFICE.—The following paragraph appears in the *Wall Street (New York) Journal*:—"Serious and just causes of complaint exist against this office. They appear to arise through the inefficiency and ignorance of the Examining Corps. The examiners have almost unlimited power as judges, jurors, and counsel, upon the genius and toil of the poor inventors. They exercise it without discrimination, and wield it without judgment, and in the most wilful ignorance or misconception of the spirit and intent of Congress in the laws it framed, and the office it by them established, to promote the useful arts and sciences. The equity of those laws was to afford aid and protection to inventors. The practice of the examiners is to give them the least possible of either, and, on the contrary, to throw all possible obstacles in their way. The intention of Congress was to encourage invention, by granting the inventor letters patent for any useful and novel machine, and to construe liberally the result of his labour for months or years, so as to give him such protection by patent, wherever that useful novelty was plausibly apparent. The action of the servants or examiners the inventor employs and pays, is to reject and condemn his labour, under any phase in which it may be presented. And so they refer him to previous inventions wholly different and distinct, or to some old and rare work, obtainable, perhaps, only in the Patent Office library; and when read, found to contain nothing relevant to the invention at issue."

CONCENTRATED ARTICLES OF FOOD.—One of the most interesting of the foreign contributions to the Great Exhibition, 1851, was the "American Meat Biscuit" of Mr. Gail Borden, who has been most successful in combining the best wheaten flour with the nutriment of the finest beef, in the form of a dry, brittle cake, quite inodorous, and capable of remaining good for an unlimited period. To use this biscuit as a soup, all that is necessary is hot water and seasoning. A pound of the prepared substance contains the essence of five pounds of beef, mixed with half a pound of flour; so that a single ounce, grated down in a pint of water, produces a rich, nutritious soup. It is said, indeed, on satisfactory evidence, that ten pounds of the substance will support a healthy working man in full condition for a month. Since the appearance of Mr. Borden's invention, an establishment has been put in operation by another American, at Hinesburgh, Vermont, U. S., for the preparation of potatoes in a preserved condition. The prepared article is termed "Brinsden's Imperishable Potato;" and it is made by first stripping the roots of their skins, the solid matter of the potato being then reduced to pulp and dried. The mass is then broken up, so as to resemble that essentially American dish, "hominy," in which condition it occupies one-sixth only of the original bulk of the roots. It is then packed in canisters for sale. These two articles, with M. Fadeuilhe's "Solidified Milk," form a triad of very satisfactory improvements in concentrated articles of food.

QUEEN'S COLLEGE, BIRMINGHAM.—We beg to call attention to the following extract from the report presented to the annual meeting of the governors of this institution, at which the Right Hon. Lord Lyttelton presided, in reference to the all-engrossing subject of the day—industrial education:—"Your Council cannot record the complete organization of the engineering department, without drawing attention to the great and growing need of such industrial education as may, by its efficient administration, be supplied within your walls. One of the most striking results of the great and increasing facilities of communication, and of the wonderful improvements of machinery, is the equalization of districts, and even nations, as to facilities of manufacturing production. The time has gone by when a branch of industry can be confined to that locality which may, from natural advantages, have given it birth. The railway, and steam applied to locomotion, place the raw materials everywhere within the reach of the enterprising capitalist, no less than it furnishes him, on the locality of his own choosing, with the power and appliances of working up that material into the finished product. Nothing, therefore, now remains as the certain source of superiority in manufactures, except the intelligence and skill which may be brought to bear upon them. The nation which converts the raw material into the finished article, with the clearest insight into the scientific laws concerned, and in the strictest conformity with them, will assuredly be henceforth in the ascendant. It was made manifest by the Great Exhibition of 1851, that we had, to say the least, no superiority over foreign countries in these important particulars. The lead we have hitherto maintained in manufacturing industry has been due to other causes—to our capital, to our laborious and numerous population of handicraftsmen, and to the natural resources of our island. Great though these elements of superiority certainly are, they do not of themselves secure us from successful competition; they may, they certainly will, be neutralized, and at last overcome, by any who shall surpass us in assiduous cultivation of science in its practical applications. Your Council, therefore, think, that the necessity for an improved industrial education of those who are to be employed in civil and military engineering, architecture, and the higher branches of manufactures, is evident. That the acquisition of such knowledge is also held by those best in a position to judge, to be most urgent, may be inferred from the anxiety manifested in the highest quarters to establish and encourage schools of the kind in question. When, therefore, your Council propose to offer, in the engineering department, an education which shall not only discipline and invigorate the intellect generally, but call out those faculties, and impart that knowledge, which have to be exercised in the arts of industry, and shall, conjointly with the theory, make practice also familiar, by models, apparatus, and workshops, they feel that they are, as becomes the comprehensive plans of your institution, doing their part to improve a branch of education hitherto most inadequately cultivated in this country, though plainly important to the national welfare, and absolutely essential to the continued prosperity of this town and district. Believing that our intelligent merchants and manufacturers are fully alive to the necessities of the

case, your Council look forward with confidence to obtaining every encouragement and support in this part of their undertaking, and to a great accession of students, now that the department is brought into full operation.

WALKER'S SAFETY APPARATUS FOR RAILWAYS.—We have examined some very satisfactory working-models of this invention. It is intended to give the power of stopping an advancing train independently of the driver. For this purpose, a long curved lever is fitted to the locomotive, at any convenient part, near the level of the road. This lever is in communication with the shut-off valve, whistle, or brake apparatus; and it is actuated by means of a stop-piece on the road, which is caused to rise up in the path of the lever, when the train is to be stopped. The mechanism for elevating the stop is intended to be worked by the signal-cords, and in conjunction with the signals already in use, near stations and junctions. The invention does not stop here, but also comprises an arrangement, to be employed upon the entire length of the railway, whereby each train prevents a following train from approaching too near. In addition to the lever already alluded to, the locomotive carries a fixed bar, which acts upon a stop-piece on the road, and, by depressing it, causes the elevation of a stop-piece a certain distance in the rear, the stop-pieces being suitably connected for that purpose. These stop-pieces are to be placed at certain intervals along the line, so that if a train were approaching within a less distance, the stop-apparatus would bring it to a stand. The mechanism is such that, on the train in advance reaching a second stop, the first will be depressed; so that there is only one stop up at a time, and a following train can pass freely so long as there is a single stop between it and the train in advance. We shall shortly give a more detailed description of this invention, with illustrations.

FRENCH'S RAILWAY AXLE.—This is an arrangement of a divided or sectional axle, with the two halves connected together at the centre of the axle's length, as in our diagram, representing the joint in longitudinal section. It is by Mr. George

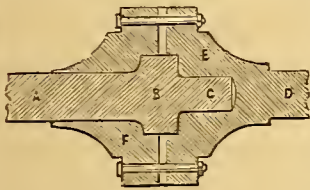

French of Bandon, near Cork, who has thus endeavoured to obtain a steady-working axle, which shall at the same time permit each wheel to act independently. The junction end of the half-axle, A, is formed with a swell, B, and a reduced projection, C, recessed into a corresponding hollow in the end of the other half-axle, D. The latter section has an expanded socket, E, embracing the swell, B, and a loose socket piece, F, is entered upon the end, A, for bolting up to clamp the two together. Thus, on sharp curves, the two wheels may run freely each as it lists.

MANUFACTURE OF STEEL.—HEATH v. SMITH: ACTION FOR INFRINGEMENT.
—This was an action on the prolonged patent of Mr. J. M. Heath,* originally obtained in 1839, for a process of casting steel by the use of carburet of manganese. Sir Fitzroy Kelly, for the defendant, said that he thought he should be able to prove that Mr. Heath had taken out his patent for one thing, and brought his claim for another. He said that the manufacture of carburet of manganese was not known before he made his experiments. He need scarcely tell them, that when a man took out a patent, he must explain intelligibly what the invention was. Mr. Heath, after having taken out his patent, proceeded to make his cast-steel by his new process for upwards of six months, but the article thus manufactured was so worthless that it was never even brought into the market. This was succeeded, some time afterwards, by another article, made by a totally different process, which certainly did make some improvement in the manufacture of cast-steel. The learned counsel went on to argue that the alleged infringement had not occurred, as the defendant made his cast-steel with ingredients totally differing, in their proportions, from Mr. Heath's specification, and that the use of oxide of manganese and carbon was resorted to previous to Mr. Heath's patent. Sir Fitzroy Kelly concluded by quoting a passage from Dr. Lardner's Cyclopædia, published in 1831, eight years before the date of Mr. Heath's patent, in which the use of carbon and manganese, in the manufacture of steel, was mentioned. Several witnesses were then called to prove, that black oxide of manganese and carbon had been used in casting steel, some years prior to the date of Mr. Heath's patent.—Sir Alexander Cockburn replied. The question for their decision was, whether the process carried on by the defendant was really an infringement of the patent. The question simply was, did the defendant, in his manufacture of cast-steel, make use of carburet of manganese? If they were to believe the statements of his own witnesses, it was most certainly the case.—His Lordship summed up, directing the jury to find for the defendant, on the evidence of the witnesses, who proved that they had used oxide of manganese and carbon, in the manufacture of cast-steel, before the date of Mr. Heath's patent.—The jury, accordingly, found a verdict for the defendant on the fourth issue, and for the plaintiff on the other issues. The effect of the verdict, however, was generally in favour of the defendant. The question as to the validity of the patent, after being referred from several legal tribunals, is at present before the House of Lords. If decided in favour of the patentee, the Sheffield steel manufacturers will probably have to pay over some thousands, by way of compensation.

PROGRESS OF SCREW-PROPULSION.—MARINE MEMORANDA.—It will be remembered by our nautical readers, that among the points of novel detail in the *America* yacht, as discussed at the time of the excitement originally caused by her fine sailing performances, was the fact of her being fitted with cotton sails, instead of common canvas. Many advantages have been enumerated by the Americans in favour of cotton for this employment, and the idea has now been extended to a

much wider application, in the hardly less celebrated vessel, the *Sovereign of the Seas*, which has succeeded the *Flying Cloud*, as the American nautical wonder of the day. In the *Sovereign of the Seas*, the ropes of the entire running rigging are also of cotton, which appears to be capable of receiving a more intense twist, whilst it is less liable to injury from frictional action than hemp. The cotton ropes are extremely smooth—an advantageous feature, long since developed in textile manufactories, where cotton bands are so extensively used—and they run with great ease through the blocks. The first cost is obviously much less than that of hemp. Another feature of economy arises from their possessing considerable value as old material, when worn out on board ship.

The *Valetta*, Peninsular and Oriental paddle-steamer, continues to sustain her reputation. Since we lately wrote of her performances, she has made the Malta and Marseilles run, 660 miles, in 46 hours, giving an average of $14\frac{1}{2}$ knots per hour.

A very satisfactory experiment has been made at Woolwich, with the view of adopting iron for use, in the shape of deck nails and bolts, in naval construction, instead of copper and composition metals. The trials have originated with a patent obtained by Messrs. Watt and Burgess, for coating and tipping iron nails with copper, so as to combine the strength and cheapness of iron with the preservative properties of the more costly metals. The first set of experiments were made with a view of ascertaining if the iron received any injury by the process. The coated iron was placed in the proving-machine, and stood the full strain of ordinary iron of the same dimensions, and in some instances it showed that an increase of strength had been obtained. It was also bent double by cold hammering, but it did not appear to be injuriously affected. The next series of experiments were made with reference to the possibility of separating the copper from the iron. On the bolts tipped with copper being placed in the hydraulic proving-machine, it was impossible, by any strain, to separate the copper from the iron, the copper, in every instance, breaking in the solid. Deck nails and bolts, tipped at one, and also at both ends, were then driven into African oak, the bolts being clenched in the usual way, and no separation or tearing off of the copper occurred. Two blocks of African oak were then fastened together by bolts tipped at both ends, and then clenched. The logs were subsequently separated by driving wedges between them, which had the effect of drawing the clenches through the rings, while the adhesion of the iron and copper remained perfect. The last experiment was again repeated, with the exception that one of the bolts used was all copper. On driving the wedges, the compound, or iron coated with copper bolt, held fast, but the copper one drew through the rings.

The ocean trial of anthracite fuel in the African Steam Navigation Company's Ship *Faith*, which we announced last month, has answered so well, that the fuel is now being used on an extensive scale. On her last trip, the *Faith* took 150 tons of Welsh anthracite, and managed it extremely well with the aid of her furnace steam-jets. She now takes out 500 tons of the same fuel for her voyage to the west coast of Africa. The consumption of anthracite is nearly one-third less than that of other coal; and as 360 tons of anthracite can be stowed in the space which 320 tons of ordinary coal usually take, it is reasonably assumed that the new fuel must be of great general benefit in steam navigation.

The issue of a Parliamentary Report on the existing means of communication between London and Dublin has caused some interest, from the magnitude of the reformatory machinery which it proposes. The mail service here is at present performed by the Dublin Steam Packet Company, who have an unexpired term of contract of seven years yet to run, with a bounty of £25,000 a-year. The mode in which the service has all along been performed is justly censurable, both as regards speed and accommodation, the defence of the Company being, that whilst the Government was its own mail-carrier, at a cost of £70,000 a-year, the present subsidy is hardly more than one-third of that sum. The time occupied at present in traversing the distance between the two capitals is 14 or 15 hours. The committee to whom we owe the report now before us, propose to do it in 11 hours, and they state that plans have been submitted whereby a still quicker passage may be effected. To carry out these views, a line of four boats, costing £120,000 each, is to be established. These boats are to be 3,000 tons burthen, 1,400 horse-power, and capable of running 25 miles within the hour; and the important evil of seasickness is to be removed by the stability which will arise from a length of 400 feet, and a breadth of 40 feet. This gigantic scale of operations sounds very well, and would appear to indicate prosperity of an overwhelming kind. But when we turn to the actual traffic statements, we find that, whilst the number of first and second class passengers, in 1844, was 122,760, there were no more in 1852 than 135,784, or an increase of but 13,024, even in the face of all the splendid railway facilities provided in the interval. During four months of the year, there is a partial crush of passengers; but for the remaining eight months, the average number of passengers conveyed by the railway company's boats is only 32, and by the Dublin Steam Packet Company, 24 or 25. How, then, are these enormous steamers to be worked, with anything like even a bare supporting return? There cannot be any reasonable doubt as to the general adoption hereafter of steamships of immeasurably greater tonnage than anything now in existence; and it is to be expected that the smooth motion of such enormous floating towns will entice many more sea-going passengers than the small craft of our own immediate times. The introduction of such vessels will, indeed, form a new and splendid era in the history of marine locomotion; but is the Dublin and Holyhead line in a condition to receive them?

A late trial of the *Fairy*, with Griffiths' screw, for six runs along the measured mile, gave a mean result of 12.463 knots per hour, with hardly any vibration. This was an increase of 3-10ths of a knot, upon the last trial with the same screw, but at a different pitch, both blades being at 9 feet $8\frac{3}{4}$ inches. This trial was to enable Mr. Griffiths to determine which was the best pitch for this

* See *Practical Mechanic's Journal* for March last.

screw to be worked with, and the result determined him to fix it at that above given, as the best, considering the power used for the speed obtained, with ease of motion. Mr. Murray, the superintending engineer of Portsmouth dockyard, will now cast a screw with these improvements before his eyes, to compete with Griffiths'.

The New York and Australian Steam Navigation Company has just placed the *Golden Age* steamer on the Australia and Panama station, with the intention of eventually running her between Australia and San Francisco. Externally, she resembles the Collin's liners. Her dimensions are—length, 285 feet; breadth, 43 feet 6 inches; depth of hold, 32 feet; and 2,864 tons register. She has a beam engine of somewhat peculiar construction, with a diameter of cylinder of 85 inches, and 12 feet stroke. But the boilers constitute the great novelty. They are each 40 feet in length, and are fitted up with furnaces at each end, the smoke-funnel ascending from the centre. By this arrangement it is claimed that economy in both space and fuel is gained, and the truth of the proposition is very evident, as far as regards space. There are eight furnace doors at each end of the boilers. The hull of the ship was built by Mr. W. H. Brown, of New York. The lower frames are of live oak, and the top frames, of locust and cedar. The entire hull is double diagonally braced with iron bars five inches wide by three quarters of an inch thick, and four feet apart. She is ceiled with eight-inch plank, the bilge keelsons are 14 inches square, and planked outside with six-inch plank; 13 keelsons run the whole length of the ship. The *Golden Age* has accommodation for 1,200 passengers of all classes, the steerage alone being fitted up for the accommodation of 600. Two of the saloons, of which there are three, one above the other, are panelled in rose, satin, and zebra woods; with crimson and gold plush and rich hangings, and adorned with mirrors. In the upper saloon the same general arrangements prevail, although, in place of the satin-wood panelling, the sides are finished in white and gold. In this saloon are two "family rooms," one finished in gold, the other in blue, with lace curtains, mirrors, drawers and closets. The company propose to construct five more vessels of a similar class.

The voyage out to Port Philip performed by the General Screw Steam Company's ship *Argo*, must be considered as the most successful one ever accomplished in connection with Australian steam navigation. It occupied only 65 days, four days of which were consumed in coaling at St. Vincent's, giving 61 days as the total period under steam and canvas. The overland route has thus been completely beaten by the *Argo*.

Since leaving Queenstown, several trials of sailing and steaming have taken place with the channel fleet. One under all plain sail, of four hours' duration, showed the following result:—

St. Jean d'Acre beat Duke of Wellington,	1,880 yards.
" " " " " " " " " " " "	2,145 "
" " " " " " " " " " " "	4,680 "
" " " " " " " " " " " "	6,548 "
" " " " " " " " " " " "	7,462 "

This trial was on a wind. In a trial off the wind, in a fresh breeze, heavy weather, starboard studding-sails set, the

St. Jean d'Acre beat Duke of Wellington,	1,020 yards.
" " " " " " " " " " " "	1,850 "
" " " " " " " " " " " "	4,770 "

The *St. Jean d'Acre* and the *Duke* beat all the others, and the *Arrogant* was last in a trial of the frigates. On the 6th the *Cruiser* joined the fleet. Subsequently the *Duke*, *St. Jean d'Acre*, and *Arrogant* had a trial of steaming. It was impossible to get steam up in the *St. Jean d'Acre* to more than 12lbs., in consequence of which the *Duke* headed her about 400 yards in a run of 15 miles, light wind on the bow, force 3. The *Duke* and *Acre* had another trial of steaming and sailing by the wind; average speed $10\frac{1}{2}$ knots. The *St. Jean d'Acre* was fast gaining on the *Duke*, when the engines of the latter stopped, and the trial was put an end to. The *St. Jean d'Acre* was, at the time, making 59 revolutions, having 20lb. pressure on her boilers. A final trial of Sir T. Mitchell's boomerang propeller has now been made with the *Conflict*, at the measured mile in Stokes Bay. The weather was fine; force of wind 1. The average speed of six runs was 9.913 knots per hour. The average of the second and third runs was 10.076 knots. The attainment of 10 knots an hour, within a small fraction, with so heavy a ship as the *Conflict*, is regarded as a convincing proof of the sound principle of Mitchell's propeller, especially when it is remembered that all the trials on board the *Conflict* have been made with a mutilated boomerang to suit the construction of that vessel. One-third, at least, of the working surface of the boomerang has been sacrificed to this necessity.

PROVISIONAL PROTECTIONS FOR INVENTIONS UNDER THE PATENT LAW AMENDMENT ACT.

When the city or town is not mentioned, London is to be understood.

Recorded May 25.

1281. William Baner, Munich, Bavaria—Improvements in the construction of vessels to be used chiefly at various depths under the surface of the water, and in machinery or apparatus connected therewith, for propelling, balancing, and steering the same, and for carrying on operations of various kinds on or under the surface of the water from within, upon objects without such vessels.

Recorded July 1.

1585. John Getty, Liverpool—Certain improvements in ship-building.

Recorded July 11.

1651. Felix L. Bauwens, Pimlico—Improvements in the manufacture of candles.

Recorded August 10.

1864. William E. Newton, 66 Chancery-lane—Improved preparation or composition to be applied to pigments, for the purpose of facilitating the drying of the same.—(Communication.)

Recorded August 2.

1807. Mead T. Raymond, 25 Clement's-lane, Lombard-street—Improvements in apparatus for retarding and stopping trains of carriages on railways.

Recorded August 12.

1892. Daniel I. Picciotto, 8 Crosby-square—Improvements in weaving.—(Communication from Chevalier G. Bonelli, Turin.)

Recorded August 20.

1948. William Vaughan, Stockport, and John Scattergood, Heaton Norris, Lancashire—Certain improvements in machinery, apparatus, or implements for weaving,

Recorded August 23.

1962. Thomas Herbert, Nottingham, and Edward Whitaker, same place—Improvements in warp machinery employed in the manufacture of piled and other fabrics.

Recorded August 24.

1968. George Culverhouse, Hull—Improvements in manufacturing compost or manure.

Recorded August 29.

2002. Peter A. le Comte de Fontaine Moreau, 4 Smith-street, Finsbury, and Paris—Improvements in apparatus for beating.—(Communication.)

Recorded September 8.

2063. Simpson G. Pape, 34 Gloucester Crescent, Camden Town—Breech ends, being a new suspensor for trousers, breeches, and drawers.

2064. James G. Lynde, jun., 37 Great George-street, Westminster—A pressure-governor, or self-acting apparatus for regulating the flow of water.

2066. John D. Brunton, Truro, Cornwall—An improved wind-guard or chimney-top.

2067. John Petrie, jun., Rochdale, Lancashire—Improvements in cans, or vessels, used for applying oil or other lubricating material to machinery.

2068. James Coate, 19 Marylebone-street, Regent-street—Improvements in tooth, nail, and hair-brushes.

2069. James Burrows, Haigh Foundry, near Wigan, Lancashire—Certain improvements in the formation or construction of rolled metallic plates.

2070. William Hall, Colliery, Castlecomer—Improvements in the conversion of peat into charcoal.

2071. Peter A. le Comte de Fontaine Moreau, 4 South-street, Finsbury, and Paris—Certain improvements in lighting for consuming the carbon escaping combustion in ordinary flames.—(Communication.)

Recorded Sept. 9.

2073. Philip Grant, and John Doherty, Manchester—Improvements in the mode or method of cutting and finishing brass-rule and wood regel, used in the art or process of letter-press printing and other similar purposes, and in the machinery or apparatus employed therein.

2074. John H. Johnson, 47 Lincoln's-inn-fields, and Glasgow—An improved apparatus for facilitating the acquirement of the art of reading.—(Communication from Messrs. Nicolas Chéron and Florimond N. Talempin, Paris.)

2075. Edwin Lumby, Ilalifax, Yorkshire, and Zachæus Sugden, same place—Improvements in needles or wires used in the manufacture of carpets, looped pile fabrics, and velvets.

2076. Michael L. Parnell, Strand—Improvements in the construction of locks.

2077. James Martin, Faversham, Kent—Improvements in locks.

2078. John Doyle, 17 Cambridge-terrace, Paddington—Invention of the better ventilation of field tents and marquees.

2079. Isaac L. Bell, Newcastle-upon-Tyne—Improvements in the manufacture of sulphuric acid.

2080. Charles Askew, 27½ Charles-street, Hampstead-road—Improvements in baths.

2081. Cyrien M. T. du Motay, and Edmond L. Daffos, 2 Rue Drouot, Paris—Improvements in the mode of bleaching fibrous and other substances.

2082. Jonathan Amory, Boston, U. S.—Improvements in furnaces.

2083. James Childs, Gilders-road, Brompton—Improvements in the manufacture of materials to render them suitable as substitutes for mill-board and such like uses.

2084. Henry Woodhead, Kingston-upon-Hull—Improvements in spinning machinery.

2085. Ernest A. Guoin, 110 Avenue de Clichy, Batignolles, Paris—Improvements in looms or weaving machines, applicable to the weaving of cotton, silk, flax, hemp, wool, or any other fibrous substances, by means of which improvements the warp threads are unwound more regularly from the warp roller, and the cloth or tissue taken up with more regularity, at the same time without straining the warp thread, and by means of a peculiar motion in releasing the tension on the warp thread he is enabled to give an elastic or back motion to the warp, which permits of all inelastic fibrous substances to be woven upon the power loom, and in case the web thread should break, the loom can continue in motion without the cloth roller continuing to take up, or without detriment to the tissue.

2086. A. V. Newton, 66 Chancery-lane—An improved manufacture of gas burner and gas regulator.—(Communication.)

2087. Robert Drew, Bath, and John Bayliss, Birmingham—Improvements in stay and other like fastenings.

Recorded September 10.

2088. William C. Forster, 84 Hatton-garden, Holborn—An improved manure.

2089. Arthur Warner, 34 Dorset-place, Dorset-square—Invention of the application of the fibrous part of the palm-tree and leaf, to arts and manufactures.

2090. John D. Brunton, Truro, Cornwall—An improved apparatus for separating gold or silver from their ores or other matters, by amalgamation.

2091. Stopford T. Jones, 11 Trington-terrace, Clapham-road—Improvements in propelling floating vessels, and in the mode of applying the propellers.

2092. John Grist, Islington—An improved stove jointing or shaping machine.

2093. Edwin Scragg, Buglawton, Cheshire—Improvements in steam-engines.

2094. Edmund Leyland, St. Helen's, Lancashire—Improvements in apparatus for the manufacture of sulphuric acid.

2095. Thomas W. Gilbert, Limehouse—Improvements in sewing sails and other articles.

2096. Charles Jacob, 6 Ingram-court, Fenchurch-street—Improvements in the manufacture of lime.

2097. Robert Tronson, Chamber of Commerce, Liverpool—Improvements in ventilating and preventing spontaneous combustion in ships and other vessels laden with coal, oil, or cinders.

2098. Thomas Metcalf, 19 High-street, Camden Town—Improvements in portable chairs and tables.

2099. John Webster, Ipswich—Improvements in the treatment of fatty and oily matters, to render them suitable for the manufacture of candles.

2100. John Ward, Saville-house, Leicester-square, and Edward Cawley, 24 Stanley-street, Chelsea—Improvements in chairs, couches, and tables.

2101. Joseph Marks and John Howarth, Massachusetts, United States—Certain new and useful improvements in machinery or apparatus for operating the brakes of train of railway carriages.

2102. Jules F. Chack, Castle-street—Improvements in machinery for cutting veneers.—(Communication.)

Recorded September 12.

2103. William Weild, Manchester—Improvements in lathes and in apparatus connected therewith, for cutting, turning, or boring wood, metal, or other substances.
 2104. John W. Child, Halifax, York, and Robert Wilson, same place—Improvements in valves and pistons.
 2105. John H. Johnson, 47 Lincoln's-inn-fields, and Glasgow—Improvements in the transmission of motive power, being an improved substitute for the crank.—(Communication from Jean Lasserre and Edmond Heusschen, Paris.)
 2106. Edward R. Turner, Ipswich—Improvements in grinding-mills for farm and other purposes.
 2107. John Lilley, junior, Jamaica-terrace, Limehouse—Improvements in mariners' compasses.
 2108. Joseph Maudslay, Lambeth—Improvements in boilers and furnaces for generating steam.
 2109. John Robison, Coleman-street, and William Jackson, Leman-street, Middlesex—Improvements in furnaces for effecting the consumption of smoke.
 2110. Alfred V. Newton, 66 Chancery-lane—An improved manufacture of printing blocks and cylinders.—(Communication.)
 2111. Louis A. Brocot, Paris—An improved construction of astronomical calendar.
 2112. Charles Cannon, 27 Dance-street, Liverpool—Improved machinery for obtaining motive power.
 2113. Alfred V. Newton, 66 Chancery-lane—Improved machinery for crushing and grinding mineral and other substances.—(Communication.)

Recorded September 13.

2114. Thomas H. Ewbank, South-square, Gray's-inn—Improvements in the manufacture of terry or looped fabrics, and in machinery for producing the same.
 2115. Charles F. Adams, and William Gee, 23 Middle-street, Cloth Fair, and George Davis, S Bath-street, Newgate-street—Invention for the application of the process of lithographic and zincographic printing of words, patterns, designs, and marks on metal, glass, wood, and other hard and unyielding substances in sheets, slabs, or flat pieces, with or without the intervention of paper or other flexible material.
 2116. Henry Dubs, Vulcan Foundry, near Warrington—Improvements in the method of forging or manufacturing iron and steel.
 2117. Adolphus Sington, Manchester—Certain improvements in machinery or apparatus for grinding or setting doctors, used in calico and other similar printing machinery.—(Communication.)
 2118. Alexander Allan, Crewe, Cheshire—Improvements in locomotive and other boilers for generating steam.
 2119. James H. Dickson, Evelyn-street, Lower-road, Deptford—Improvements in machinery or apparatus for the preparation of flax and similar fibrous material.
 2120. Jacob Behrens, Bradford—Improvements in the manufacture of zinc.—(Communication.)
 2121. William Smith, Little Woolstone, Bucks—Improvements in implements for tilling and preparing land for crops.
 2122. Emerson Goddard, New York—Improvements in machinery for cutting stone.
 2123. Moses Poole, Avenue-road, Regent's-park—Improvements in apparatus and means for removing matters or heat from currents of air, gases, or vapours, or from liquids, and for communicating matters or heat to the same.—(Communication.)
 2124. Richard Laming, Millwall, Poplar—An improved process for purifying gas.

Recorded September 14.

2125. John Wakefield, Dublin, and James Bakerville, same place—Improvements in and applicable to valves, for reciprocating engines driven by steam or other elastic fluids.
 2126. John Wilson, Manchester—Improvements in and applicable to machines for printing fabrics.
 2127. Philip Webley, Birmingham—Improvements in repeating pistols and other fire-arms.
 2128. John Timmis, Stafford—Improvements in safety valves for boilers.
 2129. Alexander Wallace, Glasgow, and George Galloway, same place—Improvements in the construction of portable articles of furniture.
 2130. John J. G. Collins, Philadelphia, U. S.—Certain improvements in steam-engines.
 2131. John H. Johnson, 47 Lincoln's-inn-fields, and Glasgow—Improvements in sewing machines.—(Communication from Mesdames Adrienne Elizabeth Figuiet and Euphrasie Chéran, Paris.)
 2132. James Higgin, Manchester—Improvements in burning certain fluids for the purpose of obtaining heat.
 2133. Charles T. Hook, Tavail House, Maidstone, Kent—Improvements in the manufacture of rulp.
 2134. Richard D. Kay, Bank-terrace, Accrington—Improvements in block-printing.
 2135. Moses Poole, Avenue-road, Regent's-park—Improvements in machinery for separating flour shorts and dustings from bran, as it comes from the bolting apparatus.—(Communication.)
 2136. George Spencer, 6 Cannon-street West—Improvements in supporting rails of railways.
 2137. Jacob Behrens, Bradford—Improvements in generating steam in steam boilers.—(Communication.)
 2138. Thomas Swingle, Litchurch, Derbyshire—Improvements in the permanent way of railways.
 2139. William Nash, Burslem, Staffordshire—An improved mode of manufacturing china and earthenware articles on the lathe.

Recorded September 15.

2140. Charles White, Fimble—Improvements in the blocks for block-printing.
 2141. Eliezer Edwards, Birmingham—A new or improved gas stove.
 2142. Thomas Browning, Pendleton, Lancashire—Improvements in machinery or apparatus for washing, scouring, or cleansing woven fabrics, either with plain or pile surfaces.
 2143. Henry Krant, Zurich, Switzerland—Improvements in tools or implements to be used for boring or cutting rock or other hard substances, for the purpose of blasting.
 2144. Thomas W. Keates, Chatham-place, Blackfriars—Improvements in the distillation of turpentine and other resinous substances, and their products.
 2145. Harvey Hilliard, Glasgow—Improvements in apparatus for cleaning table cutlery.
 2146. Ludwig F. H. C. Knuth, Old Bailey—Improvement in the manufacture of purses, cigar cases, reticules, bags, tobacco-pouches, and other similar articles.
 2147. Henry Jeanneret, Great Titchfield-street—Improvements in machinery for digging and tilling land.
 2148. Moses Poole, Avenue-road, Regent's Park—Improvements in distributing printers' type.—(Communication.)
 2149. Sydney Smith, Hyson Green Works, near Nottingham—Improvements in governors for steam-engines.
 2150. John Barsham, Kingston-upon-Thames—Improvements in the manufacture of bricks, tiles, and blocks.

Recorded September 16.

2151. Francis Higginson, 65 King William-street, London-bridge—Certain improvements in the means of setting in motion and propelling ships, vessels, and boats of every description, upon seas, rivers, canals, and inland waters.
 2152. David Misset, Coleford, Gloucestershire—Improvements in steam-engine boiler and other furnaces.
 2153. William S. Icely, Bromley—Improvements in mechanical telegraphs.
 2154. Henry Meyer, Manchester—Improvements in looms for weaving.
 2155. William Carron, Birmingham—An improvement or improvements in signalling or communicating intelligence.
 2157. Andrew Barclay, Kilmarnock—Improvements in arranging and working mining engines.
 2158. Andrew Barclay, Kilmarnock—Improvements in lubricating shafts or revolving metallic surfaces.
 2159. Alexander Thomson, Glasgow, and David Lockerbie, same place—Improvements in kilns for baking and burning articles in earthenware.
 2160. John Adcock, Marlborough-road, Dalstou—An improved apparatus for measuring the distance travelled by vehicles.
 2161. Baldwin F. Weatherdon, Chancery-lane, and Matthew S. Hooper, Sydenham, Kent—Certain improvements in railway signals.

Recorded September 17.

2162. Thomas E. Lilly, Birmingham—Improvements in certain kinds of carriages.
 2163. Arthur J. Baker, 51 Burton-crescent—Strengthening vessels of timber and iron.
 2164. Jonathan Burton, Crawshaw-Booth, Lancashire—Improvements in shuttles for weaving, the whole or part of which are applicable to skewers used in winding and reeling machines.
 2165. Richard Litherland, Liverpool, and Thomas Pictou, Toxteth Park, near Liverpool—An improved mode of manufacturing brushes, and in machinery for applying the same to the purposes of polishing and cleaning.
 2166. Christopher Nickels, York-road, Lambeth, and Ralph Selby, same place—Improvements in the manufacture of flexible tubes and bands, and in covering wire.
 2167. Henry C. Jennings, S Great Tower-street—Improvements in treating and bleaching resinous substances.
 2168. Baron Henry de Bode, 8 Albert-street, Camden-road—Improvements in the manufacture of wheels.
 2169. Richard A. Brooman, 166 Fleet-street—Improvements in the manufacture of soap and saponaceous compounds.—(Communication.)

Recorded September 19.

2170. Edward Thomas, Belfast—An improvement in the construction of looms for weaving.
 2171. Charles Collins, Hartford, Connecticut, United States—The manufacture by machinery of tubes from leather or other suitable flexible substances, chiefly for covering the drawing rolls of spinning machinery, but also applicable to other purposes.
 2172. William L. Anderson, Norwood, Surrey—Improvements in propelling ships and other vessels.
 2173. John Stephens, Richmond, Surrey—Improvements in obtaining motive power by the aid of air, steam, and other expansive gases.
 2174. Thomas Kestell, Strand—Improvements in opening and closing ventilating louvres.

Recorded September 20.

2175. Samuel Walker, jun., Birmingham—New or improved machinery for manufacturing thimbles.
 2176. Robert Fletcher, Birmingham, and John Smith, same place—Improvements in fire-arms, and discharging the same.
 2177. Henry Walker, Gresham-street—Improvements in the modes or means of stopping or retarding vehicles used on railways.
 2178. John L. Beloud, Samuel C. Beloud, and George Guyatt, Greek-street—Improvements in shears.
 2179. Arvid M. Servan, Philpot-lane—Improvements in distilling fatty and oily matters.
 2180. Moses Poole, Avenue-road, Regent's-park—Improvements in life-preservers.—(Communication.)
 2181. Ferdinand Potts, Birmingham—Improvements in the manufacture of taper tubes, and in the apparatus connected therewith.
 2182. William Stockil, Long-lane, Surrey—A new or improved method of blocking leather used in the manufacture of boots.
 2183. Stephen Neal, Manchester, William B. Jerrold, Inner Temple, and Conrad Montgomery, Cornhill—Improvements in machinery for the manufacture of casks and barrels.—(Communication.)
 2184. Henry Needham, Wardour-street—Improvements in revolving fire-arms.
 2185. Joseph Gibbs, Abingdon-street—Improvements in the treatment of minerals, for the purpose of separating impurities therefrom.

Recorded September 21.

2186. George Peabody, Warrford-court—Improved machinery for dressing and warping yarns.—(Communication.)
 2187. Alfred V. Newton, 66 Chancery-lane—An improved method of forming seams and ornamental stitching, and in machinery for effecting such operation, part of which machinery is applicable to the forming of other seams and stitches.—(Communication.)
 2188. Alfred V. Newton, 66 Chancery-lane—An improved mode of constructing steam-boilers, applicable also in part to the construction of condensers.—(Communication.)

Recorded September 22.

2189. Thomas Smedley, Holywell, Flintshire—An improved railway train signal, communicating to the guard and engine driver.
 2191. Frederick C. Calvert, Manchester—Certain improved processes for separating emery from other matters.
 2192. Peter R. Arrowsmith, Bolton-le-Moors, Lancashire, and James Newhouse, same place—Certain improvements in machines for spinning and doubling.
 2193. Edward Oldfield, Salford—Certain improvements in machinery for spinning and doubling.
 2194. Thomas W. Walker, Hanley, Staffordshire—Certain improvements in the manufacture of crates made of wood for the use of potters.
 2195. George White, 5 Laurence Poultry-lane—An improvement in paddle-wheels.
 2196. Samuel A. Benetink, Cheap-side—An improved construction of coal-box.

Recorded September 23.

2197. James Leech, Birmingham—An improved method of constructing breech loading fire-arms.
 2198. Charles Alexander, 373 Albany-road, Camberwell—A certain manner of preparing marquetry and all other kinds of inlaid work, in veneers of various thicknesses, and for fixing the same to walls and ceilings of whatever kind, and in or upon floors of wood, stone, or metal, and for rendering such floors water and fire proof.

2199. Auguste E. L. Belford, 16 Castle-street, Holborn—Invention of the application of the extract of the pine and other trees of the fir tribe to dyeing and colouring purposes.—(Communication from Nicolas P. Gunion, Lyons.)
2200. Robert Varvill, 30 High-Ousegate, York—An improved mortising machine.
2201. William Dantec, 5 New Quay, Liverpool—Improvements in purifying water.
Recorded September 24.
2202. James G. Jones, Islington—Certain improvements in the means of conveying signals or intelligence from one part of a railway train to another.
2203. Hiram Tucker, Massachusetts, U. S.—A new and useful improvement in the art or process of applying colours to a surface by means of a liquid.
2204. Alexander Dalgety, 76 Florence-road, Deptford—Improvements in lathes.
2205. William Farmer, High-street, Fulham—Improvements in apparatus for preserving provisions.
2206. Charles E. Austin, Rookwoods, Stroud—An improved reaping, gathering, and binding machine.
2207. Charles Maitland, Alloa, Clackmannanshire, and William Gorrie, Rosemains, Cranston, Midlothian—Improvements in apparatus for beating water or other liquids.
Recorded September 26.
2208. James Smith, Law Hill, Perthshire—Improvements in scythes.
2210. Joseph Ellison, London—Improvements in chairs, whereby they are rendered more portable, and can be converted into other useful articles of household furniture.
2211. Henry Winter, Castle-street, Holborn—An improvement in trousers, to supersede the use of braces, which improvement is applicable to other articles of apparel.
2212. William A. Biddell, Great Sutton-street, Middlesex—Improvements in alarms and signals, to be used in or on railways, ships, houses, buildings, plantations, or other places, for the purpose of giving audible or visible signal in cases of danger or alarm.
2213. Francis F. Clossman, 16A Park-lane, Hyde-park, Middlesex—The production and application of certain materials to be employed in the manufacture of textile fabrics, and for other purposes.
Recorded September 27.
2214. Robert Popple, Beverley—Improvements in machinery for slubbing, roving, and spinning cotton and other fibrous substances.
2216. William P. Sharp, Manchester, John Hill, jun., and William Martin, same place—Improvements in machinery for spinning and doubling cotton and other fibrous substances.
2217. Isaac Bury, Lower Mosley-street, Manchester, and William Green, Islington—Improvements in treating, stretching, or finishing textile fabrics, and in machinery or apparatus for effecting the same.
2218. Robert Brisco, Low Mill House, St. Bees, Cumberland, and Peter S. Horsman, St. John's, Beckermat, same county—Certain improvements in the preparation of flax and other vegetable fibrous substances.
Recorded September 28.
2219. Moses Poole, Avenue-road, Regent's-park—Improvements in the manufacture of pulp for paper makers.—(Communication.)
2220. Louis D. Girard, Paris—Certain improvements in hydraulic engines.
2221. John Barsham, Kingston-upon-Thames—Improvements in the manufacture of bricks, tiles, and blocks.
2222. John H. Johnson, 47 Lincoln's-inn-fields, and Glasgow—Improvements in machinery or apparatus for cutting paper.—(Communication from Monsieur Poirier, Paris.)
2223. William Hickson, Carlisle—Improvements in machinery for the manufacture and packing of bread or biscuits.
2224. Joseph F. Van Waesbergh, Lokeren, Belgium—Improved manufacture of artificial vinegar.
2225. William E. Newton, 66 Chancery-lane—Improved machinery for cutting metal or other substances.—(Communication.)
2226. Thomas Askie, Little Britain, London—Improvements in the construction of churns, which improvements are also applicable to other agitating or stirring apparatus.
2227. Jean A. Labat, junior, Bourdeaux, and 16 Castle-street, Holborn—An improved system of stoppering vessels and bottles.
2228. Michel O. B. Lesage, Paris, and 16 Castle-street, Holborn—Certain improvements in hydraulic engines.
Recorded September 29.
2229. John Phillips, Birmingham—Improvements in shaping metals.
2231. Francois J. Raux, Montmartre, France—Improvements in railway brakes.
2232. James Griffiths, Wolverhampton—Certain improvements in steam engines.
2233. Thomas W. Kennard, Duke-street, Adelphi—Improvements in constructing piers and foundations under water.
2234. Hiram Berdan, New York, now of Cornhill, London—Invention of a machine for collecting, preserving, and thereby preventing the loss of mercury, in the process of amalgamating metals, and for the more perfect and economical washing, separating, and amalgamating of auriferous and other ores.
Recorded September 30.
2235. Peter A. le Comte de Fontaine Moreau, 4 South-street, Finsbury, and Paris—Improvements in treating certain exotic plants for the production of a fibrous substance, known in commerce by the name of vegetable silk.—(Communication.)
2236. James Willis, Wallingford, Berks—Improvements in gig barns.
2237. John H. Johnson, 47 Lincoln's-inn-fields, and Glasgow—Improvements in apparatus for blowing out ropes or lines, for the better preservation of life and property.—(Communication from Mons. D'Houdetot, Havre.)
2238. John Plant, Beswick, Lancashire—Improvements in the manufacture of textile fabrics.
2239. Robert Brisco, Low Mill House, St. Bees, Cumberland, and Peter S. Horsman, St. John's, Beckermat, same county—Certain improvements in machinery for heckling flax, hemp, China grass, and other fibrous substances.
2240. John Taylor, Princes-square, Middlesex—An improvement in the treatment or preparation of skins.—(Communication.)
Recorded October 1.
2243. John Summerscales, and Benjamin Bancroft, Keighley, York—Improvements in shuttles employed in weaving textile fabrics.
2245. Thomas Woodcock, Pultney-terrace, Islington—Improved machinery for carving, cutting, chiselling, and engraving.
2247. Jean M. Letestu, Paris—Certain improvements in propelling ships and vessels.
2249. Isaac Ambler, Manningham, near Bradford, York—Improvements in preparing or combing wool and other fibrous substances.
2251. Robert Halliwell, Bolton-le-Moors, and William Johnson, Farnworth, Lancaster—Improvements in machinery for spinning and doubling cotton and other fibrous substances and for grinding-cards.
Recorded October 3.
2253. Michael Dwyer, Unity-place, Samuel-street, Woolwich, Kent, and James Brown, 2 Bridge-terrace, Mile-end, Middlesex—An improvement in anchors.

2255. William J. Thomson, North Shields—Improvements in heating reverberatory and other furnaces.—(Communication.)
2257. James Leadbetter, and William Wright, Halifax, York—Improvements in machinery or apparatus for raising fluid and solid substances.
2259. Alfred S. Jee, 6 Jobn-street, Adelphi—Improvements in the construction of rails for railways.
Recorded October 4.

2261. Peter R. Jackson, Salford, Lancaster—Improvements in machinery for manufacturing hoops and wheels.
2263. Henry J. Jordan, Berners-street, Middlesex—An improved medicine for the cure of venereal affections, which he denominates "the Trieste-mar."—(Communication.)
2265. Nevill Crofts, Derby-terrace, Nottingham-park—Improvements in weaving.
2267. Nevill Smart, Merton, Surrey—Improvements in the manufacture of bricks.
2269. William Gossage, Widnes, Lancaster—Improvements in obtaining certain saline compounds from solutions containing such compounds.
Recorded October 5.
2271. Joseph Holmes, Portsea, Hampshire—Improvements in soldiers' or mess canteens and other articles for containing food.
2273. John Wright, Rochester, Kent—Improvements in apparatus to facilitate the landing and embarking of passengers from steam boats, and other vessels.
2275. Henry J. Betjemain, New Oxford-street, Middlesex—Improvements in apparatus for fixing capsules on the necks of bottles, and other vessels.
2277. Samuel L. Worth, 293 Oxford-street, and Agmond D. V. Canavan, Fitzroy-street—An improved polishing and brightening surface.
2279. John Mason, Rochdale, Lancaster—Improvements in preparing cotton for spinning and in machinery or apparatus for effecting the same.
Recorded October 6.

2281. John Milner, Stratford, Essex—Improvements in steam-engines.
2283. Joseph H. Cary, Norwich—An improved pianoforte action for upright pianofortes.
2285. Manuel Fernandez de Castro, Madrid—Improved means of preventing accidents on railways.
2287. Henry Goddard, Castle Gate, Nottingham—Improvements in stoves and kitchen ranges.
2289. John Rubery, Birmingham—Improvements in the manufacture of umbrella and parasol furniture.—(Communication.)
Recorded October 7.

2291. George Ellins, Droitwich, Worcestershire—New or improved machinery for thrashing or separating the stem and husk from the grain or seed of wheat, barley, flax, and other plants.
2293. James Bullough, Accrington, Lancashire, John Walmesley and David Whittaker, Blackburn, same county—Improvements in machinery or apparatus for warping and sizing, or otherwise preparing, yarns or warps to be woven.

Information as to any of these applications, and their progress, may be had on application to the Editor of this Journal.

DESIGNS FOR ARTICLES OF UTILITY.

Registered from 22d Sept., 1853, to 6th Oct., 1853.

Sept.	22d,	3512	Thomas Cowburn, Bolton-le-moors,—“Oscillating safety-valve.”
	23d,	3513	William Collimore, Brighton,—“Crotchet Cotton Reel-holder.”
Oct.	24th,	3514	Thomas Brindley, Finsbury,—“Spring Bible and Prayer-case.”
	26th,	3515	Joseph Chant, Bridgewater,—“Rib or tooth of crushing-roller.”
	28th,	3516	James Barlow, King William-street,—“Cinder-sifter.”
	1st,	3517	James Mellor, Macclesfield,—“A stock.”
6th,	3518	James Mellor, Macclesfield,—“Cravat.”	
	3519	F. L. Bauwens, Pimlico,—“Lamp candlestick.”	

DESIGNS FOR ARTICLES OF UTILITY.

Provisionally Registered from 1st August, 1853, to 20th Sept., 1853.

August	1st,	525	John Bentham, Chorley, Lancashire,—“Segment spring light.”
	8th,	526	Duncan Sinclair, Oxford-street, and John Masson, Cbapel-place,—“Rudder and steering apparatus.”
11th,	527	S. G. Pape, Camden-town,—“Drawers.”	
	528	S. G. Pape, Camden-town,—“Trousers.”	
Sept.	15th,	529	William Collimore, Brighton,—“Crotchet cotton reel-holder.”
	16th,	530	Alfred Somerville, Birmingham,—“Regulating-pen and holder.”
	17th,	531	S. G. Pape, Camden-town,—“Under vest.”
	—	532	Robert Aitchison, Holloway,—“Winding-machine.”
20th,	533	Thomas Brindley, Finsbury,—“Spring Bible and Prayer-case.”	

TO READERS AND CORRESPONDENTS.

A SUBSCRIBER, Liverpool.—Mr. W. Aspdin has just specified a patent for “the manufacture of Portland and other cements from alkaline waste.”

W. S.—We cannot understand his proposition very well; but we may as well inform him at once that his aim is quite hopeless.

A Correspondent wishes to know “What is the best purpose to which charcoal dust can be put, and the process it has to undergo?”

H. C., Langton Cottage.—We have not been able to reply to this note, in consequence of no further address being given us.

W. G. E.—We shall have some notes on this next month.

F. R. S. (*Practical Draughtsman*).—As to the first question—Where the constant number 52.5 comes from—we have simply to refer to the page preceding that so voluminously quoted, paragraph 333. The rule will obviously apply to all diameters, but a little more must be allowed for friction in small pumps. As to the second remark, if Mr. S. had gone over the calculation, he would have seen that the result, “5 feet 6 inches,” was a mere typographical error; for the term $\sqrt{\frac{.225}{6 \times 15}}$ obviously equals 6 inches only.

This will be duly noticed in the “*Errata*,” on completing the work. Also, for “a minimum of 50 feet, and a maximum of 80 feet per second,” in page 108, paragraph 334, read, “per minute.”

J. P., New York.—The papers are published in the Transactions of the Institute. If our correspondent cannot meet with them elsewhere, we shall be glad to send him a spare copy of our own.

RECEIVED.—“Report of the Health Committee of the Borough of Liverpool,” by James Newlands, C.E.—“Palmer's Patent Thrashing Company,”—“Industrial Drawing,” by D. H. Mahan.—“A Rudimentary Treatise on Fuel,” by T. S. Prideaux.—“On the Safety Lamp,” by T. Y. Hall.—“Potatoes grown from Peels.”—“The Decimal Coinage,” by A. Milward, Esq.

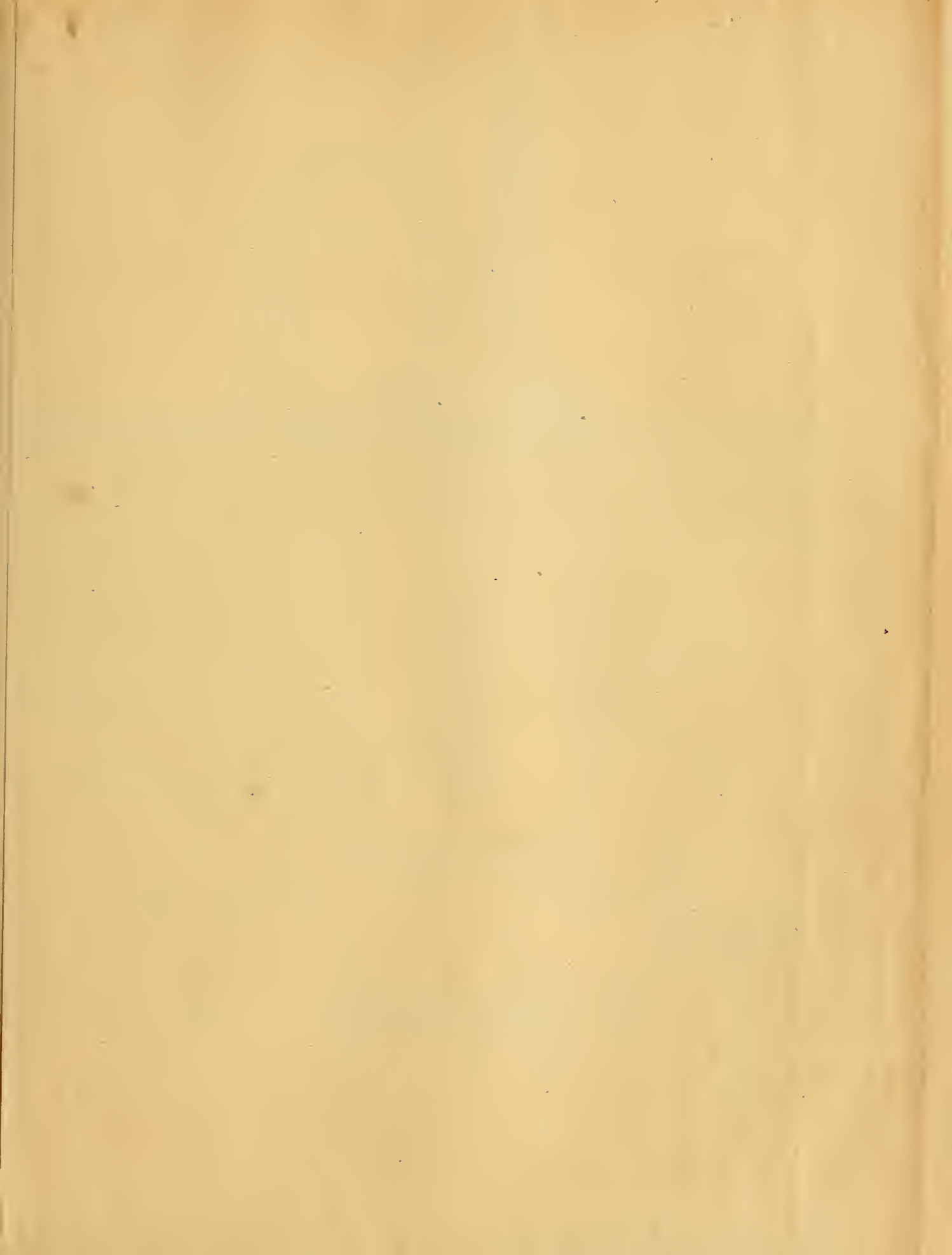

LONDON & NORTH WESTERN EXPRESS LOCOMOTIVE.

J. E. McCONNELL, PATENTEE, WOLVERTON.

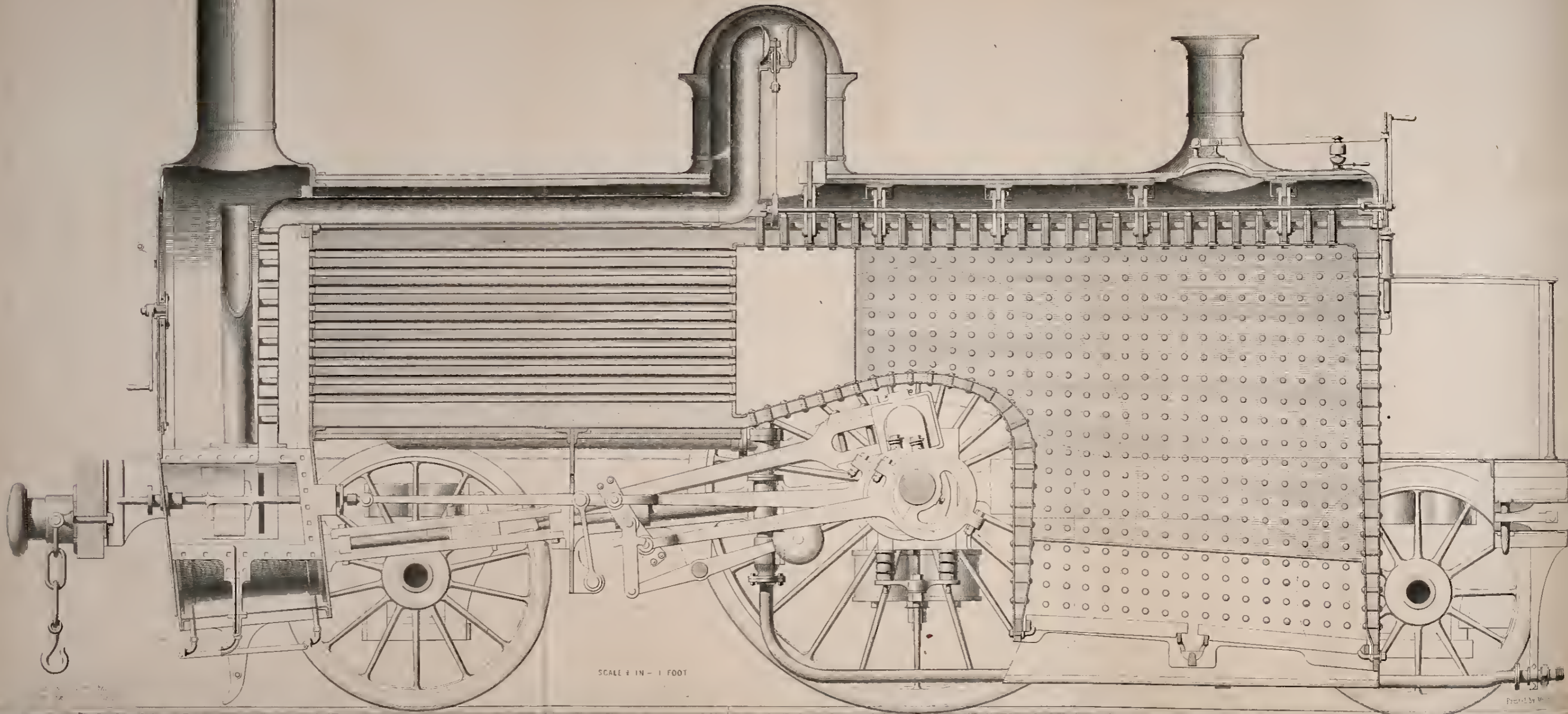

SCALE 3/4 IN - 1 FOOT

Printed by W. & A. G. & Co. Manchester



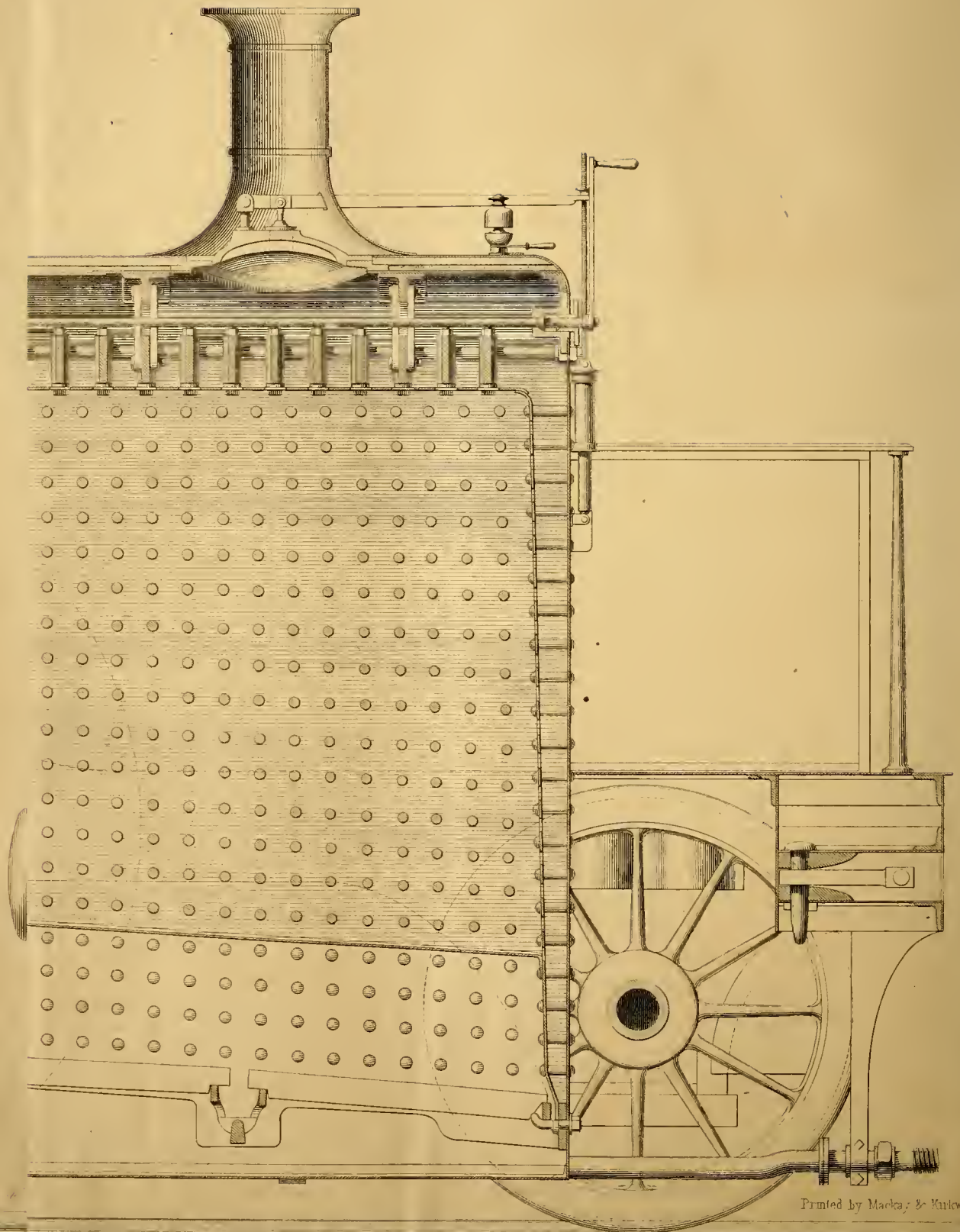

M'CONNELL'S EXPRESS LOCOMOTIVE ON THE LONDON AND NORTH-WESTERN RAILWAY.

(Illustrated by Plates 112, 138, 139, and 140.)

"Though animal organization is beyond the constructive skill of man, he takes the elements existing in nature, and, by new combinations, gets new power. He discovers in his raw materials unexpected properties, until soda and sand are converted into a crystal palace, and water, coal, and stony ore, into a train which rushes with the might of an earthquake, and the velocity of the wind. He devises fresh applications of machinery, and, in the creations of his ingenuity, finds a servant and a master."—*Quarterly Review*.



THE longitudinal section, Plate 140, completes our series of four engravings of this fine locomotive—and furnishes, in itself, a very clear idea of the essential features of peculiarity which Mr. M'Connell has combined in arranging what may fairly be termed a first-class express engine.

The specification which accompanied the elevation, in Part LVII. of this *Journal*,

has already supplied an outline of the general construction of the engine. But the sectional view now before us, brings out more strikingly the several points of the extraordinary extension of the inside fire-box into the harrel of the boiler—together with its great central water-space, or mid-feather; the upward recessing of the boiler's barrel and the corresponding curvature of the inside box for the play of the cranks; the short flue-tubes, comprehended between this forward or extended fire-box tube-plate, and the smoke-box; the steam-beating chest in the smoke-box, for drying the steam on its way from the steam dome to the cylinders; with Mr. Coleman's india-rubber block springs, and the tubular leading and trailing axles.

The inside fire-box projects 4 feet 9 inches into the barrel of the boiler; but the mid-feather stops 2 feet short of this distance, leaving an undivided "combustion chamber," or mixing space, for the gases, preparatory to their entering the tubes in the barrel. This gives 260 square feet of direct heating surface in the fire-box, which area, added to that of the 303 flue-tubes, which are 7 feet in length and $1\frac{3}{4}$ inch in diameter, makes 1,200 square feet as the entire heating surface of the boiler.

The pistons are of wrought-iron, the body being forged in one piece with the rod; and in this way, one-third of the usual weight is saved.

The only other point of importance which we have not hitherto detailed is, the smoke-box heater, for drying the steam prior to its passage into the cylinders. For this purpose, a flat steam chamber is fitted into the smoke-box, so as to stand a short distance clear of the tube-plate. This chamber forms the conducting-pipe for the steam from the collecting dome to the valve-chests of the cylinders; and as it is stayed across by tubular stays, corresponding to the boiler tubes, it follows that the heated air and gases from the latter pass through the chamber tubes on entering the smoke-box. Besides this, as the chamber is enveloped in the heat of the smoke-box, what would otherwise be waste is economically employed in drying the steam.

The hollow axles, as now made in large quantities by the Patent Shaft and Axletree Company, are made from a set of segmental bars, rolled with over-lapping angles, so that, when built together ready for welding, they form a complete cylinder, about $1\frac{1}{2}$ times the finished diameter. This cylinder of loose bars is temporarily held and kept in its tubular form by a screw clip, and each end being put into the furnace, a partial weld is produced, and the clip is then removed. The entire tube is then placed in the furnace, and when at a welding-heat it is passed through a series of rollers, each provided with a fixed egg-shaped mandril. The rolls are arranged with reversing clutches, so that, as soon as the axle-tube has

been drawn clear through, the motion is reversed, and the axle, which has been drawn on to the mandril-rod, is again drawn back through the same roll opening. In this way a diminishing set of rolls brings the tube down to the right size, and it is then taken to a hammer and planished between semicircular swages over its entire surface. During this operation, a jet of water is made to play upon it, enabling the workman to detect any unsoundness in the welding, by the unerring test of inequality of colour. From the hammer the tube is passed to the circular saws, where it is cut to the proper gauge of length, and the end journals are finally formed upon it by heating and hammering upon an internal mandril. The journals may also be made by rolling between two tables, or by two sets of three rollers, running vertically, and set to nip the tube at the necessary distance from shoulder to shoulder.

In illustration of the saving in dead weight, secured by the adoption of tubular axles, let us suppose a railway to have upon it 15,000 carriages and waggons, each running an average yearly distance of 10,000 miles. The actual reduction in weight, per vehicle, taking the two solid axles at 5 cwt., would be $1\frac{1}{2}$ cwt. with the hollow axles; and this, taken over one mile per annum of the given stock, would be 11,250,000 tons. Then, assuming the cost of locomotive power to be $\frac{1}{4}$ d. per ton per mile, we have a saving of £11,700 per annum on this direct head alone.

In testing the comparative strength of the hollow and solid axles, as regards their resistance to transverse strain, the hollow axles have come out peculiarly triumphant. Each axle was supported on heavy cast-iron blocks, 4 feet 11 inches apart, representing the ordinary rail support. A cast-iron block, weighing 18 cwt., was then let fall on the centre of the axle, from a height of 12 feet, when the extent of bend was measured. The axle was then turned half round, to give a similar blow on the opposite side, to bend it in the reverse direction. Under this treatment, a three years' old solid axle, $3\frac{3}{4}$ inches in diameter at the centre, and $4\frac{1}{4}$ inches at the ends, was bent $8\frac{3}{4}$ inches by the first blow—was nearly straightened by the second or reverse blow—bent 10 inches at the third—and was broken square across at the centre by the sixth blow. A new solid axle, of the same dimensions, was bent $9\frac{3}{4}$ inches by the first blow, and broke close to the centre at the fifth blow. A new hollow axle, $4\frac{1}{8}$ inches in diameter throughout, was bent 5 inches by the first blow, then nearly straightened by the second, and was bent 5 inches again by the third. The ninth bent it $4\frac{1}{2}$ inches, and the tenth only $1\frac{3}{8}$. Up to the fifteenth, it was bent alternately to distances varying from 2 to $3\frac{1}{2}$ inches. It stood unbent up to the 29th blow, when it was fractured two-thirds through, and bent $9\frac{1}{2}$ inches. The practical working of these tubular axles, as shown in the express engines, as well as on various other lines of railway, has been most successful in every respect. The same may be said of Mr. Coleman's india-rubber springs, which are remarkable for their lightness, durability, ease of working, and compactness.

To secure all the contemplated advantages of engines like these, we must remodel our permanent ways. As the road exists at present, it is simply impossible to run the London and Birmingham two hours' expresses with any reasonable degree of safety. Hence the operations of the new engines have so far been confined to the ordinary work of the line, in which their performances with heavy trains have been remarkably successful. When tried against the two best engines of the northern division of the line, *Heron* and *Prince of Wales*—long tube boilers—this engine, No. 300, took its load of 34 carriages at an average rate of 36.39 miles per hour, attaining 54 miles per hour at its greatest speed. The two opposition engines, working together, and having 30 per cent. more heating surface, and 42 per cent. more tractive power, attained an average speed of no more than 34 miles per hour, with a maximum of 48 miles, the combined consumption of fuel being three pounds per mile more than that of No. 300.

The express engine weighs 28 tons empty, and about 31 tons with coke and water. The 2,000 gallons of water, and the two tons of coke, which the tender carries, are sufficient for a 60 miles journey.

BOOTH'S PLAITING AND BRAIDING MACHINE.

This ingenious machine is the recently patented invention of Messrs. Adam and John Booth, the machinists of Manchester, who have so modified the original plaiting and braiding machine, as to make it appli-

cable for the manufacture of strong webs of material suitable for door or floor mats. The stout webs produced in this way consist of several strands or cords of hemp, plaited or braided together, like the common plain or fancy braid. But, to make it stouter and more durable, so as to meet the heavy wear to which matting is subjected, Messrs. Booth intro-

Fig. 1.

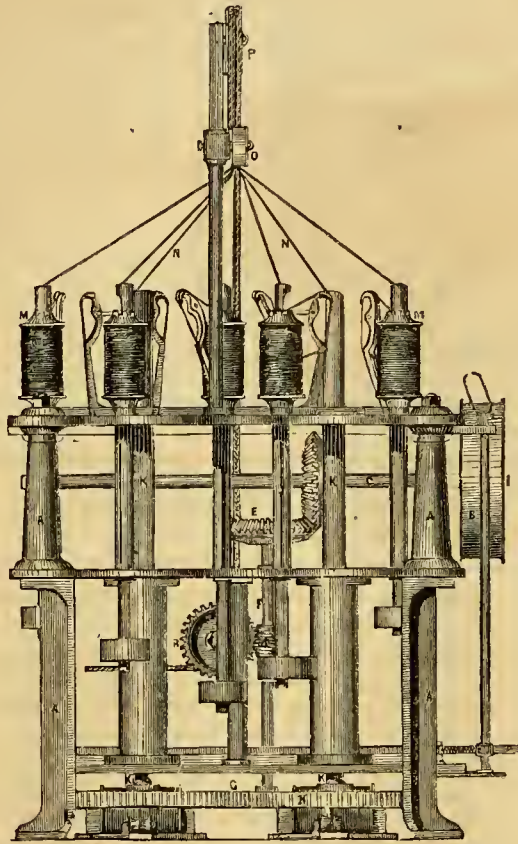
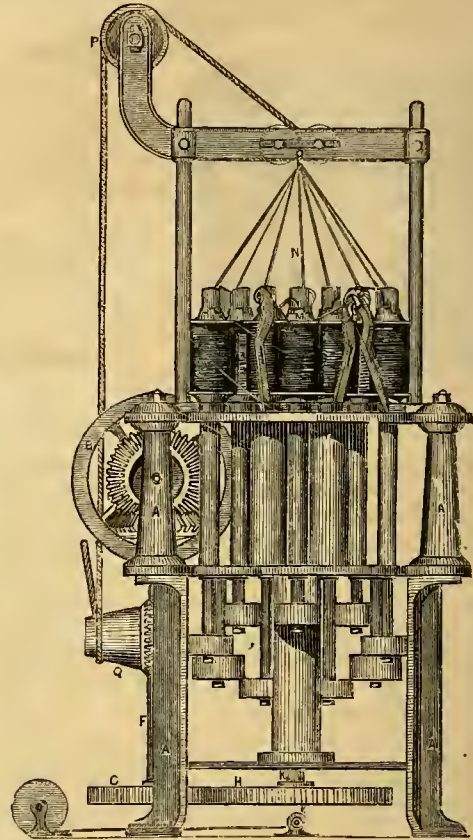

Fig. 2.



duce one or more additional strong cords or strands inside the plaited strands, thus materially strengthening each separate web. The common braiding apparatus cannot effect this, nor can it work such strong

two vertical tubes, to permit the additional strands to pass through them, whilst the ordinary braiding actions are going on.

Fig. 3.

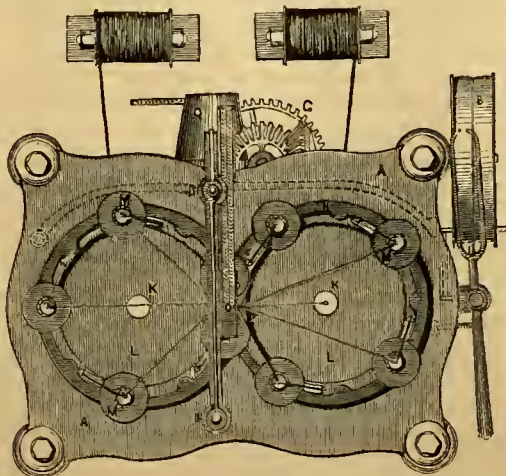
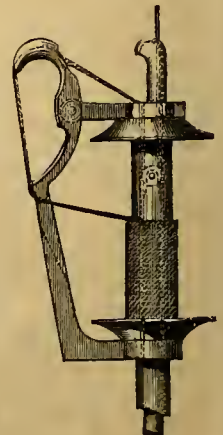

Fig. 1 represents a front elevation of the improved machine. Fig. 2 is a side view of the same. Fig. 3 is a plan; and fig. 4 is a view of a flyer and spindle, such as are usually employed for braiding and plaiting, but on an enlarged scale, and altered to meet the present requirements. A is the framing, and b are the pulleys which drive the shaft, c, on which is keyed the bevil-wheel, d, turning the bevil-wheel, e, upon the vertical shaft, f. At the bottom of this shaft, f, is the spur-wheel, g, working into the spur-wheel, h, which turns a similar wheel, i. These two latter wheels are keyed upon the tubular spindles, k. L are the roses or discs, which carry the spindles and flyers, m, the strands from which, as well as the strengthening guts or cords, n, are passed between the pulleys, o, constituting the resistance to the torsion of the strands and webs when the roses are turned, and thus forming the braid, which is then carried from the pulleys, o, over the guide-pulley, p, and over the conical drum, q, driven by means of the worm-wheel, r, and worm, s, on the vertical shaft, f. The whole of the movements are derived from the fast and loose pulleys, the strap fork of which, together with the starting lever, is represented in figs. 1 and 2.

Fig. 4.



fabrics as these mattings. To accomplish these points, the patentees make the spindles of the roses, or revolving discs, tubular, introducing

The ordinary braiding operation, as uninfluenced by Messrs. Booth's modifications, is clearly delineated in the figures.

MOFFITT'S AMERICAN THRASHING MACHINE.

One of the most important of the industrial curiosities in the New York Exhibition, which we have promised ourselves the pleasure of

noticing at some length, is a thrashing machine invented by Mr. John R. Moffitt, of Piqua, Ohio, U.S., and since brought to this country by the patentee and his partner, Mr. E. H. Knight, of Cincinnati. Our engraving represents the machine, or "grain separator," as the Americans not inaptly term it, in longitudinal section. It consists of an irregular timber framing, *A*, having at one end the usual inclined feed-opening, *B*,

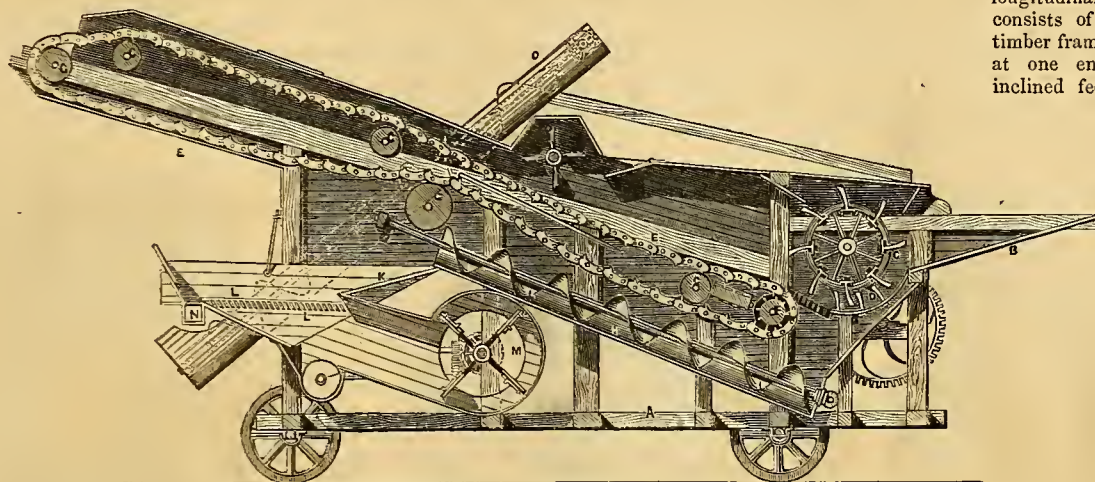

for the reception of the unthrashed grain to be operated upon. As the grain is fed in here, the straw is caught by the thrashing cylinder—the teeth, *c*, of which act in concert with similar teeth on the interior corresponding surface of the concave portion, *d*, of the casing. From the sphere of this cylinder, or thrashing drum, the straw is delivered on to an endless travelling apron or carrier, *e*. This carrier is slightly inclined from the horizontal, and as it conveys the straw upwards and onwards, its open bars allow of the loosened grain and chaff to fall down into the well of the machine; and for this purpose, part of the concave case, *n*, is open-barred as a separating platform. The carrier is composed of wooden rods, connected by the metal links represented in our figure, and the peculiar motion imparted to it materially assists the separating operation. This straw-carrier is actuated by a pinion or spoked cylinder, *f*, gearing with catches on the inner side of the metal links of the straw-carrier; and it runs over fixed guide-rollers, *g*, against which the inner catches of the metal links come in contact during the traverse motion. It is the striking action of the catches upon these rollers which gives the necessary shaking action to the carrier, for the separation of whatever grain and chaff may be carried over along with the straw. The grain and chaff pass from the thrashing cylinder and the shaker into the well, *n*, of the machine, whence they are conveyed by the revolving screw traveser, *j*, down the board, *k*, into the "slat" riddle, *l*, which is formed like a partially-closed Venetian blind. The grain itself passes through this riddle, and all the refuse is blown over beyond it by the blast of the fan, *m*. The grain is finally discharged at either side of the machine at pleasure. Any imperfectly thrashed matters are collected in a trough, *x*, at the end of the shaking shoe, and are conveyed upwards and backwards by a screw, *o*, and ultimately thrown into the feed-opening of the thrasher for secondary treatment.

Whilst the work performed by this machine amounts to the largest quantity that can be handled by one gang of men, it is remarkable for two essential points—the thorough separation of the grain and chaff from the straw, and the subsequent cleanly separation of the grain from the chaff. This machine, which has lately been in operation on Mr. Mechi's farm, Tiptree Hall, Essex, was driven by a steam-power of four horses; and it thrashed a stack of 32 quarters, or 256 bushels of wheat in four hours—cleaning the grain in perfect readiness for market. When afterwards tried upon barley, it thrashed 56 quarters, or 448 bushels in six hours, the grain being turned out clean and ready for malting, or sale.

When in operation at Tiptree, it was visited by a large number of farmers and machinists, who were surprised to find that it did not break or injure the grain—for out of the 56 quarters of barley, not a grain seemed to be divided. Five farmers who were present at the trial purchased their seed-wheat from the machine. Mr. Mechi himself states, that the barley thrashed by it, although grown on poor land, sold for 45s. a quarter for malting; and he adds, that ten quarters were turned out by it in seventy-three minutes—that its powers outstrip all the exertions of the feeders—and that, by enlarging it and quadrupling its

attendants, thirty or forty quarters might be thrashed by it within the hour.

It weighs $12\frac{1}{2}$ cwt. without its wheels and driving gear, and can be made in America for £23.

THE LAW AS TO PATENTS FOR INVENTIONS
IN BAVARIA.

The law in Bavaria Proper is regulated by a royal ordinance, bearing date the 10th of February, 1842; and in that part of the kingdom known as the Palatinate and Rhenish Bavaria, it is regulated by certain French decrees of 1790 and 1791. First, as to Bavaria Proper:—

Patents will be granted for discoveries, inventions, or improvements in trade, whether such be a new manufactured article, or a new instrument of manufacture, or a new process, provided that (1.) the invention or improvement is new and original, and (2.) is of such importance as to promise being of general utility. Patents for imported inventions or improvements will be granted when new and original, and when a patent has been procured in the country whence the invention or improvement has been brought; but a Bavarian patent for an imported invention will expire at the same time as the patent in the foreign country.

When, after the grant of a patent, it appears that the invention is without novelty and originality, or has been described in published works, either German or foreign, in such a way that competent persons might carry it into effect, the patent will be rendered void.

Persons desiring to obtain patents must present a petition to the Minister for the Home Department, and must therein distinctly state the petitioner's name, profession, dwelling, and legal domicile, the general features of the invention or improvement in its essentials, and whether he requires an exclusive right for the manufacture of an article, or for the application of new machinery, or for the application of a new process; lastly, the length of time for which he demands a patent. A full and exact description of the invention or improvement, and of the mode in which it is to be carried into effect, must accompany the petition; and, when necessary, drawings, models, or patterns must be annexed. It must be stated, in clear and precise terms, what part of the invention is claimed as new and original. In case of an imported invention, either the original patent, or an authenticated copy, must accompany the petition.

Patents will be refused, if it shall appear that the invention cannot be carried into effect without injury to the public health and safety, or without danger to the commonweal, or without infringing the law. They will also be refused if the pretended invention is not new and original; also if a patent for the same invention has been previously granted in Bavaria; also if a patent for the invention has been obtained in some other of the states of the Zollverein, and the applicant in Bavaria is not the inventor or his representative.

The utmost term for which a patent will be granted is fifteen years;

if granted in the first instance for a shorter period, it may be prolonged until the full term of fifteen years is complete.

A patent confers no power of preventing the importation of objects of a kind similar to those patented, or the sale of such imported objects, nor even the use of similar objects not obtained from or with the consent of the patentee, except in the case of patents for new processes of manufacture, or for new articles, or for new manufacturing machines.

A patentee of an improvement will not be allowed to prejudice the holder of a previous patent. A patentee has the power of transferring his interest to another person, and, in case of the patentee's death, his rights pass to his heirs. Priority of application for a patent will determine the right to it, when several persons make application about the same time.

A patent will be void if it should appear that there were circumstances existing at the time of the grant which would have prevented its issuing—if it should appear that the patented invention is not new and original, or has been previously publicly known (except in the case of its having been known to a few persons only, and then it will be in full force as against all other persons)—if any essential part of the invention or improvement was not described—or if the patentee should make no use of the invention within three years, or, the patent being granted for less than six years, if he should make no use of the invention within the first half of that period—or, being a patent for an imported invention, if he should make no use of the invention within one year—if the patentee should suspend the execution of the patented invention for two consecutive years. A patent for an imported invention will be void as soon as the patent in the foreign country expires.

A register of patents is ordered to be kept, which may be consulted by all persons interested. After the expiration of a patent, the description of the invention will be published by the Government, if deemed useful to the commercial interests of the country.

The Government charges upon a patent depend upon the number of years for which it is granted. On a patent for one year, they amount to 5 florins (about 10s. 6d.); 2 years, 10 florins; 3 years, 15 florins; 4 years, 20 florins; 5 years, 25 florins; 6 years, 35 florins; 7 years, 45 florins; 8 years, 55 florins; 9 years, 65 florins; 10 years, 75 florins; 11 years, 95 florins; 12 years, 125 florins; 13 years, 165 florins; 14 years, 205 florins; 15 years, 275 florins.

The French decrees, which declare the law as to patents in the Palatinate and Rhenish Bavaria, were issued at a time when these districts were in the power of France. They have never been abolished, and still remain in force. They are to the following effect:—

The applicant for a patent must forward to the office of the secretary of his department a statement of his claim, and whether he claims in respect of an original or an imported invention or improvement; and he must deposit, under seal, an exact description of the principles, methods, and processes of which the discovery consists, accompanied, if necessary, by drawings and models. Patents are granted for five, ten, or fifteen years, at the option of the patentee; the last-mentioned term cannot be extended, except by a legislative decree. Patents for imported inventions will not be valid after the expiration of the patent in the country from which they are brought.

A patentee may either work the patent himself, or license others to carry it into execution. Patents are transferable like other personal property.

Patents will become invalid, if the inventor, in describing the invention, conceals the true method of carrying it into effect, or if he shall use in his own manufactory processes which he has not described, or if the invention had been previously described in printed and published books, or if the inventor shall fail to carry his invention into effect within two years from the date of his patent, there being no good reason for the

delay. At the expiration of a patent, or in case of its invalidity, the inventor's description will be made public, and the invention will be free to every one.

Only one principal object can be included in a single patent. Mere changes of form or proportion, and ornaments, are not patentable inventions.

MESSRS. WILLIAMSON'S DOUBLE-ACTION TURNIP-CUTTER.

This very efficient turnip-cutter—a modified improvement upon the original invention of Mr. Gardner of Banbury—is the production of

Fig. 1.

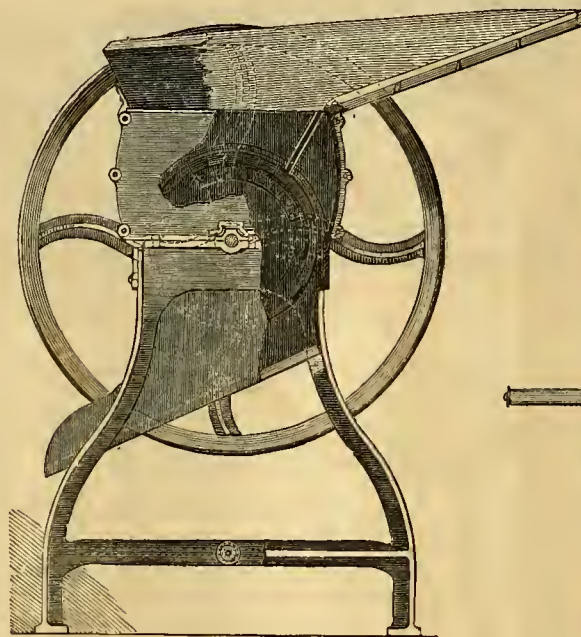
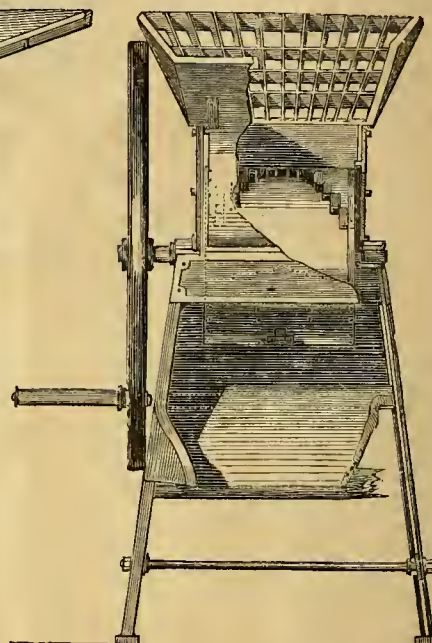

Fig. 3.



Messrs. Williamson, Brothers, of Stainton Mills, Kendal. It involves the use of two classes of reducing knives or cutters, one being adapted for slicing roots for cattle, and the other for cutting them into small pieces suitable for feeding sheep. Fig. 1 of our engravings is a side elevation of the machine, with the cutting details in partial section; fig. 2 is a longitudinal section of the cutting cylinder detached; and fig. 3 is a front elevation at right angles to fig. 1, with a part of the feed-bopper broken away.

The cutting knives project from the surface of a cast-iron cylinder fast on a horizontal spindle, running in end bearings on the top of a rectangular cast-iron frame, and actuated by a winch-handle on one end; or, when horse, steam, or water power is available, this handle is replaced by a small hand-pulley. A portion of the arc of the cylinder, behind each individual cutting edge, is removed, so that, as the pieces of turnip are severed, they pass into the interior of the cylinder, and thence fall away down the discharging shoot, in front of the machine, to the proper receptacle for them.

Fig. 2.

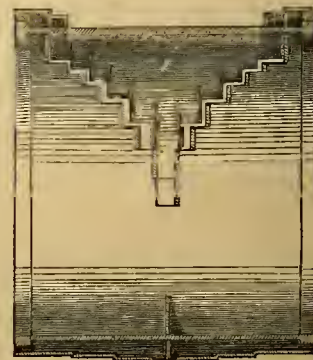

There are two sets of each sort of knives fixed opposite to each other; the slicing knives fronting in one direction, and the strip knives—which there are fifteen in each set—in the other. The former are brought into action by the left-hand, and the latter by the right-hand motion of the driving-handle. As delineated in our illustrated figures, the small knives are disposed angularly upon the cylinder; and the slicing knives are also so shaped, that, by coming gradually into operation, they prevent all risk of the unequal working strain which would arise if they were fixed in one line. The turnips are fed into the

machine by an overhead hopper, grated, to allow stones and dirt to fall through. From this hopper the roots roll on to the cylinder, and are rapidly cut by the revolving knives, the strips severed by the small knives being $\frac{3}{8}$ by $\frac{1}{2}$ inch, and the slices produced by the reverse action being $\frac{5}{8}$ inch thick. The framing is composed of a couple of plain open cast-iron standards, stayed across by tie-rods, and bound together as well at the top; and the front plate is so curved as to give the least possible extent of play to the roots whilst they are under the knives, otherwise the

cut would be jagged and uneven, and would consume a much greater working power. In the larger scale, fig. 2, the section through the cylinder shell shows the shape of the strip knives and the flanges to which they are fixed, as well as an external sheet of iron, used to steady and support them when working. A slide is placed below the hopper to guide the turnips to the forward side of the cylinder. The general arrangement and workmanship are extremely creditable to the makers.

THE IRISH ENGINEERING COMPANY'S PORTABLE STEAM-ENGINE.

Fig. 1.

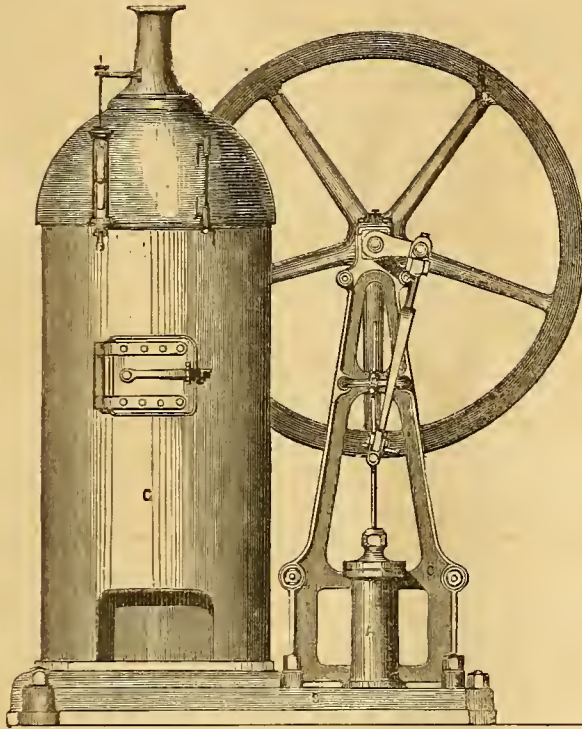

This "vertical, direct-acting, portable, high-pressure steam-engine and boiler, complete in one bed-plate" — as described in the Dublin Exhibition Catalogue, — was erected in the Exhibition Buildings, for driving the *Exhibition Expositor* printing-machine. We represent the engine, in fig. 1, in full front view, with its boiler attached alongside; and in fig. 2, in corresponding side elevation, showing the boiler behind the engine. The engine cylinder, A, $4\frac{1}{2}$ inches diameter, and 12 inches stroke, is bolted down erect upon the side of the plain base-plate, B, and in front of the pair of vertical standards, C. These

standards are open inclined frame-pieces, bound together transversely by tie-rods, and carrying hearings at their upper ends, for the reception of the crank-shaft, D, on the overhanging end of which is the fly-wheel, E.

Fig. 2.

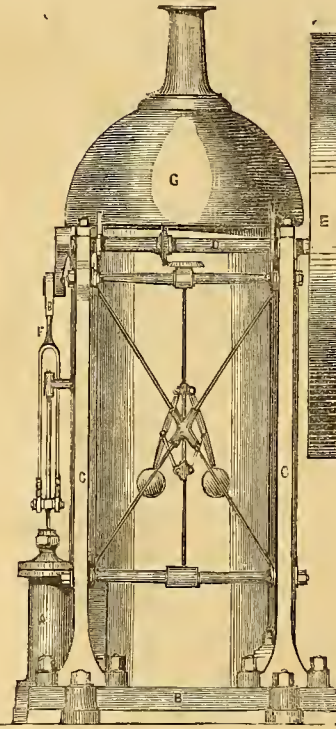

The cylinder stuffing-box gland is screwed into the cover, without bolts, and the piston-rod works through this direct to the crank above, through the intervention of a forked connecting-rod, F, jointed by a cross pin to the piston-rod, which is guided by a bracket on the frontstandard. The governor is conveniently placed in the centre of the space between the two standards, and directly beneath the axial line of the shaft, D, from which it is driven by a pair of bevil pinions. The boiler, G, is of the vertical tubular kind, with a hemispherical top. The arrangement altogether is well adapted for fixed work in agricultural and manu-

facturing operations where space is limited, as the base-plate measures only 5 feet 3 inches \times 3 feet 6 inches. It is the production of the Company's Works in Seville Street, Dublin, and is creditably made.

BRITISH AND AMERICAN LINES OF STEAMERS.

The following forms part of an article which appeared a short time since in the *Revue des Deux Mondes*, the leading literary periodical of Paris:—

Wherever human activity extends, Great Britain and the United States are creating lines of steam-boats, by which the means of intercourse are multiplied and rendered easy, regular, and rapid. The Atlantic, the South Sea, the Indian Ocean, the Australian seas, are ploughed in every direction by these wonderful vessels, which brave all obstacles—currents, winds, hurricanes, and calms. The paddles of the French steamers visit, as yet, but the waves of the Mediterranean.

The English and American steamers of the present day traverse the waters of the Atlantic and Pacific oceans, the Mediterranean and the Indian seas. The different lines are conducted by several powerful companies, possessing large capitals, and assisted by contributions from the state.

In the month of April, 1838, the *Great Western* and the *Sirius*, the first steamers which ventured to cross the Atlantic, quitted Bristol and Cork. The *Great Western* found but seven passengers courageous enough to accompany her. Towards the end of 1838, the English Government took measures for establishing regular communication between the United States and England, and concluded with Mr. Cunard an arrangement, by which it was stipulated that he should provide a bi-monthly transit between Liverpool and Halifax, in consideration of an annual payment of £45,000. Four steamers, of 1200 tons burden, and

400 horse power, were provided, and the line was opened in 1840. In 1849, by a new agreement, a departure of steamers to Boston or New York was organized, weekly, except during the four winter months, when the departures were to be only bi-monthly; and the annual payment was increased to £145,000. The old vessels were replaced by others of from 1800 to 2000 tons burden, and from 650 to 800 horse power. Finally, in 1852, the annual grant became £186,000. In a recent investigation, Mr. Cunard declared that the value of the capital engaged in the undertaking amounted to £1,000,000. The service is carried on with the greatest regularity, and the company, under the stimulus of American competition, is constantly advancing its improvements. The steamers which it builds are constructed of an increased tonnage, and provided with more powerful engines.

In 1840, the Admiralty signed a contract with the Royal West India Mail Steam-packet Company, for the conveyance of letters to the West Indies and the Brazils. The annual payment was fixed at £240,000 for the maintenance of 14 steamers, of 400 horse power, and of 4 sailing vessels, of 100 tons. These vessels visit the most important ports of the West Indies, and the coast of America. The contract was renewed in 1852 for eleven years, in consideration of an annual grant of £270,000.

The line between Chagres and Valparaiso is conducted by a third company, the Pacific Ocean Steam Navigation Company, established in 1840. It expended two-thirds of its capital in six years, although its ships were exempt from all imposts in the ports of the American Republic, and had obtained from the commencement the monopoly of the carriage of letters. A first contract with the Admiralty, signed in 1846, granted to it an

annual payment of £20,000, which was ultimately doubled, for a bi-monthly service, effected by means of four vessels, of 400 horse power.

The first undertaking of the Peninsular and Oriental Company was the establishment, in 1837, of a monthly service between England and the principal ports of Portugal, Cadiz, and Gibraltar, for which it received an annual payment of £29,600. In 1839 it undertook to convey the English despatches direct to Alexandria, touching at Gibraltar and Malta. Four years later, in consideration of a payment of £160,000 a year, it established the lines to India and China. By the last contract, dated 26th Feb., 1852, it received from the Treasury the sum of £199,600 for the service of the numerous lines to the coast of Portugal and Spain, the Mediterranean, the Black Sea, the Indian Ocean, Indian Archipelago, and Australia. The enumeration of these lines and their different branches would occupy too much space; we can only point out the extent and importance of the lines under the management of the Peninsular Company, and state the fact, that it possesses actually 27 vessels afloat, 11 upon the stocks, 4 steamers serving for stores, and that the property thus employed amounts to the enormous sum of two millions.

Three other companies have the management of the regular lines from Southampton to the west coast of Africa, to Sydney and to Calcutta, by the Cape of Good Hope. Their vessels visit all the English colonies of the Atlantic Ocean and the Indian Sea.

Such is a summary of the lines of steam communication assisted by the Treasury. The total amount paid to these companies reaches nearly £800,000.

The lines as yet established by the Government of the United States are much less numerous. Only three regular lines exist at present between the United States and Europe:—1st, The Collins line, from New York to Liverpool, which, after many disasters, was forced to solicit an increased contribution from Congress, and now receives 33,000 dollars per voyage. 2dly, That from New York to Bremen, touching at Southampton, which receives from the Government 16,666 dollars per voyage. 3dly, That from New York to Havre, touching at Cowes, which only receives 12,500 dollars per voyage. The contractors for the two latter lines have declared the sums placed at their disposal to be quite insufficient. By an act passed on the 31st August, 1852, Congress authorized the Government to conclude a new contract, which stipulated for an increased payment, an increase in the number of voyages, and the substitution of the port of Antwerp for that of Havre, as the point of destination for the third line. In addition to these transatlantic communications, the United States possess a regular line of steamers from Charleston to the Savannah, from New York to Chagres, from Panama to San Francisco; and the Government proposes shortly to establish new lines from Boston to Halifax, and from New Orleans to Vera-Cruz, touching at Tampico.

Although the Americans are far behind the English in the creation of lines of steam-packets, they have made immense progress during the last five years. In 1848, the sum advanced by the state for the transatlantic lines hardly exceeded 100,000 dollars; in 1852 it reached 1,896,250 dollars. Congress is always ready to come forward for the encouragement of private enterprise; it is impelled to this, not only by a regard to commercial interests, but by a spirit of rivalry with Great Britain; and public opinion becomes very strong in the United States whenever there is a question of multiplying postal intercourse, of encouraging commerce, strengthening its commercial navy, or, above all, of contending with the English.

It is clear, from the experience of England and the United States, that such lines of steam navigation cannot be maintained without having recourse to the state. The first attempts to carry on this branch of industry independently, met with nothing but failure. And even with the sums granted under existing contracts, considerable as they seem at a first glance, do the companies derive any profit? Are they what is commonly called successful? As far as the American companies are concerned, there is no doubt but that their yearly amount shows a deficit, since the Government and Congress have recently been obliged to increase the grant to the line of Collins, and since the companies, having the management of the lines to Havre and Bremen, urgently solicit further assistance. As to the English companies, the question is much easier of solution. If we were to judge from the dividend of 8 per cent. paid annually by the Peninsular Company to its shareholders, and not including the sums expended in insurance, which form a separate account, we might suppose that the capital employed in steam navigation was amply remunerative; but the lines to the United States and the West Indies are far from producing such brilliant results. It was shown, on an official inquiry, that from 1842 to 1848 the dividends had scarcely exceeded on an average 3 per cent.

Certainly no one will dispute the necessity of making the state bear

a part of the expense of steam communication. In point of fact, the sum really granted is not so great as at first appears, since the Governments of England and the United States have reserved to themselves the amount paid in postage on the whole correspondence carried on by means of the steam-packets. The sum thus paid is considerable. Mr. Cunard stated in 1851, before a committee of inquiry, appointed by the House of Commons, that from the line between Liverpool and New York alone, the Treasury received, on account of postage, the sum of £140,000. The director-general of the post-office of the United States declared, in the report of 1852, that the postage of letters carried by the vessels of the company, Cunard and Collins, had yielded to the Treasury, in 1851-52, the sum of 463,615 dollars. Thus, in some cases, the postal revenue covers a great part of the grant.

The advantages to the nation are likewise very apparent, when we consider the impetus given to commerce, and the consequent increase in the receipts of the different branches of indirect taxation, especially at the custom-house. During the year 1851, the merchandise imported from Europe to America, by the lines of Liverpool, Havre, and Bremen, paid to the custom-house of New York £1,560,000 in entrance dues. A great part of this merchandise, consisting mostly of articles of luxury, would doubtless not have been imported, if the orders could not have been executed more promptly than by the sailing vessels. To justify the increase solicited in the amount of their grant, the contractors for the line from Bremen to New York have pointed out, that, since the establishment of the line, the importations from Germany to the United States have increased from three million dollars to ten millions—that is to say, have tripled. In England the results have been the same, as may be seen from a statement of Mr. Anderson, a member of Parliament and director of the Peninsular Company, before a commission of inquiry as to the steam navy. 'Some years ago,' says Mr. Anderson, 'a supplementary grant was solicited of the Chancellor of the Exchequer, to establish a communication between London and Constantinople, which should reduce the length of the voyage from 24 to 13 hours. After some hesitation the increase was granted, and in a few years the exportations from England to Turkey increased by more than £1,200,000. In 1848, the steamers of this line exported from Southampton merchandise to the value of £1,000,000; and the Greek merchants, who are chiefly engaged in this traffic, declare that this increase is to be attributed to the creation of lines of steam-boats, which allow of an increased employment of capital, and assure the arrival of the merchandise, destined for different markets, by a stated time.' By exact calculations, Mr. Anderson showed that the above increase of exportations to Turkey, procured for the Exchequer, by means of indirect taxation, an increased receipt of £120,000. The other lines established by England have exercised an equal influence on commerce and on the revenue; they have immensely encouraged the production of manufactured articles, which, without them, would not have found such advantageous markets abroad.

The large amount of the grants is justified by the fact, that the transatlantic companies have not restricted themselves to the execution of the onerous clauses of their contracts, as to the distribution and frequency of the transits which they engaged to effect. They have not hesitated spontaneously to enlarge their operations, to extend their line, increase the number of their voyages, and, in a word, to give the public more than they were bound to do. For example, Cunard's Company, which had only contracted for a bi-monthly transit during the winter, has organized weekly voyages throughout the year. In the same way, the Peninsular Company has established several lines which were not expressly stipulated for; and the increased expense has been voluntarily supported by the contractors, without further contribution from the Treasury.

THE MECHANIC'S LIBRARY.

- Agricultural Chemistry, 8vo., 6s. 6d., cloth. Liebig.
 Coal Mines, their Danger, &c., 8vo., 3s. 6d., cloth. J. Mather.
 Daguerreotype, American Hand-Book of the, 4s. 6d., cloth. Humphrey.
 Elementary Mechanics, Part II, "Dynamics," 5s., cloth. H. Goodwin.
 Encyclopaedia Britannica, 8th edition, Vol. III., 4to, 24s., cloth.
 Inorganic Chemistry, Hand-Book of, third edition, 5s. 6d. Gregory.
 Magnetism and Electricity, Researches in, 8vo., 6s. 6d. Reichenbach.
 Microscope, Curiosities of the, square, 6s. 6d. Rev. J. H. Wythes.
 Microscope, On the, Highley's Scientific Library, Illustrated 5s., sewed. Schacht.
 Microscopist, second edition, post 8vo., 6s., cloth. Rev. J. H. Wythes.
 Microscopical Science, Quarterly Journal of, Vol. I., 8vo., 17s., cloth.
 Mineralogy, Manual of, post 8vo., 6s., cloth. J. Nichol.
 Natural Philosophy, Hand-Book of, third course, 16s. 6d. Dr. Lardner.
 Organic Analysis, Hand-Book of, 12mo., 5s., cloth. J. Liebig.
 Patent Mode of Reefing Topsails, royal 8vo., 3s. 6d., cloth. Cunningham.
 Plane Co-ordinate Geometry, post 8vo., 3s. 6d., cloth. Rev. W. Scott.

RECENT PATENTS.

CLEARING APPARATUS FOR YARN.

W. STEVENSON, *Manager for Messrs. Houston & Co., Johnstone.*
Patent dated March 14, 1853.

This simple contrivance relates to an arrangement of an adjustable apparatus, to be fitted to spinning, twisting, reeling, and winding, and other machinery employed in textile manufactures, for clearing the threads or yarn from knots, loose fibres, or foreign adbering substances. It consists, under one modification, of a duplex plate, suitably slotted or notched, to receive the yarn, and permit the free passage through of the latter, whilst the edges of the slits detain the objectionable matters. The two plates are laid one upon the other, and when the slits in each plate coincide, the yarn has a full wide opening to pass through—that is to say, the apparatus will clear a coarse thread. But when a finer thread is under treatment, or when the thread is to be nipped tighter, or to be more stringently acted upon, by this cleansing process, the attendant traverses one plate longitudinally upon the other, so as to bring the series of slits out of a direct or parallel line with each other. This movement obviously diminishes the width of the slit, and by this means a single apparatus is made to answer for any variety of yarn, as the openings may be set to any width less than that of the actual slits in each plate. The invention is obviously applicable to various kinds of work, and is suitable for effecting the clearance of all kinds of yarn. This general plan of clearer may be modified in various ways. For example, the apparatus may consist of two or more holding bars, on which are attached slips of metal, the clearing surface being thus composed of two adjustable slips; and the attendant has simply to traverse the bars, to widen or narrow the whole of the interstices at once.

Fig. 1 of the engravings is a side or end elevation, in isolated detail, of the actual operating parts of a winding frame, as employed for winding yarn from the cop or pirn, on to bobbins, in the ordinary process of textile manufacture; but modified and fitted up according to Mr. Stevenson's plans. Fig. 2 is an enlarged side view of one modification of adjustable clearer detached, with a corresponding edge view of the same beneath; and fig. 3 is a back reversed or interior view of the same arrangement of clearer.

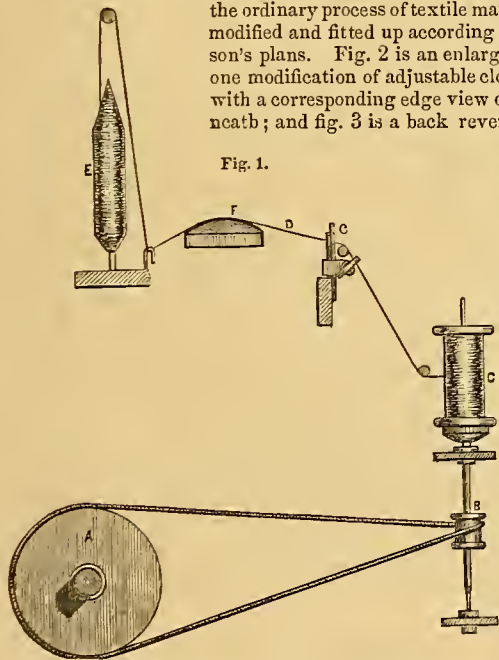

Fig. 1.

central portion of the frame. It is in its passage between these two holders—the cop and the bobbin—that the cleansing action occurs. As the yarn leaves the cop, it passes through or over suitable guides, and thence over the top of the wooden bar, F, covered with some coarse material, to give a "drag" to the passing threads; thence the yarn passes immediately through the clearer plate, G, and round other suitable guides, to the bobbin. In this particular plan of clearer, that apparatus is composed of the two separate parts, H I, laid together in a parallel line, and adjustable by the thumb-screw spindle, J. The main wide front plate, H, is slotted out on its upper edge, pretty widely at intervals, as at K, to suit the intervals of the lines of yarn being wound, the two parallel edges of each of these slots being slightly inclined, or expanded, in the direction of the yarn's passage. This front plate is attached, by stiff friction, to the other parallel plate, I, by means of adjustable screws, L, in the plate, H, and passed through short slots in the opposite plate. This opposite or inner plate, I, has in it slots or notches, M, considerably wider

than those in the plate, H, and these wider notches fit over, or embrace the square pieces or projections, N, which are either cast on, or attached to, the inner side of the plate, H, these square pieces, N, being arranged to lie in the same plane as the plate, I, whilst one edge of each piece coincides with the centre line of each slot in the plate, H. A small bracket holder, O, is attached to one end of the plate, I, to form a fixed bearing or abutment for the collar journal of the thumb-screw spindle, J, the screwed portion of which is passed through a tapped eye, or nut-piece, P, fast on the corresponding end of the plate, H. The result of

Fig. 2.

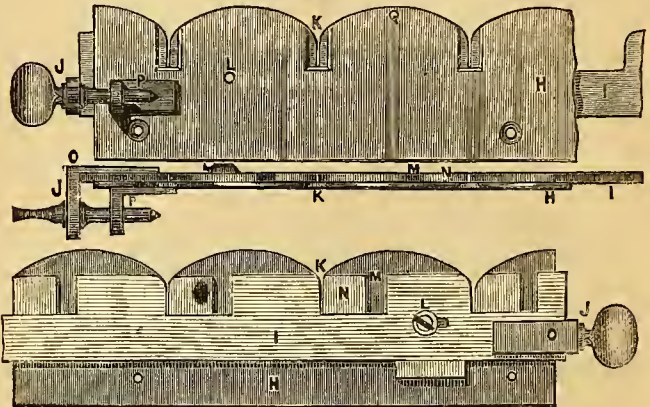

Fig. 3.

this arrangement is, that the attendant, by turning the screw, J, in either direction, traverses the plates upon one another, to widen or narrow the cleansing slits, as may be required. For although the openings in the plate, H, remain constant to the same width—which must be greater than is ever required for the cleansing operation—yet the traversing movement brings the acting edge of each piece, N, nearer to, or further from, the opposite parallel edge of the wider slot in the piece, I; and thus the cleansing slots are all adjusted in the same plane, as if they were simply made in a single flat plate.

Mr. Stevenson also shows his apparatus applied to a reel; and he further illustrates his contrivance under another form, consisting of two flat plates, each being slotted through on one edge, with a series of narrow cuts. The two plates are attached, alongside each other, by screws and slots; and the necessary adjustment for varying the clearing pitch is accomplished by a thumb-screw spindle, fitted, as already explained, in reference to the other figures. When the plates are so set, with regard to each other, that their slots all coincide, the clearing edges are then obviously at their widest distance asunder, and the coarsest thread for which the clearer has been constructed will pass freely through. On the contrary, the more the slots are made to clear each other, or come out of their even parallel line, by so much will their thoroughfare be narrowed, to suit a comparatively fine thread. In each of these two examples, the clearing slots are formed at the points of springing of the arched curves, Q, on one or both of the plates, as may occur, under the special modification used. The object of this is, that when an end breaks, or, from any other cause, a thread has to be passed laterally into its clearing slot, it will first press upon this rounded or inclined surface, Q, and then slide off into its allotted slot. Instead of being arched or curved, these parts may, of course, be angular or shaped, with a duplex incline, so as to cause the threads to glide freely into their slots.

SULPHURIC ACID, ALKALIES, AND THEIR SALTS.

G. ROBE, *Glasgow.*—*Patent dated March 26, 1853.*

In making sulphuric acid according to this invention, the vapour of sulphurous acid is passed over peroxide of iron, mingled with heated air, and the result of this process is sulphuric acid.

Then, to produce sulphate of soda, the vapour of sulphurous acid is passed, along with heated air and steam, over a mixture of common salt and peroxide of iron. Another branch of the invention relates to the production of sulphuret of sodium, for the manufacture of carbonate of soda. This is accomplished by mixing the materials for the production of the sulphuret of sodium with sulphuret of calcium, or soda waste, so that the sulphuret of sodium becomes workable on the large scale, by being rendered innocuous in its effects upon the apparatus employed in the process.

In employing peroxide of iron for the production of sulphuric acid, the patentee uses, by preference, the pyrites cinder, resulting from the combustion of iron pyrites, as commonly produced in the manufacture of sulphuric acid at present. The pyrites cinder is first reduced to small pieces, or to a state of powder, and in this condition it is placed in a furnace or kiln. Round this kiln are ranged a set of pyrites burners, such as are commonly used by sulphuric acid makers; and these burners are so arranged, that all the products of combustion effected in them may pass into the kiln containing the pyrites powder. Common pyrites is deposited in these burners, and roasted in the ordinary manner, highly-heated atmospheric air being at the same time admitted at the bottom of the pyrites kiln. By this arrangement, the vapour of sulphurous acid, and the oxygen of the atmosphere, being simultaneously brought into contact with the pyrites in the kiln, which pyrites is kept at a dull red heat, the resultant combination forms sulphuric acid.

In making sulphate of soda, by passing the vapour of sulphurous acid over peroxide of iron and common salt, mixed together, and kept at a dull red heat, the patentee prefers to use the spent cinder from pyrites burners. Such spent pyrites cinder is reduced to a powder, and the common salt is mingled with such powder, and this compound is then placed in such a kiln or chamber as has been already described; the sulphurous acid is then passed through the heated materials, producing sulphate of soda. In manufacturing carbonate of soda, the patentee first produces a sulphuret of sodium, and then decomposes such material by the action of carbonic acid. The common sulphate of soda is in this process decomposed by the action of suitable carbonaceous materials, in a kiln or common furnace. The ordinary materials for the production of sulphuret of sodium are mixed with sulphuret of calcium, or soda waste, so that the operator is enabled, by this admixture, to make the sulphuret of sodium on the large commercial scale, as that substance is, by this treatment, rendered innocuous in its effects upon the apparatus employed in the manufacture, both as regards the furnaces or operating chambers, and the necessary iron tools of the workmen.

SULPHURIC ACID, ALKALIES, AND THEIR SALTS.

GEORGE ROBB, *Glasgow*.—*Patent dated April 2, 1853.*

This invention relates to the manufacture of sulphuric acid, sulphate of soda, sulphate of potash, and sulphurets of sodium and potassium, and their carbonates, so as to secure superior economy in the several processes. In making sulphuric acid, the vapour of sulphurous acid is passed over or in contact with the peroxide of iron, manganese, or other metals, with or without the addition of clay or alumina, mingled with heated air, and this produces sulphuric acid. But, in order to obtain the essentially necessary superior heat, carbonic oxide in a state of combustion, or the products of combustion of any clear, bright, burning body, are passed through the materials, so as to insure a superior result. To produce sulphates of soda and potash, the sulphurous acid is passed along with heated air and steam over a mixture of common salt or chloride of potassium and peroxide of iron, manganese, or other oxide, with or without clay or alumina, as hereinbefore mentioned; the direct heat of any clear burning body, as hereinbefore mentioned, being also used in this part of the process. In making the sulphurets of sodium and potassium for the production of the carbonates of soda and potash, the sulphates of soda and potash are mixed with the sulphates of lime, baryta, strontia, magnesia, or other sulphates, or the sulphurets of these bodies, or soda waste, either individually or mixed. The carbonic acid gas may be obtained from the carbonate of soda or potash, which has been made with carbonic acid gas by a process of combustion.

In employing oxide of iron for the production of sulphuric acid, Mr. Robb uses, by preference, the pyrites cinder resulting from the combustion of iron pyrites, as commonly produced in the manufacture of sulphuric acid at present. When oxide of manganese is used, any of the ordinary manganese ores of commerce may be thus employed: the pyrites cinder, or oxide of manganese, is first reduced to a coarse powder, and it is then commingled with about one-fifth to one-tenth of its weight of common clay or argillaceous earth; or, instead of this added matter, alumina may be used; the compound so made is then made up into a paste with water, when it may be moulded into balls, bricks, or suitable manageable masses. As the special nature of the incorporated materials necessarily varies occasionally, the proportions stated are also equally variable; and in some instances it is preferred to mix a quantity of ground coke or anthracite, or small coal, in the mass, so that, as this carbonaceous addition burns out in the subsequent calcination of the balls, the masses will be left in a more highly porous condition, and better suited for the purpose intended. Such bricks or masses are then dried

in a common stove, until they are hard and difficult of fracture. In this state they are placed in a furnace resembling an ordinary limekiln, or, what is technically known in Scotland, as a "drawkiln." Round this kiln are ranged a set of pyrites burners, such as are in ordinary use by sulphuric acid makers. These burners are so arranged, that all the products of the combustion effected in them may pass into the composition kiln. Common pyrites is deposited in these burners, and roasted in the usual manner, highly heated atmospheric air being at the same time admitted at the bottom of the composition kiln. By this arrangement, the sulphurous acid vapour and the oxygen of the atmosphere being simultaneously brought into contact with the composition masses or bricks at a dull red heat, the resultant combination forms sulphuric acid. During this process, carbonic oxide, or other cheap combustible gas, may be advantageously introduced at different parts of the composition kiln, so that the kiln may be still better heated throughout; the admission of surcharged or superheated steam is also advantageous. And instead of using pyrites in this way, as the source of sulphurous acid, the patentee uses as well sulphur, sulphuretted hydrogen, or artificial sulphuret of iron; or the sulphurous acid employed may be obtained from any known source. In making sulphate of soda by passing sulphurous acid over oxide of iron, or manganese and common salt mixed together, and retained at a dull red heat, the preferable oxide of iron is, as already described, the spent cinder from pyrites burners—or manganese, which may be used over and over again, may be similarly employed; the salt and oxide are made up into balls or bricks with clay or alumina, and such masses are introduced into a kiln, such as already described, passing the sulphurous acid through them. Any artificial mode of heating may be used, but, in the case of pyrites, this is unnecessary. The whole of the common salt is readily decomposed in this way. If steam or moisture is admitted into the kiln along with atmospheric supply, muriatic acid is given off. But if the air and the materials are thoroughly dry, chlorine gas is evolved by the process.

In manufacturing carbonate of soda, a sulphuret of sodium is first produced, and this is then decomposed by the action of carbonic acid. The ordinary sulphate of soda is, in this process, decomposed by the action of suitable carbonaceous materials in a kiln or common furnace; but there is added to the sulphate of soda a portion of sulphate of barytes, or strontia, or lime, or magnesia, or other sulphate or sulphuret; or a mixture of these said materials; or ordinary vat waste from the alkali makers, mixed with one or other of these compounds. By the agency of such additions, the operator obtains a sulphuret of sodium, which does not corrode the furnace or the iron tools nearly so rapidly, as when the sulphate of sodium is decomposed by itself with carbonaceous materials; and it is with this object that these mixtures are used. The result of this process is, that an easily lixiviable mass is obtained; and the residuum may be continuously used over and over to assist in the decomposition of fresh sulphate of sodium. Such sulphuret may be decomposed by the action of bicarbonate of soda, according to the process patented by Mr. J. Wilson in the year 1840. But Mr. Robb especially uses the bicarbonate of soda as a source of carbonic acid, for effecting the decomposition of sulphuret of sodium, placing the bicarbonate of soda in a separate vessel or chamber, and generating the carbonic acid by the agency of heat. The bicarbonate may be produced by causing the common carbonate of soda to absorb the products of the combustion of carbonaceous materials. In practising this process, the sulphuretted hydrogen evolved may either be turned into sulphurous acid, for the production of sulphuric acid; or its sulphur may be recovered by heating it to redness, or by passing it into a chamber where it meets with sulphurous acid.

SHIPS' MASTS AND SPARS.

R. M'GAVIN, *Glasgow*.—*Patent dated March 31, 1853.*

Mr. M'Gavin's important invention relates to the so combining wrought-iron and timber in the construction of the masts and spars of ships, that great strength may be secured, with economy in first cost, and a reduction in weight and bulk. In building a mast or spar on this principle, the core or main centre is made of wrought-iron, of cruciform transverse section, by taking one long plate of iron of a breadth equal to the requirements of the intended spar, and attaching two other plates at right angles thereto, one on each side, along the centre. These two additional plates are each of half the breadth of the main single plate, the attachment or combination being effected by rolling or shaping an angle on one edge of each of the two narrow plates, so that the whole can be riveted together. The four spaces thus left between the four projecting edges or wings of the skeleton mast or spar, are then filled in with pieces of wood, glued up together with marine glue, or other adhesive substance;

and the whole being hooped round with malleable iron hoops or riugs, a light and strong structure is produced at a moderate cost.

Fig. 1 of the engravings is an external elevation of the lower or "step" end of a ship's mast of this kind; and fig. 2 is a horizontal section of the mast.

Fig. 1

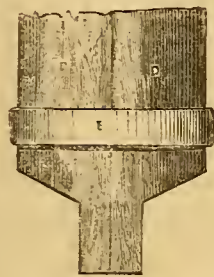

Fig. 2.

In constructing a mast in this way, a long main central plate, *A*, is first rolled and prepared to suit the required dimensions of the mast, the width of the metal being considerably less than the diameter of the finished mast. *B B* are the two additional side pieces necessary to make up the intended cruciform section of this wrought-iron core. Each of these pieces, *B*, has an angle, *C*, rolled along one edge, so that, when the two pieces are disposed on opposite sides of, and at right angles to, the main plate, *A*, rivets can be passed through the angle pieces, *B*, and through the main plate, along the centre line of the latter, to combine the three pieces into one frame piece or core. The four spaces or divisions, *D*, are now filled up with wood, and the whole is bound together by the iron hoop, *E*, so as to form a mast of completely solid cross section. The wood so filled in, is not relied upon as a direct means of supporting strength, its essential office being the filling up of the divisional spaces to form a solid mass, and prevent the buckling of the plates of the core.

For, as the presence of a solid body between each two divisional pieces, or wings, *A*, *B*, prevents either of such wings from swerving out of its normal plane, it follows that each plate, *A*, *B*, is disposed in the best possible manner to meet lateral strains. That is to say, all lateral strain is directed through each plate, in a line parallel with the plane of such plate, where there is the greatest resisting depth of metal. Hence, the filling-in wood may be in short small pieces—as, provided the wood is sound, such short pieces, when well joined by marine glue or otherwise, so as to leave no objectionable openings along their contact surfaces, are quite as efficient as longer ones.

Various means may be adopted for effecting the junction of the constituent pieces of the wrought-iron core. For example, a double angle, or *T* edge, may be rolled or formed on the edge of each of the side pieces, instead of the single angle; or the pieces may be left entirely without flanges, separate angle-irons being riveted to one edge of each separate side piece—such angle pieces being then riveted by their other free flange to the main plate. In making yards, the longitudinal central portions of the iron-plates are made of a superior width, so as the better to resist lateral strain; or, instead of this widening of the metal, its thickness may be increased by a gradual swell towards the centre, either rolled in the plates, or made by the addition of separate tapered pieces to the main backbone pieces. Such a system of constructing masts and spars is suitable for a great variety of works, and especially for the jibs of cranes, where a combined longitudinal and lateral resistance is required. As regard its use in shipbuilding, this invention is one of the most valuable improvements of modern times, as it will most materially reduce the weight, dimensions, and cost of all large masts. Experimental tests have shown, that it is almost impossible to break a properly made mast of this kind; and hence it appears, that the enormously thick masts hitherto used for large vessels, will be replaced by others of far more modest and manageable dimensions.

BLOWING AND EXHAUSTING FANS.

ALEXANDER CHAPLIN, *Glasgow*.—*Patent dated May 10, 1853.*

Mr. Chaplin's practically valuable invention relates to the arrangement of what, under an earlier modification,* we have already named a "Duplex Pressure Fan," whereby a high degree of pressure is attainable with a low rate of working, whilst the details are simple and easily adjustable, and not liable to injury in working. In this arrangement, two fan-cases are combined in each fan or blower, a single actuating spindle being passed directly through the axial lines of the two cases, which are thus coincident, space being left between the two cases to receive the central driving-pulley on the spindle. The fan-boxes or cases are each cast with one side on, the other side being a loose plate, and attached separately. Each case has its own fan, both fans being

fast on the same single spindle, and each having three arms forged, or cast, in a single piece with the boss, the sheet-iron vane-blades being riveted on to the arms; but other numbers of arms may be used. The fan-bosses are fastened on to the shaft by square shoulders, with a tightening nut, and the spindle is carried in bearings in cross bars, fast to the inner contiguous faces of the two cases. The air is taken by one of the fan-cases through the usual central apertures or induction passages, when the fan is used for exhausting, and it is delivered by a tangential passage at the periphery, in a direction at a right angle to the fan's axial line. This air is then conveyed diagonally across, by a communicating passage under the sole-plate, to a central side-opening in the inner face of the second case; and the fan, in this case, then finally expels

Fig. 1.

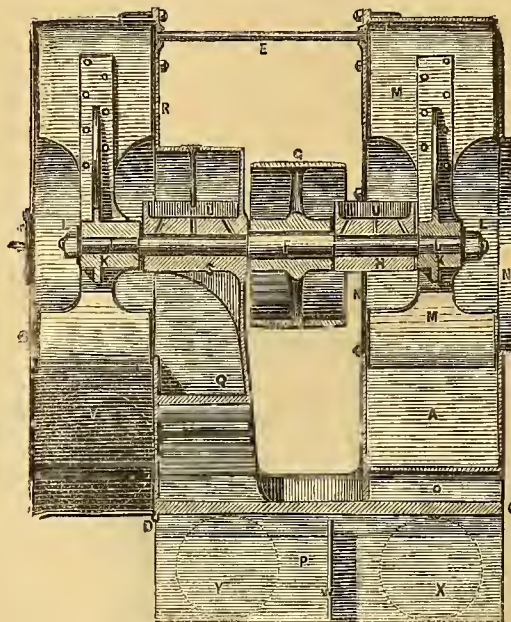

the air through its tangential opening. In this way the duplex action affords a superior degree of pressure, whilst the fan runs steadily, from its being driven by a central pulley. The moving parts and bearings may be easily removed without disturbing the sole-plate, or inner cheeks, or side-plates; and, except where a high pressure is desired, half the ordinary amount of speeds and gearing may be dispensed with. By a simple arrangement and modification of valves and passages, this improved blower is capable of effecting the double process of blowing and exhausting at the same time; or, on the other hand, as an exhaustor, it may be contrived to exhaust with the whole of its power, as derived from its duplex action.

Fig. 1 of our engravings is a plan of the fan, and fig. 2 a transverse vertical section. *A* is the primary or supplying fan, which takes in the air to be transmitted; and *B* is the increased pressure or transmitting fan. Both fans are of the same diameter, but the supplying one is rather wider than the discharger; and the two cases are bolted down on the same level, *C D*, with a single sole-plate, a stiffening connection being provided at the upper end in a cross rod, *E*. A single spindle, *F*, actuates the combined apparatus, a hand or strap pulley, *G*, being fast on an enlarged central portion of this spindle, so as to enable the actuating power to be communicated at the centre of the apparatus, and thus insure steadiness of working. The spindle, *F*, is carried near one end, in a long bearing, *H*, in a cross bracket, *I*, bolted to the inside of the fan-plate, or cheek. Outside this bearing is a square shoulder, or seat, *J*, on which the boss, *K*, of the vanes, or fan-arms, is fitted, the setting-up adjustment being effected by the frictional hending nut, *L*, on the spindle end. The vanes, or fan-blades, *M*, are riveted to the solid arms of the boss, *K*. When at work, as a duplex action blower, the air to be transmitted enters on each side of the case of the fan, *A*, by the two opposite central apertures, *N*; and as it is compressed by the vane action, the air so taken in then descends through the bottom thoroughfare, *O*, and enters a bottom cross passage, *P*, beneath the fan sole-plate. The passage, *P*, may be prolonged downwards, to afford a better passage for the air across. This pas-

sage, *p*, conducts the air current into the ascending thoroughfare, *q*, which has an opening at its upper part, in direct communication with the central induction-opening in the pressure discharging fan-case, *n*. This secondary fan-case is constructed in a manner very similar to the first one, except that its inner plate, or cheek, *r*, has cast upon it the passage, *q*, in which again is cast the long spindle bearing, *s*. It has, besides, no open communication with the external atmosphere, the only aperture in the case, on one side, being that which is in connection with the passage, *q*; whilst, on the other or outer side, there is merely a door or slide, *t*, for oiling and examination. The spindle bearings are kept in a well-lubricated condition by oil receivers, *u*, filled with loose cotton or other soft material, suitable for giving out the oil slowly to the bearing surfaces. The vanes and fan spindle are the same at this side of the apparatus, as the corresponding parts already referred to. The air, conducted into the secondary case, *b*, in the manner which has been explained by the passage, *q*, now receives a secondary pressure from the action of the revolving vanes on this side; and in this condition it is now expelled from the case, *b*, through the bottom tangential passage, *v*. In this manner a high pressure is obtainable with a slow rate of revolution of the fan spindle, as the

Fig. 2.

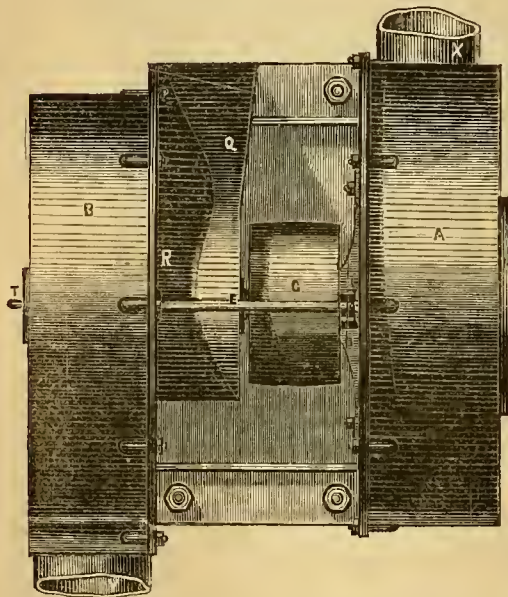

second fan, *b*, takes up the air at whatever pressure may be developed in the first fan, *a*; and hence this initial pressure in the second fan is increased, in proportion to the effect exercised upon it in the second fan, so as to give a much superior final pressure. The adoption of the separate loose cheeks in the fan-cases, with the arrangement of the cross bracket, *i*, affords peculiar facilities for erection and removal, or examination. For when the cross bracket, *i*, is taken out, the whole of the working parts may be at once separated, as required, without disturbing the fixed or stationary portions of the apparatus.

Instead of using this fan for merely obtaining a high blowing or forcing pressure, the primary fan, *a*, may alone be used as a single-action blower. To effect this, the stop-valve, *w*, governing the bottom passage, *r*, between the two fans, is closed; and the air still being taken in by the two opposite central ports, *x*, it is expelled under a single-action pressure through the pipe, *x*, which is only attached to the apparatus when it is to be employed in this manner. Then, when the process of exhausting is to be carried on simultaneously with this blowing action, by the instrumentality of the second fan, *b*, the valve, *w*, being still kept closed, the additional pipe, *x*, is to be connected to the cross passage, *p*, or to any part of the induction passage of the secondary fan. When so arranged, air may be drawn or exhausted from any desired quarter through this pipe, *x*, and discharged from the case, *b*, at *v*; or, if the exhausted matter is offensive, the discharged current may be conveyed out of the way through an extension pipe. If, again, it is intended to provide for a duplex-action exhaust, with the full power of both fans, the intermediate valve, *w*, in the connecting passage between the two cases, is opened, and the central opening in the inside cheek of the case, *a*, is closed. At the same time, the exhaust pipe, *x*, must be put in communication with the central opening in the outer cheek of the fan-cases. In this way, the entire undivided power of the apparatus will be employed in exhausting, the exhausted air being taken in at the outside central aperture in the case, *a*, and conveyed away through the tangential discharge thoroughfares of both fans.

WARP DELIVERY FOR POWER-LOOMS.

C. PARKER, Dundee.—Patent dated March 7, 1853.

Mr. Parker's contrivance relates to the construction of power-looms in such manner that the delivery of the warp from its carrying beam or roller, may be effected in a continuously uniform and regular manner, during the whole weaving operation, quite irrespective of the varying diameter of the warp-beam, consequent upon the gradual withdrawal therefrom of the warp as the weaving proceeds. To obtain this effect, the warp-beam is arranged to rest, through the actual mass of wound-up or beamed warp, upon a roller, which is driven at a continuously uniform speed of revolution, through the intervention of gearing in connection with the main crank or tappet shaft. This roller, so driven, communicates its motion to the warp-beam by frictional contact; and as the periphery of this driving roller always passes through equal spaces in equal increments of time, it necessary follows that it will communicate a uniform surface velocity to the warp-beam, whether the latter is full or nearly empty; the warp-beam having liberty to sink down upon, and approach to its actuating roller, as the warp is unwound. The result of this arrangement is, that when the working speed of the driving roller is once adjusted, it will cause the warp to be delivered from the beam to the weaving details at a regular rate, until the beam is quite emptied, thus doing away with the usual dragging of the warp-beam, and mitigating the severity of the strain upon the warp threads.

Our engraving represents a vertical transverse section of the warp-beam and its driving roller, as thus fitted in a loom. The warp-beam, *a*, has the two ends of its spindle entered into vertically-slotted pieces, on the inner side of each end standard of the framing, so that the mass of beamed warp rests fairly upon the roller, *b*, beneath, the beam having full liberty to traverse a short distance vertically by the working of its spindle through its slotted guides. The roller, *b*, is driven at a uniform rate by gearing from the tappet shaft, and as its frictional contact with the beamed warp causes the beam, *a*, to revolve, the line of warp threads, *c*, passes off inside the roller, *b*, wrapping nearly round it on the lower side. Thence the threads pass up outside the roller, and clearing the warp-beam, to the horse, or whip bar, *d*, whence they pass directly to the point of weaving.

A loose pulley is fitted on each end of the warp-beam spindle, and over each of these pulleys is hung a cord, *e*, one end of which is secured to a stud in the framing, whilst the opposite free end is linked to an adjustable weighted lever. The object of this contrivance is the production of a satisfactory downward pressure for keeping the beamed warp well in contact with its roller, and prevent all chance of slipping; there being no "drag" whatever upon the warp, inasmuch as the warp-beam is forcibly carried round by the frictional roller action, against whatever amount of friction may arise from the action of the weighted pulleys. When the warp has to be taken back at any time, the weaver accomplishes the movement by working a foot lever in connection with the disengaging movement of a pair of bevil-wheels in the line of gear between the tappet shaft and the roller, *b*. As long as the weaver's foot presses this lever, the bevil-wheels remain out of gear; but when the pressure is removed, a coiled spring, connected with the lever, forces the wheels into gear again. By this plan, the weaver can allow any number of weft threads to go into the cloth before delivering any warp; and this, in many cases, will supersede taking back altogether.

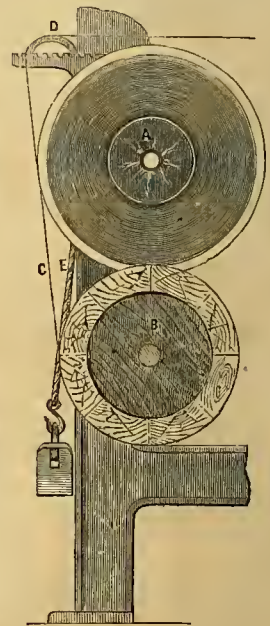

DRESSING AND SIZEING MACHINES.

W. BASHALL, JUN., Preston.—Patent dated March 14, 1853.

Mr. Bashall's useful contrivance relates to the application of lubricating matter to cotton and other yarn, or warp threads, after such threads have passed through the sow or dressing trough of dressing, sizeing, or tape machines, in the ordinary process of dressing, sizeing, or preparing the warps for being woven; the object of such treatment being the ren-

dering the yarn or warp threads more open, softer, and less wiry than warps treated in the ordinary manner; and the removal of the usual harshness in such threads, as well as the commonly experienced tendency of the individual threads to become matted, or adhere together. The substance applied to the threads in carrying out this system of preparation is oil, or any conveniently obtainable oleaginous or greasy matter. Such lubricating or softening substance is applied to the threads by means of a roller, partially immersed in the lubricating matter, and arranged so that it shall revolve in contact with the threads, and transmit the determined quantity of the lubricating matter to the threads in a continuously uniform manner. The matter employed is applied to the threads, after the latter have passed through the usual dressing or sizing trough, or through the finishing rollers, or after passing over the drying cylinders. This system of treatment is applicable in the preparation of warps by any of the machines now commonly in use. For the finer yarns, the common dressing machine may be used; but Mr. Bashall has adapted the process in his own works, to what is known by manufacturers as "Hornby and Kenworthy's patent sizing or dressing machine."

In using these improvements in the latter machine, a transverse trough or receiver is fitted up across the framing of the machine, close to the drying cylinders, such trough having in it the oil or other lubricating matter which is to be employed. Immediately over and dipping into

this lubricating trough is a transverse roller, carried in suitable end bearings in the framing, and actuated by gearing from any convenient movement of the machine, so as to rotate at the speed determined by the operator. Then, as the warp emerges from the dressing troughs, it passes over or round the heated drying cylinders in the usual manner; and after leaving such drying surfaces, the threads pass over the top or upper side of the revolving oil-distributing roller, and are thus suitably saturated with the oily matter. The warp then passes off from the machine, and is otherwise treated in the usual way. The oil trough is kept supplied with its contained fluid by a separate reservoir, conveniently disposed in an open space in the machine framing, a pipe from which reservoir has an adjustable valve in it, so that the flow can be set by hand to the amount required during working. And in order that the oleaginous supply may be accurately suited to the wants of the warp at all times, the stopping mechanism, whereby the dressing or sizing operation is started and suspended, has suitable connections attached to it in such manner, that when the machine is stopped, the line of warp threads is elevated from contact with the lubricating roller or surface; and when the machine is again put in motion, the starting mechanism similarly brings down the line of warp threads to bear against the lubricating roller. The same movement is also connected with the oil-supply pipe from the reservoir, so that, when the machine stops, all waste of oil is prevented.

SAFETY APPARATUS FOR RAILWAYS.

ROBERT WALKER, Glasgow.—Patent dated March 24, 1853.

Fig. 1.

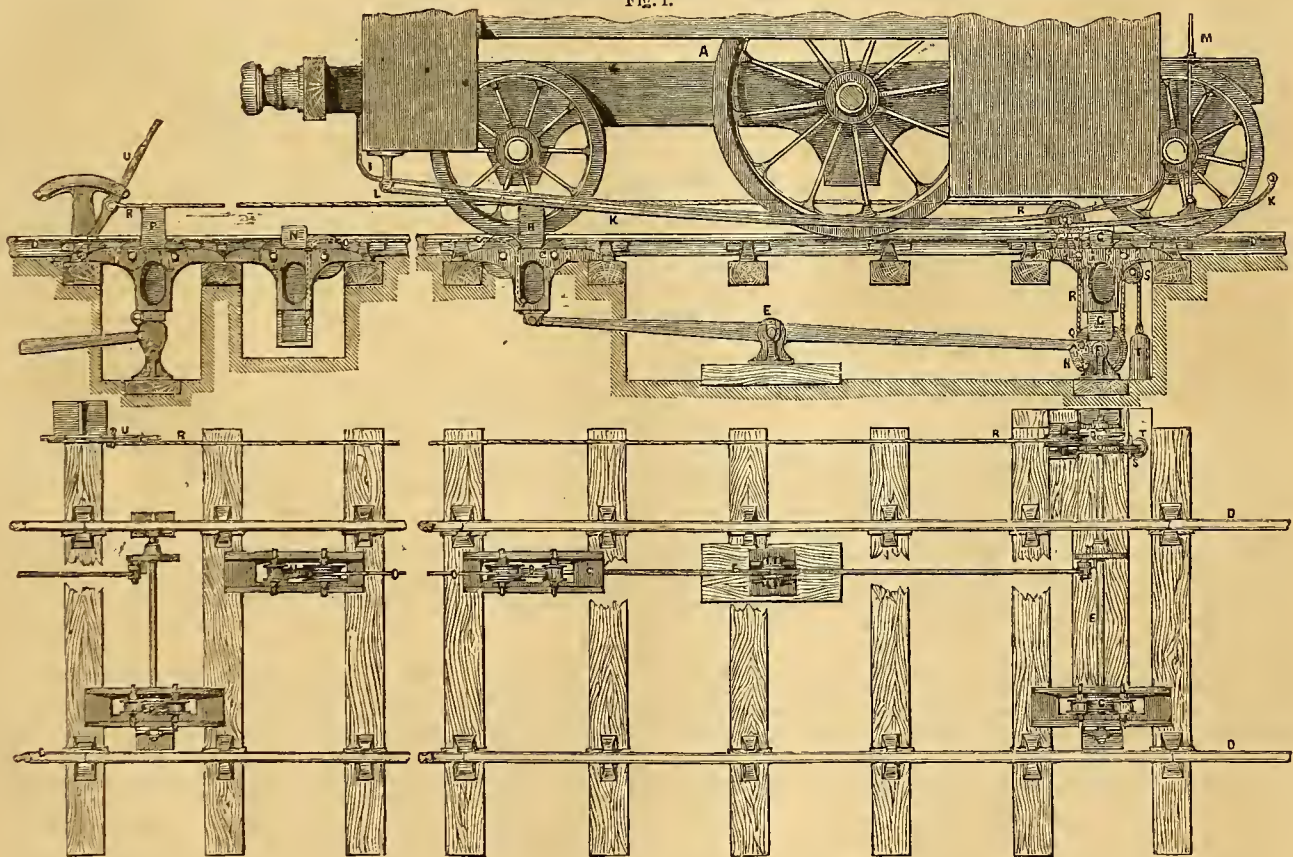

Fig. 2.

Mr. Walker's contrivance, which we briefly noticed last month, is now fully illustrated in the annexed engravings—fig. 1 being a side elevation, and fig. 2 a plan of a portion of a railway, fitted up with the apparatus, and having a locomotive in action upon it. The arrangement, which is in this instance self-acting, is placed at suitable intervals of a quarter or half a mile for example, along the line, and the engine, A, is represented as in the act of passing over it. At n is an upright catch-piece, working vertically between friction pulleys, in a cast-iron cas-

ing, c, lying between and below the surface of the rails, D. The catch-piece, n, is connected by the double-armed lever, e, and a short link, to a disc or crank on the short transverse spindle, f. This spindle passes beneath a second catch-piece, g, similar to the catch-piece, n, but in the rear of the latter. A small cam, u, is fast on the spindle, and is so adjusted that, when the catch-piece, n, is depressed, it shall, by means of the connections described, be caused to turn round, and lift up the catch-piece, g. The cam, u, is of such a shape that, when elevated, no downward pressure can

cause it to turn; and it therefore keeps the catch-piece, *g*, up, until acted upon by the lever, *e*. The first catch-piece, *b*, is placed near the left-hand rail, for example, whilst the other one, *g*, is placed near the other, or right-hand rail. For the purpose of depressing the catch-piece *b*, a rod, *r*, is fitted to the under side of the engine. This rod has a gently curved shape, so as to come upon and depress the catch-piece in a gradual manner. A second rod, *κ*, is fitted to the engine, in a position to come in contact with the catch-piece, *g*. This rod is connected by a joint, *l*, to the fore end of the engine, whilst at the other end it is jointed to the vertical rod, *m*, which communicates with the regulator valve, whistle, or brake gear, or with all these at the same time. The rods, *l* and *κ*, are each curved at both ends, so as to act equally well in whichever direction the engine is proceeding. It will thus be seen that the engine, *a*, in passing over the apparatus, will, by means of the fixed bar, *r*, depress the catch-piece, *b*, and, as a consequence, raise the catch-piece, *g*, in the rear; so that, if a second engine be following, the rod upon it, corresponding to *κ*, will come in contact with the catch-piece, *g*, and, by means of the rod, *m*, the steam will be cut off, so as to bring the engine to a stand. The catch-piece, *g*, will remain elevated until the engine, *a*, reaches the next safety apparatus; but in order that it may not remain elevated longer than this, a third catch-piece, *n*, is placed immediately behind the next apparatus. This catch-piece, *n*, is connected by a cord or wire, *o*, with the first catch-piece, *n*, in such a manner, that when the latter, *n*, is depressed, the former, *n*, will be elevated, and *vice versa*. Thus the engine, passing over *n*, will have depressed it, and elevated *n*; but on reaching the latter, this will, in its turn, be depressed, and the other one, *n*, consequently elevated. The elevation of the catch-piece, *n*, however, causes the depression of the catch-piece, *g*, as already shown; so that, on the arrival of the engine at *n*, the catch-piece, *g*, will cease to be elevated, and a succeeding engine will be able to pass it unimpeded. At *p* is a catch-piece of the second apparatus, and corresponding to *g*. It is shown elevated, this indicating that the engine in advance of the one, *a*, has not yet reached the third apparatus; so that on reaching *p*, the engine, *a*, would be stopped. When necessary, the mechanism may be actuated by hand, by pulling the cord, *o*, in either direction. When this means of stopping trains is employed near stations, and at other places, where great care is required, the spindle, *r*, of the cam, *u*, which serves to elevate the catch-piece, *g*, has fixed upon it a pulley, *q*, round which passes the cord or wire rope, *r*. This cord passes on one side over a small guide pulley, *s*, and is attached to a counterweight, *t*, which stretches it, and binds it tightly upon the pulley, *q*, and also brings the pulley back to its normal position, when the other end of the cord is released. This other end of the cord is attached to a hand lever, *v*, under the control of the signalman, and is precisely similar to the apparatus at present in use for actuating signals at a distance. When the signalman wishes to stop an advancing train, he draws the lever, *v*, towards him. This action turns the spindle, *r*, by means of the cord, and with it the cam, *u*, consequently elevating the catch-piece, *g*. This catch-piece acts on the stop-rod on the engine in the manner already described, and causes the stoppage of the train. Where this last-described arrangement, for use near stations, is employed, the remainder of the self-acting mechanism may be dispensed with; and the cords and other gear, already fitted up for actuating signals, can, at very slight expense, be adapted to work the safety apparatus in conjunction with the signals, and, in this case, as well as in all cases where the stopping apparatus is not fitted continuously along the line, each train may be provided with a catch-piece, which the guard can deposit at a short distance in the rear of the train, in case of accident or stoppage. Or, according to another of the plans specified by Mr. Walker, a series of disconnected adjustable catch-pieces may be fitted at intervals along the line, so that, in case of accident, the guard can go to the nearest one and raise it, so as to stop a following train.

REGISTERED DESIGNS.

LIBRARY DESK, OR DEVONPORT.

Registered for MESSRS. J. W. & T. ALLEN, West Strand, London.

As an article of furniture, this very elegant and convenient desk is similar to an ordinary Devonport; but, as a desk proper, it is a very great improvement upon all previous contrivances of its class. Fig. 1 is a perspective view of the desk complete, with its top opened for use. Fig. 2 is a detached view of the top as closed down. At the back is a closing rack, containing articles of stationery, arranged in compartments; and immediately in front of this is a tray, containing two inkstands, tapers, and lights, with all the usual cells for the minor adjuncts of the desk. The actual writing top, in front, is capable of sliding forward far enough

to allow the hinged stationery rack to turn down when necessary. This done, and the top pushed back, the whole may be secured by a lock on the front drawer. The ink range is attached to the back rack, and is

Fig. 1

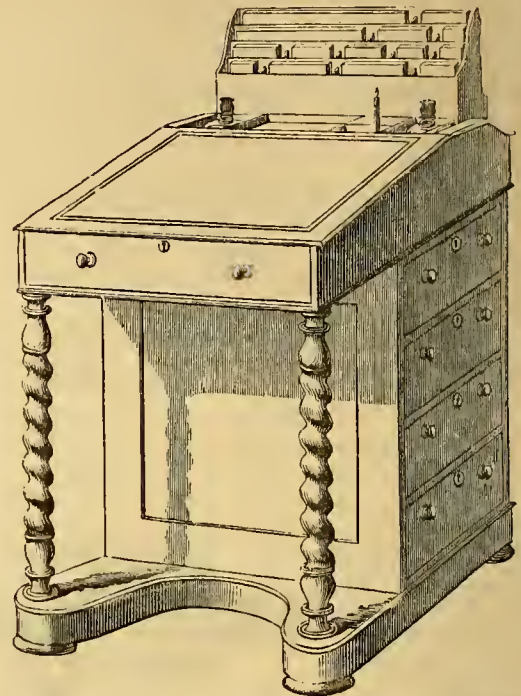

suspended on pivots, so that it constantly maintains a horizontal position. Down the sides are drawers for papers. In this arrangement, everything is most conveniently presented to the writer; and when the

Fig. 2

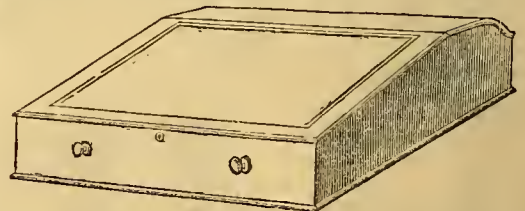

articles are not in use, they can be closed at once within the desk at one operation, assuming their former position when required, without derangement. The desk is 22 inches square, and 32 inches high.

INK-BOTTLE.

Registered for MESSRS. BLACKWOOD & Co., Long Acre, London.

Our engraving represents this bottle as made in glass, to be used instead of the common stoneware bottles. The makers' object has been the carrying out the principle of their larger clean-conducting spotted bottles, down to inkholders of the smallest size. Like the spotted bottle, this little contrivance effects a clean satisfactory pouring discharge into any inkstand; and it may itself be used as an inkstand, the aperture presenting an inclination suited to the position of the pen when taking a dip.

The bottle, from which we have made our drawing, contains a new bluish-black writing fluid, lately invented by Mr. Pinkney, of Messrs. Blackwood's firm. This fluid, unlike common ink, is not a precipitate kept up in suspension by gummy matter, but is a true chemical solution, which flows freely from the pen, and improves by atmospheric exposure in the inkstand. It brings with it a great deal of comfort to the writer.

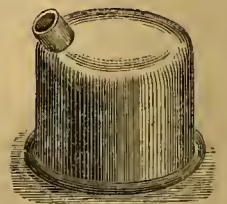

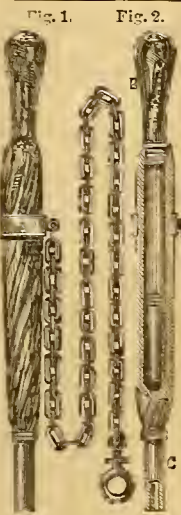

ORNAMENTAL WATCH-CHAIN CONNECTOR.

Registered for MESSRS. WHITMORE AND WINSTONE, Manufacturing Jewellers, Union Court, Old Broad Street, London.

This pretty little toy is an improvement upon the ordinary transverse key attached to the end of watch-chains, for connection with the button-hole of the waistcoat. Our engravings represent it full size. Fig. 1 is an external view of the connector complete; fig. 2 is a longitudinal section to correspond. Externally, it is a miniature umbrella, the closing ring, A, for the cover of which, is fitted with a small link for the chain attachment. The handle, B, ornamented by an inserted stone or jewel, has a screwed shoulder for insertion in the body piece, and the inner projecting part is contrived to answer as a pencil-case, or toothpick. The opposite end, C, is the winding-up key for the watch.

REVIEWS OF NEW BOOKS.

REPORT TO THE HEALTH COMMITTEE OF THE BOROUGH OF LIVERPOOL, ON THE SEWERAGE, PAVING, CLEANSING, AND OTHER WORKS, UNDER THE SANATORY ACT. By James Newlands, C.E. Pp. 60. Liverpool. 1853.

The report in April, 1851, of Mr. Newlands, the able and indefatigable borough engineer of Liverpool, afforded us a more than ordinarily good opportunity of discussing the question of sanitary measures in large towns.* The pages now before us are no less suggestive; we find from them that, in the two years comprehended between April 1851, and April 1853, nearly 14 miles of sewers have been constructed in Liverpool, making nearly 31 miles, as the aggregate of construction since the passing of the sanitary act. And to bring the matter still more boldly out, the author gives us an elaborate table, showing the total cost, cost per lineal yard, and the average cost per lineal yard, of these works. An analysis of this statement stands thus:—

Sewer, 3 feet 6 inches, by 2 feet 3 inches, cost	£1 1 3 per yard.
" 3 feet, by 1 foot 10 inches,	0 14 11 "
12 inch pipe, cost 8s. 4d.; and 9 inch pipe, 6s. 1½d. per yard.	

These works have been carried into some of the most unhealthy districts of the town, where the beneficial results may be expected to be particularly strongly marked; and it is worthy of attention, that in most cases the owners of property have shown their appreciation of the benefit conferred on them, by availing themselves of the construction of the sewers, and draining their houses, without even requiring the usual notice. This is a healthy state of affairs, of which, we are afraid, few other towns can boast.

As regards the cleansing of sewers, Mr. Newlands commends the process recently patented by Mr. Blades, the surveyor for the north district, as described by us in August last. The experimental tests of the plan are thus stated:—

" Each yard of sewer, on an average, contained of loads of silt, .29; and required in day's labour of a man to cleanse it, .113, and in actual time, .032 days—while, by the old plan, each yard of sewer containing the same amount of silt, required of a man's time, 3 days; and occupied in cleansing, .1 day. Or to make the matter more plain by an example:— Suppose a sewer is 100 yards in length, silted up to the depth of 1 ft. 6 in. Then, by the old process, the cleansing of it would occupy 3 men, 10 days; and by the new process it would occupy 11 men ¼ of a day.

" The power which the new apparatus gives of employing many men together, and of rapidly finishing the work, is a most material advantage, and this, with its obvious economy when compared with the former mode of cleansing, will, I think, insure its general adoption."

The Liverpool experience in paving has led to the general substitution of square sets for builders, and "macadam," the system most expensive in first cost, being found there, as elsewhere, to be the cheapest and most satisfactory in the end. What Mr. Newlands says on this subject, may be consulted with advantage by all who are interested in the question of how our street-ways ought to be constructed. The pamphlet, which bears prominent marks of care in its arrangement, is furnished with a good index, a feature too often overlooked in books of far higher pretensions.

* Page 229, Part XLVI., *Practical Mechanic's Journal*.

CORRESPONDENCE.

CLOUGH'S SAFETY APPARATUS FOR MINES.

The accompanying sketches represent my proposed plans for arresting the chance fall of buckets in mine shafts, from the breaking of the suspending ropes. I am told by parties in this quarter, that it is useless to attempt the introduction of any such precautionary measures, for the reason that mine proprietors would run their ropes too long, and hence increase the risk of failure. But it seems to me, that on the same principle we might remove all the drag-chains from our carriages and waggons, for fear the poles and harness should be kept in work too long.

Fig. 1 is a vertical section of a shaft—say of 7 feet diameter—with a bucket, A, suspended in it. If the rope, B, should break, spiral or other springs, C, in the side of the bucket, would force out the iron levers of the third order, N, and cause the rectangular points, at their upper ends, to enter the joints of the bricks or stones of the shaft wall, so as to arrest the bucket's fall. The levers are guided in their movements by horizontal slotted projections, set diametrically opposite to each other on the bucket.

Fig. 2 is another contrivance for the same object. Here, if the suspending rope, A, should fail, the india-rubber springs, B, would come into operation, and, by their reactionary spring, cause the two crossed beams or spars, C, to close or collapse. In other words, these spars would turn upon their central joint pin, N, and the points, E, on the lower ends of the spars would then enter the wall. The dotted lines indicate this movement, and show how the bucket would remain suspended from the upper end of the spars, the ropes or chains passing freely through rings or slots. I am satisfied that no safety contrivance can work properly without a spring somewhere. Mr. Norecombe of Heavitree states that his safety bar will turn by its own gravity. It might do so, perhaps, before the bucket reached the bottom of the shaft; but the jerk at that time would be so excessively violent, as to throw every man out of the bucket.

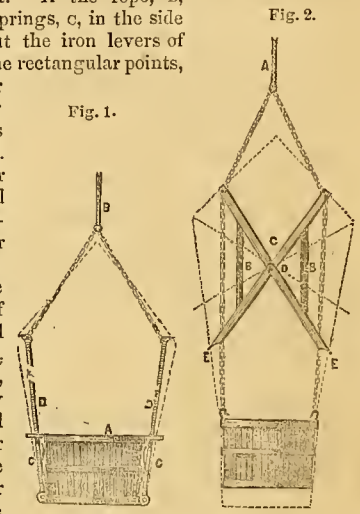

Tyddyn, Mold, November, 1853.

C. BUTLER CLOUGH.

TEMPLATE FOR IRON SHIPBUILDERS.

As shipbuilders are now quite sensible of the benefits derivable from templating the plates in iron vessels, I beg to submit to you a plan of template, which I shall have much pleasure in seeing in the *Practical Mechanic's Journal*. Fig. 1 is a side view of the apparatus complete.

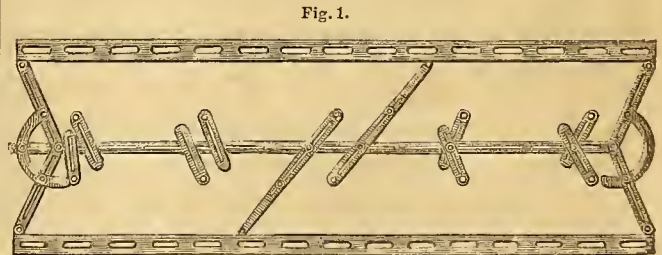

It is designed with a special view to lightness, and with as few parts as possible, to be adjusted in applying it to the side of a vessel. The parts between the holes in the two main frames are cut out, thus necessitating the use of a double pin for marking off the plates. The frame is fitted to an adjustable apparatus, the ends somewhat resembling the common workshop compasses, with quadrant and screw for receiving the frame when set. There is a longitudinal bar for varying the piece for inserting the holes in frames. It is jointed at one end, but left loose at the

other; but when the frame is set, it is fixed by a bolt, like all the other connections. The middle pins are double, jointed at one end to the frame, and screwed together with two bolts in each.

Fig. 2.



Fig. 3.

It is obvious that this contrivance will answer only for one pitch of rivet-holes. To make a universal template, I propose to slot out the frame pieces for their entire length, the holes being represented by a short hollow tube, with a hole corresponding to the size of the rivet wanted. This is shown in figs. 2 and 3, where the short tubes have each an end collar on one side, and a nut screwed on the other, with two slots to unscrew by. The sides of the frame might be set out into various pitches, so that the workman would simply require to unscrew the bolts to fix them at the desired pitch.

JOHN G. WINTON.

Glasgow, November, 1853.

SOFTENING CAST-STEEL FOR TOOLS.

Would you be good enough to state, in the *Practical Mechanic's Journal*, how cast-steel may be softened, so as to be workable into tools of various kinds? Several different plans have been tried, but none have yet succeeded satisfactorily.

E. S. D.

November, 1853.

NORCOMBE'S SAFETY APPARATUS FOR MINES.

The annexed sketch represents my simple apparatus, which I have recently introduced, for the prevention of mine accidents, from the failure of ropes or chains. It consists of a safety-bar, A, either of wood or of tubular iron, about 9 inches in diameter, and 17 feet in length, for a shaft 12 feet by 9 feet. The diagonal measurement of such a shaft will be 15 feet 6 inches, and the additional 1 foot 6 inches will prevent the bar from turning in the shaft. To the upper end of this safety bar, a heavy iron band or collar, n, is attached, a link being added for connecting this part to the main bucket rope or chain, c, by the small chain, d. At the centre of the bar is an iron eye, e, capable of turning easily in any direction; and through this eye, the main supporting chain, c, is passed. A small iron bar, f, is fastened at right angles to the main chain; and on this cross-piece the eye, e, rests, keeping the safety-bar in its place. At g is the safety-chain, securely fastened to the bucket at h, the upper end being fastened to the bar, A, at i, at a distance of three feet from the centre. The lower end of the bar, A, is armed with a sharp iron or steel point, k.

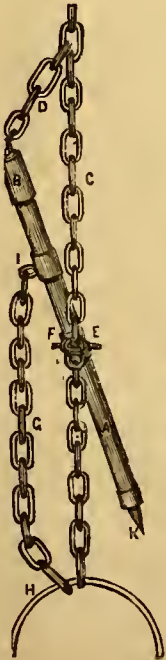

When in action, the heavy upper end of the bar has a tendency to fall, but is prevented from coming down by the small chain, d. But should the main chain or rope break, the suspended weight at once comes upon the safety-chain, e; and as the connection of this chain with the bar is at a point, three feet from the centre of the latter, this arrangement, aided by the weighted end, b, gives the bar a tendency towards a horizontal position. Hence the spike, k, catches in the side of the shaft, and the bar, A, becomes wedged tight in it, and supports the bucket.

E. S. NORCOMBE.

Heavitree, October, 1853.

THE REV. J. BRODIE'S IMPROVEMENTS IN SAILING VESSELS.

The first part of these improvements, which I have lately patented, consists in employing two or more vessels, joined together at the side, but placed at such a distance from each other as will secure their stability as floating bodies, and allow the water they displace to pass freely between them. One or more of these vessels

must be of such a size and form as to contain the crew by which they are navigated, with such portion of the cargo to be carried as may be desirable, while one or more may be of smaller dimensions, and be principally designed to serve the purpose of giving stability to the others. The vessels are connected together by means of spars or beams of wood, or rods or bars of iron.

The second part of the invention consists in building vessels of such a form as to avoid the ordinary curvature of the sides and bottom, and to substitute, in lieu thereof, a formation of the sides and bottom, relatively disposed in such a manner as to form an angle, the one with the other—that is to say, the bottom being flat, or nearly flat, and the sides rising from it in a straight line, or nearly so. Also, these vessels have their stem and stern so formed as to be sharp in their horizontal section.

The third part of the invention consists in the adapting and applying to vessels, whether of the form above described or not, a moveable stem or cutwater, fitted to the fore part or bows of the vessel, in such a manner as to admit of its being raised out of its place, and lowered down again, when circumstances require.

Stability.—Twin vessels will evidently possess a far greater degree of stability than any single vessel would have. They are placed at such a distance from each other, as may permit the water displaced by the bows to pass freely between them. It is to the neglect of this important consideration, that we are to attribute the failure of the attempts that have hitherto been made to make double vessels really useful. A smaller boat, or a log of wood, may be suspended on spars stretched out to leeward, like the outriggers of native boats or prahus of India. These outriggers, however, are only useful when the vessel is under sail. They will impede the rowing of the boats, and afford but little security when the sea is rough. The author's first idea was to employ one or two outriggers, to give stability, while the rowers sat in a boat between them; but a very little consideration enabled him to see that a mere outrigger would not effectually serve the purpose.

Advantages of a similar kind will result from the employing vessels with flat bottoms and perpendicular sides. When we examine the build of ordinary boats, we find that their shape, when viewed endways, resembles the letter V. Their sides, therefore, form an acute angle with the water. The sides of ships are more nearly perpendicular; but whenever they have the wind a-beam, and lie over before it, a similar remark may be made in regard to the angle which is formed between their bottom and the surface of the water. A wave coming against them in such circumstances acts as a wedge, and its force tends to raise the windward side of the vessel, and turn it over. When the bottom is flat, and the sides perpendicular, the wave has no tendency to overturn the vessel; its force is expended in dashing against the side, and making it move a little to leeward.

Buooyancy.—This object is more especially desirable in life-boats. It is in general attained by having air-tight chambers, or pieces of cork, in the sides. In boats of the construction now contemplated, it is proposed to have the narrow parts, near the stern and bow, divided into air-tight compartments, and the whole bottom filled with layers of cork; so that, with an ordinary complement of men, the top of the cork inside may be level with the surface of the water without. The advantage of this arrangement arises from its offering no obstruction to the progress of the vessel, which cork must do in any other position.

Speed.—To give speed in rowing boats, length of side, to allow room for the oars, is the first requisite; and a sharp bow, and such a form of vessel as shall offer little resistance to the wind and waves, is the next. Ordinary life-boats are made so broad, in order to give them stability, and have so much space occupied with cork and air-tight compartments above, that they offer a very great resistance to a head wind and opposing hallow. The plan now proposed unites together two narrow boats, with sharp bows, so that there is ample length of side for rowing, and little resistance a-head.

In sailing vessels, the larger the sail that can be carried with safety, the greater the speed. Vessels constructed on the plan proposed can carry a spread of canvas much greater than any other vessel of equal burden could bear.

Strength.—Strength is requisite for many objects; two of them may be more especially referred to.

When a vessel rests on a sand-bank or rock, so that the middle is supported while the ends are unsupported, or *vice versa*, when the ends are supported and the middle part is left hollow below, there is a strain which tends to break the vessel in two; and, for resisting this strain, it is of the highest importance that the sides should be made as strong as possible. This strain is exactly similar to that which an ordinary beam, employed in carpenter work, has to bear, or to that which tubular bridges have to sustain. Experience has abundantly shown that beams, and more especially tubes, with a flat bottom and perpendicular sides, are far stronger than circular or rounded ones. Vessels of the common construction are round, and consequently weak; made in the form now proposed, they are square, and consequently strong. Ordinary vessels, moreover, must be made in great part of cross wood; of the form now suggested, the timbers are straight, and the planking is bent only in one direction.

The other object for which strength is more especially required, is for resisting the shock that is produced by a vessel striking any obstacle in its way. When vessels of the ordinary form come against a rock, or similar obstruction, the whole strain of their impetus must be borne by the part of the bottom which is struck; and that part, being possessed of no greater strength than the rest, gives way at once, and a leak is formed. When a vessel with a flat bottom strikes any obstacle, it will be the angle or corner, formed by the bottom and sides, that has to bear the shock, and in that corner the strength of the vessel may be said to be concentrated.

Stowage and Draught of Water.—These are, in many cases, objects of importance, and it is very evident that a square box is more convenient for packing goods

than a round one, and that a flat-bottomed vessel will draw less water, in proportion to its burden, than one of the ordinary form.

Preservation of Life.—Of a largish size, fastened with iron rods, as diagonal stays above, and covered with a strong netting between the boats, a vessel, such as has been described, would form a life-boat, in the ordinary sense of the term, possessing many advantages. It will have great stability, buoyancy, and ample room for rowers, while it will be easily moved through the water, in consequence of the smallness of the resistance which it offers to the wind and waves. The passengers taken from a wreck, if too numerous to be received into the boats, may remain lashed to the netting; and though they will of course be wetted by the waves, the time during which they will be thus exposed must be brief, as no long space can elapse ere a sharp-built boat, running before the wind, reaches the shore. If thought advisable, a sail can be employed without hazard. Life-boats of the ordinary construction are so unwieldy, that it is almost impossible to row them against wind and tide, and, when under sail, are the most dangerous craft that could well be contrived, as experience has painfully shown.

Of a smaller size, and fitted with sails, it will form a safe and commodious boat, either for piloting or fishing. If provided with a deck between the middle transverse beams, the steadiness of its motion, the rapidity of its sailing, and its great stability in the water, will make it very eligible as a pleasure boat. When we take into consideration the number of lives that are annually lost, in consequence of the upsetting of boats, there seems reason to hope that the advantage which would result from this employment of the invention would be very great.

When made so that the boats can be easily taken asunder, and put together again, which can be done by a very simple arrangement, the invention will form a very convenient and effective life-boat for ships to carry with them. The boats, when separate, in moderate weather and ordinary circumstances, could stand close to the bulwarks, and would take up little room. On the appearance of danger, they could be drawn nearer each other, and bolted together in a few minutes, and then launched overboard, without fear of swamping; and being capable of bearing a sail, those who escaped from the wreck would not be left to toss about, perhaps for days or weeks together, at the mercy of the waves.

Fig. 1 represents a method of giving stability and buoyancy to ordinary ships' boats, by means of a frame of wood, formed by two stout planks, which are

Fig. 1.

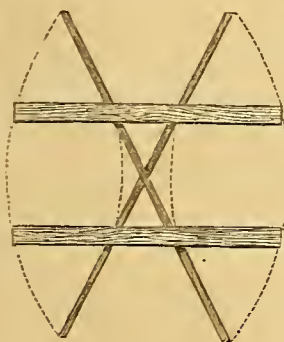

fastened together by means of two spars of a more slender form, which cross them diagonally. The dotted lines represent two boats united together, by being lashed, or otherwise secured to the frame. A quantity of cork on the top of the frame completes the arrangement, which will thus possess both buoyancy and stability. If the boat be made flat in the bottom, and placed on the deck of the vessel immediately behind the steersman, with the frame fastened down to the vessel by means of ties or screws, the other boat (an ordinary ship's boat) might be hauled up to the other end of the beams, and again let down, in the same way that boats are usually hung at the stern of vessels. In case of shipwreck, by loosening the fastenings, the boats and frame would fall together into the sea, and, with ordinary precaution, might be made available for

rescuing the passengers and crew.

Figs. 2, 3, and 4, are intended to illustrate a still more simple contrivance. Fig. 2 represents two seats, like those with which the decks of steamers are usually supplied. Instead, however, of the seats here represented being merely

Fig. 2.

Fig. 3.

Fig. 4.

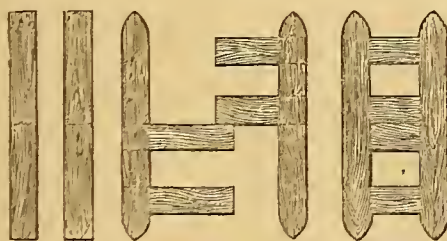

benches for sitting on, they are boxes filled with cork, 16 inches deep, by as many broad, and 10 or 12 feet in length. On the top of these boxes are seats, formed of $1\frac{1}{2}$ or 2 inch plank, divided into lengths of 5 or 6 feet, according to the length of the box which they cover. These seat-boards are fastened to the top of the box by means of pivot hinges, which allow them to slide round upon it. They are also provided with screws, which fit into sockets fastened to the top and sides of the box. When danger threatens, these screws are loosened, the seats turned round, as shown in fig. 3, and then the two boxes are united as in fig. 4. The spaces left open between the boards are covered with netting. The chief recommendation of this contrivance is its simplicity, and the consequent ease with which it may be applied to the object for which it is designed. To place two light boxes opposite to each other, to unfasten a few screws, to turn round the seating planks, to bring the boxes together, to hook on the netting—which, of course, must be kept ready fastened to the back of the boxes—to fasten the screws into their sockets,

and to heave the whole fabric overboard, would be but the work of a minute or two. Whether it fall on the one side or the other, its buoyancy and stability will be the same. Two men could easily cast it into the sea, while in the water it could support the weight of ten; and though some may hesitate to call it a boat, it will form a vessel that could carry a sail with safety, in circumstances in which no ordinary boat could live.

J. BRODIE.

Moniemail, Cupar-Fife, Nov., 1853.

PROCEEDINGS OF SCIENTIFIC SOCIETIES.

THE BRITISH ASSOCIATION AT HULL.

SECTION A.—MATHEMATICAL AND PHYSICAL SCIENCE.

TUESDAY.

“On the Mixture of Homogeneous Colours,” by Professor H. Helmholtz.—The author published, a year ago, experiments on the mixture of homogeneous coloured light, which seemed to prove that there are only two colours in the solar spectrum capable of being combined into white—namely, yellow and indigo. He has repeated these experiments, following another method, similar to that lately described by M. Foucault, for obtaining larger fields equally dyed with the mixture of two homogeneous colours, and has found that there are more pairs of complementary colours in the spectrum. These colours are situated at both ends of the spectrum: on one side, from red up to a yellow shade, a little greenish; on the other side, from violet up to a blue shade, also a little greenish. The shades, however, in the middle of the spectrum, in which the green preponderates, cannot give white with any other homogeneous colour. Their complement is purple, and must be compounded by violet and red. The complementary colour of red is greenish blue—of orange, sky blue—of yellow, indigo—of greenish yellow, violet. The author found, moreover, that the complementary colours are arranged in the spectrum in a most irregular manner. As the breadth of the differently coloured bands in prismatic spectra depends not only on the wave-length, but on the substance of the prism, he refers the following results to interferential spectra, where the distance of two colours is proportional to the difference of their respective wave-lengths. If you pass with an equal velocity through the different colours of such a spectrum, the shade is altered very slowly at both its extremities, in the red and violet, but in those parts where the complements of red and violet are placed, in the greenish yellow and greenish blue, the shade alters very rapidly, so that the distance of extreme red and golden yellow is about ten times greater than the distance of their complementary colours, greenish blue and sky blue. The author observed two circumstances in these experiments, which had prevented him in his former experiments from finding other complementary colours than yellow and indigo. At first, according to the peculiar distribution of complementary shades in the spectrum, the said colours were able to give a larger white spot than the others. Secondly, it appeared to be very difficult to the human eye, which is not quite achromatical, to find and to keep the right focal length for objects illuminated by two kinds of homogeneous rays of very different refrangibility. Indigo and yellow are of less different refrangibility than any other pair of homogeneous complementary colours, and are therefore easily combined. Others, as red and greenish blue, on the contrary, are united in the same field of the retina with great difficulty. Finally, the author gave some remarks on the best method for bringing the whole variety of colours into a system. He stated that Newton's coloured disc appeared to be the most simple and complete manner. Some points, however, are to be changed. First, not only the seven principal colours of Newton must be arranged on the margin of the disc, but the whole definite number of them existing in the spectrum, so that complementary colours are placed in the opposite ends of the same diameter. Secondly, the two ends of the spectrum cannot meet together, but must be separated by an interval, where the complementary colour of the green shades, namely, purple, is to be intercalated. The commonly-received theory of three principal colours, includes a restriction of Newton's method contradictory to the author's former experiments.

“Meteorological Observations made at Hull,” by T. W. Lawton.

“On Parhelia observed at St. Ives,” by J. K. Watts.

“Meteorological Summary, for 1852, of Observations at Huggate, Yorkshire.”—“Continuation, across the Country, of the Thunder and Rain Storm, which commenced in Herefordshire on September the 4th, and terminated on the Yorkshire Wolds on September the 5th, 1852.”—“Notice of a terrific Thunder-Cloud on the Wolds, September the 26th, 1852.” By the Rev. T. Rankine.

“Suggestions on Medical Meteorology,” by J. Day.

“Description of his Graphic Telescope,” by C. Varley.—The author drew attention to the imperfections and difficulties experienced in using the Camera Lucida, and then exhibited and described his instrument. The stand of it united great portability with complete steadiness; and the instrument itself, which had something of the appearance of a telescope, could be adjusted so as to focus the image exactly at the spot where the pencil was to delineate it, and the direct view of the point of the pencil easily caused to trace the picture to be drawn. The object-end also of the instrument could be turned round, so as to place on the paper any portion of the landscape before the author which he wished to delineate; or, if his object were to take the inside of a building, he could take the ceiling, or roof, floor, or any portion of the sides at pleasure.

“On a New Photometer,” by Dr. Price.—The author, by arranging two inclined mirrors in a box, contrived to reflect the standard light and the light to be measured, so as to cross each other at a piece of ground glass or oiled paper on the top of the box; then it was easy, he asserted, to adjust the distance of the standard light, so as to make the two reflected lights appear equally intense; and then,

on the common principle, the illuminating power of the light to be estimated could be calculated.

"On Deep Sea Soundings and Errors therein, from Strata of Currents, with Suggestions for their Investigations," by Dr. Scoresby.—He set out by observing, that the subject of deep sea soundings was one which lately had become of great interest, inasmuch as recent soundings had tended to show that there were profundities in the sea much greater than any elevations on the surface of the earth, for a line had been veered to the extent of seven miles. He believed the first soundings beyond a mile were made by himself, when quite a youth, in the Arctic regions. Since then, in 1819, her Majesty's ship *Pandora* had obtained soundings in the North Atlantic, at 2,060 fathoms. Capt. Basset, in 1848, in the North Atlantic, got soundings at 3,250 fathoms. In 1849, Lieut. Walsh, of the United States Navy, got soundings at 5,700 in the North Atlantic. But a much greater depth had been obtained by Captain Denham in the South Atlantic. In 1852, he got soundings at 7,706 fathoms. After the line had been let out to that depth, it came to a pause. It was then raised a little, and then let out again, when it came to a stop at precisely the same point. The line used was a silk one, one-tenth of an inch in diameter, weighing about one pound to every hundred yards, the plummet weighing about nine pounds, and being about eleven inches long. These were perhaps very favourable circumstances; but there were considerations connected with all deep sea experiments, which rendered these results extremely doubtful, and not only doubtful, but in some cases actually erroneous. This arose from the action of what he had, in a previous paper, spoken of as the strata currents of the ocean—that was, currents flowing beneath each other, in different ways, as he had shown in the case of the Gulf-stream and the Polar current. It would be evident that, in the case of a sounding, where, as with Capt. Denham, a light lead required nine hours, twenty-four minutes, and forty-five seconds to run out, the action of these currents would affect the length of the line run out, and the sounding could not be relied upon. If the sea were a stationary body, or if its currents were uniform movements of the entire mass of waters from the surface to the bottom, then the lead might be fairly expected to take a direct and perpendicular course downwards. But if, in the place of sounding, strata currents, so prevalent in the sea, should be running in different directions, or, what would have the same effect, if one stratum of water, say a superficial stratum, should be in motion, and the main body below at rest, no correct results could be derived. Dr. Scoresby proceeded to show, illustrating his argument with diagrams, that under such circumstances the line would be carried away by the under current, so as to make a bend, which, at great depths, might go to the extent of miles. He had repeatedly noticed this effect when in the Arctic seas, in his youth, hunting the whale, and, by noticing it, had been able to strike many second harpoons, where the other whale fishers had been at fault. He had noticed, that, after a fish was struck, say at the edge of the ice, it had dived in an oblique direction under it, carrying out line for a quarter of an hour or twenty minutes, when there would be a tension of from half-a-ton to a ton on the line, and then pause for a short time. Then the fish would "take line" again, as if under the ice, and perhaps come up a-stern of the fast boat. There could be no doubt that the second pulling out was owing almost entirely to the resistance of the water. But if the boat was in clear water, and run until the pause, then her head would perhaps incline to the right or left. The boats then went ahead of her; but he, instead of doing so, had always gone to perhaps treble the angle of inclination, and had, for the most part, been rewarded by his close proximity to the fish when it rose. Well, then, all circumstances showed that the currents of the sea had very considerable influence on the line when let out; and he came then to the consideration of a plan for the determination of the surface and relative strata currents. No doubt, broad determinations as to great and decided currents and proximate results, by means of multiplied observations on currents of moderate velocities, were derivable from the ordinary process; but for really satisfactory results, far more accurate and conclusive processes need to be instituted. And it would be well deserving, he thought, of an enlightened Government of a maritime country, especially to employ smaller war-vessels and officers in investigations on the subject, for which modes, he believed, might be made available, calculated to yield much useful and interesting information. Two leading processes appeared to him as being applicable to these determinations:—First, the planting in particular positions of inquiry in the ocean, from an attendant vessel, buoys with flags, kept in their places by a resisting apparatus below the surface, which might be denominated a current measurer, and determining, after a night's action, for instance, the changes of their position from celestial observations. Then, secondly, placing a small boat upon the water during a calm, with the current apparatus, for the determination of the relative set of strata currents. The current measurer attached to, and suspended by a small wire, run off a reel fixed in the bow of a boat, might be let down to various depths in succession, with a register thermometer attached at each new depth, when the motion of the boat and its direction, as shown by the position of a surface float or buoy, would, after but short intervals of time, indicate approximately the relative motion of the surface water, and the water at the several depths of the resisting apparatus below.

Dr. Buist said, that Dr. Scoresby had given so much in the way of introduction to what was proposed to have been said, that the accident that prevented the instruments from being exhibited on Saturday, when the paper on currents, which they were meant to illustrate, was read, was almost a fortunate one. Dr. Scoresby had described the only means hitherto resorted to for ascertaining the existence and character of submarine currents; and the same cause that tended to render deep sea soundings uncertain, made the ascertainment of submarine currents by the old methods most unsatisfactory. Dr. Buist then exhibited and explained the new current measurer. As any attempt at a minute description, without a diagram, would be next to unintelligible, it may be stated generally, that the instrument resembled a common weathercock turned upside down, and which, on being lowered by a

wire to any depth, took the direction of the current. It was furnished with a compass, the needle of which was clamped at the proper time by a second wire, when a bladed wheel, like that of a patent log, or of a ventilator, was allowed to revolve for a minute, and worked like a gas-meter, by an endless screw, into a toothed wheel; and when the whole was drawn up, it indicated the direction and velocity of the current at any given depth. He stated that superficial currents were on a large scale, and, from on board ships, best ascertained by what was termed bottle logs, or slips of paper enclosed in a bottle thrown overboard every day at noon, indicating the ship's place, or anything desired to be known regarding her. One of these was exhibited in the form of a common receipt-book, where all the formal part was printed in, and the captain had only to fill it up with writing; counterfoils were left in the book, containing a record of the information thus cast on the waters—these, amongst other things, serving afterwards to indicate what proportion of the log had been picked up, what lost sight of. It was eminently expedient, and occasioned very little trouble, to put a notice on this of the principal adventures the ship might have met with. Had this been always done, the history of the voyage of many vessels that had perished at sea might, up to a certain point, have been ascertained. Dr. Buist also explained other instruments, and then gave an account of a hail-storm in India, in the Peshawur district, by which eighty-four persons, and upwards of three hundred head of cattle, were killed.

Mr. Monday exhibited and described a model of a Self-registering Thermometer.

SECTION E.—GEOGRAPHY AND ETHNOLOGY.

WEDNESDAY.

"On certain Places in the Pacific, in Connexion with the Great Circle Sailing," by the Rev. G. C. Nicolay.

"On a Second Journey to St. Lucia Bay, and the Adjacent Country in South-East Africa," by R. W. Plante.

"On certain Localities, not in Sweden, occupied by Swedish Populations; and on certain Ethnological Questions connected with the Coasts of Livonia, Esthonia, Courland, and Gothland," by G. L. Latham.

SECTION F.—STATISTICS.

TUESDAY.

Mr. Cheshire read a communication from Lady Bentham, widow of the late Bigadier-General Sir Samuel Bentham, on certain statements contained in a communication to the Statistical Section at Belfast, in September, 1852, entitled, "Statistics of Portsea and Portsmouth Dockyard," published in the quarterly Journals of the Statistical Society in June and September of the present year, in which her ladyship corrected a few inaccuracies relating to the dockyard.

"An Analytical View of Railway Accidents in this Country and on the Continent of Europe, in the twelve years from 1840 to 1852," by F. G. P. Neison.

"Statistics relative to Nova Scotia in 1851," by E. Cheshire.
The Rev. F. P. Morris recited some facts bearing on "Practical and Scientific Education."

SECTION G.—MECHANICAL SCIENCE.

FRIDAY.

"The Rise, Progress, and Present Position of Steam Navigation in Hull," by J. Oldham.—In this paper, Mr. Oldham took a retrospective survey of the application of steam power to the propulsion of ships, with a view to prove that Hull has taken a prominent part in the introduction and improvement of the invention. In 1787, experiments were made in Hull, by Messrs. Furnace and Ashton, which resulted in the construction of a steamboat worked with paddles, that attracted the attention of the Prince Regent, by whom the boat was purchased, but it was soon afterwards maliciously burnt. In 1814, the first steamboat on the Humber was established to run from Hull to Gainborough. It was called the *Caledonia*, and it accomplished, under favourable circumstances of the tide, fourteen miles an hour. The first sea-going steamboat sent from Hull was in 1821; and it was supposed to be the first steamboat that plied on the east coast of England. The sea-going steamers that are now connected with the port of Hull, have an aggregate tonnage of 9139, and 2749 horse power. The tonnage of the river-boats is 2218, with 1135 horse power. The other steamboats coming to Hull have a burthen of 5909 tons, and 2236 horse power. There are altogether 80 steamboats trading with Hull, of which number 15 are propelled by the screw.

A discussion arose on the respective merits of the inventors of steam navigation, and the priority of their inventions; in which discussion Mr. Fairbairn, Mr. Bayley, and Mr. Thomson took part. Mr. Fairbairn said, he saw the *Caledonia* enter South Shields, and that it was the first steamboat in the North after Henry Bell's on the Clyde. Bell, it was stated, got the idea of his engine from Symington, and he made propositions to our Government, and to Napoleon during the temporary peace, for applying the principle to war ships; but the plan was rejected, as such a means of propelling ships was considered to be impracticable. In reference to Fulton's claim to be the original inventor of steam propulsion, Mr. Fairbairn said that Fulton had most probably seen an account of Symington's experiments, but there could be no doubt that he had the precedence in bringing out steamboats in 1807, and afterwards more successfully in 1810, when his steamboat was at work on the Hudson.

"A brief Description of Locking & Cook's Rotary Valve Engine, and its Advantages," by G. Locking.—In this engine, a metal disc, with three apertures, slowly rotating on a flat surface, with corresponding openings connected with the boiler and the cylinders, supplies the place of the ordinary slide valves. Rotary motion is given to the valve by a vertical shaft, on which there is a pinion that is worked by a cog-wheel on the shaft of the engine. The two bearing surfaces are

ground steam-tight, and an outer casing serves to confine the steam, as in the common slide valve. The advantages said to be gained by this arrangement are the diminution of friction, and a more ready means of cutting off the steam and reversing the engine. As the rotary valve has a continuous slow motion, the inconvenience and friction occasioned by the rapid reciprocating action of the slide valve is avoided. Among other advantages of this contrivance, it was stated that it cost less, is less liable to get out of order, and occupies less room. Mr. Cook, the inventor, is a working mechanic in Hull.

Mr. Fairbairn, Mr. Roberts, Mr. Hancock, and other gentlemen, expressed themselves favourably of the invention, and, at the conclusion of the business, the members of the Section paid a visit to Messrs. Locking and Cook's works, to inspect a steam-engine constructed on this principle in action.

"On a new Thermostat for Regulating Temperature and Ventilation," by W. Sykes Ward.—This apparatus consists of a series of flat circular hollow cases, about one foot in diameter and one inch deep, attached together in their centres. Each case contains a small quantity of sulphuric ether, which is readily affected by change of temperature. The cases, comprising about six, are suspended one under the other, and to the lowest one is attached a weight by a cord that passes over an eccentric pulley. On an increase of temperature the ether expands, and the weight falls down, and it is drawn up again by the pressure of the atmosphere on the external discs of the cases when the air is cooled. By connecting the weight with the ventilators of a conservatory, or other building, the temperature can be thus regulated to any required degree by a previous adjustment of the apparatus.

"On a Compound Safety Valve," and "On an Improved Tubular Boiler," by James Hopkinson.

MONDAY.

"On the Tubular or Double Life-Boat," by Col. Chesney.—This life-boat, invented by Mr. H. T. Richardson, was one of those that competed for the Northumberland prize; and after the award of the prize to Mr. Beeching, of Yarmouth, Mr. Richardson had a boat constructed on his own model, and challenged the prize-bearing boat and all others to a trial on the sea. The boat is formed of two tubes of tinned iron, 40 feet long by $2\frac{1}{2}$ in diameter, and tapering at the ends. An iron framework unites the two tubes, which are divided into water-tight compartments, occupied by air-tight bags, and the whole is surrounded by a cork fender. Seats for the rowers and passengers are placed above the framework. Col. Chesney stated that this boat had undergone several severe experimental trials at Plymouth with great success; and he expressed his conviction that it cannot be upset.

The discussion on this subject was adjourned to the following day, when Mr. R. Roberts described a life-boat of his invention. It consists of an iron shell, with a hollow keel, made wide enough to admit, the feet of persons sitting in the lower part. The sides of the boat are to be lined with two water-tight compartments, and there is to be a hood at the stern, also containing air vessels, to assist the boat in righting itself in case it should be capsized. It is proposed to propel the boat by spiral vane propellers, to be worked by persons standing on the platform. The advantage which Mr. Roberts claimed for his boat was, that the weight was placed very low, and the buoyant air-vessels above, by which means it would be prevented from capsizing.

A model of another life-boat, which is intended to be placed at Spurn Point by the Trinity House, was exhibited by the Mayor. It is to be constructed of wood, and the buoyant chambers are to be under the seats.

In the discussion that ensued, objections were raised to the double life-boat, on account of the weight being placed so high, and the difficulty of working it; whilst Mr. Roberts' boat was objected to as being complicated in its arrangements, and containing no provision for the escape of water when filled.—Capt. Kater, Capt. Calver, and other nautical men, expressed doubts whether any of the life-boats recommended would sufficiently answer the purposes required of them.

"On some recent Improvements in Machines for Tilling Land," by B. Samuelson. "Experimental Researches to determine the Strength of Locomotive Boilers, and the Causes which lead to their Explosion," by W. Fairbairn.—These experiments were undertaken in consequence of the explosion of a locomotive boiler in the engine-house of the North-Western Railway Company at Manchester, by which several persons were killed, and a great part of the roof of the engine-house was destroyed. The immediate cause of the accident was the carelessness of the engine-driver, who had screwed down the safety-valve to stop its noise whilst he was talking to a companion, and had forgotten to unscrew it. In twenty-five minutes from the time the valve was closed the boiler burst. The Government Inspector who examined the wreck of the engine, was of opinion that the stays had been defective, and that the boiler had not been sufficiently strong for its work. Mr. Fairbairn, on the contrary, thought that all the parts had been strong enough to resist six times the ordinary working pressure, and that the explosion could not have been produced by the accumulated generation of steam till it had arrived at a pressure of at least 300 lbs. on the square inch. In consequence of this difference of opinion, a series of experiments were instituted to determine the real causes of the explosion, and to register those facts for future guidance, in guarding against such catastrophes.

"On an Experimental Apparatus constructed to determine the Efficiency of the Jet Pump, and a Series of Results obtained," by J. Thomson.—Mr. Thomson last year gave, in this Section, an account of a machine which he had contrived, for the purpose of raising water from beneath the lowest available level of discharge, by means of a supply of other water coming from a higher level. This machine he designated a jet pump, because it raised water by the action of a jet; and it had at first been intended chiefly to empty the pits of his vortex water-wheels, or other submerged turbines, when access to them is required for inspection or repairs. During the progress of the trials, however, which were made of it for this purpose,

it soon gave indications of having much more extensive uses, and of being likely to prove, in certain cases, an advantageous machine for draining swampy land or shallow lakes. The cases of this kind for which its employment was contemplated are, those in which the low ground to be drained happens to have, adjacent to its margin, streams or rivers descending from higher ground. With a view to determining its efficiency and its applicability in any particular cases of this kind, Mr. Thomson had recently constructed an experimental apparatus, in which a jet pump could be made to act, subject to great variations in the ratio of the height of lift to the height of fall, and which was suited for indicating accurately the quantity of water lifted, and the height of the lift, corresponding to each quantity of water allowed to fall through any given distance within the working range of the apparatus.

"On Improvements in Machinery for Grinding Corn," by W. Crosskill.

TUESDAY.

"On the Combined Steam and Ether Engine," by G. Rennie.—Mr. Rennie, after noticing the many attempts that have been made to employ spirituous vapour as a motive power, described a successful invention by M. Dutromblet, for the combination of ether vapour and steam, which is now applied in propelling a ship from Marseilles to Algiers. There are two cylinders, of different diameters, into one of which ether vapour is admitted, and into the other steam, the two motive agents being kept entirely distinct. The steam-engine acts on the condensing principle, and the heat given out by the steam, when admitted into the condenser, is employed to vaporize ether contained in surrounding chambers. As ether boils at a temperature of 100°, at which water is condensed very efficiently, the act of condensing one fluid vaporizes and gives expansive power to the other; and by using the ether vapour in a separate cylinder, and again condensing it in tubes cooled by sea water, a double action is obtained. Mr. Rennie had been requested to investigate the efficiency of the engine, and for that purpose he made a voyage in the vessel from Marseilles to Algiers, and back, accompanied by his son. The steam-boiler is adapted only for an engine of thirty horse power; and during the return voyage Mr. Rennie placed the coals under lock and key, so that he might ascertain exactly the quantity consumed. The result of his investigations was, that by the additional action of the ether vapour there was a saving of from 60 to 70 per cent.; and the amount of gain had been reported by a French commission, appointed to examine the engine, at 74 per cent. The loss of ether by leakage did not exceed in value one franc per hour during the voyage, and that might be greatly reduced by improved construction in the machinery. The French Government have paid the inventor a very large sum for the invention; and there are now several ships in course of construction to be propelled by engines of this kind; one of which is to be 1500 tons burthen, and the engines are to be of 150 horse power. Mr. Rennie said that arrangements are made for dispelling the ether vapour that escapes, so that there is no danger of its ignition.

Mr. Taylor, jun., the son of the engineer by whom the engine had been constructed, stated that there are several defects in it, which experience had pointed out, that would be remedied in those about to be constructed, so as to attain still better results. The surface of the condenser would be considerably enlarged in future engines.—Mr. Sykes Ward observed, that good ether does not corrode iron; therefore no objection to its employment could arise from that cause.—Mr. Fairbairn said that $2\frac{3}{4}$ lb. of coal per horse power are consumed in the best Lancashire engines, worked expansively, whilst the steam-boats on the Humber burn about 10 lb. of coal per horse power; and as it appeared from Mr. Rennie's report of the working of the combined steam and ether engine, that the duty was greater than that of the best Lancashire steam-engines, the advantage of the combined action, compared with that of the marine engines on the Humber, was very important.

"Report on the Mechanical Properties of Metals, as derived from repeated Meltings, exhibiting the maximum Point of Strength and the Causes of Deterioration," by W. Fairbairn.—The experiments on which this report was founded were undertaken at the request of the British Association. Mr. Fairbairn said that it was generally supposed that the strength of iron was deteriorated after three or four meltings, but the results of his experiments proved that opinion to be erroneous. The metal experimented on was Eglinton hot-blast iron, and the quantity was one ton. In melting the iron, the proportions of coke and flux were accurately measured, and proper precautions were taken to prevent any difference in strength from variations in cooling and casting. The metal was run into bars one inch square, lengths of seven feet were supported on two points, and weight was applied in the centre till the bars broke. It was found that the strength of the iron bars increased up to the twelfth melting, after which it diminished, and at each successive melting deteriorated rapidly. The breaking weight at the commencement was 403 lb., and the deflection of the bar before breaking was $1\frac{1}{2}$ inch; at the twelfth melting the breaking weight was 725 lb., and the deflection $1\frac{3}{4}$ inch; at the thirteenth melting the bar broke with a weight of 671 lb.; at the fifteenth, with 391; at the sixteenth, with 363 lb.; and at the seventeenth, with 330 lb. At that point the experiments were discontinued, as the quantity of iron had been so far diminished by waste and by reserving specimen bars, that no further trials would have been satisfactory. Mr. Fairbairn exhibited specimens of the bars at the various meltings. The fracture of the iron in the latter experiments presented a marked change. In the fifteenth melting there was a bright rim, like silver, surrounding the interior, which was of the usual crystalline structure. This bright silvery fracture extended in the sixteenth and seventeenth specimens, till it pervaded the mass, which then resembled cast-steel. Mr. Fairbairn said he intended to have the different specimens analyzed, to ascertain if the iron had undergone change in its chemical constituents, as well as in the arrangement of its molecules.

"An Account of some recent Improvements in the Manufacture of Rivets," by M. Samuelson.

"On Certain Improvements in the Construction of Steam-Ships, Life-Boats, and other Vessels; also in Steam-boilers, Propellers, Anchors, Windlasses, and in Metallic Casks," by R. Roberts.—The improvements in life-boats proposed by Mr. Roberts were noticed, with the description of other life-boats, in Monday's proceedings; the other inventions comprised in this paper have been previously described.

WEDNESDAY.

"On an Electric Semaphore for use on Railways," by W. Sykes Ward.—The object of the communication was to show that a semaphore, consisting of a disc, might be constructed to make a partial revolution, so as to take different positions, exhibiting three distinct signals; and that its motion might be regulated by electro-magnets, worked by a continuous supplemental battery, of which the circuit is opened, closed, and changed by an electro-dynamic coil, which is moved by means of a current communication from a distant station, through a single wire. Thus, what is mechanically effected at a distance of about half a mile, may, by the proposed apparatus, be effected at any required distance, and at any number of stations simultaneously.

"On a new Wheelbarrow," by Capt. F. Wilson.—In this harrow the wheel is placed under, and is sunk into the bottom; so that the weight rests on the wheel and not on the hand, and there is less oscillation. By means of this barrow, it was stated that twice the usual weight can be wheeled.

A discussion then followed on the paper by Mr. R. Roberts, "On certain Improvements in the Construction of Steam-Ships, Life-Boats, and other Vessels; also in Steam-boilers, Propellers, Anchors, Windlasses, and in Metallic Casks," read on a former day.

Mr. Forster (of the firm of Messrs. Forster & Andrews, organ-builders, in this town) gave a description of certain improvements in organ machinery, more particularly connected with the pneumatic lever, whereby greater facility would be given to the organist. He also introduced several pieces of machinery, likely to cause a complete revolution in the structure of that part of the instrument; others relative to the prevention of noise and friction, which latter had hitherto been an obstacle in the elasticity of the touch. During the subsequent discussion, Mr. Forster said, the late Mr. Booth, of Wakefield, invented and applied the pneumatic lever to organs for aiding in obtaining wind, in 1823; but the lever for the keys was not known till 1831, when Mr. W. Hamilton, of Edinburgh, and Mr. Barker, an Englishman, residing in Paris, simultaneously made the application.—Rev. W. V. Harcourt stated, that the organ there was so heavy to play, that the most admired anthems could only be got once or twice a year. The improvements, he believed, would obviate that difficulty. He had seen Dr. Camidge in a complete state of exhaustion from the manual labour some of those performances required.—The Chairman complimented Mr. Forster on the improvements exhibited.

"On an Improved Indicator for Steam-Boilers, and on a Safety Valve for Steam-Boilers," by J. Hopkinson.

At the conclusion of the business, the President took a brief review of the communications which had been made, particularly adverting to the reaping machines, the disc valve for steam-engines, the combined steam and ether engine, and the contrivances for facilitating water supply.

INSTITUTION OF CIVIL ENGINEERS.

NOVEMBER 8, 1853.

"On the Speed and other Properties of Ocean Steamers, and on the Measurement of Ships for Tonnage," by Mr. A. Henderson. The two subjects were combined, for the purpose of affording facility for their discussion.

After alluding to a paper brought before the Institution, in 1847, by the same author, in which the fallacy of using registered tonnage and nominal horse-power, as the index of the capabilities or speed of steamers was shown, by a comparison of their relative proportions and elements of resistance with the steam-power employed, the present paper referred to a tabular form, containing copious details of dimensions and of general information, as to the form, proportions, and speed realized by ocean steamers, compiled from documents, emanating from the department of the Surveyor of the Navy, and from returns made to Parliament by the Post-office and Admiralty; showing that, between the years 1845 and 1851, on an aggregate mail service of 1,271,000 miles, the speed realized, only averaged 7.945 knots per hour, which was far short of the speed generally supposed to be maintained by mail steamers; the highest speed being 8½ knots per hour, between Marseilles and Alexandria, by H. M. mail packets, and the lowest 7¼ knots per hour, between Ceylon and China, by contract steamers.

Reference was then made to a tabular statement, published by the committee on steam communication with India, showing the station of each steamer, including six packets of the Indian navy, running upwards of 325,000 miles, at a speed of 8.082 knots per hour, and eleven contract steamers of the Peninsular and Oriental Company, running above 533,720 miles, and averaging 7.972 knots per hour. By the same table, the speed of the iron steamer *Pekin* was shown to be 7.733 knots per hour; the older timber steamers, *Lady Mary Wood* and *Braganza*, realizing only 7.378 knots and 7.249 knots per hour respectively.

Some observations were offered on the various proportions, forms, and resistance of ocean steamers, and the difficulty of obtaining a fair criterion of relative efficiency; with suggestions, that the information might be obtained by recording the particulars required in the columns of a table, similar to the one which was exhibited, from which it appeared, that the proportions of vessels varied from five

and a quarter, to eight times their breadth to their length. That the length of the five steamers realizing 8½ knots per hour, averaged less than six times their breadth, while that of those which realized less than 7½ knots, averaged upwards of seven and a half times their breadth.

Reference was made to the *Oronoco*, one of the largest new steamers, the particulars of which afforded much useful information, and which, if similarly collected from other sources, and deposited in the archives of the Institution, would be most valuable, as the subject was daily becoming of greater interest and importance.

The second part of the paper was "On the Measurement of Ships."

By the old law, or huller's measurement, the length (less 3-5ths of the breadth) multiplied by the breadth, and the product by half the breadth, and divided by 94, gave the registered tonnage. By an act passed in 1836, and amended in 1845, a rule was adopted, based on the internal measurement of eleven breadths and four depths, taken at three sections, the divisor 3,500 giving the registered tonnage.

It was contended, that the present register of particulars, by omitting the depth, gave less information than the old register; that calculations of tonnage deduced from internal measurement, must show discrepancies of ten or even fifteen per cent. between the computed tonnage of timber and of iron ships, of the same size or external bulk; therefore it had become necessary to introduce a method of computation, deduced from both internal and external measurement, so as to combine the capacity for stowage, and the weight or the load, and the displacement. The principle being to ascertain the external bulk and internal space in cubic feet, and to deduce from the mean of these, by the use of a factor, 30, 31, or 32, a register of tonnage approximating to the old law, chiefly for statistical purposes; the external and internal dimensions in cubic feet giving the only correct definition of the size, capacity, and resistance of a vessel.

In 1849, the tonnage committee, including Mr. Parsons and Mr. Moorsom, reported that the equitable basis for charges was that of the entire cubical contents, measured externally, adopting a mode, originated by Mr. Parsons, of taking curves of areas of vertical sections, measured externally to the height of the upper deck; but these views were opposed, on the ground that iron vessels had much greater internal capacity than timber vessels of the same external measurement, and also on the assumption, that light or measurement goods exceeded in amount heavy goods, or dead weight; whereas, from the trade returns, No. 51, of 1850, it appeared, that of the total imports and exports, amounting to 10,760,217 tons, there were 7,483,214 tons of heavy goods, and 3,277,003 tons of light merchandise; thereby showing that a system, combining external and internal measurements, would be the most equitable.

Mr. Moorsom proposed a mode of computing the internal capacity, without the aid of diagrams or curves of areas, and of ascertaining the tonnage by dividing by 100, as more convenient. This new rule did not, however, give the burthen the vessel would carry, but merely the tonnage for an assessment of dues.

From both these propositions, the author of the paper dissented; considering it inexpedient to alter the present law, except to obtain a rule that should secure a correct mensuration and description of all kinds of vessels, so recorded on paper, as to give the size, form, and construction of the vessel. The plan he proposed would afford the means of correcting the measurement of sections, and would give facilities for forming a scale of displacement, and curves of internal areas, from which the weight of cargo, or capacity for light goods, could be obtained. Vessels being sold, and often freighted, at a price based on their bulk and capacity, and the materials, fittings, masts, sails, and engines, being all more or less regulated by these two qualities, it was expedient they should both be recorded on the builder's certificate, to be used, whenever required, by the officers usually employed in surveying ships, provided the mode of measurement and record was properly defined, exemplified by plans, and authorized by law.

The practicability of effecting this was shown, by the exhibition of a *pro forma* certificate of survey of a vessel, such as was proposed to be substituted for the usual builder's certificate, now required for registry; the directions for the measurement of the sections, and for striking the curves of areas, were given, and exemplified by diagrams, together with the rule and the processes of computing the external bulk and the internal space; the displacement and registered tonnage being thus given for three several vessels, built of timber only, of wood planking and iron frames, and entirely of iron; showing greater internal capacity of the two latter, as compared with the former.

By a specification of the materials for these three vessels, the weight of the hull of a timber ship was shown to be 184 tons, that of iron 148 tons, and of iron frames and wood planking 158 tons, the latter being represented as an arrangement of materials, by which the author proposed to obtain the lightness and capacity of an iron ship, without the danger of corrosion and of undue action on the compasses.

These propositions, like Mr. Moorsom's, had been submitted to the Board of Trade, with the view of suggesting the reorganization of the tonnage committee, and the addition of members connected with shipping and with scientific societies, so as to promote free discussion and the diffusion of information, and to obtain experience, conducing to the improvement of the mercantile marine, fishing-boats and life-boats.

The necessity for the co-operation of all engaged in maritime enterprise, was urged from the experience of the limited improvement, hitherto made in fishing-boats and life boats, reference being made to the circumstances of the failure of the prize model life-boat; concluding with a proposition that the Admiralty should provide each coast guard station with one of their model life-boats, and that a mercantile marine association should be formed, for the prevention of loss from shipwreck, an end which could only be attained by the improvement of the forms and fittings of vessels and boats.

MONTHLY NOTES.

PROGRESS OF SCREW PROPULSION.—MARINE MEMORANDA.—We last month recorded the very successful performance of the *Argo*, General Screw Steam Company's ship, on her outward voyage to Port-Philip. Since that time, her homeward trip has extended the good opinions of her qualifications. What she has done is best told in the fact, that she has made a voyage round the world in the short space of five months and 19 days, and of this time upwards of six weeks were spent in Anstralin. The actual time under steam and canvas has been only 121 days; the total distance run out and home has been 27,000 miles; giving an average per day of nearly 230 miles, or slightly over $9\frac{1}{2}$ miles per hour. Steam power has only been used as an auxiliary, when the winds happened to be light or adverse. The consumption of coals during the whole passage has therefore only amounted to 2,105 tons, of which 845 tons were expended outward, and 1,260 tons homeward, giving an average of rather more than 17 tons per diem. Owing to these ships being fully rigged, the greatest advantage can at all times be taken of favourable winds, and the steam power is, during these circumstances, completely dispensed with. In the present voyage, with fair winds and with all canvas set, the *Argo* has made 13 and 14 knots an hour for days together, and close-hauled 11 to 12 knots, in both cases with the screw feathered. The *Argo's* feathering apparatus seems to have answered particularly well, no appreciable impediment having occurred when under canvas alone.

Something is being said of a steamer, at present being built at New York, to cross the Atlantic in less than a week. Mr. Norris, of Philadelphia, is her constructor, and he guarantees six days' voyages even in winter. Her engines and boilers are on the same general plan as those of the Cunard and Collins lines; but the engine power, in proportion to the hull tonnage and draught of water, is to be five times greater than in any steamer now afloat. Her draught of water is only 6 feet 6 inches.

The splendid performances of the *Flying Cloud*, and, after her, the *Sovereign of the Seas*, have acted as a powerful incentive to further exertions on the part of their builder, Donald Mackay. The *Flying Cloud*, on one occasion, sailed 374 geographical miles in the twenty-four hours; then the *Sovereign of the Seas* hedimmed this triumph, by accomplishing 430 miles in the same time. But the *Great Republic*, a still larger ship, is intended to do still greater things. She is 4,000 tons burden, and in her construction 1,500,000 feet of hard pine have been used, 2,056 tons of hard oak, 336½ tons of iron, and 56 tons of copper for bolts, exclusive of sheathing. She will spread 16,000 yards of canvas, with four masts. A new feature on board is a steam-engine of 15 horse power; this is intended to do all the heavy work of the ship, such as hoisting in and discharging cargo, setting up rigging, hoisting topsail; it is also connected with an apparatus for distilling fresh water from salt water. It will also diminish the number of men required to work the ship, her crew consisting of only 100 men and 30 boys. The keel, for 60 feet forward, is gradually raised from a straight line, and curves upwards into an arch, so that the gripe of the fore foot is the arc of a circle, and not angular, like other vessels. The lines are concave forward and aft, up to a few feet above the load-displacement line; the sides are arched, something like a man-of-war, but not so much in proportion to her size; the stern is semi-elliptical in form, and, instead of hullwarks, the outline of her spar-deck is protected by a rail, supported by turned oak stanchions. She has four complete decks, and four houses on her spar-deck erected for the use and comfort of the crew. Her mainmast and foremast are 44 inches in diameter, the mainyard 28 inches, and 120 feet long, carrying a sail 120 feet square. She is just now fitting out for sea, and nautical men will look with interest for her log.

An accident, powerfully illustrative of the necessity of fitting governors to screw-propeller engines, occurred the other day at Plymouth, on board the *Agamemnon*. This vessel was steaming at the time, outside the Sound, for the purpose of testing her Griffiths' screw. When two miles from the breakwater, steaming $8\frac{1}{2}$ knots, and making 45 revolutions per minute, something gave way below, and the revolutions seemed to be suddenly increased to 1,000 or more per minute. The shock is described to have been similar to that of an earthquake. The funnel appeared to jump from its place, and so excessive was the vibration, that every one expected the masts would go over the side, and the boilers were momentarily expected to burst. At this critical juncture, Mr. Langley, with great nerve and coolness, threw open the valves, gradually stopped the engines, and thus saved the valuable machinery from tearing itself to pieces, and injuring, if not destroying, the noble vessel herself. She was immediately put under canvas, and returned to the Sound. On subsequent examination, it appeared that the main shaft was broken just within the fans—in all probability from a defect in the metal. A diver went down and made an inspection again on Thursday morning. It seems to be a subject for con-

sideration, whether experiments of this kind should not be confined at first to ships of less size than the *Agamemnon*, which is in all other respects complete for sea service.

BENTALL'S SELF-REGISTERING DYNAMOMETER FOR PLOUGHS.—This apparatus, specially contrived for testing the draught of ploughs, is shown in perspective, complete, in our annexed sketch. It consists of an iron frame on four travelling wheels, a strap from the nave of one of which drives a pulley on one end of a metal disc spindle. This disc, which revolves in a vertical plane, acts as a driver for a small surface-wheel, bearing by its periphery upon the disc face, and capable of being traversed nearer to or further from the disc's centre. The pull of the horses, in drawing the plough, compresses a pair of helical springs, and, by means of a connection between these springs and the edge-wheel of the disc, a constant

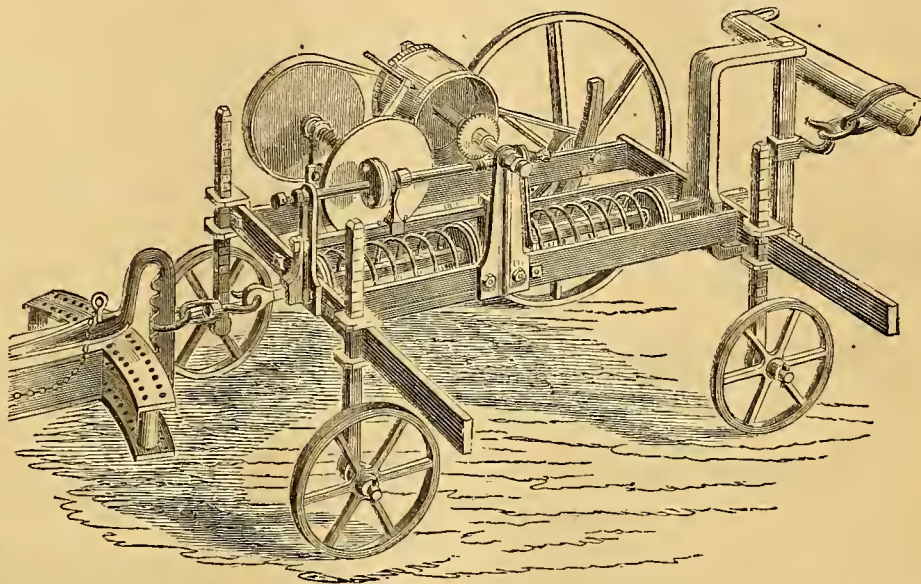

relation is preserved between the actual compression of the springs, and the distance of the edge-wheel from the centre of the disc. Hence the wheel is driven faster or slower, just as the draught-spring compression is greater or less. The edge-wheel spindle carries a worm, working into a worm-wheel on a cross shaft, carrying a drum, and it is this drum which carries the diagram paper for the tracing pencil. Motion is given to this pencil in a direction parallel to the axial line of the drum, by means of a screw on the disc spindle, and the motion in this direction indicates the length of furrow drawn. The two motions combined cause the pencil to describe a diagonal, showing the variations of the draught during the experiment, the traced line becoming more nearly parallel with the axis of the drum as the draught is less. A brass wheel, with a graduated edge, also revolves with the drum, to indicate the draught in stones, when a determined length of furrow is drawn. In this arrangement of dynamometer, no special means are necessary for obviating the vibratory motion commonly interfering with the action of instruments of this class. The power which moves the drum acts uniformly in one direction, and the only effect produced on the drum by variation of draught, is simply increase or diminution of speed. The instrument is indeed its own tell-tale throughout its entire working.

STENSON'S IMPROVEMENTS IN SCRAP-IRON FORGING.—An important improvement upon the process of working up scrap-iron is now in active operation at the "Patent Iron Scrap Forge Works, Northampton," under the active superintendence of Mr. Stenson, the patentee. In this establishment, the scraps and cuttings of wrought-iron, collected from all parts of the country, are worked up in the puddling furnace into puddled balls, from which the primary rolling process produces rough or puddled bars. Such bars are then cut up into short lengths, and the several pieces are laid one upon the other, to form a "pile," with a series of which the puddling furnace is now charged. When these piles are at a welding heat, they are severally withdrawn, and rolled out into bars for use, or for cutting, and re-rolling, and rolling, as may be intended. According to this general process, the welding hot piles have to be conveyed a considerable distance through the cold air to the rolls, and hence oxidation of the welding surfaces, and cooling of the mass, render the metallic junction of the parts very imperfect. Mr. Stenson removes this difficulty, by fitting a mechanical hammer to the door of each of his puddling furnaces, in such manner that he can apply a hammering weld to the pile at the moment that the mass leaves the furnace. In the actual arrangements, which we have seen at work in Northampton, the hammer movement is derived from an overhead counter-shaft, driven by the rolling-mill engine. On this shaft is a short end-crank, from which a rod, carrying a lifting catch—like the "plug-frame" of old-fashioned steam-engines—descends to a stud on the hammer lever, which works on an end stud centre, carried by the furnace side-plates. This rod is not confined to a mere vertical traverse action. It has, at its lower end, a

spring link, which constantly tends to press it up to a stationary bearing pulley, as a fulcrum on which to oscillate. When the furnace door is raised for the withdrawal of a welding pile, the latter is drawn upon an anvil on a level with the beating floor, and just outside the door, and the hammer lifting-rod pushes back an engaging catch, and permits the hammer to fall upon the heated pile, striking one or more blows at pleasure. This produces a most effectual weld, so that, when rolled out, the ends of the piled pieces do not get overdrawn, as is usually the case. This feature alone is of some value in the process, as the working of the ends, one over the other, ordinarily involves the cropping of about a foot of the rough ends at the shears to get a clean bar. The general quality of the iron made in this way is said to be improved by some 20s. a ton. The "iron sand," from the sea-coast of New Zealand, is about to receive a working test at the Northampton forge. This material, which is found in great abundance on the sea-coast, is a titanite protoxide of iron, highly magnetic, of great density, and contains 70½ per cent. of iron. It is expected that it will be turned to account as a raw material for Sheffield steel.

BORIE'S CELLULAR ROOFING TILES.—Messrs. Norton and Borie, whose successful efforts in the manufacture of cellular bricks were substantially rewarded by the Great Exhibition jury, in 1851, have now established extensive works in this country for the construction of brick and tile machinery of all kinds. Since we examined their productions in the French department of the Exhibition,* their cellular system has been elaborated to a still greater extent, and amongst other novelties they have introduced tubular or hollow roofing tiles. These tiles

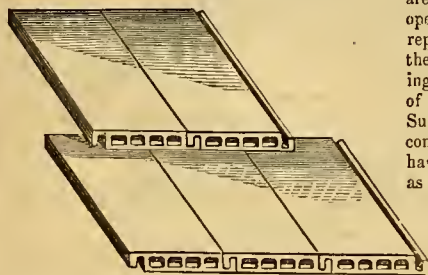

are made both with closed and open ends. Our illustration represents the latter class, as they lie upon the roof, holes being run through the thickness of the tile, just as in a brick. Such tiles are excellent non-conductors, so that the sun's rays have very little power upon them, as the external surface only becomes heated, further transmission of heat being intercepted by the stratum of air inside. They are also efficient ventilators, admitting

the external air in the safest manner, in streams running upwards in the direction of the roof's slope. Besides these advantages, they possess a further one in diminished liability to leakage; for, if the outer plate gets fractured, there is still the inner one to carry off the rain. The upright partitions give great strength, whilst a roof so covered is lighter than any other. The manufactory, "Union Works, New Park Street, Southwark Bridge, London," is organized on the most extensive scale for the production of all varieties of clay-working machines.

DEEP SEA SOUNDING.—Hitherto a continuous series of deep sea soundings has been rendered difficult by the fact, of each sounding costing the exploring ship a new line, for however strongly the line has been made, when once out, it has never been recovered. But Lieut. Maury has adopted a simple plan for avoiding this loss, by contriving a detaching apparatus for his sounding weight, so that on reaching the bottom the line may easily be drawn up. A hole is drilled through a 64 lb. or heavier shot, sufficiently large to admit of a rod of about three-quarters of an inch in diameter. This rod is about 12 or 14 inches in length, and, with the exception of about 1½ inch at the bottom, perfectly solid. At the top of the rod are two arms extending, one from each side. These arms being upon easily acting hinges, are capable of being raised or lowered with very little power. A small branch extends from the outside of each of them, which is for the purpose of holding, by means of rings, a piece of wire by which the ball is swung to the rod. A piece of rope is then attached by each end to the arms, to which again is joined the sounding line. The ball is then lowered into the water, and upon reaching the bottom the strain upon the line ceases, and the arms fall down, allowing the ball to detach itself entirely from the rod, which is then easily drawn in—the drilled portion being discovered to be filled with a specimen of that which it has come in contact with at the bottom.

PRINTING NEWSPAPER STAMPS IN THE FORMS.—The red penny stamp has disappeared from the lower corner of the "Times" newspaper, and the words "The Times newspaper one penny," are now printed in common ink at the upper left-hand corner of the title-page. Mr. C. B. Clough, of Tyddyn, Mold, lays claim to the origination of this simple but important change. His proposal was to insert the die of the government stamp, in the form with the rest of the type, like a woodcut, the actual number of impressions thrown off being registered on a dial attached to the press, as in a railway ticket machine. This is exactly what is now being done in the "Times" office. It is really marvellous that the troublesome and expensive system of the separate stamping at Somerset House should have been practised so long. Until lately, even this roundabout process was performed by hand. It is only quite recently that Mr. De la Rue's ingenious mechanical stampers have been introduced.

RAISING SUNK VESSELS BY BOUYANT GAS.—An ingenious mode of raising sunk vessels, patented in this country by Mr. J. H. Johnson for the inventor, Mr. Foreman, of New York, has just been successfully tried in that city. The inventor's plan is to generate, by a simple process, a cheap gas, which is passed down through flexible tubing to "camels," or buoyant reservoirs, attached to the vessel to be raised. In the New York experiments, a weight of 3 tons was raised 30 feet in

40 seconds. If flexible gas receivers or bags are used instead of the common wooden camels, the entire apparatus for lifting a tolerably large vessel can be stowed in a box of 6 feet cube. In some cases, the hold or tween decks of the sunk vessel itself may be made to answer as the gas receiver, by making a hole in the vessel's bottom for the outflow of the contained water as the gas enters, with the upper portion as nearly air-tight as possible. The contrivance is also suitable for military pontoons. A company has been started to carry out the plans in America.

ELASTICATED COTTON FOR BEDS.—A company has been organized in the United States, for giving a peculiar elasticity to cotton in its loose unmanufactured state, and the results of the operations promise to create a large demand for the raw material in quite a new direction. It is as a material for beds that this cotton, so prepared, is particularly intended, cotton costing in America from 6 to 10 cents a pound, against feathers at from 40 to 60 cents. The purity of cotton, and its entire freedom from all offensive odours, are points in its favour in other respects, so that the elasticated cotton must inevitably come into common use. The articles at present made from it are termed felt mattresses. In a domain known as *la Prairie de Humboldt*, not far from Breslau in Silesia, is a factory where the leaves of the *Pinus Sylvestris* are converted into a textile wool. The process is a chemical one, the invention of M. de Pannelvitz, the head inspector of forests, producing a long filamentous substance, which has been termed "wood wool," and is capable of being curled, felted, and spun like animal wool. The leaves are stripped from the trees every two years. When gathered, heat is applied to them, in conjunction with certain chemical reagents, and the resinous matter which holds the constituted fibres together is thus dissolved out. The fibres can then be separated, when they are washed and classed as coarse or fine. The course is applied to the same purpose as the elasticated cotton, the filling of mattresses; the finer kind is used as wadding. As a wadding for quilted coverlets, the pine-wool answers admirably, and it is regularly used in the Austrian hospitals, where the aromatic odour emitted by it has been found to be pleasant and beneficial. It also prevents the harbouring of parasitic insects. The liquid residuum of the boiling operation exercises a very salutary influence as a bath, and a bathing establishment has accordingly been added to the manufactory. Finally, advantage is taken of the production of oils and acids, and a resinous fuel, in still further economizing the pine.

RENSHAW'S SECONDARY ADJUSTMENT DRAWING-PEN.—Our illustration annexed, represents a modification of the common drawing-pen, submitted to us by Mr. G. P. Renshaw. In it, the screw, A, adjusts the back-line width, as usual; and the additional one, B, sets the face-line. The spring is a little stronger



than usual, and, when the artist wants a fine line, he grasps the pen correspondingly harder. The inventor states that this plan of working soon becomes a habit. His own experience proves that much time may be saved by its adoption.

QUALITY OF LONDON GAS.—Dr. Letehy's last report to the Commissioners of Sewers, on the illuminating qualities of the Great Central Gas Consumers' Company's gas, as deduced from 120 different experiments, shows:—1. When the gas has been burnt from an argand of 15 holes, according to the Act of Parliament directions, it has furnished a light which, on the average, has been equal to 13.9 sperm candles, or 15.9 wax, each consuming 120 grains of combustible matter per hour. 2. When the gas has been burnt from a batwing jet at the rate of 4 cubic feet per hour, its light has been equal to that of 9.6 sperm candles, or 10.3 wax; and when consumed, from the same jet, at the rate of five cubic feet per hour, its average luminosity has been equal to that of 11.8 sperm, or 13.5 wax. These results show that the gas has been of good illuminating power; in fact, they prove that it has been rather more than 31 per cent. better than that required by the Act of Parliament. The chemical quality of the gas has been of an average description.

ROLLING STOCK ON BRITISH RAILWAYS.—The total number of locomotive engines on railways in the united kingdom is 3,942, being about one locomotive to every two miles of railway; the number of first-class carriages 2,413, capable of holding 49,226 passengers; the number of second-class carriages 3,413, capable of holding 124,703 persons; the number of third-class carriages 2,954, capable of holding 121,807 persons; the number of composite carriages 1,114, capable of holding 35,239 persons; and the number of other carriages 1,470, capable of holding 4,231 persons—making together 11,364 carriages, capable of holding 335,206 passengers. The number of horse-boxes is 1,547, capable of holding; 4,547 horses; the number of cattle-waggons 7,127, capable of holding 76,696 head of cattle. The number of carriage trucks is 1,561. Of the 3,942 locomotive engines, 3,221 are used on railways in England and Wales, 527 on railways in Scotland, and 194 on railways in Ireland. Of the 2,413 first-class carriages, 1,967, capable of holding 40,005 persons, are on railways in England and Wales; 346, capable of holding 6,252 persons, on railways in Scotland; and 100, capable of holding 2,969 persons, on railways in Ireland. Of the 3,413 second-class carriages, 2,846, capable of holding 104,811, are on railways in England and Wales; 396, capable of holding 10,930 persons, on railways in Scotland; and 171, capable of holding 8,962 persons, on railways in Ireland. Of the 2,954 third-class carriages, 2,204, capable of holding 93,235 persons, are on railways in England and Wales; 543, capable of holding 17,743 persons on railways in Scotland; and 210, capable of holding 10,829 persons, on railways in Ireland. Of the 1,114

* See page 219, part 46, vol. 4, *Practical Mechanic's Journal*.

composite carriages, 822, capable of holding 26,635 persons, are on railways in England and Wales; 210, capable of holding 4,846 persons, on railways in Scotland; and 82, capable of holding 3,758 persons, on railways in Ireland. Of the 1,470 other carriages, 1,305, capable of holding 2,961 persons, on railways in England and Wales; 101, capable of holding 820 persons, are on railways in Scotland; and 64, capable of holding 450 persons, on railways in Ireland. Of the 1,547 horse-boxes, 1,282, capable of holding 3,751 horses, are on railways in England and Wales; 162, capable of holding 486 horses, on railways in Scotland; and 103, capable of holding 310 horses, on railways in Ireland. Of the 7,127 cattle-waggons, 5,892, capable of holding 67,319 head of cattle, are on railways in England and Wales; 745, capable of holding 5,423 cattle, on railways in Scotland; and 490, capable of holding 3,954 cattle, on railways in Ireland. The number of carriage trucks on railways in England and Wales is 1,311, in Scotland 165, and in Ireland 85.—On the broad, or 7-foot gauge lines, the working stock consists of 239 locomotive engines; 197 first-class carriages, capable of accommodating 5,880 persons; 259 second-class carriages, capable of holding 17,150 persons; 71 third-class, capable of holding 4,632 persons; and 44 composite carriages, capable of holding 2,029 persons; 168 horse-boxes, capable of holding 647 horses; 1,492 cattle-waggons, capable of holding 11,699 cattle; 230 carriage trucks, and 103 vans.—On the narrow, or 4-foot 8½ inch gauge lines, in England and Wales the working stock consists of 2,982 engines; 1,770 first-class carriages, capable of holding 34,125 persons; 2,578 second-class carriages, capable of holding 87,661 persons; 2,133 third-class carriages, capable of holding 88,603 persons; 778 composite capable of holding 24,606 persons; 1,202 other carriages, capable of holding 2,961 persons; 1,114 horse-boxes, capable of holding 3,104 horses; 4,440 cattle waggons, capable of holding 55,620 head of cattle; and 1,081 carriage trucks. They are all narrow gauge lines of 4 feet 8½ inches in Scotland; the gauge of railways in Ireland is 5 feet 3 inches.

HARRISON, RADCLYFFE, & BLUNT'S "KITCHENERE."—Amongst the important novelties in domestic fittings, shown at the Dublin Exhibition, is an excellent and economical "Kitchenere," made by Messrs. Harrison, Radclyffe, & Blunt, of the Eagle Foundry, Leamington. Our engraving represents this range in front perspective elevation. It consists of a hot-plate, A, whereon a number of vessels may be conveniently kept boiling, whilst the heated surface also answers as an ironing-stove. On one side is a well-ventilated and spacious wrought-iron roaster, B, with moveable shelves, draw-out stand, double dripping-pau, and meat

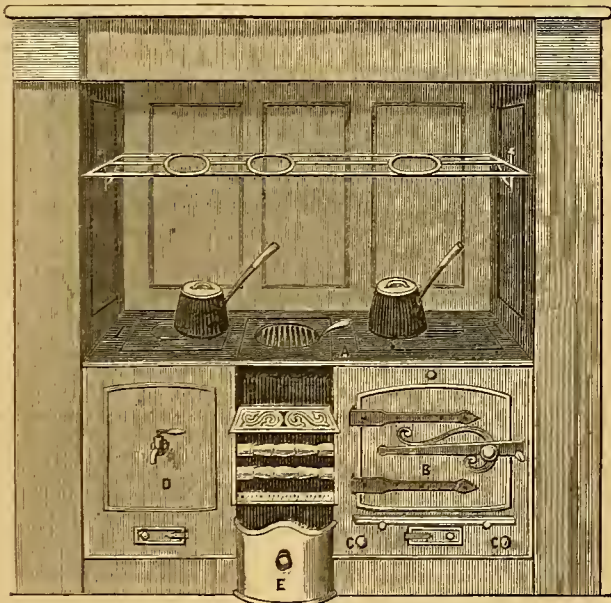

stand; and this roaster is at once convertible into an oven by closing the valves, C. On the other side is a wrought-iron boiler, D, with brass tap and steam-pipe. In the centre is an open fire for roasting, and general domestic purposes; this is fitted with an ash-pan, E. Above, are round and square gridirons; whilst a set of ornamental covers, with plate warmer attached, make the range complete. The heat from the fire is most economically applied—the currents having to pass all round the oven, and behind, and up the sides of back boiler, before they can escape. We have before us other forms of the arrangements, on a still more extensive scale. By the aid of one fire, three cooking ovens may be heated on each side, in addition to the supplying steaming closets from the boiler.

PROVISIONAL PROTECTIONS FOR INVENTIONS UNDER THE PATENT LAW AMENDMENT ACT.

When the city or town is not mentioned, London is to be understood.

Recorded June 16.

1464. Jules A. A. Dumoulin, Paris, and 16 Castle-street, Holborn—An improved instrument for measuring and tracing.

Recorded August 1.

1794. Samuel C. Lister, Manningham, Yorkshire—Improvements in machinery for washing wool and hair.

Recorded August 5.

1831. William Smith and Thomas Phillips, Snowhill—An improvement in gas stoves.

Recorded August 9.

1851. Thomas Y. Hall, Newcastle-upon-Tyne—Improvements in safety-lamps, part or parts of such improvements being applicable to the consumption or prevention of smoke, and for the purposes of ventilation generally.

Recorded August 10.

1861. Alexander Prince, 4 Trafalgar-square, Charing-cross—Invention of a press, applicable to the several purposes of lithography, autography, typography, chromolithography, or printing in colours, copperplate printing, cylinder printing, embossing, and copying letters.—(Communication.)

Recorded August 12.

1888. William L. Tizard, Aldgate—Invention of a new combination, or new combinations, of materials suitable for buildings and other structures, and parts thereof, and machinery for producing the same.

Recorded August 17.

1923. Felix A. V. Delarbre, 9 Broad-street Buildings—Certain improvements in treating fibrous substances.

1926. Thomas Grimley, Oxford—Improvements in machinery for the manufacture of bricks, tiles, pipes, and pottery.

Recorded August 20.

1949. Alexander Cunningham, Glasgow—Improvements in the manufacture or production of alkalies and their salts, or alkaline salts.

Recorded August 27.

1993. Samuel Taylor, 53 King-street, Manchester—Improvements in apparatus for generating and applying carbonic acid gas.

Recorded August 30.

2006. Charles Goodyear, Avenue-road, St. John's-wood—Improvements in the manufacture of waterproof fabrics.

Recorded September 5.

2042. John Clare, jun., Liverpool—Improvements in the construction of iron houses, vessels, masts, spars, smoke funnels, boilers, cylinders, beams, and other like structures or articles.

Recorded September 6.

2054. Alfred Sommerville and Charles Twigg, Birmingham—Improvements in pen-holders, and which said improvements are applicable to the manufacture of umbrellas and parasol sticks, cornice poles, and other such like articles.

Recorded September 8.

2065. Robert Harrington, Witham, Essex—Improvements in umbrellas and parasols.

Recorded September 9.

2072. Jonas Radford, Cheltenham—Improvements in clocks or time-keepers.

Recorded September 16.

2156. Francis B. Newton, Manchester—Improvements in the mode or method of cutting and making up garments, so as partially to dispense with seams or sewing.

Recorded October 1.

2242. Charles Coates, Sunnyside, Lancashire—Improvements in coupling pipes, and other articles, and in apparatus connected therewith.

2244. Edward Davies, Bradford—Improvements in carrier-combs, to be used in combing wool, cotton, silk, flax, or other fibrous substances.

2246. John Findry, Glasgow—Improvements in ovens and apparatus for baking.

2248. Samuel Muriand, Castlewellan, Ireland—Certain improvements in machinery for preparing linen yarn.

2250. Adolphe Drexelle, Halifax, Yorkshire—Improved apparatus to be used in connection with looms for weaving.—(Communication from Messrs. Ryo and Praxel, Roubaix, France.)

2252. William Brown, Bradford—Improvements in apparatus used in washing wool and other fibrous material.

Recorded October 3.

2254. John W. Baxter, Mistley, Essex—Certain improvements in shipbuilding.

2256. James Coleman, 4 South-street, Finsbury—Improvements in the construction of compasses.

2258. William H. Wilding, Chesterfield-street—Improvements in propelling machinery.

2260. William Crofts, Derby-terrace, Nottingham-park—Improvements in weaving.

Recorded October 4.

2262. William Peace, Haigh, near Wigan—Invention of hewing and excavating coal, coal, and other minerals, strata, and substances, by certain machinery and appliances thereto.

2264. John Norton, Cork—Improvements in firing explosive compounds.

2266. Joseph T. Dodge, St. Astell, Cornwall—Improvements in the formation and arrangement of, and mode of rigging and working the sails of yachts, ships, and other vessels.

2268. Daniel T. Shears, Bankside, Southwark—Improvements in brewing.

2270. James L. Norton, Ludgate-hill—Improvements in instruments or apparatus for measuring and indicating the distance travelled by carriages, and in the means of transmitting motion thereto from the running wheels.

Recorded October 5.

2274. James T. Wilson, Falkirk—Improvements in the manufacture of alum.

2280. William L. Tizzard, Aldgate—Improvements in thermometers and other like indicators.

Recorded October 6.

2282. Julius Schönemann, 89 Great Portland-street, Middlesex—Invention of new construction of weighing-machines.—(Communication.)

2286. Alfred E. Hargrove, York, and Ralph Richardson, Hartlepool—Improvements in machinery or apparatus for printing.

2288. William Geeves, New Wharf-road, Caledonian-road—Improvements in the manufacture of hicks.

Recorded October 7.

2292. William Ellis, Sheffield—Improvements in the manufacture and in the ornamenting of china, porcelain, and pottery wares.

2294. James Ferguson, Glasgow, and James Lillie, same place—Improvements in trousers and similar articles of dress.
2295. John H. Johnson, 47 Lincoln's-inn-fields, and Glasgow—Improvements in apparatus for compressing or rarefying air or other elastic fluids.—(Communication from Germain Sommeiller, Turin.)
2296. Joseph Porter, Salford, Lancashire—Improvements in machines for drilling or boring metals or other substances.
2297. John Onions, 3 Park-terrace, and Samuel Bromhead, Marlborough Estate, both of Peckham, Surrey—Certain improvements in steam-engine boilers.
2298. William J. Matthias and Thomas Bailey, Seckford-street, Clerkenwell—Improvements in obtaining power by mechanical means.
2299. Thomas Lambert, Short-street, Newcut, Lambeth—Improvements in ships' water-closets.
2300. Robert J. Corlett, Monmouth—Improved machinery for preparing or scutching flax, and other fibrous materials requiring such an operation.—(Communication from Mr. Benjamin Delattre, Setques, France.)
2301. Francis Whitehead, Crayford, Kent, and William Whitehead, same place—Improvements applicable to lanterns, lamps, lamp-shades, and reflectors, for reflecting, concentrating, or diffusing light.
- Recorded October 8.*
2302. Alexander E. D. K. Archer, 1 Wharf-road, City-road—Improvements in apparatus for applying metallic capsules.
2304. Henry Kraut, Zurich, Switzerland—Improvements in stands for casks and barrels.
2305. Joseph Denton, Prestwite, near Manchester—Improvements in looms for weaving.
2306. H. Dubs, Vulcan Foundry, Warrington—Certain improvements in the manufacture of wheels and tyres, and also in the construction of furnaces employed in such or similar manufactures.
2307. William Wilkinson, Nottingham—Improvements in protecting telegraph wires.
2308. George L. Smart, Enfield, Middlesex—Improvements in vessels for preserving loaches and fish alive.
2309. William Potts, Birmingham—Improvements in mantelpieces.
2310. Henry R. Plimpton and James L. Plimpton, Massachusetts, U.S.—Invention of a new and useful article of furniture, to serve the purposes of a bedstead, a toilet table, or a washstand and a writing desk.
2311. Charles May and James Samuel, Great George-street, Westminster—Improvements in joining the ends of the rails of railways.
2312. Henry Clayton, Upper Park-place, Dorset-square—Improvements in the manufacture of bricks and tiles.
2313. William E. Newton, 66 Chancery-lane—Improvements in fire-arms and cartridges.—(Communication.)
- Recorded October 10.*
2314. Robert J. Maryon, 37 York-road, Lambeth—Improvements in the construction of anchors.
2315. Henry Rawson, Leicester, and Thomas Whitehead, same place—Improvements in regulating the flow of air to steam-boiler furnaces.
2316. George F. Wilson, Belmont, Vauxhall—Improvements in treating wool and fabrics composed of wool.
2317. George F. Wilson, Belmont, Vauxhall—Improvements in the manufacture of candles and night-lights.
2318. George F. Wilson, Belmont, Vauxhall—Improvements in the manufacture of soap.
2319. Frederick Warner, Crescent, Jewin-street, and John Shotton, same place—Improvements in the manufacture of large hells.
2320. Richard A. Brooman, 166 Fleet-street—Improvements in railway switches.—(Communication.)
2321. Hugh L. Pattison, Scot's House, near Gateshead—Improvements in the manufacture of sulphuric acid.
- Recorded October 11.*
2322. James Knowles, Eagle Bank, near Bolton-le-Moors, Lancaster—Improvements in machinery for regulating the velocity of steam-engines, and other motive power engines.
2323. Henry Kemp, Barkam-terrace, Southwark—Certain Improvements in the preparation of wood for sheathing ships, as a substitute for copper and other metals, also in house, ship, and pier building, &c.
2324. William Wilkinson, Nottingham—Improvements in bands, belts, and straps.
2325. Louis A. F. Demoulin, Paris—Improved apparatus applicable to carriages on common roads, for the prevention of accidents, and increasing the power of locomotion.
2326. William Beardmore, Deptford, and William Rigby, Glasgow—Certain improvements in steam-engines.
2327. David Dick, Paisley—Improvements in the manufacture of flexible tubes or pipes.
2329. James Worrall, jun., Salford, Lancashire—Certain improvements in the method of dyeing fustians and other textile fabrics, and in the machinery or apparatus connected therewith.
2331. James H. Nalder, Alvescott, Oxfordshire, and John T. Knapp, Clanfield, same county—Improvements in winnowing or dressing corn.
2332. William M. Campbell, Glasgow—Improvements in earthenware kilns.
2333. James Harris, Hanwell—Improvements in apparatus for heating water and other fluids.
2334. William H. Muntz, Massachusetts—Improvement in paddle-wheels for navigable vessels.
2335. James Webster, Leicester—Improvements in water gauges for steam-boilers.
2336. John F. Porter, Bessborough-street—Improvements in the moulding of bricks, and other articles of like materials.
2337. Bernard Couvan, Fenchurch-street—Improvements in giving signals on railways.
- Recorded October 12.*
2338. George F. Goble, 15 Fish-street-hill—Improvements in apparatus for signaling and stopping railway trains.
2339. John Morison and Daniel Hurn, Norton Folgate—Improvements in the manufacture of nose-bags.
2341. Patrick Clark and Alexander Clark, Gate-street, Lincoln's-inn-fields—Improvements in revolving shutters and other closures for portable and other buildings.
2342. Thomas Smith, Lambeth—An improved method of making pipes.
2343. Edme J. Maumene, Reims, France—Improvements in the treatment of lignite or wood coal, and in obtaining various useful products therefrom.
2345. Henry Mapple, Child's-hill, Hendon, and Daniel M. Mapple, 16 Sidney-street, Islington—Invention for electric telegraphic purposes, being an improved printing and signal electric telegraph, with electric alarm attached.
2346. George Bradley, Castleford, Yorkshire—Improvements in stoppers or covers for bottles, and in the tools or apparatus for manufacturing the same.
2347. James Higgins and Thomas S. Whitworth, Salford—Improvements in machinery or apparatus for spinning and doubling fibrous materials.
2348. Charles S. Jackson, Cannon-street—Improvements in preserving seeds, potatoes, and other roots.
2349. John Gibson, Bloomfield-road, Paddington—Improvements in fixing tyre on railway wheels.
2350. Charles S. Jackson, Cannon-street—Improvements in preserving timber and other vegetable matters.
2351. Richard Jones and Charles J. Jones, Ipswich—Improvements in fire-arms.
- Recorded October 13.*
2352. Henry W. Butterworth, Philadelphia—An improved supplemental reflux valve for steam-engines.—(Communication.)
2353. William M. Campbell, Glasgow—Improvements in potters' or earthenware kilns.
2354. Robert Popple, Beverley, York, and Henry Woodhead, Kingston-upon-Hull—Improvements in machinery for slubbing, roving, and spinning cotton and other fibrous substances.
2355. John Elce, Manchester—Improvements in machinery for preparing and spinning cotton and other fibrous substances.
2356. William Robinson, Manchester—Improvements in machinery or apparatus for manufacturing or forging iron or other metals into screw bolts, nuts, rivets, pins, studs, or other similar articles.
2357. Sir John S. Lillie, 4 South-street, Finsbury—Improvements in machinery for breaking stones and other hard substances.
2358. John T. Way, Holles-street, Cavendish-square—Improvements in making and refining sugar, and in treating saccharine fluids.
2359. Abraham Pope, 81 Edgware-road, Middlesex—Improvements in furnaces.
2360. Joseph Piper, Shoreditch, Middlesex—Improvements in apparatus for affixing adhesive stamps and labels.
2361. Charles L. A. Meinig, 103 Leadenhall-street—Improvements in galvanic batteries.
2362. Thomas Grabame, Hatton-ball, Wellingborough—Improvements in building ships and other vessels.
- Recorded October 14.*
2365. Samuel Bromhead, Marlborough Estate, Peckham, Surrey—Improvements in emigrants' and other portable houses and erections, and hinges of metal suitable to all purposes requiring hinges.
2366. Andrew M'Lean and William F. Rae, Edinburgh—Improvements in apparatus for the manufacture of acrated liquids.
2367. William Ridgway, Hanley, Stafford—Improvements in the construction of ovens and kilns.
2368. Mary Ann Davy, Homerton, and Ann Taylor, Islington, both in the county of Middlesex—Improvements in the mechanical application of brushes.
2369. William Palmer, Brighton—Certain improvements in ventilating.
2370. William E. Newton, 66 Chancery-lane—Improved machinery for preparing and combing wool.—(Communication.)
2371. John Farrell, Stangate, Surrey—Improved means of insulating wire.
2372. Hon. Frederick W. Cadogan, Hertford-street, May-fair—Improvements in the means of obtaining telegraphic communications applicable to armies in the field.
2373. Auguste E. L. Belford, 16 Castle-street, Holborn—Improvements in drying grain, flour, timber, fruit, vegetables, and other substances.—(Communication.)
- Recorded October 15.*
2374. Richard Gill, Culcheth, near Leigh, Lancaster—Improvements in weaving single and double fabrics.
2375. Charles Coates, Sunnyside, near Rawtenstall, Lancaster—Improvements in, and applicable to, looms for weaving.
2376. Frederick S. Thomas, 17 Cornhill—Improvements in the construction of railway carriages.
2377. Benjamin Price, Fieldgate-street, Whitechapel—Certain improvements in the means of, or apparatus for, reducing the quantity of smoke from the furnaces of boilers, corners, pans, and other like vessels.
2378. John H. Johnson, 47 Lincoln's-inn-fields, and Glasgow—Improvements in the manufacture of iron.—(Communication.)
2379. Buckley Koyle and William M. Chell, Manchester—A certain method of treating silk waste arising from winding, warping, and weaving silk, and rendering it capable of being spun or otherwise employed.
2382. Thomas Woodcock, Barnsbury-road—Improved means of cutting, carving, engraving, piercing, or embossing metallic or other surfaces.
2383. John Peary, Salisbury-crescent—Improved means of preventing accidents on railways.
2384. Alexander M'Dongall, Manchester—Improvements in the process of obtaining fatty matters from products arising in the manufacture of glue and other gelatinous substances.
2386. George Laurie, New York, U.S.—Improvements in the manufacture of artificial teeth and gums.—(Communication from John Allen, Cincinnati.)
2387. Augustus Applegath, Dartford—Improvements in printing and embossing paper, with a view to prevent forgery.
- Recorded October 17.*
2388. George F. Chantrell, Liverpool—Improved apparatus applicable to the manufacturing and revivification of animal or vegetable charcoal, and other useful purposes.
2390. John M. Dunlop, Manchester—Improvements in machinery or apparatus for pressing goods, applicable also to raising or removing bodies.
2391. William S. Low and John Barnes, Rawtenstall, Lancaster—An improved shuttle to be used in looms for weaving.
2392. Capper Pass, Edminster, Somerset—Improvements in the manufacture and refining of copper.
2393. Ellen Jones, Palace-street, Picnicco—Improvements in steam-engine governors.—(This is the same invention as that for which letters patent were granted to her late husband, on the 14th April last.)
2394. Samuel C. Lister, Bradford—Improvements in combing cotton and wool.
2395. John P. de la Fons, Carlton-hill, St. John's Wood—Improvements in apparatus for measuring and indicating the distance travelled by a carriage.
2396. Augustus Applegath, Dartford—Improvements in letter-press printing machinery.
2397. John J. Haite and William Leach, New Coventry-street—Improvements in the pistons of certain valved instruments.—(Communication.)
- Recorded October 18.*
2398. George Price, Wolverhampton—A new or improved method of communicating between the guard and driver of a railway train.
2399. George L. Stocks, Limehouse Hole, Poplar—Improvements in ships' jackstays for masts and gaffs for fore and aft sails.
2400. Charles P. D'Azene, 35 Essex-street, Strand—Improvements in the method of rendering sea water fit for drinking, and all purposes where fresh water is ordinarily used.
2401. Alphonse D. Noel, Chancery-lane—Improvements in the manufacture of zinc white.—(Communication from Louis P. Goslin.)
2402. John H. Johnson, 47 Lincoln's-inn-fields, and Glasgow—Improvements in raising or supporting heavy bodies, for the better preservation of life and property.—(Communication from Yelland Foreman, U.S.)
2403. Cornelius Nicholson, 3 New Broad-street—An apparatus for avoiding collisions of trains on railways.
2405. Isaac Hartas, Wreton Hall, Yorkshire—Improvements in machinery for cutting turnips and other roots.

Recorded October 19.

2408. John W. Child, Halifax, and Robert Wilson, Low Moor Iron Works, York—Improvements in regulating motive power engines.
2409. John Norton, Cork—Improvements in fire-arms.
2410. William Roy, sen., Cross Arthurle, Renfrewshire—Improvements in printing textile fabrics and other surfaces.
2411. Robert Shaw, Glasgow—Improvements in writing instruments.
2412. George Collier, Halifax—Improvements in the manufacture of carpets and other fabrics.
2413. William Little, Strand—Improvements in typographic printing.
2414. Charles Barraclough, Halifax—Improvements in the manufacture of carpets and other fabrics.
2415. James Barton, Robert-street, Hampstead-road—Improvements in fittings for stables.
2416. William Watt, Glasgow—Improvements in the preparation of flax and other fibrous substances.
2417. Thomas Thompson, Much Park-street, Coventry—Improvements in machinery for weaving carpets, coach silk, and velvet.
2418. Alexis Dussac, 33 Grove-place, Brompton—An improved machine for digging and cultivating land.
2419. William Binns, Leeds—An improvement in the treatment or finishing of woollen and worsted fabrics.

Recorded October 20.

2421. William Russell, Birmingham—An improvement or improvements in the manufacture of copper tubes.
2423. John France, North Wharf-road, Paddington—An improved morticing machine.
2424. John B. Burney, Battersea—Improvements in the prevention of smoke in steam-boilers.
2425. Gustave Gongras, Paris—Improvements in huffer traction or suspension springs for railway carriages, trucks, tenders, or locomotives.
2426. Julius A. Roth, Philadelphia, U. S.—Improvements in the bleaching and drying of fibres or fibrous materials, part of which improvements is applicable to the drying of woven and other textile manufactures.
2427. William Melville, Burntisland, Fife—Improvements in apparatus for drawing ships out of water.—(Communication.)

Recorded October 21.

2429. John H. Johnson, 47 Lincoln's-inn-fields, and Glasgow—Improvements in apparatus for sustaining hodies in the water.—(Communication.)
2430. John H. Johnson, 47 Lincoln's-inn-fields, and Glasgow—Improvements in the treatment or manufacture of gutta percha, and in the applications thereof.—(Communication from Jacques Lefevre, Paris.)
2431. Christopher Cross, Farnworth, Lancaster, and James Crosby, Manchester—Improvements in machinery or apparatus for weaving.
2433. James Warburton, Addingham, Yorkshire—Improvements in preparing rape-seed oil.—(Communication.)
2435. Jean F. F. Challeton, Paris, and 16 Castle-street, Holborn—Certain improvements in carbonizing and distilling peat, coal, wood, and other animal, vegetable, and mineral substances.
2436. Pierre M. Fonque, Louis R. Hébert, and Vincent E. D. le Marneur, Paris, and 16 Castle-street, Holborn—Invention of a fortune-rudder, in bronze.
2437. Samuel Lloyd, jr., Wednesbury, Stafford—Improvements in the construction of turntables.
2438. James Greenbank and Samuel Pilkington, Withnell, Lancaster—Improvements in machinery for spinning cotton and other fibrous substances.
2439. Henry Cook, Devonshire-terrace, and Augustus Cook, Upper Berkeley-street—Improvements in the means of communication between guards, engine-drivers, or passengers in or on railway trains.

Recorded October 22.

2441. Harry Bentley, Salford—Improvements in steam-boilers, and in the method of setting or fixing the same.
2442. John Baily, 119 Mount-street, Grosvenor-square—Invention for the cure of the roup and other diseases in fowls and poultry.
2443. Jean F. Mermet, 23 Red Lion-street, Holborn—An elastic spring, contained in a cylindrical tube or tubular case, the lid of which moves down and up according to the pressure.
2444. Thomas Connell, Cork—An improved safety apparatus, and method or means of signalling, to be used on railways in cases of danger or emergency.
2445. Thomas Walker, Pimlico—An improved railway break.
2446. Hume Greenfield, Old Cavendish-street—Improvements in obtaining power by carbonic acid gas.—(Communication.)
2447. John H. Johnson, 47 Lincoln's-inn-fields, and Glasgow—Improvements in mills for grinding.—(Communication from Messrs. Fromont and Son, Chartres, France.)

Recorded October 24.

2448. Henry Kraut, Zurich, Switzerland—Improvements in apparatus for regulating the temperature of stoves and furnaces, and of water, air, or other fluids, contained in vessels or chambers, the strength of spirituous liquors and of chemical mixtures, and the hygrometric state of the air in buildings, rooms, &c.
2449. Thomas Stainton, South Shields—Improvements in steering apparatus.
2450. James D. Young, Westminster—Improvements in casting.
2451. Charles Brewster, Dunmow, Essex—Improvements in printing machinery.—(Communication.)
2453. Alexander Hett, Stoke Newington—Certain improved means or arrangements for the prevention of smoke and the economizing of fuel in furnaces.

Recorded October 25.

2455. Thomas Summerfield, Birmingham—Improvements in the construction and manufacture of windows.
2457. Jean B. Verdan, Paris, and 4 South-street, Finsbury—Improvements in the construction of globes.
2458. John Fordred, Dover, Kent, and Thomas Boyle, Forest Gate, Essex—Improvements in daylight reflectors, and in apparatus to be used in connection therewith.
2459. John D. Brady, Cambridge-terrace, Hyde-park—Invention of an appendage to knapsacks.
2460. Alfred Curtis, Sarratt Mills, Herts, and Bryan Donkin, jr., Bermondsey, Surrey—Improvements in machinery for cutting rags, rope, fibrous, and other substances.
2461. Joseph Beasley, junior, Smethwick—Improvements in the construction and arrangement of puddling furnaces, which improvements are also applicable to other furnaces used in the generation of steam.
2463. Alfred V. Newton, Chancery-lane—An improved construction of printing press.—(Communication.)
2464. David Borge, Fleet-street—Improved mode of producing printing surfaces.—(Communication.)
2465. William Bottomley, North Berley—Improved machinery for hand and power loom weaving, and especially applicable to weaving figured fancy and checked goods, with any number of picks, by Jacquard engines.

2466. Charles Goodyear, Avenue-road, St. John's Wood—Improvements in the manufacture of boots and shoes.
2467. Weston Grimshaw, Mossley, Antrim—Improvements in steam hoilers.

Recorded October 26.

2469. Edward Austin, Pembroke Cottages, Caledonian-road—Improvements in surveying and raising sunken vessels, and in apparatus used therein, and in lifting vessels over bars and other obstructions.
2470. George G. Woodward, Lesswells, near Kidderminster—Improvements in the manufacture of carpets.
2471. Richard Heyworth, Crosshall, near Chorley, and Thomas Battersby, same place—Certain improvements in looms for weaving.
2472. George H. Palmer, Sheffield—Improvements in the construction of air-furnaces for the fusion of steel and other metals, and for economising fuel.
2473. Edward J. Hughes, Manchester—Improvements in machinery or apparatus for sewing or stitching.
2474. William Penrose, Landore Silver Works, near Swansea—Improvements in the reduction of silver ores by mixture with other materials.
2475. Downes Edwards, Douglas, Isle of Man—Improvements in signal apparatus for railways.
2476. Patrick B. O'Neil, 39 Rue Miromenil, Paris—Improvements in screw wrenches.—(Communication.)
2477. Frederick L. H. Danehell, Elm-grove-villas, Acton-green, and William Startin, Heathfield-terrace, Turnham-green—Improvements in obtaining and applying motive power.
2478. Ulrich Lsne, North-street, Brighton—Improvements in measuring and indicating time.
2479. Romain Jolly, Gaillon, France—Improvements in dyeing.
2480. Thomas Duni, Windsor Bridge Iron Works, Pendleton, near Manchester, and William Gough, 21 Old Compton-street, Soho—Improvements in the manufacture of veneers, and in machinery and apparatus connected therewith.
2481. James T. G. Vizetelly, Peterborough-court—Improvements in producing plates for printing purposes, by which the manipulatory process of engraving is superseded.—(Partly communicated.)

Recorded October 27.

2482. Amédée F. Rémond, Birmingham—Improvements in the manufacture of certain kinds of metallic vessels.
2483. Thomas S. Blackwell, Cranbrook—Improvements in apparatus for signaling and stopping railway trains.
2484. Richard Richards, Paddington—Improvements in apparatus for indicating water in the holds of vessels.
2485. Thomas Dawson, King's Arms-yard—An improved case or cover for umbrellas, which can also be worn as a garment.
2487. William Vaughan, Stockport, John Scattergood, Heaton Norris, and Charles Grimshaw, Brinnington—Certain improvements in heads or harness for weaving, and in the method of, and machinery or apparatus for, fabricating the same.
2488. Robert Bishop, Edinburgh—Improvements in steam and water valves.
2489. Henry Dolby, 56 Regent-street—Improvements in embossing presses.
2491. Jean M. A. B. Lemonier, Quai St. Leonard, Liege, Belgium—Invention of a new system of weaving by hand.
2492. Edward Loysel, Paris—An improved coffee-pot.
2493. Joseph Gurney, St. James's-street—An improved mode of treating waterproof fabrics.
2494. Richard A. Brooman, 166 Fleet-street—Improvements in the manufacture of coloured and ornamented fabrics.—(Communication.)

Recorded October 28.

2495. Malcolm Maclaren, Johnstone—Improvements in fire-places, grates, or furnaces.
2496. Aristide M. Servan, 8 Philpot-lane—Improvements in treating phormium tenax, flax, and other vegetable fibrous matters.
2497. John Johnson, Over Darwin—Improvements in looms for weaving terry and other similar fabrics.
2498. John W. Wilkins, Ludgate-hill—Improvements in obtaining power by electromagnetism.

Recorded October 29.

2500. James Nasmyth, Patricroft—Improvements in the pistons and piston-rods of steam hammers and pile drivers, and in the parts in immediate connection therewith.
2501. Edwin D. Smith, 7 Hertford-street, May-fair—An improvement in the construction of railway carriages, whereby, in the event of collision, the crushing of the carriages will be prevented.
2502. Peter O. Bernard, Rood-lane—An improved case or hamper for carrying wine, spirits, and other liquids in bottle.
2503. Richard A. Brooman, 166 Fleet-street—Improvements in machinery for dressing flax, hemp, and other like fibrous substances.—(Communication.)
2504. George J. Gladstone, 10 Brunswick-terrace, Blackwall—Improvements in apparatus for ascertaining and indicating the depth of water in the hold of a ship or vessel.
2505. Andrew Maclure, Walbrook—Improvements in lithographic printing presses.
2506. William Betts, 1 Wharf-road, City-road—Certain improvements in machinery for manufacturing metallic capsules.

Recorded October 31.

2507. John T. Wright, Edwin P. Wright, and William Ashury, Birmingham—An improvement or improvements in mill-handing.
2508. Joseph Haley, Manchester—Improvements in machinery or apparatus for cutting, boring, and shaping metals and other substances.
2509. Edward G. Banner, Cranhamhall—Improvements in obtaining and applying motive power.
2510. Christian Gøethel and Charles M. Zimmerman, Philadelphia—Improvements in stereoscopes.
2511. Felix P. Kovère, 4 Wellington-street, Strand—Improvements in joints for tubular drains.
2512. Percival M. Parsons, Duke-street, Adelphi—Certain improvements in the switches and crossings of railways.
2513. John Gray, Dublin—Invention of a self-acting flushing apparatus applicable to sanitary purposes.
2514. George Hamilton, Paisley—Improvements in spreading or distributing starch, gum, and other semifluid matters.
2515. Anthony P. Coughrough, Blanefield, Stirling—Improvements in printing textile fabrics and other surfaces.
2516. John Brown, Darlington—Improvements in the construction of waggons.
2517. Damiano Assanti, Upper Berkeley-street—A new or improved cooling and freezing mixture.
2518. Richard Restell, Croydon—Improvements in warming conservatories, greenhouses, and other buildings.
2519. Celestin Pechoin and Eugène P. Barades, La Chapelle, St. Denis, France—Improvements in utilizing the saponaceous matters contained in the waste waters of woollen and other manufactories.

Recorded November 1.

2521. John Crowley, Sheffield—Improvements in the construction of ovens and furnaces.
 2522. Samuel Lomas, Manchester—Improvements in machinery for spinning and doubling silk.
 2523. James Hansor, Wandsworth-road—Improvements in the manufacture of illuminating gas.
 2524. Mark Newton, Tottenham—Certain improvements in the construction of carriages, and in the means of preventing the overturning of the same when horses take fright.—(Communication.)
 2525. Arthur Elliott, West Houghton, Lancaster—Improvements in looms for weaving.
 2526. John Whitehead and Thomas Whitehead, Leeds—Certain improvements in cutting-tools, and in the working of iron, brass, and other metals, and wood, and other materials.
 2527. Henry Taylor, Queen-street—An improved chair headstead.
 2528. James Chesterman, Sheffield—Improvements in hardening and tempering steel, and in grinding, glazing, buffing, and crushing steel and other metallic articles.
 2529. William R. Palmer, New York, U. S.—Improvements in the construction of spike thrashing-machines, whereby all liability to, and danger of, accident in their use is removed and prevented.
 2530. Joseph Bauer, Captain to his Majesty the Emperor of Austria's 57th Regiment of Foot, a native of Vienna, in Austria, presently in garrison at Prague, in Bohemia—Invention for cultivating and digging the soil by means of a steam-digging and harrowing machine.
 2531. James Heywood, Ratcliffe Bridge, Lancaster—Certain improvements in machinery or apparatus for printing yarns.
 2533. Robert Archbutt, King's-road, Chelsea—Improvements in wood-cutting machinery.

Recorded November 2.

2534. William Taylor, Newport Pagnel—Invention for stopping of bottles containing aerated liquids.
 2535. Frederick A. Gatty, Accrington, Lancaster—An improved bath for heating and distilling.
 2536. Edwin D. Smith, 7 Hertford-street, May-fair—Invention of a new huffer-break for railway carriages.
 2537. William A. Gilhe, 4 South-street, Finsbury—An improved apparatus for levelling.—(Communication.)
 2538. Edward Ward, Potton—An improvement in carriage axles.—(Communication.)
 2539. William Malthy, Camberwell—An improved system or arrangement for preventing collisions or accidents on railways.
 2540. Brand Willis and John Musto, Mile-End—Improvements in rotatory pumps.
 2541. Frederick Lipscomb, 233 Strand—Improvements in obtaining steam power, and in regulating the same.
 2543. Henry Brierly, Chorley, Lancaster—Improvements in machinery or apparatus for spinning and doubling cotton and other fibrous substances.
 2544. James Howard, Bedford—Improvements in horse-rakes and harrows.
 2545. Richard E. Hodges, Southampton-row, Russell-square—An improvement in fastening the ends of springs made of india-rubber.
 2546. Charles Iles, Birmingham—Improvements in metal bedsteads.

Recorded November 3.

2547. Peter McGregor, Manchester—Improvements in machinery for spinning and doubling.
 2548. William Wood, 126 Chancery-lane—Invention for abstracting and condensing smoke arising from steam-engines and other furnaces, and obtaining a supply of air for supporting the combustion of the fuel in such furnaces, thereby superseding the necessity of chimney shafts and funnels.
 2549. John Moffat, Birmingham—An improvement or improvements in candlesticks.—(Partly a communication.)
 2550. Charles Reeves, jun., Birmingham—An improvement or improvements in the manufacture of swords, bayonets, and sword bayonets.
 2551. Thomas Irving, Dalton, Yorkshire—Improvements in preparing wool for spinning.
 2552. Bryan E. Duppa, Malmaynes Hall, Keut—Improvements in colouring photographic pictures.
 2553. William Patterson, Edinburgh—Improvements in chairs.
 2555. George Duncan, John Boyd, and John Barker, Liverpool—Improvements in casks, and in machinery or apparatus for the manufacture of casks.
 2556. Ebenezer Goddard, Ipswich—Improvements in gas-burners.
 2557. Joseph H. Tuck, Pall-mall—Improved machinery for obtaining and applying motive power, and for raising and forcing fluids.

Recorded November 4.

2559. George Nasmyth, 3 Brahan-court, Philpot-lane—Improvements in the construction of steam-boiler and other furnaces.
 2560. William Hindman, Manchester—Improvements in the construction of steam-boilers, and in the mode or method of fixing the same.
 2561. William G. Ginty, Manchester—Improvements in the mode of manufacturing the combustible gases resulting from the decomposition of water or steam, and in the construction of apparatus connected therewith.
 2562. William Crosland, Hulme, Lancaster—Improvements in apparatus for governing the speed of steam and other motive power engines.
 2563. William Rackster, Woolwich—Improvements in the construction and arrangement of the buffing apparatus of railway carriages, and in the mode of applying the buffer and draw-springs to such carriages.
 2564. William E. Newton, 66 Chancery-lane—Improved machinery for crushing ores, and separating therefrom gold, silver, or other metals contained therein.—(Communication.)
 2565. John H. Higginbottom, Ashby-de-la-Zouch, Leicester—Improvements in water-closets, and in the apparatus connected therewith.
 2566. Henry Pratt, Boughton-street, Worcester—Improvements in kneading dough, and which aaid improvements are also applicable to the kneading or heating of clay, loam, or other plastic materials.
 2567. William Foster, Lister-place, Bradford—Improvements in looms for weaving.
 2568. John H. Johnson, 47 Lincoln's-inn-fields, and Glasgow—Improvements in the manufacture of malleable iron, which improvements are also applicable to the manufacture of other malleable metals.—(Communication from Clement Desormes, Lyons.)

Recorded November 5.

2569. John Smith, Ablon Works, Bradford—Improvements in millstones for grinding corn, seeds, or minerals.
 2571. Samuel Harrison, Crewe, Chester—Improvements in and applicable to steam-engines.
 2572. John Hyde, Sheffield—Improvements in furniture castors.
 2573. Charles Carr and William K. Horsley, Sedghill, Northumberland—Improvements in steam machinery and pumps for lifting water from mines and other places.
 2574. Robert W. Jearrad, 17 Upper Eccleston-place—Improvements in steam-boiler and other furnaces.
 2575. John Rubery, Birmingham—Improvements in the manufacture of open caps for sticks of umbrellas and parasols.
 2577. William B. Johnson, Manchester—Improvements in steam-engines, and in apparatus for indicating the pressure of steam.
 2578. Edwin Kesterton, Long-acre—Improvements in springs for carriages.

Recorded November 7.

2579. Henry Pershore and Timothy Morria, Birmingham—An improvement or improvements in the deposition of metals and metallic alloys.
 2580. John Todd, Fish-street-hill—Improvements in the spindles and bearings of lathes and drilling machines, and in other spindles and bearings.
 2581. Marino L. J. C. V. Falconi, 4 South-street, Finsbury, and Paris—Invention of a certain composition for the preservation of the dead.
 2583. Jonathan Grindrod and Alexander Hunter, Liverpool—Improvements in steam-engines.
 2584. Henry Wiglesworth, Newbury, Berks—Improvements in connecting together or coupling railway carriages.
 2585. Robert Roughton, Woolwich—An improvement in steam-boilers, which is applicable to other vessels, for containing compressed air, vapour, or gas.
 2586. Thomas Walker, Birmingham—Improvements in signal apparatus for the prevention of accidents on railways.
 2587. Alfred V. Newton, 66 Chancery-lane—Certain improved means for preventing the fraudulent abstraction of property.—(Communication.)

Recorded November 8.

2588. John Onions and Samuel Broadhead, Marlborough Estate, Peckham—Certain improvements in machinery used in the manufacture of paper and papier maché.
 2589. John Gardiner and William W. Wynne, Great Marlow, Buckingham—An improved construction of gas stove.
 2590. Edmond H. Graham, Maine, U. S.—Improvements in fire-arms.
 2591. Humphrey Chamberlain, Kempsey, near Worcester—Improvements in the manufacture of bricks and tubes or tiles.
 2592. George F. Parratt, 27 Victoria-street, Pimlico—Improvement in life-rafts.
 2593. Edward L. Hayward, 196 Blackfriars-road—Improvements in the roses of door and other locks.
 2594. John H. Johnson, 47 Lincoln's-inn-fields, and Glasgow—Improvements in machinery for combing and preparing wool and other fibrous materials.—(Communication from Henri J. A. Paris, Paris.)

Recorded November 9.

2596. Benjamin Dangerfield and Benjamin Dangerfield, jun., West Bromwich, Stafford—Improvements in the construction of steam-boilers.
 2597. Thomas Dunn and Joseph Dunn, Pendleton, Lancaster, and James Bowman, Plaistow, Essex—Improvements in machinery for raising, moving, and lowering heavy bodies.
 2598. Jerome A. Drien, Patricroft, Lancaster—Improvements in machinery for cutting velvetene and certain other fabrics, to produce a piled surface.
 2599. John Brown, Darlington—Improvements in coke ovens.
 2600. William Dicka, Floore, Northampton—Improvements in wheels for carriages.

Information as to any of these applications, and their progress, may be had on application to the Editor of this Journal.

DESIGNS FOR ARTICLES OF UTILITY.

Registered from 17th Oct., 1853, to 9th Nov., 1853.

- | | | |
|------------|------|---|
| Oct. 17th, | 3520 | W. James, Bishopsgate-street,—“Rolling-bar for making nails.” |
| 24th, | 3521 | J. Bennett, Cheapside,—“Locomotive regulator.” |
| 26th, | 3522 | S. Green, Lamheth,—“Closet-pan.” |
| 27th, | 3523 | L. M. Fiolet, Finsbury,—“Siphon pipe.” |
| — | 3524 | H. M. Cumberland, Coleman-street,—“Bracelet page.” |
| — | 3525 | G. Chambers & Co., Cheapside,—“Pocket companion.” |
| 28th, | 3526 | Devey and Dale, Shoe-lane,—“Ball-valve.” |
| 31st, | 3527 | Flaugan & Co., Liverpool,—“Æolian hat.” |
| Nov. 8th, | 3528 | C. Gammon, Bloomsbury,—“Collar-case.” |
| 9th, | 3529 | S. Twist and W. Morris, Birmingham,—“Billiard table.” |

DESIGNS FOR ARTICLES OF UTILITY.

Provisionally Registered from 3d October, 1853, to 5th November, 1853.

- | | | |
|-----------|-----|--|
| Oct. 3d, | 534 | J. J. Bennett, Dover,—“Locomotive.” |
| 6th, | 535 | A. P. Poole, Cannonbury,—“Shirt.” |
| 12th, | 536 | J. E. Boyd, Thames-street,—“Scythe.” |
| 18th, | 537 | J. Franckling, Adle-street,—“Belt-clasp.” |
| 20th, | 538 | C. B. Young, Sutton,—“Slah.” |
| Nov. 1st, | 539 | S. Messenger, Birmingham,—“Connecting-link.” |
| 3d, | 540 | J. Walker, London-bridge,—“Bullet.” |
| — | 541 | J. G. Reynolds, City-road,—“Emigrants' table.” |
| 4th, | 542 | C. Gammon, Bloomsbury,—“Collar-case.” |
| 5th, | 543 | J. Walker, London-bridge,—“Rifle-sight.” |

TO READERS AND CORRESPONDENTS.

MONTGOMERY.—The power to be obtained from such a hydraulic engine, depends entirely upon the actuating power of the stream working it. Mr. Sinclair's engine requires a very considerable head pressure, and we should think that all artificial modes of obtaining such elevations would be inapplicable. The engine, like all other movers, will answer for any kind of work. Its power is, of course, dependent on its size, and the amount of head pressure. The inventor is the proper party to give the several details wanted. Neither Mr. Rourke's nor Mr. McGlashan's machine has appeared in this Journal.

E. P., Rio de Janeiro.—Letters received and forwarded.

CONSTANT READER, Penzance.—We can fully sympathize with our correspondent in this grievance. In small figures, it is extremely difficult to make the letters distinct; and although we do not say it with the view of covering the engraver's defects, we think we may fairly challenge comparison with any existing works of a similar character.

YOUNG'S DENTAL INSTRUMENTS.—In our illustrated notice of these instruments last month, we were in error as to the maker. The credit attached to the mechanical production of the new forceps, belongs to Mr. W. B. Hilliard, of 148 Buchanan Street, Glasgow.

L. H. S.—His views ought to be addressed to the publisher.

L. H. S.—All the inventions to which he refers are quite new, and are of course not yet practically known.

CHARCOAL DUST.—The following is in reply to our note last month. It refers to only one, but a very obvious application:—Ironfounders use large quantities of charcoal, ground very fine. It is worth from £8 to £10 per ton here.—James Willoughby, Central Foundry, Plymouth.

RECEIVED.—“Programme of Astronomical Lectures at the Edinburgh University, 1853-4.”—“Remonstrance against Mr. Bateman's Plan of Supplying Glasgow with Water,” by L. D. B. Gordon, C.E.—“Colt on Revolving Chamber Breached Five Irons.”

THE NEW CRYSTAL PALACE.

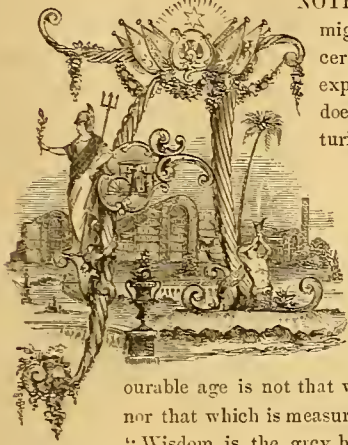

"NOTHER hour — another age." So might we invent a proverb, and all certain history would justify the expression. Thought by thought does progress run along the centuries; and rising higher, or stretching wider, at every step the boundaries of the infinite become more defined, and that which was esteemed but a superstructure becomes an imperishable foundation. Truly and eloquently did the sage of old write and tell us how "Hon-

ourable age is not that which standeth in length of time, nor that which is measured by number of years," but that "Wisdom is the grey hair unto men, and an unspotted

life is old age." It is thus we must reckon as we take stock of the accumulated treasures of the world; and, by reckoning thus, the proverb we have improvised, startles us with its awakening truth.

The hallowed festival which we have just celebrated, reminds us of the most pleasing proof we can adduce. When the jargon of logomachy had severed the unity of the noblest religion upon the earth, and teachers of the divine law were disputing among themselves with the greatest rancour and animosity—when the mass of the intelligent of the congregation were attracted from attention to the affairs of another life, by the incomprehensible controversies which met their ears in the solemn temple of their God—when these disputes and these controversies had lasted a time—another hour, and all became changed—and changed for ever! One came among them whom they knew not; one who sat in their midst, and heard them, and asked them questions. Upon those who listened, another age supervened—not suddenly, it is true, but quietly and certainly. The colour of the time, though perceived darkly and dimly at first, gradually tinted with its glorious hue the succeeding years, until all Europe confessed the faith promulgated at the door of the Holy Sepulchre.

Again, when man had exhausted his many means of exhibiting both his belief and unbelief of the sacred dogmas of his new religion—when the burning thirst for power had well nigh secured the grasp of power, and form again took the place of substance, and ceremonial of the hidden life of the heart—in a lowly home of Saxony, a time-piece was sounding which was destined to visit all the then existing and all future corruption with its own punishment, and to make the desert blossom as the rose. Another hour sounded, and civilized man began to live a new life, in which even the larger portion have not yet advanced to years of discretion; but still it is come, and we in our own beloved country have reason to rejoice daily that it has come.

Again, in other things, less lofty, indeed, but scarcely less interesting to us, as applicable to men's business and labours, if we listen ever so inattentively, we can occasionally hear the great clock of ages striking another hour, ushering in another imperfectly conceived and wonderful age. It was heard thus striking when that young Englishman, trying to apply the visibly wasted powers of nature to "the good of man's estate," in his dull and silent chambers of Gray's Inn, started up from the mystical book he was reading, and, pacing his room with pleasurable perturbation, hunted down the grand new thought that had glanced across his mental vision. Nature herself was nature's storehouse, wherein to find her treasures, and not the false pictures of her as man had drawn them. *This* hour has not done striking yet. It sounds no uncertain chime—it booms forth no unknown tongue. He that can spell, may read it. It forms the manuscript diary of our life—the romance of our

brightest being. It is the mighty missionary, confined in his duties to no place, to no time, crying out, not "Give, give," like the daughters of the horseleech, but persuading all, with a countenance of beauty and a voice of melody and power, to come in and receive of its bounty. Its arguments are visible—tangible. Does not hundred-handed steam proclaim its own mighty worth? Has not the silent electric wire a speech of telling sweetness? Is not the "pencil" of light (happily named!) a kindly master of art? While the results of chemical study are being wrought into the very frame of social happiness. It may be that, as the poet sings—

"There hath passed away
A glory from the earth."

But it is only a change—a change from one glory into many others; and in both, the spirit that is weak and the spirit that is strong, there is a capacity to participate and enjoy—a yearning to collect and to distribute the precious things that physical science has not only given, but to which it also clearly points. It has made art its foster-brother indeed; and, active with all modern and ancient virtues, it is gradually linking the whole human family into one, having the same end, and means in common to attain it. True, it may be that the poet, too earnestly desiring its complete accomplishment, with his eye "in a fine frenzy rolling," may view coming ages in the field of the present time, and, as is his wont, reflect his own serenity upon all the borders of mankind. If, however, nothing better, this must be considered merely as a harmless amusement. He sees the consummation of another mighty revolution in the earth, as the business-man of our times sees the meaner occurrence of a reformation of a municipality or a university. It is, however, beginning to be confessed by all, that great works have been done, are being done, and will be done—the labours of our fathers will be eclipsed by ourselves, and we shall be outran in the race by our own descendants. There is no doubt of this at all. It is unavoidable as ancient Fate—it is uncontrollable as modern Hope.

And is it but an uncertain glimmering of his true relation to these things that is caught by the reflective practical mechanic? He has but to look aside, and demonstrations of moment object themselves to him. He finds that he is not a mere passing observer. In the midst of it all, and analyzing with intuition what he sees before him, he is prided to believe himself to be not merely a part of it only, but the solid foundation of it all likewise.

It is the conviction of this which makes him watch with interest every little onward step, and it is this which compels him to regard, with interest of the highest kind, the first single great public establishment conceived and executed purposely to enlarge the general bounds of human achievement, by showing, in an instructional manner, all that has been accomplished; and thus, ever more and more, suggesting to the working mind things that are to be done. Such an establishment is *The New Crystal Palace*.

We could have wished the name of the institution, likely to become so popular, to have been a little less connected with the brilliant, but ephemeral, display of 1851. We apprehend the new society will lose much every way by this name. It will receive a tinge of perishableness from it, while it will be capable of showing, as in a mask only, most of the pleasing realities that met the eye in Hyde Park. Hence will arise, even in the best wishers of the prosperity of the concern, a sentiment by no means healthy, coupled, at the same time, with a predominant idea of the absence of verisimilitude—a want of truth. However this may be, if the ideas of the promoters be carried out to a measure of fifty per cent. of their published intentions—and they certainly have, as yet, given us every reason to believe that their intentions will be more than realized—a very great work, indeed, will have been commenced before the end of the present year. To-day will the mighty cobweb-dome receive its last survey, previous to the contractors for the building handing it over to the painters and decorators. When these

have accomplished their task, then will the walls and counters begin to receive their varied and valuable stores of natural and artificial productions. Waggon-loads upon waggon-loads must, we know, be exhausted, and pantotechnica emptied, before the vast area, so delicately covered, shall cry "Enough, enough;" and it will be a strange thing, indeed, if the simple and common, as well as the intricate, marvels of mechanism have not a large space devoted to them. We have been informed that the directors, with a wise foresight, have remembered the principal attractions of the Great Exhibition, and have taken these as the cue for their own higher efforts. If this be true, the New Crystal Palace will be more popular in its examples of mechanism, than was its elder sister, constantly crowded as her own little storehouse of such instruments usually was. So instructive a school of mechanical art will never before have existed. This alone will be sufficient to render the immense undertaking worthy in the eyes and hearts of our readers.

But mechanical art is ostensibly to be only one of many departments of art which are to subserve the purposes of this gigantic national society. Notwithstanding this, the practical mechanism of our day will be admirably illustrated—at least, it is the intention of the directors that it should so be. There were many patent defects, in this respect, in the first and last grand assemblage relating to the subject. Matters were not put before the eyes, as imperatively required, in an *educational* form—in such a form that, while they attract, they should teach—in such a form as that, while we are looking at them, we are learning, and learning, not with the pain of forced abstraction, but by the very means of our delight. There are few such methods as yet in practice; but any one who has carefully studied the art of teaching, as he has daily presumed to be the teacher, of children especially, knows how much more easily, as well as satisfactorily, is knowledge communicated in this way. We heartily congratulate our young friends upon the prospect of the opening of this new school for them. And if the directors shall continue to deserve the praise which they are challenging to themselves, we doubt not that the education of the practical mechanic, in no part of the British Isles, will, after a time, be considered complete, until he has passed some months within the New Crystal Palace. We cannot help looking forward to a time when professors in this particular department will be established there, surrounded immediately, as they will be, by a complete museum of mechanical apparatus; where regular lectures shall be delivered, and grades of honour attainable, which shall be coveted as greedily as any honours now within the grasp of the youthful aspirants in our common profession. Such a scheme as this, noble as it would be, cannot be out of the purview of men who are entitled to the highest sympathy and respect for everything they have yet done towards fulfilling their promises within the precincts of the unrivalled building, which has been now made ready for their purposes by the practical mechanic alone.

And so, bidding them farewell for a season, we wish their project a "Happy New Year!"

GILBY'S BREECCH-CHARGING AND SELF-PRIMING RIFLE.

This new arm, which has been patented by the inventor, Mr. J. Gilby, of Beverley, throughout Europe and America, is assumed to possess the following advantages:—

1st. Peculiar facility for rapid charging at the breech, either with flask and ball, or with cartridge.

2d. Superior strength, with accuracy and security in firing.

Fig. 1.

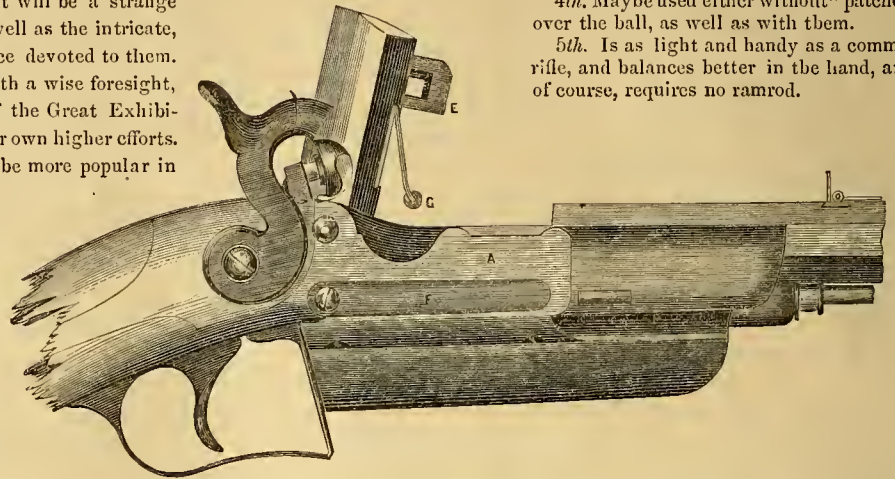

3d. Freedom from fouling, until after very long and rapid shooting.

4th. Maybe used either without "patches" over the ball, as well as with them.

5th. Is as light and handy as a common rifle, and balances better in the hand, and, of course, requires no ramrod.

6th. Being simple, and easily managed, it is equally well adapted for sporting or military purposes.

Fig. 1 of our engravings is a side external elevation of the rifle lock, with portions of the stock and barrel; and fig. 2 is a corresponding longitudinal section of the same parts.

A breech-case, A, occupies a great part of the space usually taken up by the forestock, connecting the stock and barrel as firmly as if these parts were in a single solid piece. The fastening to the barrel is effected by transverse steel bolts, whilst a breech-plate, B, secures it to the stock above and a trigger-plate, C, below. The breech is detached from the barrel, and has a joint at its end, D, the bore of the breech being slightly larger than that of the barrel. At its fore end is a loop, E, having a rounded projection, which works against a spring-catch, F; so that, when the breech is shut down, after charging, the spring-catch enters the loop, and thus holds the breech in security.

Fig. 2.

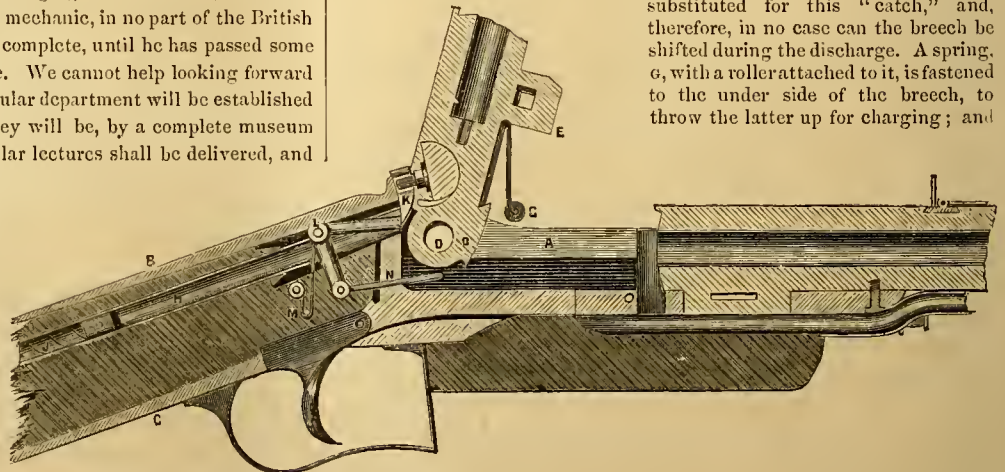

In rifles of large bore, a steel bolt, passing through the loop, and completely across the breech-case, is substituted for this "catch," and, therefore, in no case can the breech be shifted during the discharge. A spring, G, with a roller attached to it, is fastened to the under side of the breech, to throw the latter up for charging; and

it is readily liberated, when required, by a stud and pin on the left side of the breech-case, working against the catch or bolt, and moved by the left hand, as the rifle is held in the usual manner.

The ends of the barrel and breech are cut at similar angles, so that the fitting surfaces are brought into direct and actual contact round the entire circumference of the bore. The gaseous escape during discharge is very slight; but, to carry it off, a groove is cut in the inner circumference of the breech-case, round the junction of the barrel and breech, and an aperture is left in the bottom of the breech-case, opening into an escape tube, fastened along its under side. By this means, the "foul-

ing," so often complained of in breech-charging guns, is effectually prevented.

The lock is situated on the left side of the rifle, and the tumbler-pin is brought through the stock, so that the hammer occupies its usual position. This leaves room for the priming apparatus, which fills the space commonly assigned to the lock. But when no primer is required, the breech-charging principle alone being applied in the piece, the lock obviously occupies its usual position.

At *u*, in the stock, is a metal tube, of a bore sufficiently large to admit the caps, running along it end to end, with a spiral spring, *j*, inside, to force them forward as required. This tube is inserted at the butt end of the stock, and is continued far enough to reach up to the detent, *x*, which moves on a pin at *z*, and is forced up by the spring, *m*. At *n* is a small connecting-rod, passing through the breech-case, and acted on by a shoulder or projection on the joint of the breech at *o*, when the breech is shut down, forcing the detent down at the same time. A hole in the part of the detent, just opposite the end of the tube, *u*, now receives a cap, forced into it by the spiral spring in the tube. Thus the store of caps is closed against the influence of the weather; and in this position they remain until they are brought up, one by one, by the action of the priming apparatus; and the nipple is projected into them as they arrive, by the upward motion of the breech, so that the latter is primed by its own movement. After charging, the breech is again shut down in its place, carrying with it the cap just put on. The primer is more especially adapted for rifles of a bore above 40, but it is capable of use in smaller pieces.

THE LAW OF PATENTS FOR INVENTIONS IN RUSSIA.

The law as to privileges for inventions in Russia was declared by an imperial decree of the 17th of June, 1812.

The privilege granted for inventions in arts and manufactures is founded upon a certificate (obtained on presenting a petition to the Government, accompanied by a full description of the invention), which certificate will state that the invention therein mentioned was presented in due time to the Government, as the property of the person named therein.

The Government does not guarantee that the invention belongs to the person who makes the application; it only certifies what are the peculiar properties of the invention when it is presented.

The privilege granted by the Government does not prevent other persons from proving, in legal form, that the invention therein mentioned does not belong to the person who presented it.

Until the ownership of the invention is contested, the person to whom the privilege was granted has a right—

1. To the absolute property in the invention for the specified time.
2. To use the invention himself, and to sell its results to the public, or to transfer the privilege to another person.
3. To prosecute persons infringing the privilege in the courts of law, and to recover an indemnity for the loss sustained by the infringement.
4. To treat as an infringement the making of articles in a similar manner with small and unessential differences.

The person applying for a patent privilege shall deliver to the Government an exact description of his invention, with all essential details, and the mode of carrying it into effect; and also, the necessary plans and drawings, not keeping back anything requisite to be known.

No patent privilege will be granted when such an exact and detailed description shall not have been delivered.

No patent privilege will be granted for inventions which are likely to injure, or not to benefit, the state or individuals.

Inventions made in foreign countries may be patented in Russia when no detailed description has been published, and when they have not been already introduced into the empire.

A patent for an imported invention will have the same validity as one granted for an invention made in Russia, until it is shown that the invention had been brought into use before the grant, or that it had been described in published books or papers, in such a way that it could have been carried into effect without the patentee's description.

Patent privileges for original inventions are granted for three, five, or ten years (the extreme limit), at the option of the applicant; for imported inventions the longest period is six years. The Government charges amount, on patents for original inventions for three years, to 300 rubles (£15), for five years to 500 rubles (£25), and for ten years to 1,500 rubles (£75); whilst, in the case of imported inventions, the Government charges, in respect of a four years' patent, are 800 rubles, in respect of a five years' patent, 1,000 rubles, and in respect of a six years' patent, 1,200 rubles.

A patent will be void when it is shown to the proper tribunal that the invention has been already practised in Russia, or that, at the time of the presentation of a petition for a patent, it had been previously described in books or periodicals published in Russia or elsewhere, so that it might have been carried into effect without further description. It will also be void where it is impossible to arrive at the promised result by following the directions of the patentee.

In case of the absence of the inventor, the person applying for the patent must be duly authorized by power of attorney, and this person will have to give a written engagement for payment of the money due to Government.

No prolongation of the term originally granted can be obtained. For improvements in a patented invention, a new patent must be applied for. A patent for an imported invention expires at the same time as the patent in the country from which the invention was brought. An invention for which a patent has been obtained, must be carried into effect within one quarter of the space of time for which the patent was granted.

SIEMENS' IMPROVED CHRONOMETRIC GOVERNOR.

The ordinary rotatory pendulum, or Watt's centrifugal governor, is a very imperfect regulator of the steam-engine's action. In fact, it does not regulate, but rather moderates the velocity; for it cannot prevent a permanent change in the engine's rate, when a permanent change occurs in the load; and it can only moderate the permanent change in velocity, because its influence upon the throttle-valve is essentially dependent upon a change in the angular position of the pendulums, which change

Fig. 1.

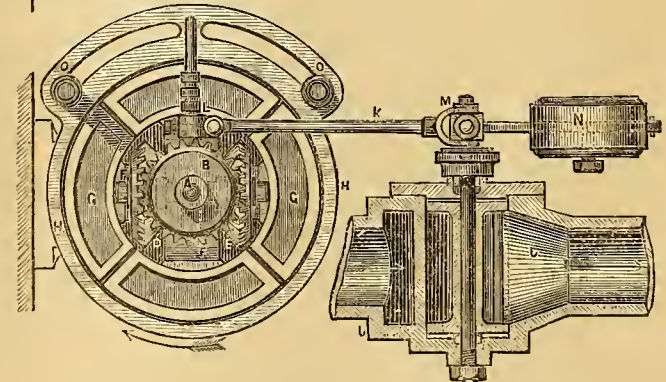
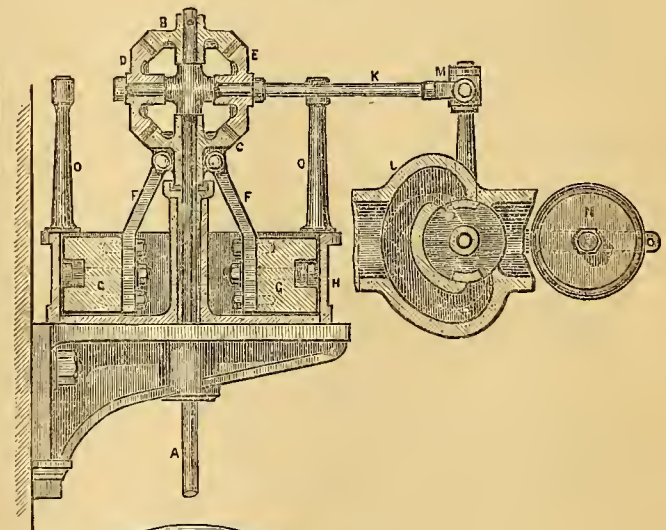

Fig. 2.

is produced only by permanent increase or decrease in the engine's rate.

Another defect is, that it cannot begin to act upon the regulating valve, until after the engine's rate has undergone a material variation;

for, at the instant of the removal of a part of the driven load, the pendulums are still in equilibrium, and it is only by aggravation of the evil that they acquire power enough to overcome the valve's friction. Then, in checking the effect of this loss of time before the governor really acts, the valve is moved too far in the opposite direction, and hence arise endless fluctuations in the velocity.

The most notable of the attempts at a remedy for these defects, is the "chronometric governor" of Messrs. C. W. and W. Siemens, who have applied their ingenious arrangement to a great many engines since 1845. This contrivance is composed of two essential parts—the chronometer and the differential movement forming the connecting link between the chronometer and the engine, and being the part producing the necessary effect upon the steam-valve. The chronometer is required to possess these properties:—

1st. To measure the time by a continuity of motion, in contradistinction to the vibrating pendulum, which deals it out in units.

2d. Possession of sufficient momentum, or instantaneous power, for overcoming resistance and acting upon the valve.

3d. The allowance of great fluctuations in its maintaining power, without suffering its speed to alter.

4th. The derivation of its maintaining power from the engine, whilst it is yet affected uniformly by the engine, just as a domestic clock derives its maintaining power from a falling weight.

The delicacy of the details, and the expense of constructing the chronometric governor, as originally designed, have hitherto impeded its general introduction as a regulator; and the inventors have, therefore, modified the apparatus to the form shown in figs. 1 and 2 of our annexed engravings.

Fig. 1 is a sectional elevation of the improved governor; and fig. 2 is a plan, with the valve alone in section. The connection with the engine is by means of the vertical spindle, *A*, which may be supposed to represent the ordinary main centre spindle of the common governor. It works up through an eye in the bearing bracket for the chronometric arrangement, and has upon its upper end a pair of opposed or reversed bevil-wheels, *B*, *C*, forming a differential quadruple wheel combination with the other two wheels, *D*, *E*. The last two wheels are entered upon the two ends of a short spindle, through an eye, in the centre of which the spindle, *A*, is passed. The bottom wheel, *C*, of the set, has a set of four eyes upon its lower side, forming stud joints for four links, *F*, which are attached to the inner sides of the four segmental iron blocks, *G*, contained in the interior of the friction case, *H*. The connection of the differential movement with the regulating valve, *J*, is through the link-rod, *K*, one end of which is jointed to a crank lever standing out at *L*, from the cross spindle of the two wheels, *D*, *E*, the other end being jointed at *M*, to the valve lever. The valve spindle also carries a weighted lever, *N*. The upper wheel, *B*, is fast on the spindle, *A*, going at 62 revolutions per minute, the opposite wheel, *C*, being loose on the same spindle. The other two vertical wheels, *D* and *E*, gearing with the horizontal pair, are also loose on their short cross spindle. Thus, as the engine drives round the spindle, *A*, the wheel, *B*, upon it, drives the two wheels, *D*, *E*, in reverse directions, and these two drive the bottom wheel, *C*.

Those who are acquainted with the old form of chronometric governor will be at no loss to see the important improvements secured in the new one. On the engine being put in motion, the weight, *N*, on the valve spindle lever accelerates the rate of the friction block, or "fly-wheel" arrangement, *G*, until the centrifugal force of the segmental blocks exceeds their gravity, and causes them to traverse outwards. At this instant they come in contact with the interior of the casing, *H*, and as they revolve at a considerable speed, the friction thus generated absorbs the excess of maintaining weight applied. Stops, *O*, are provided for the restraint of the lever, *L*, on each side.

Experiment has shown that this governor will permanently support $1\frac{1}{2}$ cwt. on the throttle-valve lever, and it possesses the important advantage of working well at an angle, so that it is suitable for marine engines. Its great power would also enable it to act upon the lever of an adjustable screw propeller, the pitch of which it would thus be enabled to regulate, so as to maintain the engine at a uniform rate, independent of the vessel's speed. The throttle-valve represented in our figures has its spindle entirely relieved from the steam pressure, the steam being made to enter from opposite sides, as shown by the arrows.

The best illustration of the perfection of this governor's action is given in the fact, that where applied to a fifty-horse engine, sawing 16-inch baulks into sleepers, the work coming and going suddenly with the commencement and finish of each saw-cut, the rate of the engine varied no more than one stroke per minute on 35 strokes, as the regular working rate. This ingenious regulator has now a better chance of getting into every-day use; for there is nothing delicate about it, and its cost is certainly not in the way.

HUTCHINS' LIFE-BOAT.

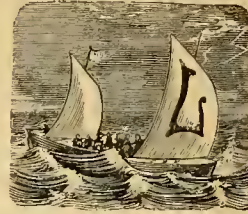

LIFE-BOAT building has latterly been the subject of a vast amount of experimental research; but of all this practical examination, great good must undoubtedly be worked out; for, under the operations of so many separate inquirers, we may surely anticipate that time will bring us effective combinations of many essentially good points, hitherto isolated and useless. The present Exhibition at the Society of Arts has brought together many hints for the purpose, and from these we have selected the boats designed by Mr. W. Hutchins, of Croom's Hill, Greenwich, as illustrative examples of the latest attempts at improvement.

Our fig. 1 represents a ship's boat, of ordinary build, as fitted with the

Fig. 1.

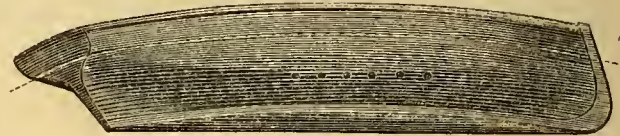

inventor's metal keel, and air-tight floor above the water line, with tubes for shipped seas to pass through. The discharge apertures of these tubes, six in number on one side, are represented in the view before us; and above them is a dotted line, indicating the floor, the boat being well careened over, to show the wide keel. It is calculated that the long-boat of a thousand-ton ship, built on this principle, of gutta percha, would save fifty hands.

Fig. 2 is a plan of the keel alone. For a boat 35 feet long, it would be

Fig. 2.



about 18 inches wide at midships, and running down to the usual width at each end. By this plan of construction, the weight of ballast is well distributed, without necessitating the use of a deep keel, which would endanger the boat's safety in taking a shallow beach in a heavy sea.

Fig. 3 is an internal view of the boat, as lying on the sand, showing

Fig. 3.

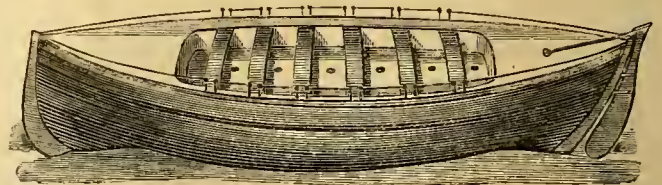

the discharging tubes, which are fitted with valves opening downwards—the air-tight locker on each side—and the bulkheads and air-tight sections at the stem and stern.

Fig. 4 is a transverse section of the boat, in explanation of her air-tight lockers and end, her floor and discharge tubes, keel, and bilges as deep as the keel.

Our initial figure shows the boat under storm canvas, with the mizen well forward, that she may not require an out-rigger for the mizen-sheet. That something must be done in the way of producing boats worthy of the dignity involved in the appellation "life"-boats, is painfully obvious, from the fact that three of the Northumberland Prize boats have capsized under canvas, drowning the chief part of their crews. In these boats, the ballast, which was water confined in a case running inside from stem to stern, evidently afforded insufficient leverage. In the case of the Tenby boat, on turning over under canvas, she would not right until the fore halcyards were let go, and the sail taken in. Besides

Fig. 4.

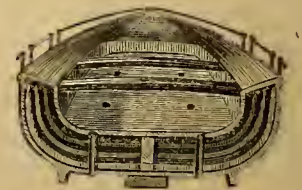

this, the boatmen admit that they cannot pull her against a heavy sea and head wind. A life-boat, to be a reality, ought to be so constructed as to be able to beat to windward under canvas in a gale, without the slightest chance of capsizing; and the deposition of the ballast along the keel, instead of inside, offers a great assistance towards such a result, especially in boats which must not draw too much water. Boats for steamers and large ships, it is asserted by the inventor, might be constructed on this principle, so as to be always ready for use; and, if built of gutta percha, they would run little risk of being damaged by coming in contact with floating wreck, or getting dashed against the ship's side in launching.

BOUCH'S "FORM AND COLOUR" RAILWAY SIGNAL.

The numerous railway accidents which occur, either from "colour blindness" on the part of the engine-drivers and look-out men, or from the general want of distinctive features in the signals themselves, have induced Mr. T. Bouch, C.E., of Edinburgh, to turn his attention to some

Fig. 1 is a front elevation of a signal of the improved kind, as arranged in what may be termed its primary position, presenting a plain white disc to the view of the engine-driver, indicating that the line is clear, and therefore that the train may safely proceed. Fig. 2 is a corresponding side view of the signal at right angles to fig. 1. Fig. 3 is a detached front view of the actual signal portion alone, representing the indicating apparatus in its second position, to show that a passing train must proceed with caution, a square green disc being displayed for this purpose. Fig. 4 is a similar detached view of the disc-signalling details, wherein two distinct red discs are exhibited, to indicate danger.

The signal is constructed in its general details on the same plan as the common apparatus. It consists of a stout wooden pillar, a, carrying horizontal side brackets, b, in which brackets are plain eyes, to receive the parallel vertical iron rod, c. This main post, a, is fitted with a ladder, d, and platform, e, in the usual way, for the ascent of the signalman; and its inner front face carries a stationary circular disc, f, with a red face, pointing in the reverse direction to the train's motion. The long adjusting rod, c, is passed freely through its plain eyes in the brackets, b, having liberty both to rotate and traverse longitudinally therein, a collar being on the lower end of the rod, to prevent it from traversing too high at any time. This rod is surmounted by a circular signal disc, h, coloured white on one side, as shown in fig. 1, and red on the other, as in fig. 4. Beneath this disc, the rod also carries a second disc, i, of a square or rectangular shape, and checked or half-entered into the upper disc, n, forming one piece with it. These details, with the ordinary lamp, j, on the apex of the rod, c, form the entire signalling apparatus. The front face of the timber post, a, has also bolted to it, lower down, a spiral guide-piece, or curved incline, k, beld at its two ends, l, in a fixed position. This spiral piece embraces the rod, c; and an adjustable arm, m, standing out at right angles from the rod, carries a small pulley, n, upon its outer end, bearing upon the edge of the incline as a support, a small handle, o, being fitted up with a catch, as shown in dotted lines, for manual adjustment. Or, when the signal is to be actuated from a distance, by cords or ropes, in the usual way, the common signal wire-rope is passed round a pulley, keyed on near the lower end of the rod, a. An additional lamp, q, may be attached to the red face of the upper disc, h, as a security against danger, arising from colour blindness, or an inability fairly to distinguish different colours. When the signal is in its first position, as delineated in figs. 1, 2, and 3, the circular disc, having its white face towards the approaching train, completely covers or conceals the fixed red disc, f, on the wooden pillar, from view; whilst the green disc, i, being turned with its edge towards the coming train, is also invisible. Under these circumstances, then, the engine-driver, seeing only the white face, or a single round disc, knows that the line is clear for his journey. But if, from any cause, "caution" is to be signalled, the signalman, either by his wire-rope and pulley, or the adjusting handle, o, turns the rod, c, one quarter round upon its axis. Then, as the arm, m, is fast on the rod, c, it goes round with it; and in the traverse of the pulley, n, over the incline, k, the rod, c, is caused to rise up through its bracket bearings, so as to bring the signal discs into their second position, as represented in fig. 3. The circular red and white faced disc is now turned with its edge towards the train, and is therefore invisible; whilst the rectangular green disc, i, faces the train, and covers up or conceals the fixed red disc, f, entirely from the driver's view;

Fig. 1.

Fig. 2.

Fig. 3.

Fig. 4.

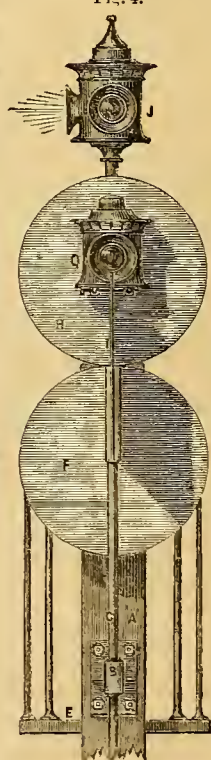
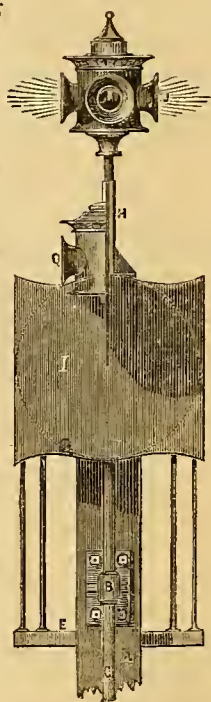
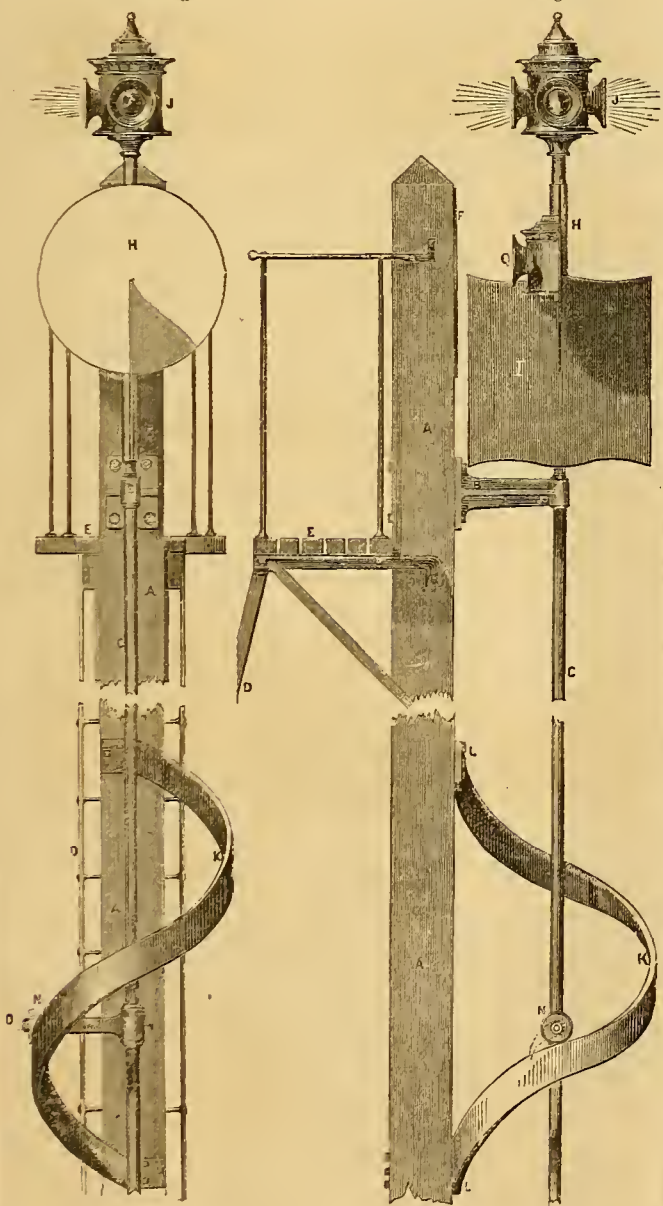

system of signals, which should combine form and colour images, and thus present the clearest possible indications of what is intended on the part of the station-keepers. Our illustrations very clearly show the ingenious contrivances which Mr. Bouch has adopted in working out his plans.

so that, as the look-out on the train sees only the green disc, he at once knows that he must run slowly and with care. If "danger" is to be signalled, for the purpose of stopping the train, the signalman turns the rod, *c*, another quarter round; the resulting traverse of the arm, *m*, over the spiral guide, *k*, carries the rod still further upwards in its bearings, bringing the signal discs into their third position, fig. 4. The circular disc, *n*, having thus been turned a full half round, now presents its red face towards the train; and its increased elevation, due to the spiral guide action, having brought it to a higher level than that of the stationary disc, *r*, the engine-driver now sees two separate red-faced discs of circular shape, forming a very striking "stop" signal. On reversing the action of the rod, *c*, the discs are obviously brought back into their normal position, as in figs. 1, 2, and 3.

For night-work, the lamp-signals will act in this manner:—In the first position, the lamp, *j*, on the top of the rod, *c*, will give a white light, indicating "all clear;" whilst the lower, or secondary lamp, *q*, is screened by the circular disc, *n*. In the second position, when the rod, *c*, is turned one-fourth round, the upper lamp, *j*, has a new branch brought forward to throw out a green light, indicating "caution," the secondary lamp, *q*, being still shaded. In the third position, the third branch of the compound lamp, *j*, will give out a red light, whilst the single secondary lamp, *q*, is now brought to bear, and gives a similar red light, both in the direction of the approaching train. In this case, should the look-out be affected with colour blindness, he will yet be put on his guard by the appearance of two distinct lights, indicating danger.

The superior degree of safety attending the use of these signals must soon lead to their general adoption. They are, indeed, already at work on several lines of railway, under Mr. Bouch's charge.

DEAL SAWING-MACHINE.

By MESSRS. WORSSAM AND CO., KING'S ROAD, CHELSEA.

(Illustrated by Plate 141.)

The deal sawing-machine, delineated in the two views on our Plate 141, embodies all the latest improvements by the makers, and, in particular, a novel feed motion, recently patented by Mr. Archhutt, of Messrs. Worssam's firm. Fig. 1 on our plate is a complete side external elevation of the machine, showing a deal in the act of passing through. Fig. 2 is a corresponding front view, at right angles to fig. 1, with the saws in edge view. The main framing consists of a pair of lower vertical standards, *A*, bolted down to a stone foundation, and carrying two upper standards, *B*, bolted on by intermediate flanges, to form continuous pillars. The whole of the movements are worked from the fast and loose band pulleys, *C*, fast on the projecting end of the horizontal shaft, *D*, carried by an end bearing on the stone foundation, and a second bearing in the base of one of the standards. This shaft, which is fitted with a small fly-wheel, to steady the motion, has on its inner end a crank disc, *E*, from the face-pin of which a connecting-rod, *F*, passes upwards to the saw frame. The end view shows that the machine is duplex, taking in two deals, the working frame being divided down the middle, so that the upper end of the actuating connecting-rod is jointed to the centre of the frame, thus saving height, without interfering with the efficient action of the machine. The slide-pieces, *G*, of the frame, are guided in the stationary eyes, *H*; and on the opposite side of the standards are two parallel spindles, *I*, carrying adjustable lever pressure pulleys, *J*, for bearing up against the timber to the fence in passing through. These spindles are grooved, to allow of the setting up or down of the pulley-holders; and the requisite set-up is accomplished by the hand-wheels, *K*, set on screw spindles, passed through nut levers on the upper ends of the spindles, *I*, spring-boxes, *L*, being fitted to the framing, to secure the necessary elastic action in working. The holding-down pulleys are at *M*, in adjustable eye-pieces above the timber, the bearing pressure being obtained from the weights, *N*, hung to the free ends of a pair of pressure levers, *O*. These levers are suspended from fixed stud centres, *P*, and links, *Q*, pass upwards from them to the pulley holders, sliding in slotted guides above. This pressure keeps the deal well down upon the feed chain, *R*, which is carried at one end upon a stationary pulley, *S*, and at the other upon a similar pulley on the spindle, *T*, of the large ratchet-wheel, *U*. Each sawing action has, of course, a separate chain and pulley arrangement, and both are worked from the eccentric, *V*, on the first motion spindle, *D*; a rod, *W*, from which passes up to a ratchet-lever, *X*, working the ratchet-wheel, *U*. The exterior working edges of the bearing surfaces or edges of the chains, *R*, are serrated, so as to obtain a hold upon the timber; and as the eccentric, *V*, revolves, it actuates the ratchet-wheel, *U*, and through it the chains, *R*, thus feeding the deals steadily up to the cut. This ingenious movement forms a very efficient feed, without involving the use of anything more than the simplest mechanism, and fewest possible working parts.

RENSHAW'S ENGINEER'S SHAPING MACHINE.

(Illustrated by Plate 142.)



SHAPING machines proper are thus named, in contradistinction to ordinary lathes, planers, and drills, which can only accomplish one regular class of operations, whereas the shaper, in virtue of its combination of the powers and movements of all the simple tools, is capable of working out differentially-curved and other complex figures, in addition to its individually simple cutting movements. Machine tools of this class are becoming more or less indispensable in all mechanical engineering establishments of superior pretensions, where work, deemed impossible a few years ago, is now being executed with all the ease and precision which formerly alone attended the simplest constructive processes. To Mr. Renshaw, of Nottingham, much is owing for his recent suggestions in this elevated range of workmanlike contrivance; and our Plate 142 will illustrate how far he has carried the perfection of details into the minutest crevices of his schemes.

This plate represents a side elevation of a composite slotting and shaping machine tool, with self-acting gearing, as adapted for the entire finishing of large cranks, levers, wheels, and other work, ordinarily dependent upon the efforts of several tools. This particular example is more especially intended for slotting and shaping heavy work of considerable length, and serves, besides, as a complete vertical lathe for boring and turning large wheels, the outsides of cylinders, and other articles, as well as the self-acting shaping out of curved surfaces, which cannot be so turned in the common lathe.

The main frame consists of a plain stout column, *A*, cast with a rectangular base for bolting down, along with the rest of the stationary groundwork, upon the base line, *B C*. The upper part of this column has cast upon it upper and lower projecting bracket arms, *N*, to carry the vertical cutting slide, *E*, in dovetail faces, motion being given to the slide, when slotting, by the connecting-rod, *F*, jointed at one end to a stud-bolt in the slide, and at the other to an adjustable stud-pin in the grooved face of the crank disc, *G*, fast on one end of the shaft, *M*. Motion is communicated to the entire machine by the fast and loose pulley movement, *I*, the first motion shaft of which is carried in the pedestal bearings, *J*, and carries a cone pulley, *K*, driving the corresponding cone, *L*, upon the shaft, *M*. By means of a sliding clutch, this cone movement is made to actuate the spur pinion, *X*, at pleasure, thus giving motion to the large spur wheel, *O*, on the upper shaft, *P*. On this shaft also is an eccentric oval wheel, *Q*, driving a corresponding oval wheel, *R*, fast on the back end of the crank disc shaft, *M*, which passes through the head of the column. This equalizes the motion, or makes the traverse uniform, and effects the quick return of the cutter after each cutting stroke, as in the common planing machine.

The other motions are actuated by a pulley, *S*, on the end of the cone, *L*, a strap from which pulley passes to a pulley on the long shaft, *T*, which is geared to the mandril, passing vertically through the socket, *U*, with intervening wheels to vary the speed; and a cross shaft, *V*, connected with a large horizontal inverted bevil wheel, concealed beneath the face-chuck, *W*, in such a manner as to allow for the various motions and adjustments of the latter.

At *X* is the traversing or bed slide, on which the saddle, *Y*, of the table moves; and *Z* is a superincumbent piece, capable of being tilted by means of screws, and having the socket, *U*, descending into a pit in the foundation, so as to lower the face of the chuck for the reception of heavy work. Beneath the face-chuck is a slide, *A*, attached directly to the mandril.

A contrivance, *B*, is introduced for raising the mandril when the machine is used for turning, allowing it then to revolve freely, whilst it can be let down solid for slotting. The face-chuck, *W*, is connected with the inverted bevil wheel before mentioned, by projecting clutches, so that the wheel is not affected by the raising of the mandril. The piece, *A*, is graduated on its circumference for prismatic and angular shaping.

The tool slide, *C*, can be screwed on in two positions at right angles, and at different heights; it gives a fine adjustment for circular cutting, being removed when the tool cuts rectilinearly.

The various feeds, which are entirely self-acting, are worked thus:—The shaft, *V*, is moveable longitudinally by a spiral groove, so that when the back bevil wheel, for driving the mandril for circular cutting, is thrown out of gear, a screw wheel at its near end may be connected with the tangent screw, *D*, giving a feeding motion for shaping circular works, as the bosses of cranks, by rectilinear cuts. This tangent screw is worked from a rod, *E*, actuated by a face-groove cam on the main shaft, *M*, and having a screw-adjusting and reversing movement. The cam is also

Fig 1

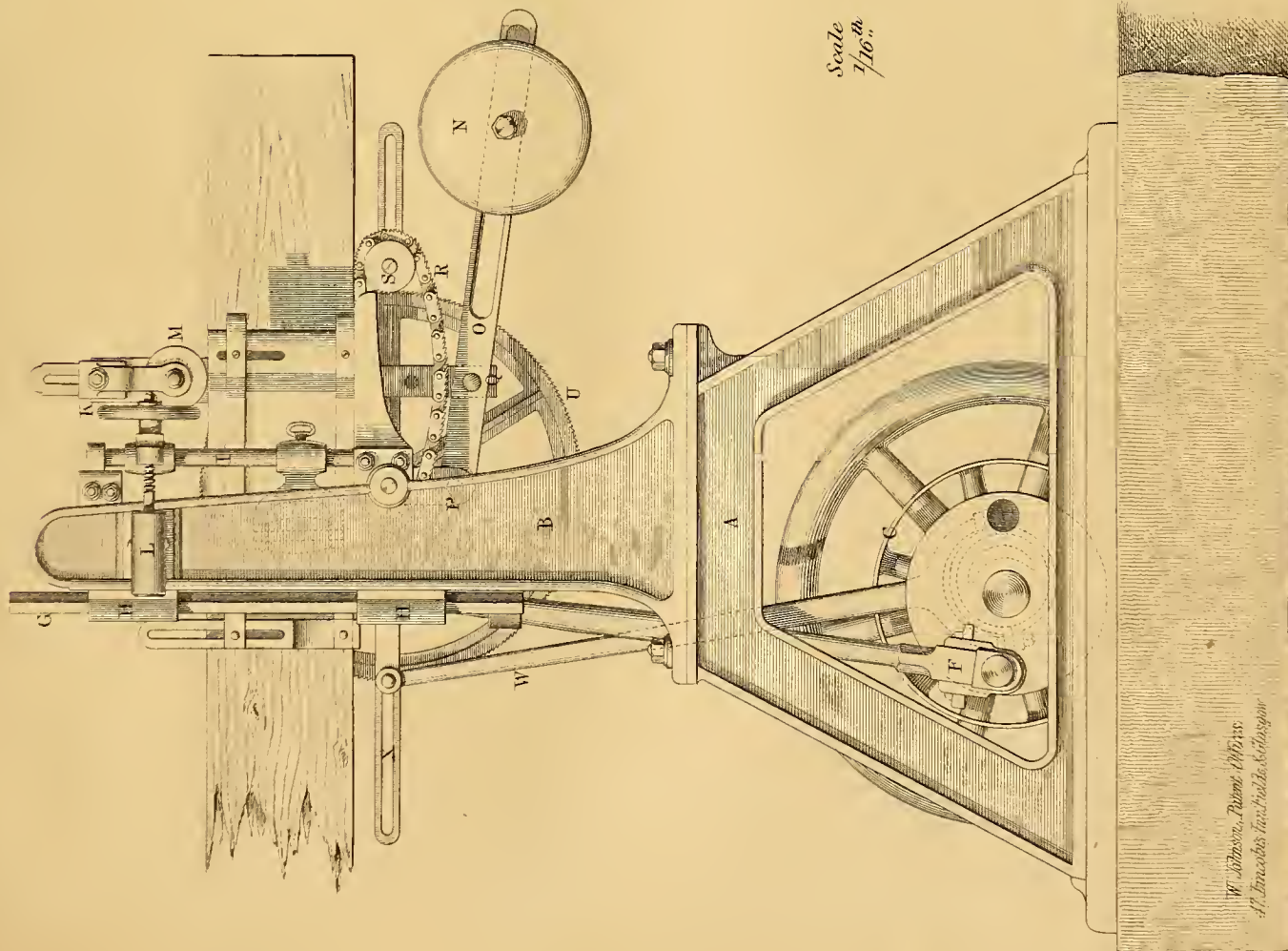

Scale
1/16"

W. Johnson, Patent Engineer,
47, Strand, London.

Fig 2.

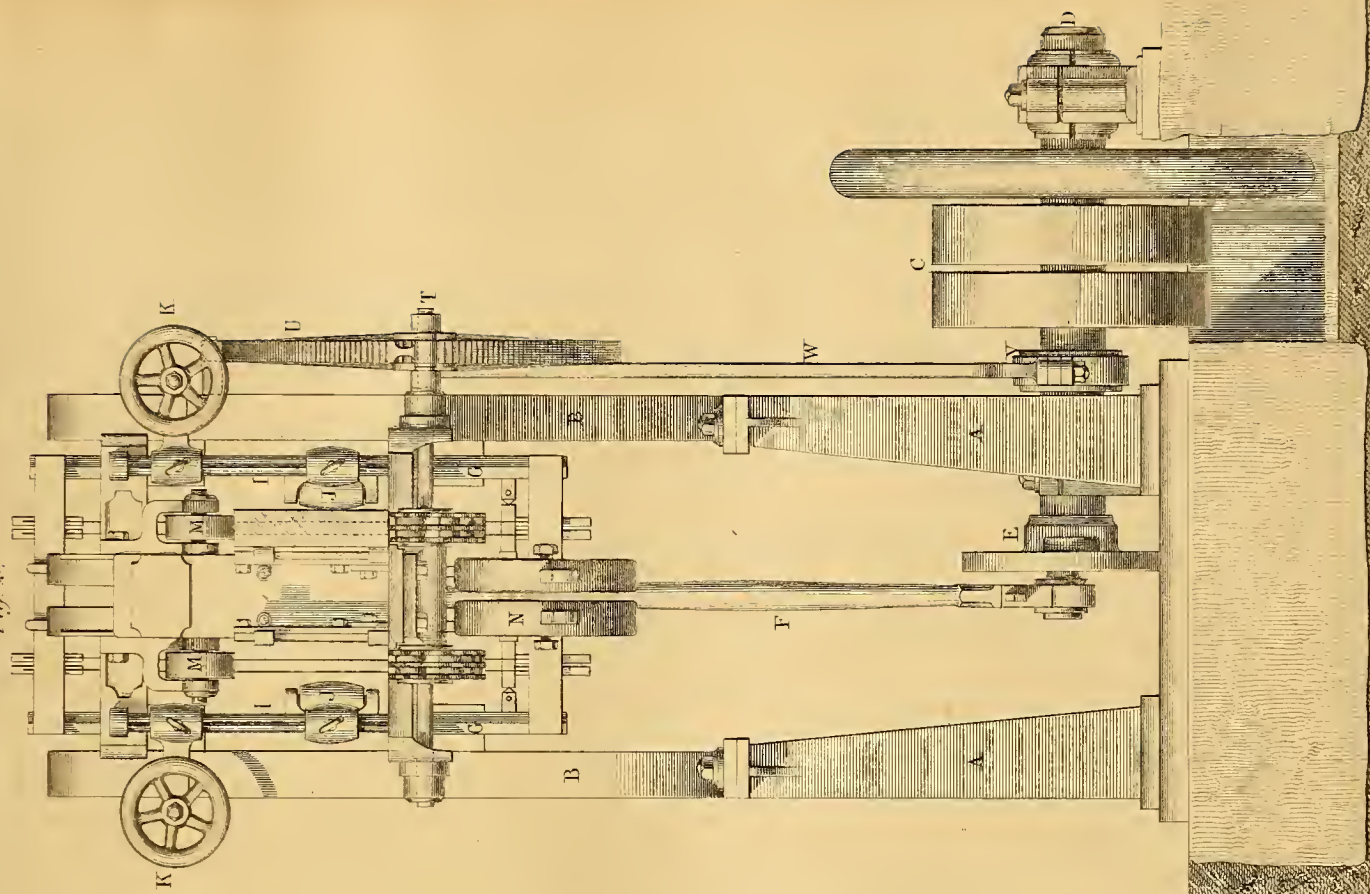



In. 12 6 0 1 2 3 4 5 6 Feet

G. P. RENSHAW, PATENTEE,
NOTTINGHAM.

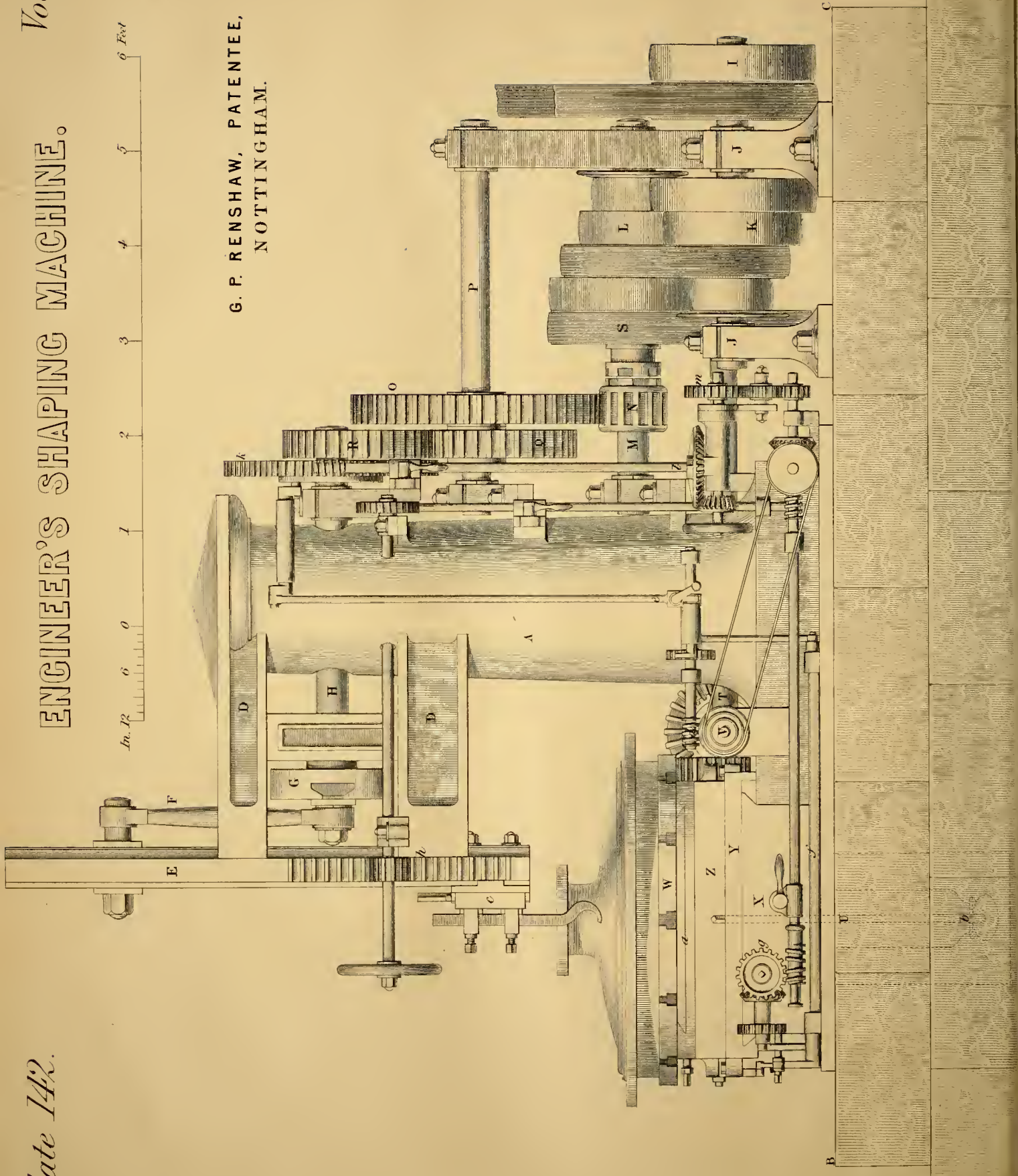

connected with a shaft, *f*, giving the other two intermittent feeds required for rectilinear cutting, with the crank motion, *e*, in action—namely, those for the slides, *x* and *a*.

The continuous feeds, *g* and *h*, are driven by a belt, *i*, with cone pulley, and suitable intervening arrangements for disconnecting the parts, and a peculiar method is contrived for reversing the continuous traversing feed at *g*. For this purpose, the actuating worm-shaft carries a right and left-threaded worm-wheel opposed to, or reversed, as regards each other. This compound worm is fitted to a corresponding duplex worm-wheel, so that either the right or the left thread may be put in gear. This plan is also suitable for other purposes, and particularly as a substitute for the motion commonly used in rack lathes; being cheaper, as dispensing with three spur-wheels, and more convenient, as the whole of the hand-gear can thus be carried on the rest-saddle.

The machine is thus complete for turning and boring, as well as for slotting and shaping, circular, rectilinear, and prismatic work; and by tilting the table, taper and angular work of each class may be executed; so that a great number of the most common parts of machinery may be completely finished, when once adjusted and fixed on the face-plate. It unites, indeed, all the solidity and convenience of the respective detached machines of the engineer's workshop. The arrangement of the table is also more convenient than that of the common slotting machine. In the latter, as the circular or worm feed is above both the rectilinear slides, it is necessary to shift the work, when it is wished to place it eccentric, for instance, in consecutively paring the bosses of a crank; in the present tool this is accomplished by placing the slide, *a*, at the top, this position not interfering with its self-acting feed.

The machine is also capable of turning round and hollow surfaces, by the addition of a screw-wheel, *k*, on the main shaft, *u*, connected at pleasure by means of a rod, *l*, and change-wheels, *m*, borrowed from a screw-cutting lathe, with the continuous self-acting feed at *i*, the required are being obtained by the adjustment of the crank-pin in the disc, *e*. When this curvilinear motion is put in gear during the revolution of the work on the mandril, the machine assumes all the functions of that rare engine, the spherical lathe; and as the extra parts are few and simple, and do not at all interfere with the solidity of the tool, and are, besides, capable of working all curves between a straight line and a hemisphere, convex or concave, and their combinations, new uses will easily suggest themselves. It is shown in the act of facing a cylinder cover with a compound curvilinear self-acting cut.

When the work is of very large diameter, and revolves, the turner sits on a cross plank.

THE SOCIETY OF ARTS EXHIBITION.

The "Collection of Articles Invented, Patented, or Registered, since October, 1852," forming the fifth of the very excellent exhibitions of the Society of Arts, has been opened since the appearance of our last number, and we are glad to find that its reputation achieved in previous years, has not in any way receded in the present one.

The *Catalogue* tells us that the room contains 231 articles. These are divided under the six heads of—

1. *Motive Machines, including Railway Mechanism.*
2. *Manufacturing Machines and Tools.*
3. *Building Contrivances and Materials, and Naval and Military Mechanism.*
4. *Philosophical Instruments and Hardware.*
5. *Agricultural Implements and Saddlery.*
6. *Miscellaneous, including Articles for Personal and Domestic use.*

In the first Class, Mr. J. C. Pearce, of the Bowling Iron-Works, Yorkshire, contributes four drawings, illustrative of his late improvements in steam boilers. In these boilers, arrangements are made for the purpose of causing the heat first to take effect as near as may be on the surface

of the water, and then to traverse the tubes lower down, finally acting upon the bottom and outside of the boiler, prior to passing off to the chimney.

Fig. 1 is a longitudinal section of a portion of a tube, showing Mr. Pearce's mode of fastening the flue-tube ends to the tube plates of his boilers. A short tube or ferrule, *A*, is soundly welded upon each end of the tube, so as to form strong end collars, and these enlargements are then turned down slightly in the lathe, to fit accurately to the hole in the tube plate. When properly adjusted in the tube plates, the projecting edges of the collars are riveted or caulked over with the hand hammer, as at *B*. As to the breadth

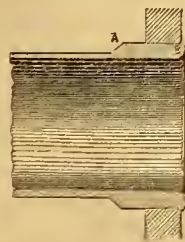

and thickness of these collars, $1\frac{1}{4}$ inch by $3\text{--}16\text{th}$ inch answer for ordinary tubes, the outsides of the collars being $3\text{--}8\text{th}$ inch larger than the bodies of the tubes. This system of fixing materially strengthens the tube ends, preventing them from splitting, and at the same time allowing free passage for the heated current. Such tubes may also be put in from either end of the boiler, whilst they are as easily withdrawn, without reference to the presence of scale on their external surfaces. The same inventor exhibits a mode of protecting the glass gauge tubes of boilers, by casting soft metal, such as tin or lead, upon the tubes, leaving a longitudinal slot in each case, through which to see the position of the water level.

Mr. Ramsbottom, the locomotive superintendent of Longsight, near Manchester, exhibits a 15-inch locomotive engine piston, embodying some good points. The packing-rings in it are originally made 10 per cent. larger in diameter than the piston, and they are therefore kept well up in working contact with the cylinder by their own elasticity. This 15-inch one weighs 84 lbs. The first pair put to work have performed 18,000 miles.

Messrs. Manifold and Lowndes, of Liverpool, have a drawing of their "Combined Expansion Engine." This is a clever modification of Woolf's, or the double-cylinder expansion engine, wherein the high and low pressure cylinders are combined together, to act at right angles to each other on one crank. This arrangement enables each cylinder to help its neighbour over the dead centres, the relative powers of the high and low pressure cylinders being so proportioned, that each shall give out the same amount of power, to secure uniformity of motion and strain. Thus all the acknowledged economy of the double-cylinder expansion process is secured, in combination with that uniformity of action hitherto unattainable in engines of this class.

Messrs. J. Bourne & Co., of Glasgow, are represented by the "Conchoidal Marine Propeller" of Mr. C. A. Holm. The novelty of this contrivance consists in a peculiar combination of curved surfaces, or spoon-shaped edges of the blades, the object of the inventor being to concentrate and direct the propelling current at the circumference, in such a manner that it shall be delivered in a line parallel with the propeller's axis, and prevent loss from centrifugal slip.

Messrs. W. and J. H. Johnson, of Lincoln's-Inn-Fields, exhibit eight very large mounted finished sheets of engineering drawings, including in this section most elaborately executed views of the "Austrian Prize Locomotive 'Bavaria,'" as made by Herr Maffei, from the designs of Mr. Joseph Hall for the Semmering Railway, and Mr. McConnell's "Express Locomotive on the London and North-Western Railway." Also, Bellhouse's "Twin Steam-Boiler," Scott, Sinclair, & Co.'s "Double-gear Marine Engines for Screw Propulsion," and the "Engines of the *Duncan Hoyle* Screw Steamer," by the same makers. In division 2, the same exhibitors have Mr. J. Jones' "Iron Refining and Puddling Furnaces," Messrs. J. James & Co.'s "Weighing Machine," Mr. Fearn's "Metallic Ornamentation," and a valuable collection of "Engineer's Tools," including Shanks' "50 Ton Slotting Machine," M'Dowall's "High Speed Tensional Sawing Machine," and two of Mr. Renshaw's excellent "Engineer's Shaping Machines;" Mr. Bridson's "Washing Machine for Textile Fabrics," Mr. Bower's "Gas Retorts and Combined Gas Apparatus," Mr. Glasson's "Oval Tube Boiler," and Messrs. Scott, Sinclair, & Co.'s "Charcoal Kilns and Vacuum Sugar Pans."

Several gold-producing machines are prominent objects in this division. The "Self-adjusting Screw Bolts" of Mr. G. W. Nicholson, of Pendleton, are intended to prevent the straining and breaking to which ordinary bolts are in some degree liable. This is accomplished by making the under surface of the nut and the bolt-head of a convex form, using concave washers, which adjust themselves to the inequality or obliquity of the surfaces being bound together.

Messrs. Purbrick and Yeates, of Tunbridge, contribute the patent Sugar Pans of Mr. R. B. Purbrick, who, in his arrangement, secures superior rapidity of evaporation. The pans present a larger area of effective beating surface than usual, and they possess several other practically important features which the sugar-boiler will duly appreciate. The pans are made by Messrs. Blyth, of Limehouse.

In Class 4, Messrs. W. and J. H. Johnson contribute a drawing of Dr. Watson's "Electric Lamp, of continuous and automatic action," showing all the details of that elegant contrivance.

In Class 5, Mr. Wilson's "Patent Cottage Allotment" and "Navigator's Barrows," as made by Mr. George Ell, of the New Road, are creditable, as well for their mechanical construction as for their original design.

Fig. 2 is a longitudinal section of one of these barrows. The wheel or "trundle" is placed under, and is recessed into the bottom of the barrow, the internal projection being covered over by a piece of curved sheet-iron, boxed in with wooden side-pieces. With this position of the wheel, the

weight of the contained load is thrown upon the wheel, instead of being carried between the hand and the wheel, as in the common barrow, thus relieving the labourer's arms. The sinking of the body over the wheel also brings the weight nearer to the ground, and diminishes the working oscillation. The handles are attached quite separately from the body, and they are set on at a considerable angle, so as to reduce the lift in

Fig. 2.

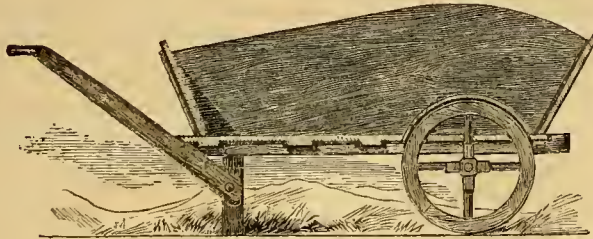

wheeling. Where nicety is required in wheeling, as in going over a plank, a brass knob is set on the top of the front board, at the middle, so as to be directly in the line of the wheel, and serve as a guide; and to prevent the dirt from clogging the wheel cover, a scraper is attached behind the wheel.

In Class 6, the "Patent Cask-cleaning Machine" of Mr. R. Davison, of Mark-lane, attracts attention, from the efficiency of the very simple means adopted for cleansing brewers' casks from all internal adhesive matter, without resorting to the destructive and expensive process of unheading. Fig. 3 is a side elevation of the cleanser complete, with the cask being operated upon in section. The system adopted by Mr. Davison consists in the giving continuous rotation to the cask, as held in an open frame, in a direction at right angles to its axial line, whilst it is also made to revolve upon its own axis in the frame, by a most ingeniously contrived movement of a weighted or pendant lever, and an "endless screw." The

Fig. 3.

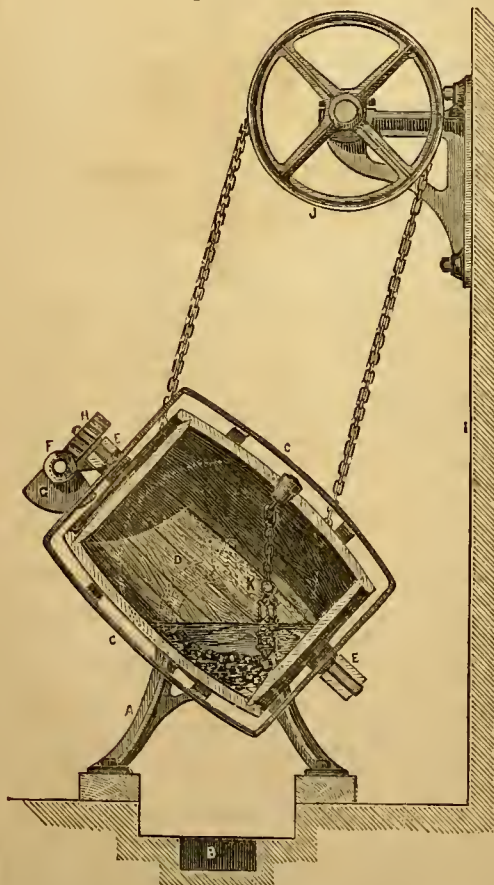

framing in each case consists of a pair of open standards, A, bolted down to wooden hearers on the floor, over the top of an open drain grating, B. These standards are formed with bearings, to receive the end journals, forming the transverse axis of the open frame, C, in which the foul cask, D, is placed for cleansing. The journals, E, at the two opposite ends of the frame, C, answer as the major axis of the frame and cask, their bearings being in an outer secondary frame piece, shown in section, and suspended from the minor axis of the movement. Thus these two frames form a species of universal joint, the outer one revolving only upon the minor axis, whilst the inner one partakes of a movement compounded of that revolution and the revolution upon its own immediate axis.

The outer frame carries at one end a bracket-piece, to form hearings for a worm or endless screw-spindle, F, to which is attached a weight, G, fast on the spindle. The worm gears with a worm-wheel, H, fast on the major axial spindle, E, of the inner frame, C.

The cleansers are placed in a row on the ground, alongside a wall, I, to which brackets are bolted, to carry a continuous overhead shaft, fitted with chain pulleys, J. Each of these pulleys has an endless chain passing down to a corresponding pulley on the carrying spindle of the apparatus; so that, as the whole revolves, the secondary rotation of the cask upon its own axis is obtained from the pendulous action of the weight, G, in holding back the worm, which thus causes the rotation of the wheel, H. The cask, therefore, revolves in every possible direction, and the cleansing fluid in the interior has its effect powerfully increased by the spiked chain, K, suspended from the bung, the angular surfaces of the chain being made to act upon every portion of the cask. The cost of this cleansing is no more than about one halfpenny per cask.

We shall return to the consideration of this most interesting collection next month.

MECHANIC'S LIBRARY.

Agriculturist's Almanac, Scottish, 1854, 12mo., 1s., cloth, sewed. Morton.
Agriculture, Essays on, post 8vo., 5s. Gisborne.
Builder's Price Book, 1854, 8vo., 4s., sewed. Skyring.
Chemistry, Hand-Book of, 8vo., 15s., cloth. Abel and Bloxam.
Euclid's Elements, new edition, foiseap 8vo., 3s. 6d., cloth. Ebrington.
Gold Rocks of Great Britain and Ireland, 8vo., 10s. 6d., cloth. Calvert.
Inorganic Analysis, Hand-Book of, by Hofmann, 6s. 6d. Wöhler.
Literary and Scientific Register, 1854, 18mo., 3s. 6d., tuck. Gutch.
Mathematical Course for the University of London, 9s. Kimber.
Million of Facts, new edition, crown 8vo., 12s., cloth. Sir R. Phillips.
Ordnance School, Examination Papers of, 8vo., 5s. 6d., cloth.
Photography, Guide to, crown 8vo., 2s., sewed. W. H. Thornthwaite.
Positive Philosophy, translated by H. Martineau, 2 vols., 16s. Comte.
Practical Astronomy, Introduction to Elements of, 7s. Christie.
Rural Architecture, 12mo., 1s., sewed. J. Sanderson.
Science, Marvels of, Illustrated, 6th edition, post 8vo., 6s. 6d., cloth. S. W. Follon.
Tree-Lifter, 2d edition, 8vo., 12s., cloth, coloured. G. Greenwood.

RECENT PATENTS.

FLOUR MILLS.

JOHN CURRIE, Glasgow.—Patent dated October 21, 1852.

The efficient mingling of cold air with the grain as it passes between the grinding surfaces of millstones, is one of the most important of the modern improvements in grinding. The operating surfaces are thus kept cool, and the production is materially increased, whilst the quality of the flour is very superior to that produced in the old way. It is this feature which holds a prominent place in Mr. Currie's invention.

Fig. 1 of our engravings is a vertical section of one of his millstone arrangements, showing how the cooling air is mingled with the grain before it passes to the grinding surfaces. For this purpose he uses two grain feed-pipes, A, diverging downwards, like a forked branch of a tree, from the narrow bottom discharge opening of the hopper, B, the revolving feed-spindle, C, being passed up from the main spindle, D, through a joint-hole in the fork, into the main feed-pipe, receiving the grain from the hopper. After diverging downwards, until they reach the upper surface of the fixed stone, E, the two feed-pipes pass vertically through a pair of holes made directly through the upper stone, and set diametrically, one on each side the eye of the stone. An annular portion of the under surface

Fig. 1.

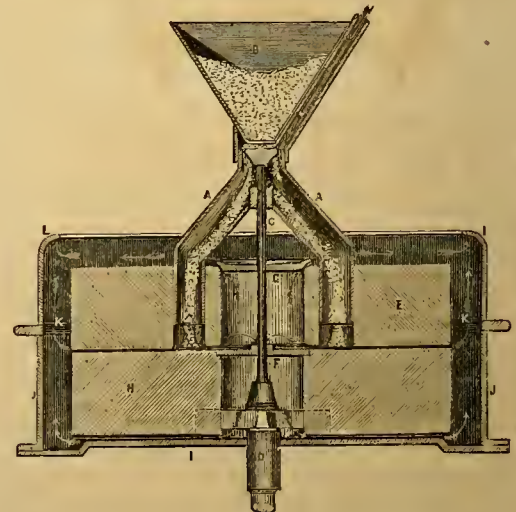

upon the minor axis, whilst the inner one partakes of a movement compounded of that revolution and the revolution upon its own immediate axis.

of this stone, extending far enough to reach the feed apertures opening through it, is bevelled slightly upwards from the outer side of these holes towards the eye, so as to leave a narrow space between the two stones at this part, for the free entry of the grain and air, and precluding the chance of the commencement of the grinding action, before the air has fully reached the acting surfaces. The eye of the upper fixed stone, between the two feed-pipes, is covered over with a metal disc, *e*, passed over the feed-spindle, and capable of adjustment at any required height above the eye as a valve. The grinding surface of the lower running stone, *n*, is perfectly flat throughout, and its eye at the grinding level is covered over by a metal plate, *f*, with a central aperture round the feed-spindle, *g*, for the passage through of a portion of the air. In this way, part of the air may be discharged at the eye of the upper stone, and part down through the eye of the runner beneath, whilst the main body of the air goes along with the grain, and is discharged with the grained material at the periphery of the stones. By this contrivance the entire surface of both stones is kept encircled by a constantly changing air-bath or current, for the air, escaping at the eye of the upper stone, is directed by the valve disc over its entire surface, whilst that from the bottom of the lower eye passes over the whole bottom surface of the runner, between it and the bottom base plate, *l*. This has a ventilating effect; for on the upper edge of the iron casing, *j*, which surrounds the lower running stone, and supports the upper fixed stone, is placed an annular disc of wire-cloth, *k*, covering over the annular space left between the periphery of the stones, and the interior of the casing. This wire-cloth stands a short distance above the level of the grinding surfaces, and from its periphery a light wooden casing, *l*, springs upwards, surrounding the upper stone, and bevelled inwards at some

Fig 2.

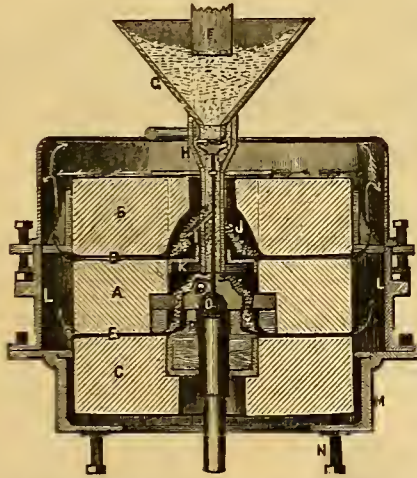

distance above the stone's surface. Thus there is a current of cold air passing from the running eye up outside the stone and inside the casing. There it meets the heated current from the grinding surfaces at right angles, and breaking this heated current, whatever grained material is held in suspension, whilst the heated air passes off through the wire-cloth, again meeting at right angles with a cool current from the upper side of the top stone, which, in conjunction with the bevelled top of the

upper case, still further separates the suspended flour, and aids the ventilation. Another modification of stones relates to the combination of three or more separate stones, instead of two, as hitherto used. In this plan, which is represented in fig. 2, the central stone, *A*, is the runner, the upper and lower ones, *B*, *C*, being fixed, so that the grinding is performed both between the under surface of the upper stone at *d*, and the upper surface of the central runner—and between the under surface of the latter, and the upper surface of the bottom fixed stone at *e*. The grain is fed through the pipe, *f*, into the hopper, *g*, through the adjustable feed-passage into the pipe, *h*. Hence the supply for the upper grinding surfaces passes out by the inclined lateral opening, *i*, into the hollow space, *j*, in the upper stone, forming the lower part of the eye thereof. Here it falls on to the disc, *k*, and is directed to the grinding surfaces. The supply of grain for the lower or secondary grinding action passes out at the bottom of the pipe, *h*, into the eye of the runner, *A*, and thence proceeds to the grinding surface. The upper stone is supported by side brackets, these brackets being carried on the lower annular casing, *l*, bolted down to the floor. The bottom stone is sunk in a casing, *m*, recessed into the floor or platform, being steadied laterally by an annular piece of metal level with the floor, whilst it rests on adjusting bolts, *n*, beneath. The spindle driven by gearing from below, rests in an adjustable balanced footstep. It is fitted to the runner by a *Ryne* made on the "balance" principle. The top of the spindle is spherically shaped as at *o*, being passed through the collar disc, *p*, and fitted into a spherical recess in the under side of the *Ryne*, *q*, connected to the stone, *A*. In

this way, as the connection between the spindle and the stone is entirely

formed by this ball and socket, no derangement can arise from the spindle and runner getting out of truth.

Fig. 3 is a vertical section of the "balance Ryne," on a larger scale. *A* is the base plate, and *B* the lower running stone, driven from above by the main spindle, *i*, which passes down through the centre of the adjustable tubes of the feed-hopper, and terminates in a convex foot. This foot rests in a concavity in the top of the disc piece, *d*, which has formed upon the centre of its lower surface a spherical journal or step piece, resting in a brass carried in the top of the adjustable block, *e*. The bottom of the spindle has a transverse piece, *j*, forged upon it, and arranged to gear into slots in a projection standing up from the upper face of the disc piece, *d*, so that the spindle cannot revolve without carrying this disc with it. This disc is secured vertically to the upper disc of the Ryne by bolts passed up from below, and it is adjustable laterally by set screws passed through the vertical arms of the Ryne, *c*, and bearing against the disc's periphery. These vertical arms terminate in an annular piece, from which projections pass into corresponding internal slots in the lower end of the eye of the stone. A large box piece, *k*, is firmly wedged into the eye of the runner from above, covering up the whole of the *Ryne* apparatus, and this box piece has an upper collar upon it, through which side bolts, *l*, are passed. These bolts pass as well through the feed-cup piece, *m*, and finally bear upon the spindle which passes through the cup piece and into the box. By this arrangement the full benefit of the universal joint connection is obtained, as the bolts admit of exact lateral adjustment, and the stones will work accurately, even if they should get out of truth with the spindle. The

bottom block, *e*, rests on the top of the screw bolt, *f*, which works in a brass nut, the latter carrying a notched disc, *g*, for turning by the adjusting lever, *h*. The forked end of this lever embraces and is jointed to a loose ring by a pin on each side, so that the lever may be engaged and disengaged from the notches in the disc at pleasure. In this way, as the disc is fast to the brass, the attendant, by urging round the lever when engaged in one of the notches, can screw up the spindle and thus raise the block, *e*, as may be required. This movement resembles that of a ratchet-drill, wherein a few short strokes, and a succession of engagements with the disc notches, give a considerable power of traverse. The block, *e*, is capable of being fixed by a set screw, passed through the projecting bottom collar of the base plate.

Many of these improvements are now at work, at the patentee's extensive and well-arranged "City of Glasgow Grain Mills."

Fig. 3.

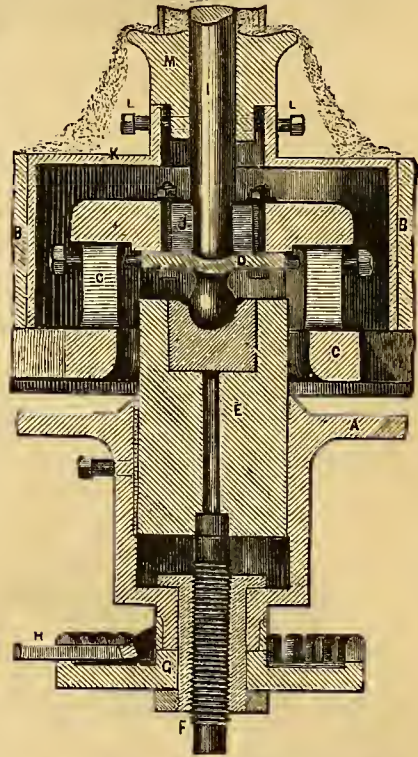

BASKET-WORK CARRIAGES.

JAMES EMERY, Preston.—Patent dated April 25, 1853.

Mr. Emery, whose ingenious wicker-work "skips" have already been noticed in this *Journal*, substitutes cane and wicker-work for wood in the bodies of gigs, dog-carts, and other vehicles, in a very efficient manner. Our sketch is a perspective view of such a dog-cart body. The frame, *A*, of the vehicle is of the usual construction; but, instead of being filled up with wooden panels, these are replaced by strong cane-work, or combined cane and wicker-work walls, as at *B*. In constructing this kind of frame-work, strong vertical canes, *c*, are let into holes, and fixed to the top and bottom horizontal pieces of the frame. At certain intervals, iron rods, *d*, are used in place of the canes, to increase the strength, and also

to bind the frame firmly together, the rods passing through the frames, and having a head at one end, whilst they are riveted upon washers at the other end. Horizontal cross canes or willows are interwoven with the uprights, *d*, as at *e*; and where willows are used, this interweaving

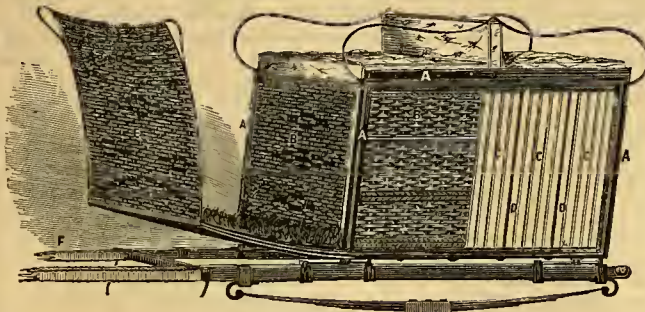

may be made to produce any pattern or device, such as is met with in other kinds of wicker-work. The splash-board, *e*, is composed of cane and wicker-work, combined in a similar manner. He further binds the shafts of vehicles in general with cane, as at *f*, in order to strengthen and defend them, and prevent them from splitting. In constructing carts and other heavy vehicles, he uses an inside lining of boarding, so that they may be used for any purpose.

FLUSHING APPARATUS.

JOSEPH ADAMSON, *Engineer, Leeds.*—*Patent dated April 14, 1853.*

Our illustration of the improvements comprehended under this patent, is a vertical section of a self-acting flushing cistern, which Mr. Adamson employs for flushing sewers and other passages. The receiver or cistern, *a*, has at one end a fixed siphon, *b*, of the entire width of the cistern, and contracted slightly at its lower discharge orifice, *c*, opening into the reservoir or funnel mouth, *d*, on the top of the vertical conducting pipe, *e*. This pipe communicates with the locality to be flushed at the periodical

discharges of the flushing cistern. The latter is suspended on a pair of knife-edged or slightly rounded pivots carried by the bracket supports, *g*. These pivots are set a little out of the cistern's centre—this eccentricity being

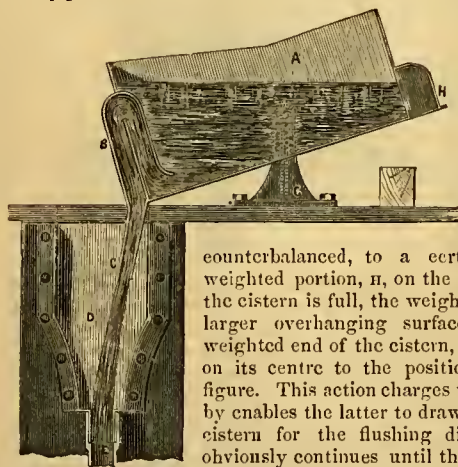

counterbalanced, to a certain extent, by the weighted portion, *h*, on the shorter end. When the cistern is full, the weight of the water on the larger overhanging surface, overbalances the weighted end of the cistern, and causes it to turn on its centre to the position indicated in our figure. This action charges the siphon, and thereby enables the latter to draw off the water in the cistern for the flushing discharge. This flow obviously continues until the weight of water at one end of the cistern is so much reduced, as to be

overbalanced by the dead weight at the other end, when the cistern regains its original horizontal position on the stop, *j*.

By this system, a regular periodical discharge may be kept up, the action being regulated by the quantity of water allowed to flow into the flusher. In water-closets, the patentee proposes to combine the flushing cistern and basin in one vessel.

MANUFACTURE OF CASKS.

J. ROBERTSON, *Glasgow.*—*Patent dated November 15, 1852.*

In making casks and other wooden vessels, according to this invention, the rough staves are first steamed in the usual way, to cause pliability; and then, in order that the irregularities or hends in the wood may be nullified, the stave is screwed up by its flat side against a fixed bearing surface, or against rollers, so that, when passed into the sawing-machine, the wood may be accurately cut—a self-acting arrangement being employed in connection with these retaining or flattening screws, for the purpose of slackening off these holding details, as each approaches to the

cutting edge. At the same time, a series of cutters is arranged to work on the exposed side of the stave, for the purpose of dressing that surface to the form required. The staves, so prepared, are then conveyed to a second machine, where they are held flat down by screws on a traversing table, moving in the line of curve intended to be given to the edges of the staves. As the stave moves forward, it is first sawn on the edge by a circular saw, to take off the "overwood" to the required curve, and it then comes against a set of rotatory cutters to finish the surface. At the same time a set of cutters work over the top of the stave, on its flat surface, for shaping such surface as required. Then, when this flat side and one edge have been so shaped, the stave is reversed, and the other side and edge are similarly treated. Several staves may be simultaneously worked in this way. And the staves so prepared, or indeed in their rough state, may be planed or shaped off evenly by passing them upon or over a table, beneath a roller or pressing guide, which shall act upon the stave so as to flatten down its irregularities, whilst a rotatory or other cutter is set to work above the stave surface, immediately that the stave emerges from its pressing roller, and whilst still flattened down by such roller. When the staves are piled together, or when the "cask is raised," the upper ends of the staves being surrounded by a hoop, the mass of staves is put into a press, to compress the bilge of the cask, and bring together the bottom or opposite loose ends of the staves.

Our illustrations represent the second machine in Mr. Robertson's series. Fig. 1 is a longitudinal elevation of the machine, and fig. 2 is a corre-

Fig. 1.

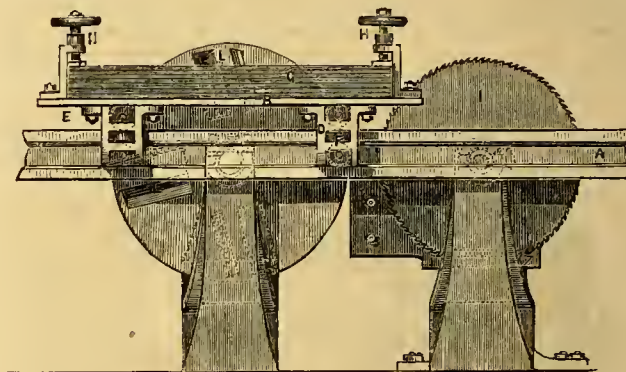

sponding plan, the framing being broken away in both views. The framing consists of a single long curved or segmental table, *a*, slotted down the centre, and supported on two end staudards on the floor. Upon this segmental table is set the traversing carriage, *b*, which has four sup-

Fig. 2.

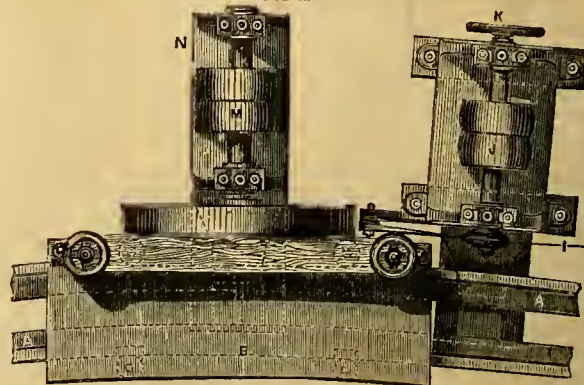

porting pulleys, *d*, set on stud centres, to run upon projecting rail ribs on the upper surface of the table. These pulleys are carried in the four side brackets, *e*, bolted to the table, and serving also to carry the four bottom pulleys, *f*, bearing against rail strips on the lower side of the edge flanges of the table, as well as four other horizontal pulleys, *g*, bearing against the external parallel edges of the table flanges. By this arrangement, the carriage, *b*, is accurately guided upon its table, both vertically and horizontally. The partially prepared staves, *c*, are now laid, several together, upon the surface of the table, *a*, being firmly held down thereon by the hand-wheel screws, *h*, working through bracket

nuts, holted to the carriage surface. The circular saw, 1, for taking off the "overwood" from the stave edges, is driven by the pulleys, 3, provision being made for setting the saw up to its cut by the hand-wheel, 5, actuating a traverse screw arrangement. As this saw revolves at the required speed, the pile of blanks is traversed up against it by hand, or in any other convenient way, and the rough edges of the staves are thus taken off to the curve of the table, A, which coincides with that intended to be given to the staves. After leaving the saw, the sawn surfaces of the staves are immediately submitted to the action of the rotatory disc-cutters, L, driven at a high velocity by the band pulleys, M, being carried on a separate standard, X. This completes the shaping of the "gored" staves on one edge; and whilst this action is going on, a second disc-cutter, which is not represented in the figure, may be arranged to shape the upper flat surface of the exposed stave. This contrivance, which is only conveniently applicable when a single stave is treated at once, is to be carried into effect by disposing a separate standard alongside the machine, to carry a vertical spindle, having upon it a horizontal cutting-disc. When one edge and the top have thus been treated, the stave is reversed, and the opposite surfaces are then similarly shaped, and this completes the process. The essential advantage of this arrangement of holding-down screws is, that whatever twist may be in the staves is taken out of them for the time being, whilst the cutting action proceeds, so that an accurate plane surface is secured, quite irrespective of such twist, and the pieces then return to their shape on being released.

Mr. Robertson has long been creditably distinguished, not only as an inventor, but also as a practical worker-out of cask-making machinery. Several extensive factories are now in operation on his plans, and these must now derive considerable benefit from the modifications which we have here described.

STOP-COCKS.

HENRY WILKS, *Brassfounder, Rotherham.*—*Patent dated April 16, 1853.*

Fig. 1.

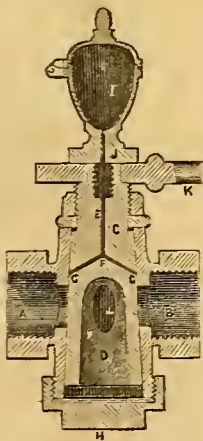

The lower portion of the oil-cup is expanded at J, to form a hase, which expansion serves to retain the small lever or handle, K, on the square head of the plug.

Fig. 2.

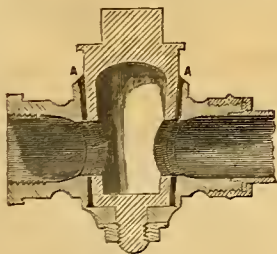

Fig. 2 is a similar section of a lined gas-cock, the part A being the inserted lining, the use of which obviates the necessity of grinding the working surfaces.

AIR MOTIVE ENGINES.

J. R. NAPIER and W. J. M. RANKINE, *Glasgow.*—*Patent dated June 9, 1853.*

This is another attempt at the development of an economical motive agent, on the principle of that with which the name of Ericsson has been so often heard in late years. Our sketch represents a vertical section of one of the air receivers, as communicating with the upper portion of the actual working cylinder, a precisely similar apparatus being arranged to work in connection with the lower end of the main

cylinder. The chamber, A, has within it a plunger, B, fitted with a set of vertical rod-shaped plungers, C, which slide inside the closed tubes, D, in the water-tank, E. Two rods, F, give the requisite traverse to the plunger, which has a central circular opening, G, filled with wires or loose strips of metal. A pipe, H, forms the communication between the receiver and the top of the cylinder. At I, is a heat screen, composed of a series of rod-shaped plungers, J, working loosely within the closed tubes, K. These plungers are fitted upon a perforated plate, L, which receives a traverse movement from a central rod, M. The tubes, K, are contained within the closed chamber, N, heated by a furnace, and heated air entering by the flue, O, and flowing off by the flue, P, to the chimney.

When the plunger, B, is lowered in the receiver, A, it sends the air through the passage, G, to the top of the receiver, and into the tubes, D, in the water-tank, so that such heat as may have reached it from the flame will now be abstracted. At the same time, the plunger of the corresponding apparatus for the lower part of the cylinder, will be lifted to the top of its traverse, sending the air out of the upper tubes, and the upper portion of the body of the receiver, down through the central permeable mass, or passage. The heat screen, I, is also lifted and dropped, the effect being that the air in the lower part of the receiver, A, is made to circulate rapidly over the surface of the rods, J, and through the heated tubes, K, thus taking up a certain quantity of heat. The consequent expansion of this heated air then produces pressure through the passage leading to the top of the cylinder, so as to act upon the working piston.

During the end of the down stroke and the commencement of the up stroke of the piston, the heat screen lies at the bottom of the receiver. The plunger, B, descends, and the air, with the exception of a trifling quantity, passes through the permeable mass, G, giving out a large portion of its sensible heat to the wires therein, the rest of the heat being abstracted by the water in the tank, E. During the end of the up stroke and the beginning of the down stroke, the plunger, B, rises, the air descends through the passage, G, and takes up from the wires the greater part of its sensible heat, formerly lost.

During the first half of the down stroke, the heat screen is raised and dropped, and the air, by circulating over the rods, J, and through the heated tubes, K, acquires the rest of the sensible heat necessary to elevate its temperature, and also the latent heat necessary to expand it. This completes the routine of operations in the receiver connected with the upper end of the cylinder. The movements for the other end are precisely the same.

COMPOUND RAILWAY JOINT CHAIR.

J. BELL, *Portobello.*—*Patent dated December 14, 1852.*

Mr. Bell's compound chair consists of two ordinary chairs cast in one piece, the connection being by an extended intermediate portion of such a form as to fit to and support the bottom and both sides of the rail. It is more particularly applicable for joints, and when so used, the ends of the two contiguous rails are slipped through the chairs into the hollow of the intermediate portion.

Our engraving represents the chair in plan, with the rails and keys removed. The intermediate piece, A, is in the form of a long trough, one side, B, of which runs right through from end to end across the chairs, whilst the other, C, is somewhat shorter. The inner surfaces of these ledges, B, C, are made to fit to the

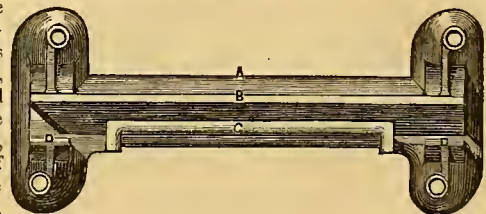

sides of the rail; and the jaws, *d*, of the end chairs are set back far enough to leave room for the usual wooden keys to bind the rail in its place. It is thus pretty obvious, that the intermediate trough-piece answers as a fish-joint.

RAISING AND LOWERING WINDOWS.

F. RUSSELL, *Clarence Gardens, Regent's Park, London.*—Patent dated May 25, 1853.

The object of Mr. Russell's invention is the facilitating the raising and lowering of windows, shutters, and blinds, whilst means are provided for

retaining them at any required height. Our illustrations exemplify the plan as adapted for carriages. Fig. 1 is an internal elevation of a carriage door, from which the lining is removed. Fig. 2 is an external elevation, with the panelling removed; and figs. 3, 4, and 5, are separate transverse sections of the door. The inside of the carriage door is furnished with two tassels, one of which is connected to the lowering cord, *A*, whilst the other is attached to the elevating cord. The lowering cord, *A*, is passed under the pulley, *B*, inside the door, and is attached to the end of the short lever, *C*, which is hinged to the bottom of the window-frame, *D*. This lever stands out at an angle when the window is up; but on tightening or drawing the cord, *A*, the lever raises the bottom of the window-frame over the fence-rail, and assumes a perpen-

Fig. 1.

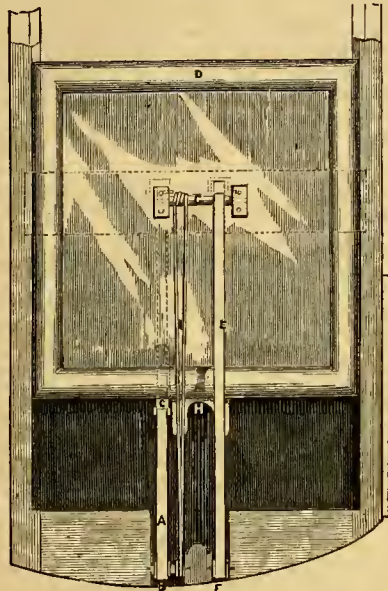

Fig. 2.

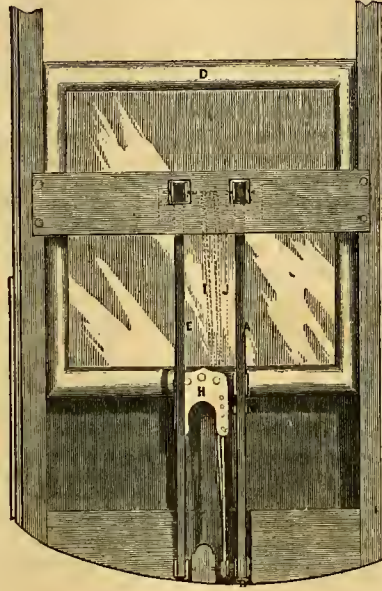

Fig. 3.



Fig. 4.



Fig. 5.



dicular position. The elevating band, *E*, passes down the inside of the door-frame, round the pulley, *F*, and over the roller, *G*, whence it proceeds downwards to the bottom of the window, where it is secured to a metal plate, *H*. The frictional arrangement for retaining the window stationary consists of an endless cord, *I*, of catgut, or other strong material, and is attached to the metal plate, *H*, on the bottom of the window-frame, having been previously passed two or three times round the roller, *G*, for the purpose of increasing the drag or friction. An india-rubber hand, *J*, is attached to the bottom of the window-frame. It is passed over the roller, *G*, and is finally secured to the inside of the door panels. This hand is for the purpose of counterbalancing the weight of the window, and facilitating its elevation.

The contrivance is a very great convenience, which will be appreciated by none more than those who indulge in long journeys in railway carriages. It is the property of, and is now being introduced by, Messrs. Pearce & Countze, the eminent carriage-builders of Long Acre.

screw, *I*, is contained inside the barrel, *C*, and it has a claw, *J*, forged on its lower extremity. The actuating nut, *K*, of this screw is formed in one piece with the bevil-wheel, *L*, and works freely in the upper portion of the barrel, *C*, which has a collar at *M* forged upon it, to support the

TRAVERSING SCREW-JACKS.

G. ENGLAND, *Hatcham Iron-Works, New Cross, London.*—Patent dated May 7, 1853.

This is an improvement upon the well-known and useful "traversing screw-jack," made by Messrs. England for many years back, and now in such general use for all railway purposes. In the new plan, the elevating screw is actuated by combined bevil and spur gearing, very effectively arranged for obtaining convenient changes in the actuating motion.

Fig. 1 is a sectional elevation of the jack, and fig. 2 is a corresponding plan. The wrought-iron bed plate, *A*, of the apparatus has an elevated portion, *B*, formed upon it, and upon this the barrel, *C*, is secured to the horizontal sliding brass, *D*, by the angle iron, *E*, which is riveted to it. The sliding brass, *D*, has two projecting lugs, *F*, formed upon its under side, acting as traversing nuts for the horizontal screw, *G*, which is forged with square ends, *H*, for the reception of a ratchet-handle. This screw rests in the ends of the raised portion, *B*, of the bed plate, and gives the requisite horizontal traverse to the body of the jack. The elevating

Fig. 1.

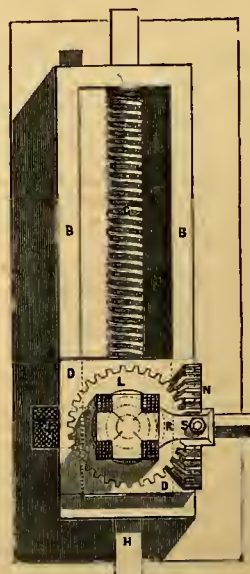
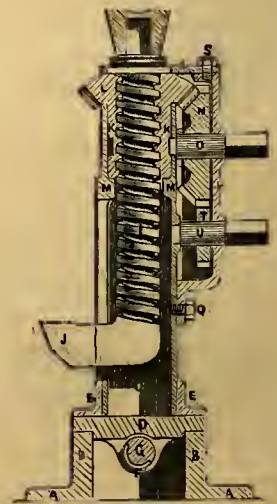

Fig. 2.



nut. The horizontal bevil-wheel, *L*, is actuated by the compound bevil and spur wheel, *N*; the arbor or spindle, *O*, of which works in the wrought-iron bracket, *E*, screwed at *Q* to the side of the barrel, *C*, its upper portion

being supported by the piece, *n*, to which it is bolted at *s*, and which is fitted loosely over the collar of the elevating screw, *r*. The inner end of the arbor works in the side of the barrel, and projects into a groove in the nut, *κ*, thereby holding it in its place. The wheel, *x*, is driven by a spur pinion, *τ*, the arbor, *u*, of which works in the bracket, *p*, and in a boss on the side of the barrel, *c*. The horizontal traversing motion is given by a ratchet-handle, as before described, which is fitted on to one of the square ends of the screw, *g*. When a powerful lift is required, an actuating handle is fitted to the square end of the arbor, *u*, the motion being transmitted from the pinion, *τ*, through the compound bevil and spur wheel, *n*, and thence to the bevil wheel and nut, *l* and *κ*. Should a quick motion be required, the handle is fixed to the arbor of the compound wheel, *n*, when the speed will be increased in proportion to the difference between the diameters of the wheel, *n*, and pinion, *τ*.

SELF-ACTING SAFETY-VALVE.

G. HUMPHREY, Brighton.—Patent dated April 8, 1853.

This is a most ingenious modification of the common lever or steel-yard safety-valve, for the purpose of preventing accidents from overloading, by nullifying the effect of any additional weight or pressure beyond the proper working arrangement which may be applied to the lever. This is accomplished by the slight addition of a helical spring to the short arm of the lever, as shown in the annexed section of a valve,

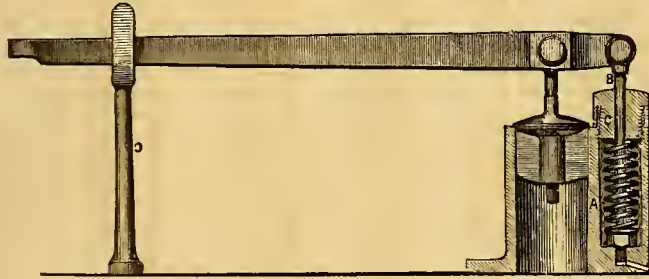

where *a* is the spring-case, cast in one piece with the valve seat. The helix contained in this case is passed upon a short pendant link, *b*, hinged to the lever above, the lower end of the coil abutting against a nut screwed upon the link end. A nut, *c*, is fitted to the top of the spring-case, for the adjustment of the spring pressure, a collar being fitted beneath the head of this nut, to prevent the latter from being screwed too hard down, or beyond a certain determined point. At *d* is a prop for the longer arm of the lever. The reaction of the spring thus measures the holding-down force of the valve, irrespective of any interference with the lever action. And if the lever is too heavily loaded on its longer arm, the prop, *d*, acts as a supporting fulcrum, and relieves the valve of all the additional pressure.

REVIEWS OF NEW BOOKS.

INDUSTRIAL DRAWING: Comprising the Description and Uses of Drawing Instruments, the Construction of Plane Figures, the Projections and Sections of Geometrical Solids; Architectural Elements, Mechanism, and Topographical Drawing; with Remarks on the Method of Teaching the Subject. For the use of Academies and Common Schools. By D. H. Mahan, LL.D., Professor of Civil Engineering, &c. &c., in the United States' Military Academy. 20 Plates. New York: John Wiley. 1852. Pp. 156.

The want of a comprehensive treatise on mechanical drawing, which, on our side of the water, has made itself heard, and found a supply in the "Practical Draughtsman's Book of Industrial Design,"* and similar works, has likewise been felt by our transatlantic brethren; and we have before us good proof that they are not much, if at all, behind us in the promptitude and efficacy of the relief provided. An idea of the general character of the work cannot be better conveyed than in the author's own words:—

"There is no person, whatever his profession, but at times has need of drawing, as an auxiliary, to render his ideas perfectly intelligible to others. The necessity of this art to the engineer, carpenter, mason, and mechanic, is too obvious to be dwelt upon. Without its aid, they would be entirely unable to conceive understandingly any plan of a

structure in any degree of a complex character, and still less to carry it satisfactorily into execution. Industrial drawing, as the term is understood in this work, will supply this want. It is, in fact, to the artisan of every class, what writing is to all, except in being more comprehensive and succinct, rendering the forms and dimensions of the most complex objects at once to the eye within a narrow space, and that by a short-hand process, in which no detail, however minute, is omitted; an operation which, if it could be performed at all by an ordinary written description, could hardly fail of being confused, and would certainly, in such cases, demand great labour on the part of the writer, and be an equally tedious one to the reader.

"The work, with the exception of the chapter on topography, has been confined to instrumental drawing; and it will be seen that it supposes, on the part of the student, a certain acquaintance with technical scientific language or definitions. The omission, for the most part, of these definitions was rendered necessary, to bring the cost of the work within the range of that of ordinary school-books, in order that its chief object, as a work of elementary instruction, might not be defeated. Any want of acquaintance with such terms can be readily supplied by an intelligent teacher, as occasion may require, by oral explanations; or still better, by large diagrams of the plane figures referred to, and models of the other objects placed before the pupil during the lesson.

"The best method of conveying instruction on this subject, the object of which is not to deal with abstract reasoning on which it is based, but to furnish the most simple means of mastering its difficulties, and applying it to the many practical purposes of which it is susceptible, is the oral."

It will thus be seen that the work is especially intended for oral instruction, which is undoubtedly the most efficient and rapid, when aided by private study on the part of the pupil. Viewed in this light, the work is all-sufficient; and beyond this it will be exceedingly useful to the practical draughtsman, for the problems and applications discussed are exceedingly numerous; and an occasional reference to the direct method of constructing this or that figure, which may present more than ordinary difficulties, will save him a great deal of time, which might otherwise be lost in wading through the suggestions of a dim and blundering memory.

The plates are printed on an extra size of paper, so as, when unfolded, to lie quite clear of the letterpress pages—a great convenience for reference, and one which we are sorry now so seldom to see. It is a point in which modern publishers would do well more frequently to copy their predecessors of the last century.

A RUDIMENTARY TREATISE ON FUEL, PARTICULARLY WITH REFERENCE TO REVERBERATORY FURNACES. By T. Synes Prideaux. London: Weale. 1853. Pp. 128.

The subject, on which the above title promises useful information, is of undoubted importance; for, as the author remarks in the introduction, "the question of consumption of firing lies at the root of the cost of production." It was therefore with considerable interest we took up the book, and commenced exploring its pages. We expected to find a full and circumstantial account of the present theory and practice in the employment of fuel, for the production of heat, in the various industrial processes in which its agency is needed—such an account, in fact, as might be looked for in a rudimentary treatise. Our readers will judge that we were somewhat disappointed, when we tell them that we found the work to be entirely devoted to the discussion and recommendation of new systems of constructing and working furnaces, invented by the author, and as yet not generally, if at all, put in practice. We would not deny any man the right of writing a book to recommend his inventions to the public; nor do we wish it to be inferred that the systems here recommended are without merit, for the facts and reasoning here put forth with some ability plead the contrary; but we do protest against calling such a work a Rudimentary Treatise. This misappellation may be assumed to wrong both author and publisher; for who, desirous of learning the particulars of Mr. Prideaux's new systems, will think of looking for them in rudimentary treatises; or who, in search of general rudimentary knowledge, will not feel disappointed with such an example of the series, and be led, in consequence, to question the utility of applying at the same source for similar information on other subjects?

Setting aside the fault alluded to, the book is well worthy the perusal of all fuel consumers. The author shows a thorough acquaintance with his subject, and brings to bear upon it what it has hitherto, for the most part, wanted—a clear insight into the chemical laws, relations, and conditions concerned.

Suggestions of improvement, called forth by an investigation and examination such as the subject has received from Mr. Prideaux, demand serious attention.

* See page 26, Vol. VI., *Practical Mechanic's Journal*.

"It is unquestionable," as our author remarks, "that the manufacture of iron has hitherto borrowed less from science, and is in a ruder and more barbarous state, than our other manufactures, and it is equally unquestionable, that such a state of things will not be allowed to continue. Why are 'refinements and niceties' introduced, carried out, and adopted, in other departments of production? Is it to gratify a longing for the ideal in those engaged in them, or as a question of *£. s. d.*? In short, when we view the keen spirit of enterprise and competition which leads manufacturers in other departments to seek to increase their profits, by every expedient for cheapening production, which the improved chemical and mechanical knowledge of the day places within their reach, it is puerile to suppose that the iron trade is to prove an isolated exception to a general rule, and remain exempted from the operation of the same principles. The shadow will not tarry on the dial for the sluggard; and those who will not read the signs of the times, but choose to persist in working by the rule of thumb, will be taught its insufficiency by their balance sheets."

THE DECIMAL COINAGE: A Letter to the Right Hon. the Chancellor of the Exchequer, advocating, as a preliminary step, the issue of a Five-farthing Piece. By A. Millward, Esq. Pp. 48. London: G. Bell. 1853.

The author, as a traveller, has had "the advantage, not only of knowing, by experience, the relative convenience of different currencies, but also of judging how a new system may be introduced with the least amount of annoyance; because he has been in the habit of passing from the currency of one country to that of another, and has thus been made to feel where the shoe pinches;" and he advocates, as the first definite step, the issue of a "five-farthing" piece, in such quantity as to give one of these new coins to every two or three existing halfpence. The pages contain a very clear, practical exposition of the case, the details of which our interested readers will best understand from the work itself.

POTATOES GROWN FROM PEELS. Pp. 60. Cork: Bradford & Co.

This is a reprint of a series of interesting letters, from the active pen of C. B. Newenham, Esq., of Dundanion Castle, Cork, originally published in the *Cork Constitution*. It is, perhaps, enough for us to state, that the author makes out his case most convincingly. Were this not quite so clear from the pages before us, we could yet bear effective testimony on the subject—from our having both seen the potatoes growing in the Dundanion Castle gardens, and discussed the cooked root at the author's table.

TO THE HONORABLE THE LORD PROVOST, THE MAGISTRATES AND TOWN COUNCIL, AND TO THE WATER-RATE PAYERS OF THE CITY OF GLASGOW, THE RESPECTFUL REMONSTRANCE OF LEWIS D. B. GORDON, CIVIL ENGINEER, AGAINST THEIR ADOPTING MR. BATEMAN'S PLAN FOR CARRYING OUT THE LOCH KATRINE WATER SCHEME. Pp. 16. 1853.

In 1845, the author, in conjunction with Mr. L. Hill, discovered that Loch Katrine was "the only available source of supply of pure water, in unlimited quantity, within reach of Glasgow, commercially speaking." The scheme Mr. Gordon then proposed, and now again advocates, assumes the possibility of bringing this unlimited supply along an aqueduct to a reservoir close to Glasgow, at an expense of £247,000, against Mr. Bateman's estimate of £487,000, for conducting the water through iron pipes to a reservoir at Milngavie, some seven miles from the city. Hence the appearance of this pamphlet, as a "remonstrance" against what its author conceives to be a needless outlay of capital.

PROPOSED LONDON RAILWAY, to afford Direct Railway Communication between the City and Westminster, and all the Western Suburbs. By P. M. Parsons, C.E. London: W. S. Johnson. Pp. 29. Lithographic Plates.

This pamphlet recommends itself by the earnestness and straightforwardness with which the subject is discussed, and by the evidences of laborious investigation to which the author has submitted the project in all its bearings. The object of Mr. Parsons's proposed plan is, to furnish "a connecting link to unite the termini of the various metropolitan railways, and at the same time afford them access to the heart of London, which has long been an admitted desideratum, and a line that would effect this, and at the same time give a like accommodation to the principal suburbs, would be of still greater importance."

The proposed railway possesses many advantages, and we regret that

our space will not permit us to transfer the more interesting portions of the pamphlet to our pages. The estimated cost of the line is something short of three millions sterling, and on this capital a revenue of nearly 10 per cent. is considered certain. There are, doubtless, many things to be said both for and against the plan; but in this it is not unlike all plans with similar objects, and the revenue promised ought at least to invite inquiry into its merits

THE FIRST PRINCIPLES OF PERSPECTIVE, EXPLAINED THEORETICALLY AND PRACTICALLY, in a Course of Easy Studies, designed for Self-Tuition and the use of Teachers. By Felix Duffin. London: E. & F. N. Spon. 1853. Pp. 32. Lithographic Plates.

Mr. Duffin has added another to the multitudinous treatises on perspective, but we doubt we can hardly say that he has thereby increased our knowledge on the subject. Neither do we find that he has improved on previous authors, by a better development of the science, or a more convenient arrangement of his materials. He has condensed, without simplifying. There are almost as many systems of drawing in perspective, as there are teachers of it, each with peculiarities which habitual use has made the artist view as simpler or more expedient than other methods. Mr. Duffin gives a method for finding the vanishing points in a perspective picture, consisting in defining their distances from the centre of the picture by means of tangents. He draws a semicircle, the radius of which is equal to the distance of the picture from the eye, and sets off a line at the ends of the diameter, and at right angles to it, and on this line is to be marked off the tangents that are required. Supposing it is required to find the vanishing point of a horizontal line, lying at an angle of 30° with the plane of the picture, the tangent of the complement of the angle of 30° , that is, the tangent of 60° , must be taken as the distance of the vanishing point, from the centre of the picture on the horizontal line. Now, why not adopt the more obvious and simpler plan of drawing a tangent to the semicircle parallel to the diameter, so that, by drawing a line from the centre of the circle at the original angle, it will at once cut off the necessary length on the tangent? Mr. Duffin's system will assuredly confuse the student by the number of processes necessary, and by the obvious multiplication of lines and angles. As to the second plan, its connection with the principles are direct and obvious, but it is simply the old well-known method with the addition of a semicircle, which is not of the slightest use.

In his introduction, Mr. Duffin says, "the plea of expediency in reference to the representation of objects, as they are not or cannot appear, is evidently an absurdity." This cannot refer to drawing incorrectly in perspective, for no plea can be urged for doing a thing incorrectly, and we presume that "geometrical projections," or what are more commonly known as "mechanical drawings" are here alluded to. If so, Mr. Duffin betrays some looseness of conception as to the use of such drawings. Mechanical drawings represent things as they are, but do not profess to show them as they appear; they are not generally intended for pictures, but as records of the measurements of the details of machinery, for which purpose they are drawn to a scale. Thus, their office is totally distinct from that of perspectives, and one which the latter cannot fulfil.

Mr. Duffin is his own illustrative artist, but we regret to say that the work gains nothing in consequence; for whilst the letterpress, paper, and general getting-up are unexceptionable, the plates are what an ordinary practical lithographer would hesitate to send forth to the public.

A WORD IN SEASON; or, How to Grow Wheat with Profit. Addressed to the Stout British Farmer. Tenth Edition. 8vo. Pp. 52. London: Ridgway. 1852.

This little pamphlet, which has run through so many editions, is the now acknowledged performance of the Rev. S. Smith, vicar of Lois Weedon, Northamptonshire, an ardent agriculturist, a hearty friend to the labourer, and a disciple of Jethro Tull. In his latter character, he first gives us a "comparative estimate of the practice of Jethro Tull on the growth of wheat:—"

"The principle of Tull, in his tillage for wheat, was to pulverize the soil effectually to the bottom of the staple, in order that every particle of the mould might be impregnated with the fertilizing substances of the atmosphere, whatever they were; and that the roots of the plant, at the same time, might be enabled with ease to permeate the loosened earth, and so take up the food thus placed within their reach.

"To attain his object, he divided his field by broad and deep furrows—as deep, that is, as the staple would permit, and no deeper—into lands about six feet wide. In the centre of each land he drilled his seed in two rows about ten inches apart, thus leaving an interval of about five feet between each double row. Then when the plant was up, came a very nice and difficult operation. After closing up the furrow, he ploughed the whole interval, with the exception of six or eight inches, for a winter fallow, taking the last slice within three or four inches of the wheat, and leaving that standing on a ridge about eight

teen inches wide, with a deep furrow on each side. Thus it remained during winter. At spring another equally nice and difficult operation succeeded. He cast back the soil, thus fertilized by exposure, against the tender wheat, and restored the broad furrow in the centre of the interval. Then, during summer, as often as the nature and state of the soil required it, he horse-hoed, or rather ploughed it away from the wheat, and then back to it again, retiring farther and farther from the spreading roots as the season advanced, and operating for the last time after the wheat had just gone out of flower.

"The process succeeded to admiration. The well-stirred soil had become impregnated with the elements of fertility. The roots had been enabled to take up their nourishment. The straw exposed to the sun and air, hardened and stood well up, except in very peculiar seasons. The ears became unusually bulky, the grain large. And Tull calculated that thus, without manure, on the same acre of land, he gained, year after year, for several years, a profit much larger than that of farmers in the common mode of farming."

But Tull's system passed away. Was there, then, a flaw in this brilliant theory? Mr. Smith replies that all was right as concerned root crops; but in corn all was wrong. There were too many practical difficulties of culture—a too great nicety of execution was required; and here our author steps in with his remedy for the defective practice of so admirable a theory. He says:—

"I divide my field into lands five feet wide. In the centre of each land I drop or drill my seed in triple rows one foot apart, thus leaving a fallow interval of three feet between each triple row. When the plant is up, I trench the intervals with the fork, easily taking my spits about three inches from the wheat, and at spring and during summer I clean them with the blades of the sharp-cutting horse-hoe, and keep them open with the tines of the sifter. Every year, in short, I trench and cultivate two and a half feet out of the five for the succeeding crop, and leave the other two and a half for that which is growing.

"One moiety of each acre is thus in wheat, and the other moiety fallow; and the average yield of that half acre is 34 bushels, grown without difficulty or danger in the execution, and surpassing the average yield of a whole acre on the common plan.

"It will here be seen at a glance how I differ from Tull in practice—how the fork takes the place of the plough, and does better work in a narrower compass—how the fallow is reduced from four-fifths of the land to only one-half—and how, in consequence, the produce is more than doubled at once."

We cannot follow the author through the rest of his deductions, which are set forth in terms of golden promise. The scientific agriculturist would better appreciate a visit to Lois Weedon, where he may see what spade labour has done on a moderately small scale, and inspect a reaper specially contrived for this system of wheat growing.

MORAL SANATORY ECONOMY.—By Henry McCormac, M.D. Pp. 150. 8vo. London: Longmans. 1853.

ON THE CONNEXION OF ATMOSPHERIC IMPURITY WITH DISEASE. Same Author. Pp. 8. 8vo. Belfast: Greer. 1852.

Dr. McCormac's force, eloquence, persevering research, devotion to his subject—and that subject a vitally serious one—ought, and must, indeed, induce our more thoughtful readers to bestow some consideration on these pages. Every line in them is full of meaning, and deserves to be read and weighed with as much care as the author has evidently bestowed in writing it. Each of the twelve chapters—"Female degradation, employment, education, household culture, criminal management, physical training, clothing, food, drink, air, drainage, and prevention of disease"—into which the dissertation on "Moral Sanatory Economy" is divided—furnishes, in its individual self, a weighty study. To this we can only incite and direct the reader—we cannot accompany his footsteps. We shall content ourselves with quoting the following passage from the second of the works which we have named:—

"Short of atmospheric purity, consumption is not less frequent in warm climates than in cold. Intercurrent pneumonia and pleuritis will be less frequent, not so phthisis. Those warm climates in which consumption is really less frequent than in cold, derive the comparative immunity simply from the people being forced by the great heats to live more in an unpolluted atmosphere. If the inhabitants of Great Britain and Ireland would but consent, day and night, to live in a pure untainted atmosphere, it would put a total close to the ravages of consumption. It is not sending people to warm climates that avers or cures consumption. It is sending them to pure air, in so far as they are so sent, that does so, and this only. To confine consumptive persons in close, heated apartments, is but to hasten the ravages of their disease. On the contrary, they should live as much as possible in the open air. Let us keep the consumptive in pure, fresh air, and we shall at once realize a Pan, a Nice, a Madeira, better than any Pan, or Nice, or Madeira, without fresh air. And better still, let us live in a pure, unadulterated atmosphere, or in air equally pure as the open, unadulterated atmosphere, and we shall have no consumption whatever! It is quite illusory to think of curing the consumptive by means of food, or even medicine, without the amplest access to the free, fresh air. An ounce of oxygen is worth tons of fish-oil or iodine, or any amount of wire air-sieves for mouth or nostril, without oxygen!

"The dirt and sordes amid which the poor so habitually live, bespeak sufficient condemnation. The senses take alarm, and sympathy and horror are in unison with our best judgments. These monitors, however, are at fault in the dwellings of the rich. There, perfumes regale the nostrils, rich hangings solace the eye. Nevertheless, it is undoubted that atmospheric impurity in the dwellings of the rich, however it may fail to outride itself on the senses, is only inferior in virulence and destructiveness to what it proves in the dwellings of the poor. That it is so, let the dreary catalogue of persons of all classes, yearly swept away in these islands by consumption, declare! The remedy for this defective state of things is the improved condition of our domestic atmosphere. In a treatise, styled "Moral Sanatory Economy," I have pointed out various means of securing this important consummation. I would here, however, signalise an error of some importance—namely, that ventilation does not signify mere draughts. People hate draughts, and justly. There should be ventilation; but as regards cold-air ventilation, and warm-air ventilation alike, there should be no appreciable—certainly no appreciably injurious or disagreeable draughts. It is one of the very great advantages of French casements, that they open completely at pleasure, so as to yield a perfect mass of fresh air, irrespective of draughts. They permit windows also to be cleaned from the inside without risk, and at the same time insure copious and most desirable supplies of light. It would be very easy, however, to make our common casements, which now only open one-half, open completely, and draw down as well. In other respects, coupled with perfect purity of the domestic atmosphere, there should be warm fires, warm clothing, and the amplest supplies, during the cold season, of masses of air heated to a moderate temperature."

CORRESPONDENCE.

SELF-ACTING LUBRICATOR.

The accompanying sketch represents my automatic lubricator in vertical section. The cup, A, has a spindle passing through it, on one end of which spindle is a pendulum, C, with its cylindrical socket, D, in section, to show the spiral riband or clutch, E, which it embraces.

The spiral riband or clutch is made truly cylindrical to fit the spindle, and it rests without being fixed on the washer, F, on the outer end of the spindle. The inner end of the clutch, E, is fastened to the inner end of the socket, D, as shown at G. Within the cup there is another spiral riband or clutch, H, which is fastened to the inside of the cup, at J. Within the cup the spindle carries a roller and bucket-wheel, K, cast in one piece, and fastened to the spindle by a pin passed transversely through the boss; at L is an oil cup or bucket, the supporting link of which is fastened to the bucket-wheel by a screw.

To understand the action of the apparatus, let us suppose these engines to be in motion. The pendulum, C, is then caused to oscillate, and, whilst receding, the clutch, E, grasps the spindle tight, and by its friction carries the spindle round with it. When the pendulum returns, the clutch, H, grasps the spindle and keeps it from returning, whilst the clutch, E, relaxes and slips easily over the spindle. After a few vibrations, the bucket, L, comes round, and empties itself over the roller, K, and thence the oil flows down the tube, M, to the journal or surface to be lubricated.

I have had this lubricator working all this "navigation," on board the Russian Imperial Post Steam-Ship *Vladimer*, and I find it works much better than the rest of our cups, which are made with the ratchet-wheel, and it does not require one-fourth of the repairs.

R. S. THOMSON.

Cronstadt, Russia, November, 1853.

CAPSICUM GRINDING.

Can any of your readers inform me whether there is any machine in existence for grinding *capsicum* into red pepper? In some places, a pestle and open mortar are used, but the fine dust arising during the process of trituration is highly injurious to the eyes.

A. B. C.

PLAITING AND BRAIDING MACHINE.

No doubt you can understand the feeling of disappointment which an inventor must experience, when he finds that a long-cherished scheme has been developed at an earlier period by other parties. Such, sir, is the case as regards Messrs. Booth's braiding machine, described in the December number of the *Practical Mechanic's Journal*, in as far as the tubular spindles are concerned. Braiding machines with tubular spindles have been worked here for several years; and a machine of precisely the same form as that of Messrs. Booth—namely, a 9-bobbins russia—has been regularly worked, but on a lighter material—principally silk, with a vulcanized india-rubber core. Indeed, the machine contributed by myself to the Dublin Exhibition,* although making a different braid, was furnished with hollow spindles.

I make these remarks with no other intention than the removal of an erroneous impression, that braiding machinery, although yet in its infancy, has only just arrived at the "hollow spindle" period of its growth.

WM. SERVICE.

Rutland Terrace, Hornsey Road, London,
December, 1853.

* Page 153, *Practical Mechanic's Journal* for October last.

REFLECTING FOG BELLS FOR STEAMERS.

I beg to suggest, through the medium of the *Practical Mechanic's Journal*, the following means of preventing collisions at sea. It is well known, that if a sounding body be placed in the focus of a parabola formed of any material capable of reflecting sound, the issuing rays will proceed in a direction parallel to the axis of the parabola. Now, it is quite a common practice, on board steamers, to ring bells, so as to inform other vessels in the neighbourhood of what is near them. But it is often the case that a ship in the very path of a steamer, and hearing the fog bell, is unable to clear a steamer, from ignorance of the course steered by the steamer.

To remedy this, I propose to place a large parabolic reflector athwart ship, so as to act in the direction of the keel line, and just abaft the fog bell. When the bell is struck under these circumstances, the reflected vibrations will proceed right ahead, so as to give the best possible notice of the steamer's approach; and this plan, it must be remembered, will cause the bell to be heard at a greater distance than at present.

JAMES MEIKLE.

Strathaven, December, 1853.

PROCEEDINGS OF SCIENTIFIC SOCIETIES.

INSTITUTION OF CIVIL ENGINEERS.

NOVEMBER 15, 23, AND 29, 1853.

The discussion upon the paper on "Ocean Steamers," by Mr. Andrew Henderson, Assoc. C.E., was commenced by quoting from an article in the *Edinburgh Journal*, by Professor Tenant, of St. Andrew's, the dimensions of some of the large ships built by the ancients; whence it appeared, that a ship constructed by Ptolemæus Philopator, was 420 feet long, 56 feet broad, and 72 feet high from the keel to the prow; and was manned by four thousand rowers, four hundred servants, and two thousand eight hundred and twenty marine.

Hiero, King of Syracuse, caused to be built, by Archias, the Corinthian shipwright, under the supervision of Archimedes, a vessel which appeared to have been armed for war, and sumptuously fitted for a pleasure yacht, and yet was ultimately used to carry corn; the dimensions were not recorded, but as there were twenty banks of oars and three masts, the timber for the mainmast, after being in vain sought for in Italy, being brought from England, and the cargo was sixty thousand measures of corn, besides vast quantities of provisions, &c., for the crew, the dimensions must have exceeded those of any ships of the present day: indeed, Hiero, finding that none of the surrounding harbours sufficed to receive his leviathan, loaded it with corn, and presented the vessel, with its cargo, to Ptolemy, king of Egypt; and on arriving at Alexandria, it was hauled ashore, and nothing more was recorded respecting it.

Taking these dimensions as the basis for calculating the tonnage by the old law, or builders' measurement, and, in accordance with the report of the late Tonnage Committee, taking the average tonnage of ships as amounting to twenty-seven hundredths of the external bulk, measured to the medium height of the upper deck, the burthen and cubic content of these vessels would be:—

	Tonnage.	External Bulk.
Ptolemæus Philopator's ship =	6,445 tons,	830,700 cubic feet.
Noah's ark.....	11,905 ...	1,580,000 do.

And contrasted with these few modern ships:—

Great Western.....	= 1,242 ...	161,100 do.
Great Britain.....	= 3,445 ...	446,570 do.
Arctic (American packet)...	= 2,745 ...	356,333 do.
Himalaya	= 3,528 ...	457,332 do.

And, calculating by the same rules, taking the dimensions given in the prospectus of the Eastern Steam Navigation Company, their

Proposed iron ship..... = 22,942 tons, 2,973,593 cubic feet.

It was, however, stated that this vessel was intended to be 10,000 tons register, which might be correct, if it was built on the cellular system, and was measured internally by the present law. This latter example was only given, to demonstrate the advantage of adopting the proposed system, of using the mean of external and internal measurement, as the basis of the calculation of the tonnage, and of recording all the dimensions, and the scale of burthen on the certificate of survey.

The first point then considered, was the effect of heavy seas upon vessels of 400 to 600 feet long. The waves of the Atlantic were stated, by some captains of American "Liners," to attain an elevation of about 20 feet, with a length of 160 feet, and a velocity of 25 to 30 miles per hour.

Dr. Scoresby, in his paper on "Atlantic Waves," gave about the same mean elevation for the waves, in rather a hard gale ahead; on one occasion, with a hard gale and heavy squalls, some few waves attained a height of 43 feet, with a length of nearly 600 feet, and a velocity exceeding 30 miles an hour. Other authorities assumed even more than those heights and distances.

The amount of strength to resist the impact of such waves, must vary with the length and size of a ship, and the materials of which it was constructed; and as the experience of the Britannia Bridge showed, that a weight of 460 tons, at a velocity of 30 miles per hour, could be borne by a cellular tube of 460 feet span, it

was demonstrated that, by the use of iron, almost any amount of strength could be given to a vessel; and as stability could be imparted by proper proportions, efficient vessels could be built of any dimensions, as had been exemplified by the *Great Britain*, which, after remaining ashore on rocks for several months, had been got off without serious injury. There were, however, objections to the use of iron alone for vessels; therefore many other systems had been essayed, such as all English oak, pine of large scantling, three thicknesses of diagonal planking, and iron framing with stout planking—this last combination, with the addition of fore and aft ties and water-tight bulkheads, was advocated for efficiency and economy.

The proportions of about six breadths for the length were insisted upon, and it was noticed that these were given as the dimensions of Noah's ark, as recorded in Holy Writ.

The effect of heavy waves upon vessels of great length was discussed, particularly when in the trough of the sea, and without sufficient "way on" to enable the rudder to act; under such circumstances, it was suggested that there might be a bow rudder, and a propeller so placed as to assist the action of the helm in bringing the vessel round.

The innovations proposed by Mr. Roberts, and illustrated by his models, were examined.

An examination was made of the project for transmitting letters between Holyhead and Dublin, at a speed of 22½ statute miles per hour;—of that for communicating between New York and Liverpool in six days, at an average speed of 22 nautical miles per hour;—and for steaming to Calcutta and back, without re-coaling, traversing a distance of about 25,000 nautical miles, at an average speed of 15 nautical miles per hour; using elaborate calculations and tabulated results, based on the duty performed by H. M. S. *Rattler* with a given power, and under known conditions.

Objections were raised to accepting 7½ knots per hour as the data for the present average rate of speed of ocean steamers; it was urged that such an average must have been derived from the voyages of steamers of old date, and without regard to the later results deduced from the performances of the Cunard and the Collins lines of steamships.

The propriety of taking the *Rattler* as a model steamer was questioned, especially as the data were not given for selecting that vessel, it being argued that the *Rattler* had not performed a series of long voyages, under every variable line of immersion, or under such changes of weather and states of the sea, as to furnish data for such important deductions.

The advantage of increasing the proportion of length to breadth was apparent, if it was admitted that the cargo-bearing capacity of a vessel was thus augmented, without materially affecting her direct resistance through the water; supposing her midship section to remain unaltered. The proper proportion of length to breadth for an efficient ocean steamer was, however, an intricate question. Taking the *Wave Queen* as an example: the length of that vessel had been stated to be thirteen times her beam; now such proportions might answer well for the river Thames, and a great speed might be attained, but such a vessel would, under certain circumstances, be unfit to navigate the British Channel. The same might be said of the American river steamers, which were reported to have attained almost fabulous rates of velocity; but such proportions as theirs, if attempted in ocean steamers, would only induce failure and loss of the vessels in heavy gales in the open ocean.

It was contended, that the statement of a supposed wave pressure of 85,000 tons of water, or even of 40,000 tons, to which it had since been reduced, by a modified estimate, was inadmissible; it would be manifestly impossible for any vessel to withstand such impact from a body of water; and if the position was admitted, it must be evident that any of the ordinary coasting steamers would constantly be liable to a pressure of 1,000 to 1,500 tons, which would suffice to utterly destroy them.

The comparison of the qualities for safe riding, when lying-to, between a line-of-battle ship and a privateer, was not to the point, as the former was encumbered by the enormous weight of her armament, and by her top-hamper; in short, the whole misconception had arisen from confounding the wave of oscillation with that of translation: this was exemplified by the case of a disabled vessel; so long as she remained afloat she was comparatively safe, but as soon as she touched the ground, and the wave of oscillation became one of translation, she was immediately knocked to pieces by the impact of the waves.

Next, as to the proportions of 6 to 1, which had been derived from as ancient a type as Noah's ark;—now, as far as was known, as that construction had not been designed either for sailing or steaming, but only to float with a very large cargo, it afforded no analogy for vessels built for speed, however propelled; and, in fact, modern fast-sailing vessels had abandoned those proportions, which had only been perpetuated by the old tonnage laws, under which merchant vessels were enabled to be constructed to carry enormous cargoes, but they were unable to attain any considerable speed. It was further argued, that as steam propulsion was employed, the analogy became still less apparent; and, as an instance of the advantage of lengthening ships, the case of the vessels belonging to the North of Europe Steam Navigation Company was mentioned. The *City of Norwich*, 183 feet long, 26 feet beam, 471 tons burthen, and 200 H.P., could carry, as cargo, 220 head of cattle, at a speed of 10 knots per hour, but she rolled considerably with a beam sea; whilst the *Tonning*, 222 feet long, 27 feet beam, 734 tons burthen, and 200 H.P., carried 360 head of cattle, at a speed of 12 knots per hour; she was a remarkably easy vessel, and had proved her sea-worthy qualities by coming safely round the coast of Scotland during the late gale in September. Thus, with the same engine power, by merely altering the proportions from 7 to 1 to 8 to 1, nearly 60 per cent. more cargo space was obtained, and 2 knots per hour were gained in speed, with improved sea-going qualities. It must be remarked, also, that the relative

proportions of the *Tonning* were almost identical with those of the proposed iron vessel for the Eastern Steam Navigation Company.

Taking the *Wave Queen* as an extreme case, her length being 213 feet, with 15 feet beam, and proportions of 13 to 1, with a draught of water of only 5 feet, and comparing her performances with those of the *Christiana*—a good vessel, about 170 feet long, and with about the proportion of 6 to 1—it was found, that whilst the latter, in a moderate head-sea, continually shipped the waves, the former, in a similar sea, was perfectly dry. This evidence was given from the personal experience of the speaker.

The *Wave Queen* had since been running between Newhaven and Dieppe, and it was to be expected, indeed it had been predicted, that, from local circumstances connected with the entrance of the harbour at Newhaven, she would meet with some casualty. She was not stranded in consequence of any inefficiency in the power of the rudder; but after a very bad passage across the Channel, in the trough of the sea, which was running very high, she arrived off Newhaven, when there was scarcely depth of water over the bar for her to cross, she touched the ground heavily, and hung by her "heel," a beam sea catching her at the same moment, swung her round, and threw her broadside on the beach, where all the passengers were safely landed. It was a good proof of the strength that could be given to iron ships, that though she was thrown broadside on the shore by the waves of translation, she was safely got off and brought round to the Thames without material damage.

As to the elaborate calculations entered into, with respect to the three great navigation projects;—before admitting the correctness of those results, it must be clearly understood that the *Rattler*, which had been used as the type, was built during the most depressed period (scientifically) of construction in H. M. Dockyard. Her dimensions were 176 feet long by 32 feet 6 inches beam—a proportion of about 5½ to 1; and from what had been published, it must be evident that she had just performed what might have been anticipated from such proportions. At the time of the construction of the engines of the *Rattler*, marine engineers had scarcely adopted, and rarely practised, the use of the steam at a certain amount of pressure and expanding in the cylinder, whereby such a vast economy in the consumption of fuel was now realized. Now, if the calculations of fuel required for long voyages were based upon the old scale of consumption, instead of the present rate, which, in good ships, did not exceed 3½ lbs. per *real* H.P., the deductions from the calculations must be still more unacceptable.

It was then contended, that all arguments based upon calculations of the speed and other qualities of such a type must be utterly fallacious. It had been shown what increase of speed and of carrying qualities had been produced by lengthening the *Tonning*, without increasing her power, and, by analogy, it was only reasonable to presume, that if the proportions of the *Rattler* had been altered from 5½ to 1, to nearly 8 to 1, there would have been a still more striking amelioration, and she would have been a more trustworthy type for the calculations and arguments as to the practicability of constructing and of commercially working large ships. It was argued, that with all these, and many other examples to the contrary, it was evidently incorrect to attempt to assume that 6 to 1 was the best proportion of vessels of any kind.

The advantages of employing a smaller number of large ships, rather than a greater number of small ships, for a given trade, especially for long voyages, was beginning to be generally admitted by shipowners. A return was published in the *Times* of November 22d, 1853, copied from the *Liverpool Albion* of November 21st, which presented the results of that experience in a remarkable form.

"The following table shows the average number of days occupied on the passage by the vessels of different tonnage, ranging from 200 tons upwards, despatched from Liverpool to Australia, in the years 1852 and 1853:—

	1852.	1853.
	Average number of days.	Average number of days.
Under 200 tons.....	137	133
From 200 to 300 tons.....	122	122
— 300 to 400 —.....	123	113
— 400 to 500 —.....	118	112
— 500 to 600 —.....	113	112
— 600 to 700 —.....	107	103
— 700 to 800 —.....	108	101
— 800 to 900 —.....	103	100
— 900 to 1000 —.....	102	95
— 1000 to 1200 —.....	96	91
— 1200 and upwards.....	91	90

"From the above table it will be seen, that in almost every instance the average is in favour of the largest ships, the 600-ton ships having an advantage of 24 days on the average in 1852, over the 200-ton ships, and the 1,200-ton ships having an advantage of 22 days over the 600-ton ships. In 1853, also, it will be seen that the results are much the same."

It must be evident, that for each length of voyage and description of trade, there was a particular size of vessel that would be most suitable; and, indeed, as in most other engineering works, the circumstances of the traffic would of themselves mainly determine the proportions of the structure. Take, for example, the

trade between England and America, as originally opened by the *Great Western*; that vessel, at first designed, although much the largest ship of her day, was of the smallest size by which such a trade could be conducted; and her length was actually increased, during her construction, to a point then generally considered dangerous.

Since that period, all vessels on that station had been successively augmented in dimensions as the trade increased; but even those vessels were too small for the Australian voyage of 25,000 miles, and the necessity of increasing the length was shown, by calculating how much coal would require to be carried beyond that needed for an American voyage, in order to do the Australian or the Indian voyage equally well. Such calculation demonstrated, that a vessel similar to the *Great Western* would require to be lengthened to 520 feet to accomplish that voyage. This argument showed, that the conditions of the case compelled the adoption of vessels of extraordinary length for steam voyages of extraordinary distances.

Then, as to the commercial question: the merchants engaged in the Indian and Australian trade had calculated, from the data afforded by their own business, what amount of freight and passengers would require accommodation, and it was found that the quantity was greater than could be received by the ship just calculated. The dimensions, therefore, required to be enlarged, to meet the demand of the existing trade. Thus the traffic itself did actually fix the dimensions of the proposed large class of vessels.

As to the mechanical strength of such vessels, there was no difference of opinion on that point among engineers, provided the structure was of iron. Ships of wood, on the contrary, were limited in size by the nature of the material, which was *grown*, and not *manufactured*, and therefore the produce was of limited size; whereas plates of iron could, on the other hand, be rolled of any required dimensions. It must be observed, also, that the strength of wood across the fibre was so small, that two planks could not be so united as to be equally strong in all directions; whilst two plates of iron, riveted together, were of nearly uniform strength.

Further, as to the resistance of large vessels to waves; it was evident that the waves of the Atlantic, being of the same size, whether the vessel was small or large, their proportional magnitude would be decreased as the size of the vessel was increased, so that the large ship, in a gale, would merely encounter waves of the same proportional size as a ship of half the dimensions, in half a gale; and it should be remarked, that the largest ships which had been proposed were only double the lineal dimensions of existing vessels.

As to the impact of waves upon ships, it should be remembered that a vessel riding on a wave became, virtually, a part of that wave, and moved along with it, as the mass of water, displaced by its bulk, had previously moved. The large Atlantic waves, observed by Dr. Scoresby, did not strike the ship, but made her rise and fall in a gentle oscillation, each of which lasted 16 seconds, a period of too long duration to admit of any approximation to violent collision between bodies.

It was only the small wind waves, or crests, which moved at a different velocity from that of the ship, and the proposed vessels were so much higher out of the water than the observed altitude of these waves, that the decks would probably never be more than wetted by the spray.

It was explained that H. M. S. *Rattler* had been assumed as a type, or good example, of locomotive efficiency, because the formula $\frac{(V \sqrt[3]{D^2})}{\text{Indicated H.P.}}$ gave the highest result of any steamer examined by that rule. It would be seen that the formula merely embraced the relations of velocity, displacement, and working power.

It was stated that a vessel which, from any fault of construction, or from imperfect steering power, was liable to fall off into the trough of the sea, would, in that position, be liable to fearful accidents; and instances were cited of two vessels, of 800 tons and 1,200 tons respectively, being struck by waves which had carried away all the upper works, and swept the decks clear. These practical facts were given to show that the gentle oscillation of heavy waves must be received with some qualification. In answer to this, it was explained, that in a storm there were generally two sets of waves, the long low oscillating wave, and the smaller waves, which were much shorter, rising under the action of the wind. It was these short waves which struck the smaller vessels with so much force, when they got on the crest of a large one; but the deck of a very large ship would be too high for such wind waves to break upon it, except as spray.

Returns were presented of the performances of a number of paddle-wheel ocean steamers for a period of 22 years, tending to prove how greatly the velocity had been increased. This was shown to have arisen from the augmented size and better build of the vessels, with greater power of engines and other engineering improvements. These tables showed the necessity of a careful selection of the period from which a mean average of velocity was deduced; for example, the *Hugh Lindsay*, H. E. I. Co.'s steamer, gave, in 1830, a mean average of 5½ knots per hour; whereas the best of the Cunard and of the Collins lines of steamers gave a mean average of 12½ knots per hour for the last three years.

In winding up the discussion, the dimensions were given of a great raft ship, called the *Baron of Renfrew*, which was built at Quebec in the year 1825, by the late Mr. Charles Wood, of Port-Glasgow. Her extreme length was 304 feet; extreme breadth, 61 feet; clear depth, 34 feet; registered tonnage, 5,294½ tons; and cargo of timber, 8,500. The draft of water at the end of the voyage, when water-logged, was 31 feet. She had four masts, and the sails of a 36-gun frigate. Her greatest inclination under press of sail was about 20 degrees. Her greatest speed before she became water-logged, but with 19 feet of water in the hold, was 8½ knots, which was reduced to 6 knots when she was quite full of water. She made

the passage from Quebec to the Isle of Wight in 48 days. It was due to Mr. Charles Wood to mention this daring innovation at so early a period.

DECEMBER 6.

"On the Drainage of the District south of the Thames," by Mr. J. T. Harrison.

DECEMBER 13.

Continuation of discussion on Mr. Harrison's paper.

INSTITUTION OF MECHANICAL ENGINEERS.

OCTOBER 26.

C. BEYER IN THE CHAIR.

"On the New Pumping Engines at the Birmingham Water-Works," by W. S. Garland, Soho.

"On an Escape Water-Valve and a Governor for Marine Engines," by R. Wadell, Liverpool.

"On an Improved Coking Crane for Supplying Locomotive Engines," by J. Ramsbottom.

"On an Improved Turn-Table," by S. Lloyd.

"On an Improved Apparatus for Preventing Explosions of Steam Boilers," by J. Rollinson, Brierley Hill.

DECEMBER 7.

W. FAIRBAIRN IN THE CHAIR.

A special meeting was held this day at Manchester. The attendance was particularly good, and there seemed to be a very general opinion, that it would be desirable to hold frequent meetings of the society in Manchester and other towns of mechanical importance. Being the centre of a district eminently distinguished for its extraordinary progress in the mechanical arts, Manchester has a claim upon the society not to be disregarded; and it is obvious that much good would accrue to the institution from the facility which such meetings would afford for practical illustration, by machines and models not easily removeable to a distance. The first paper read and discussed was—

"On a New Winding Engine, erected at Mr. Astley's Colliery, Dukinfield," by Mr. Fairbairn. This engine draws coal from one of the deepest pits on record. In a few months, the shaft will have been carried down to 650 yards. The engine was stated to be one of the largest of its class, having a 60-inch cylinder, with 8 feet stroke; and the very great speed of $22\frac{3}{4}$ miles an hour was obtained in drawing the coal up the pit, a load of 32 cwt. being drawn up from the bottom of the pit to the surface in one minute.

"On Mr. Taylor's Improved Water Meter," by Mr. B. Fothergill. One of the meters was exhibited in operation. Particulars were given of various experiments that had been made with the meter under different pressures, and with different velocities of discharge, from which it appeared that the meter registered the quantity of water accurately, under extreme variation both of quantity and pressure. The meter was stated to have been found very useful in measuring the quantity of water evaporated by steam-engine boilers, to ascertain the economy of their working.

"On the American Dry Clay Brick-Machine," by Mr. E. Jones, of Liverpool. The machine was self-feeding, and made the bricks complete by one process, ready at once for burning, without requiring the ordinary slow process of drying previously; it was capable of making 25,000 bricks per day, and effected a very important economy in the expense of manufacture, and also by enabling the manufacture to be carried on during the whole year. One of these machines was stated to be in efficient operation at Kirkdale, near Liverpool.

"On the Combing of Fibrous Materials," by Mr. B. Fothergill. The author described the various progressive improvements in combing, and the important changes recently effected by the introduction of Heilmann's machine; by means of which the breaking of the long fibres was prevented, and the different lengths of fibre were separated and assorted in the process of combing, so that great uniformity and perfection were obtained; besides which, the process was carried out so much more completely than by the former machines, that an important proportion of the material that was formerly rejected as useless, was now, by further combing, made valuable.

"On the Retardation and Stoppage of Railway Trains," by Mr. Fairbairn. This paper described several plans for increasing the power of stopping railway trains, and more particularly one invented by Mr. Newall, for applying simultaneously the breaks to the wheels of every carriage in the train; this could be done instantaneously, either by the guard or the engine-driver, by releasing the springs in the carriages that hold up the breaks, which were all in communication with a rod running the whole length of the train. The particulars of experiments were given that had been tried with this apparatus on the East Lancashire Railway, which showed a great increase of the power for stopping the train, giving the means of stopping within a considerably shorter distance than with the ordinary breaks.

ROYAL INSTITUTION.

DECEMBER 5, 1853.

W. POLE, F.R.S., IN THE CHAIR.

The Secretary announced that Professor Faraday would deliver a course of lectures in the Christmas vacation on voltaic electricity (adapted to a juvenile auditory), and that courses of lectures by Professors Tyndall, Wharton Jones, and Miller, would be given on the Tuesdays, Thursdays, and Saturdays before Easter. It was also stated that the Friday evening meetings would commence on the 20th of January, 1854.

ROYAL SOCIETY.

DECEMBER 5.

At the anniversary meeting to-day, the Earl of Ross, as President, occupied the chair, and delivered his annual address. After this, the *Copley Medal* was presented to M. Dove, of Berlin, for his work on the distribution of heat over the earth's surface.—Mr. Charles Darwin, the eminent naturalist, also received the *Royal Medal*, for his works on natural history and geology.

SOCIETY OF ARTS.

NOVEMBER 16, 1853.

At this, the first meeting of the hundredth session, Mr. Harry Chester, Chairman of the Council, presided, and delivered the opening address, after which the company separated for the examination of the "Models and Drawings of Articles of Utility, invented, patented, and registered since October, 1852."

NOVEMBER 23.

T. HOBLYN IN THE CHAIR.

"On Machines for Pulverizing and Reducing Metalliferous Ores," by C. F. Stansbury. The author first considered the conditions in which gold presented itself in the various localities where it was found. He then proceeded to describe the chief sources of supply in later times. He said that, notwithstanding the extensive distribution of gold, and the great desire of man to become possessed of it, the methods which human invention had up to this time devised for the purpose of obtaining it had been but partially successful. The processes for securing gold might be divided mainly into washing, smelting, and amalgamation. By washing, was meant every process which depended for its efficacy upon the superior specific gravity of the precious metal, as compared with the substances with which it was mixed. The process of smelting was not thought to be applicable to the wants of gold-seekers of the present day. That of amalgamation involved, of course, the previous reduction of the ore to a finely-divided state, in which alone the mercury could seize upon the gold and secure it; and the great object hitherto had in view had been, to produce machinery capable of bringing the rock to such a state of powder, as to allow the mercury to be brought into complete contact with every particle of the precious metal. This had been attempted by means of machinery for crushing, stamping, and grinding. In stamping machinery, there was a great loss of power by friction. In the "Mexican Raster," or "Arrastra" of California, the grinding was effected by the dragging, or rubbing, of stone millers over a bedstone of hard granite, enclosed by a wooden tub. This process was of course slow, and the friction great. In the old Chilian mill, large and heavy cast-iron wheels moved round in a trough over the ore to be operated upon. A large quantity of quicksilver was placed in the bottom of the trough, and water was supplied at the top. The ore was ground by the double action of rolling and grinding. This mill was the best of all the old contrivances for reducing gold ore, as it pulverized, washed, and amalgamated by one and the same operation. In Mr. Cochrane's crushing machine, the wheels of the Chilian mill were replaced by balls, worked by the pressure of a revolving dome of iron placed above them. The idea, though ingenious, was defective, as the friction between the balls and the dome would be equal to the work done; and as the basins remained horizontal, the ore, after being pulverized, had to be amalgamated in a separate apparatus. The only process which seemed hitherto to have answered all the conditions necessary to an amalgamating apparatus, was what was called at the diggings the miner's assay—a method employed at the mines for determining the value of ores which it was proposed to work. In this process the mortar and pestle were employed. Mercury was put in the mortar, the ore to be tested was thrown in, and covered with hot water, when the operation commenced. The pulverization was perfectly effected by the rolling and grinding, or rubbing action of the spherical end of the pestle; the mercury was kept at the point of crushing in the bottom of the mortar, and was kept heated by the boiling water. Here, then, were all the necessary conditions—perfect pulverization and instant amalgamation by pure and hot mercury. On a large scale, the cost of heating sufficient water to attain this result would, of course, be a practicable difficulty. In Mr. Berdan's machine, the principles of the miner's assay were closely followed, while the expensive process of heating water in large quantities was avoided. The novel features of the machine consisted in the arrangement of an inclined revolving basin, in connection with balls of corresponding size and weight, producing a rolling and grinding motion, which it was believed had never heretofore been attained, and in the heating of the mercury, which had never previously been attempted on a large scale. The peculiarities of the invention did not consist in the use of balls and basins, but in, 1st, the inclining of the shaft on which the basin revolved, which kept the mercury always at the crushing point, and caused the balls to work by gravity; 2d, the production of a combined rolling and grinding action by the contact of the balls; and, 3d, the addition of heat to the mercury by means of the furnace below the basin.

ONE HUNDRETH SESSION, 1853-54.

SUBJECTS FOR PREMIUMS.

The list of subjects on which the Council invite communications for premiums for the ensuing session, comprehends the following new heads. The numbers attached to each represent their position in the list:—

CLASSES I. TO IV.—RAW MATERIALS.

1. The best essay on the existing methods and most recent contrivances for crushing and dressing hard rocks, containing metalliferous ores or native metals.
2. An account of the details of copper ore, fuel, and the make of copper, in the different places where this metal is produced.

5. An account of the manufacture of tin, and of recent discoveries of new sources of supply.

8. An account of the best proportions for the production of the compound metal bronze, and the preparation of bronze washes.

11. An account of the manufacture of useful products from peat.

12. The best essay on the chemical composition of rocks, the changes which they have undergone, and are now undergoing, especially in relation to those which are used for building and other similar purposes.

13. The best essay on the properties, geological distribution, and working of flag, slate, and other stones used for paving.

15. The best account of the methods of manufacturing nitramarine, and for the best specimen produced in Great Britain.

17. The preparation of any colour, applicable to the japanned surfaces of papier maché, that shall be free from the brightness (or glare) of the varnished colours now used, but yet possess the same degree of hardness and durability.

18. The preparation of certain light colours to be used in enamelling or japanning slate or iron, that will stand the action of heat from the fire without blistering or discoloration, and be sufficiently hard to resist scratches.

19. A new and effective mode of protecting fine iron castings from corrosion when exposed to the atmosphere, without loss of sharpness, the clogging up of small parts, and the other evil consequences of paint, and without destroying the natural colour of the metal, as in galvanizing.

24. An essay on the modes of treating and preparing spices for the market.

26. The discovery of any new sources of supply of food, either by importation or by the extraction of nutritious matter from substances hitherto deemed unavailable.

27. An account of the gums of commerce, and particularly of such as are used in manufactures.

30. An essay on the various fluids used for lighting, with their relative degrees of illuminating power, portability, and cost, and their comparative liability to accident.

32. Improvements in the dye of woollen cloths, whereby the colour may be rendered permanent, and capable of resisting acids; to be cheaper than wood or indigo.

33. An essay on the nature and properties of dyes, in their application to silk and other fabrics.

39. The best samples of ornamental woods from New Zealand or any other British colony, suitable for the manufacture of furniture.

40. The discovery of an economic substitute for the teazels used in raising the face or the nap of cloth.

42. The importation from any British possession in Africa, of not less than 20 pounds of silk proper for manufactures.

44. A method of preparing an engine size for the use of papermakers, superior to any now in use.

45. The best account of the mode in which size from sea-weed is prepared and used by the Chinese.

Nos. 1, 8, 9, 11, 12, 13, 14, 21, 22, 23, 26, 28, 29, 30, 31, 37, and 39, of last year's list, as printed at page 240 for January last, are expunged.

CLASSES V. TO X.—MACHINERY.

46. An account of recent improvements in, or applications to, the furnaces of steam-engine boilers, for the consumption or prevention of smoke, without increasing the expense of working.

47. An account of improvements in the furnaces of manufactories, especially in glassworks, ironfoundries, and the like, for the consumption or prevention of smoke.

51. A cheap and simple mechanical register, not liable to get out of order, to be attached to carts and other vehicles, so as to measure and indicate correctly the distances travelled.

52. Improvements in the construction and furnishing of public conveyances suitable to the streets of London.

56. An account of the machines at present in use, and for any improvements in the same, for sewing garments and other articles.

57. The best and most economical mode of cutting out boots and shoes by machinery, so as to effect a saving of time and material.

58. The best paper-ruling machine.

60. The invention of a simple machine, by which plates of cold iron, say 7 feet by 3 feet, and from $\frac{1}{4}$ th to $\frac{1}{2}$ inch thick, may be readily cut, either lengthwise or across, in equal parts, or in any other proportion that may be required.

61. The successful application of machinery to the manufacture of the separate parts of cheap clocks.

62. An account of recent improvements in the manufacture of sugar from beet-root in Great Britain and Ireland, and of the results obtained.

65. The best design and working drawings of a model house, suitable to the general requirements of the industrial classes, and of the furniture and modes of fitting such dwellings, with estimates of cost.

66. The best essay, illustrated by actual experiments, on the fittest material for the walls and ceilings of rooms intended for lectures and similar purposes, and also on the best form thereof.

67. Improvements in the employment of gas for domestic purposes, especially for heating, ventilating, and cooking, with the cost and results thereof.

68. The application of electricity to the discharge of fire-arms.

71. The invention of a marine barometer, which shall fulfil all the conditions necessary to make it a good and reliable instrument, and be sold at a moderate price.

72. The invention of an anemometer, for measuring the force, velocity, and direction of the wind at sea.

73. A good speculum ani, which, with facility of introduction, shall afford the means of exposing a considerable surface of mucous membrane, and applying escharotics.

Nos. 41, 42, 48, 49, 51, 53, 54, 55, 56, 57, 58, 59, 62, 63, 64, 65, and 67, of last year's list, are expunged.

CLASSES XI. TO XXIX.—MANUFACTURES.

Textile Fabrics.

74. An essay on wools—the manner of rearing and feeding the sheep, and improvements in preparing the material for use.

75. A more economic method of employing gold and silver in woven fabrics.

76. An account of improvements in the methods of transferring the pattern from the original design to the cards of the Jacquard loom.

77. The successful application of some new means (as electricity, for instance) for producing ornamental designs in woven fabrics, which shall be cheaper and easier of application than those at present employed.

78. An account of the methods at present practised in France for dyeing and dressing morocco leather.

79. The best mode of dressing kid and calf kid, for the upper leathers of boots; the improvements required are, strength of the grain and a good firm black dye.

80. The best specimen of paper, not less than 1 cwt., produced either wholly or in part from new materials, such materials not being more costly than those now used, with full particulars as to the manufacture.

81. The best essay on the preparation of paper for India, and hot climates generally.

82. The best method of colouring paper in the pulp with indigo, and with greens of various hues, the colours not liable to be affected by gas.

83. Improvements in the manufacture of transparent papers.

84. The best method of glazing paper in the web.

86. The invention of a means of copying letters, by which the inconvenience at present attending the use of the "style" may be obviated, and both the original and the copy shall be permanent.

88. The best mode of finishing the edges of machine-made bobbin lace (in imitation of pillow lace), so as to supersede the use of a separate pearl edge, usually sewn on.

90. A ready mode of taking casts of the feet, which may be used as lasts for making boots and shoes.

Nos. 74, 76, 77, 78, and 79, are expunged.

Metallic, Vitreous, and Ceramic Manufactures.

91. The construction of moulds without seams or joints for metal casting, in the round, or in relief.

92. The production of castings in iron, equal in sharpness and delicacy of surface to those now imported from Berlin.

93. Improvements in letter locks, which shall prevent the combinations being ascertained by any other means than working out the entire system of changes.

96. The best specimen of figure-chasing in silver, out of the solid plate, suitable for medallions, vases, &c.; combining good execution and workmanship, with taste and judgment in the selection of the design.

97. The best original design or exact copy of a good piece of ancient glazing in plain glass, in which the lead lines give the geometrical pattern.

98. The best specimen of a cistern for household purposes, made of glass in one piece, and capable of holding not less than 80 gallons.

99. A cheap quality of glass, in which coarseness and want of transparency are not regarded, applicable for drains, water-pipes, sinks, shelves for larders, dairies, &c.

100. The best account of the causes of the defects in flint glass, with the means which have been employed to remedy the same, accompanied by suggestions for the improvement of the manufacture.

101. The best specimens of glass for chemical use, capable of resisting a high degree of heat without softening, and not liable to break from changes of temperature.

102. The best specimen, in imitation of Venetian or ancient glass, of a useful jug, drinking glass, or dish; every specimen must be left exactly as finished by the glass-blower.

105. The best copy of some work of Italian art, containing one or more human figures, painted on china, of a superficies of not less than 64 square inches.

Nos. 83, 86, 87, 88, 89, 90, 91, and 92, are expunged.

Miscellaneous Manufactures.

110. A means of imparting additional firmness and tenacity to the clay used for modelling, without diminishing its plasticity.

111. A means of rendering the plaster used for casts less absorbent and more adhesive, so as to facilitate its use for repairing purposes.

112. The best means of utilizing refuse ores, refuse coal, and impure approximations to coal.

113. The best means of turning to useful account slag, in a coarse, refined, or combined state.

Nos. 97, 99, 103, and 104, are expunged.

CLASS XXX.—FINE ARTS.

117. The best specimen of modelling and medal die sinking. An impression from the die, and the original model to be sent to the Society.

118. The best design for a flower trough or vase, ornamented in bas relief, and

capable of being cast from a mould in one piece, and of being produced in terracotta.

119. The best cheap set of plain vases in china, earthenware, or terra-cotta, suitable for mantel-piece ornaments.

120. The best cheap set of plain vases in glass, suitable for mantel-piece ornaments.

121. A table cover, showing the best and simplest design, and manufactured in either wool, damask, felted, or oil fabrics.

122. The most simple and elegant three or five light gas chandelier, suitable for a drawing-room.

123. A candle lamp, showing the best and simplest design, and capable of adaptation to the different sizes of candles.

124. The best cheap ornamental bracket, in one material.

125. The best cheap ornamental bracket, in two or more materials.

126. The best design for a pair of entrance doors, with open-work cast-iron panels.

127. The most simple and elegant fender and set of fire-irons.

128. The best series of four outline drawings in illustration of Longfellow's poem, "Building the Ship."

129. The best series of four outline drawings applicable to ornamental purposes, and illustrative of acts of mercy.

130. The best series of four botanical and structural drawings of a forest-tree.

131. The best series of four botanical and structural drawings of one of the Cerialia.

Nos. 106, 107, and 108, are expunged.

All communications and articles intended for competition must be delivered to the Secretary, at the Society's house, free of expense, on or before the 31st of March, 1854. This restriction, as to the date of receipt, does not apply to those articles of colonial produce which were not in last year's list.

Successful candidates will be communicated with on or before the 14th of June, 1854. Unrewarded communications and articles must be applied for at the close of the Session, between the 14th of June and the 5th of July, 1854, after which date the Society will no longer be responsible for their return.

MONTHLY NOTES.

THE CHIVALRY OF INTELLECT.—The King of Bavaria has just done that which will earn for him the grateful acknowledgments of men of science and letters throughout the whole world. He has founded an order of intellectual chivalry, under whose banners are to be gathered the foremost leaders of authorship, art, science, and music. The designation by which this noble congress is to be known is the "Order of Maximilian the Second," and the original Forty lofty names have already been selected for it. They bear the name of chevaliers or knights; and their decorations consist of a gold cross, enamelled in dark blue, with a white edge, framed with a garland of laurel and oak, and surmounted by a regal crown, each of the corners having four rays, with the King's effigy in a central crowned escutcheon, and the motto "Maximilian II., King of Bavaria." The reverse bears the symbol of the branch of pursuit to which the holder belongs. When will the science and literature of our country meet with such distinctive marks?

THE GLASGOW AGRICULTURAL SOCIETY AND CITY SEWERAGE.—An important movement has been made by the Glasgow Agricultural Society, in offering a prize of fifty pounds for the "best essay on the means for most economically and effectively collecting, storing, conveying, and distributing, as manure for land, the soil sent off by the sewerage of the city of Glasgow." It is intended to bring forward by this means the most practicable plans by which to secure the efficient cleansing of Glasgow, combined with the most economical system of applying the collected matters to agricultural purposes. With this view, the Society has very properly intimated that all the competing schemes must be specially devoted to the sanitary improvement of the city.

TUNNELLING AND EXCAVATING MACHINE.—Mr. Talbot, an American engineer, has just successfully introduced a rotatory steam tunnelling machine, which goes through the hardest of earth's crusts with great ease, doing away entirely with the slow processes of hand boring and blasting. The action is a compound cutting and crushing one, produced by revolving steel discs, set to act in successive series, and each describing segments of circles running from the centre to the edge of the cutting, with a gradual movement round the main common centre—the steam-engine constantly acting to push forward the entire machine in a line coincident with the axial line of the cutting. In a late practical exhibition of the powers of the borer, the visitors were astonished to find that, when cutting into rock obliquely, the working action was perfectly uniform, the arms and cutting discs engaged upon the solid hard rock going through their work as if they were merely working in air. An excavation 17 feet in diameter was cut at the rate of 18 inches per hour, four men only being required as attendants, two of them devoting their attention exclusively to the engine. The weight of the machine, exclusive of its engine and hoiler, is 75 tons.

AMORPHOUS PHOSPHORUS FOR LUCIFER MATCHES.—The dreadful disease generated amongst the operative makers of lucifer matches, from the use of common phosphorus—as in the case of the painter's cholera from the use of white-lead—has naturally excited the close attention of scientific chemists for some years; but only now has anything satisfactory been done in the way of a remedy. Schröter's amorphous phosphorus—now a discovery some years old—seems to have reached the evil. The amorphous phosphorus is totally unlike the ordinary sub-

stance, as well in external appearance as in its chief characteristics of action. It is not soluble in sulphuret of carbon—it is not poisonous—exhales no objectionable fumes in the atmosphere—nor does it ignite by the usual friction, nor in contact with iodine. It is only when mixed with certain other matters that it explodes. Mr. Albright's patent of 1851 has at length reduced the new material to a commercially workable condition. In this process, the common phosphorus is placed in a glass vessel, inside a closed one of iron, from which a pipe passes to a vessel containing water. The cast-iron vessel is placed in a sand bath, which again is inside a metallic bath, to which the operating heat is applied. Moderate heat causes the dislodgment of bubbles from the vessel containing the phosphorus, these bubbles igniting on coming into the air. When the bubbles cease to flow, the temperature is raised to 500° Fahr., and it is kept at this point until the amorphous condition is acquired. After this the material is cooled down, and is then levigated under water and strained, being finally purified by spreading in thin layers on heated iron or leaden plates. The change in the phosphorus is very peculiar. Originally it is transparent, and of a pale yellow or white colour, and so combustible that it must be kept under water. But the heating changes it to a soft opaque consistence, which, when pulverized, produces an uncrystalline powder, of a red colour, and incapable of combustion at a lower heat than 482° Fahr. Messrs. Sturges, of Birmingham, and Messrs. Dixon, of Newton Heath, near Manchester, are now using the new phosphorus, chlorate of potash being used as the mixing material.

STRINGFELLOW'S POCKET BATTERY.—This is an ingenious arrangement for supplying a continuous stream of electric fluid for medical purposes, and it especially recommends itself by its extreme portability, and by the convenient manner in which it can be applied. A battery of sufficient power for most purposes is contained in a holder no larger than a lady's card-case, as shown in fig. 1, and it owes its comparative compactness to contrivances by which an immense number of minute surfaces of suitable metals are arranged so as to induce the voltaic action. Fig. 2 represents a portion of a battery, the whole consisting of the repetition of this "element," and being unlimited as to size. In making this "element," a narrow strip of thin zinc is bound round with a flat copper wire, some non-conducting substance, as cotton, silk, or gutta serena, being interposed between the two metals. At each end of the element, short lengths of flat copper wire are made to project, and these are soldered to the ends of the zinc plate of the adjacent element. Any metals capable of inducing voltaic action may be used, and the inside strip may be covered by the outer metal in a variety of ways. We have before us specimens of various arrangements. In one of these, rows of transverse slots are cut out of the enveloping metal. In another are holes, like perforated window blinds; whilst in a third, the outside metal is in the form of wire-gauze, which last is said by the inventor to act very well. The elements are soldered together in sets of ten or eleven each, and two or more of these sets are hinged together to form a battery. At each end of the battery is fixed a small socket—one being the positive pole, and made of gold; the other the negative, and made of silver. These sockets project through holes provided for them in the case, and it is to them that the conductor cords are attached by a common clasp. These cords have a fine metal wire twisted



Fig. 1.

up with them, and covered by an external braiding of silk or mohair. They terminate in small metal plates, which are provided with slots at the back for the introduction of a tape to bind them to the body. The battery is excited by being slightly moistened by dilute acetic acid, and the conductor plates are wetted and applied at the parts between which it is wished to pass an electric current. The battery, in its neat case, may be carried in the pocket, or worn about the person in any convenient manner.

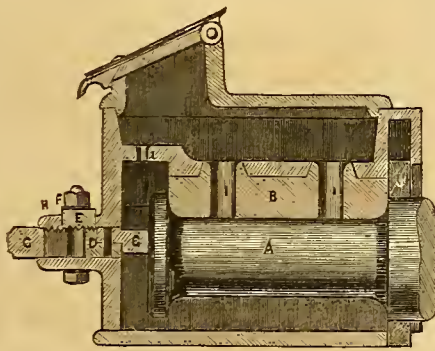

Fig. 2.

SELF TOP-STRIPPING CARDING ENGINE.—There is now at work, at the Merrimack Mills, Lowell, U.S., a cotton carding engine, which effects "top-stripping" in a very perfect manner. The new movements are applied, in this instance, to an engine built expressly for the purpose, the main cylinder being four feet in diameter by three feet wide, and having 28 tops. The stripping action is effected by a segment which passes over the tops, carrying machinery for deliberately picking up each top, stripping it, and then returning it to its place, each alternate top being stripped as the segment works through its traverse. Of course, in such an arrangement, a great array of separate movements is necessary; but the inventor, Mr. George Wellman, after many years' labour, has succeeded in reducing the combined action to great simplicity of details, and the engine now works most satisfactorily, and produces far greater uniformity of carding than is possible in the manual process. The invention has been patented in this country by Mr. J. H. Johnson, of Lincoln's Inn Fields.

SHEKLETON'S UPRIGHT TUBULAR BOILERS.—Mr. J. Shekleton, of the Dundaik Iron Works, is now making a simply arranged boiler of this class, possessing some important points as regards economy of fuel. The boiler is little more than a common cylinder set on end, without any brickwork, being merely carried on a neat metal base frame. The furnace, with its fire-box, is completely surrounded with water, the lower ends of the vertical tubes opening into the top of the fire-box; whilst the upper ends similarly open into a smoke-hox in the top of the boiler's barrel, whence a conical chamber extends to the chimney flue. Two of these boilers have been at work in Mr. Shekleton's works for three years; and one is now working at the Lead Mines, Castleblaney, burning turf. Considerable economy is manifested in both applications.

BARRANS' RAILWAY AXLE-BOX.—The end wear of railway journal bearings is a serious evil, most deeply felt by all superintendents of rolling stock. When such wear takes place, it brings with it an amount of lateral play, which involves side swerving and excessive oscillation in the carriages. Mr. Joseph Barrans, of New Cross, London, remedies these objectionable points by the introduction of an end bearing piece, adjusted so as to work just clear of the axle end, so that lateral motion is impossible; and he also adds a grit-shield, to keep out all foreign matters from the working surfaces.



The engraving represents such an axle-box in longitudinal section, where A is the axle journal, and B its bearing, C being the adjustable filling or end stop-piece. This piece of metal is kept in position by a transverse bolt, D, passed through a slot in the filling piece, and the nut, E, secured in its place by a second nut above it. The nut, E, is notched to fit to corresponding notches on the piece, C, so that all is held perfectly secure, whilst an easy means of adjustment is afforded by slackening off the nut, F, and slipping the notched faces as required, by the wear of the brass, G, let into and pinned upon the piece, C. A boss, H, is cast on the front of the axle-box, for the filling piece, C, to work through. At I are the oiling holes; and J is the wooden grit-shield fitted into a guide groove in the box. The plan has been some time at work on the South-Eastern, and London, Brighton, and South Coast lines, with the best success. In addition to the particular modification of axle-box which we have engraved, Mr. Barrans employs several other arrangements for the same end. In one of these plans, the end set-up piece of steel is adjusted to the outer end of the axle by a cotter wedge, with screw and nut, like the adjustment of an ordinary connecting-rod. In another, the set-up piece is itself a wedge; the adjustment being effected by an underneath set screw. And a third, and extremely neat contrivance, is that of a set screw, set into the axle-box from the outside, and pressing up the set-up piece in the box, in the line of the axle.

HOLLAND'S PATENT UMBRELLAS (INFRINGEMENT).—This action, in the *Court of Queen's Bench*, was for the recovery of damages for an alleged infringement of patents obtained by Mr. Henry Holland, of Birmingham, in 1840 and 1851, for improvements in umbrellas and parasols. The defendant is Mr. Thomas Fox, who is engaged in the same business in Sheffield. The plaintiff's patents were for improvements in the manufacture of the ribs and stretchers used in umbrellas and parasols, and of the joints or bits by which the stretchers were attached to the ribs, and to the runner on the stick. These ribs and stretchers were made of iron, and were in the form of perfect cylindrical tubes, and were said to combine the quality of strength with those of lightness and flexibility.

The articles manufactured by the defendant were said by the plaintiff to have been made upon the same principle, except that, instead of being perfect cylinders, they were imperfect, the edges not being closed or united together. They were constructed somewhat on the principle adopted in the Britannia tubular bridge; and it was said by the defendant that this mode of construction was not only a new and different principle from that adopted by the plaintiff, but combined the requisite qualities of strength, flexibility, and lightness in a much greater degree than was done by the plaintiff's invention.

The plaintiff relied upon two breaches; and in the result the jury found, as to one, in favour of the plaintiff; and, as to the other, in favour of the defendant.

The effect of this finding was, that the defendant had infringed the patent which was shortly about to expire, but that he had not infringed the more recent patent.

CAPTAIN NORTON'S RAILWAY DANGER SIGNALS.—As a means of communication between the guards and drivers of railway trains, Captain Norton suggests a whistle, which, as he remarks, "is as old as the days when the Bible was written, having been used for signalling in time of war." This is a whistling-holt, or arrow without feathers, to be shot from a steel cross-bow by the guard of the train, a few yards in a direct line over the head of the driver of the engine, he having a shield or screen behind him, reaching a foot above his head. No arm, ancient or modern, is more correct in aim than the cross-bow—witness the exploit of William Tell; also of the man at Liverpool, who, for a wager, a few years ago, as appeared in the public papers, broke a glass tumbler placed on the head of another man, at the distance of twenty yards; he repeated this feat several times. The guard of a railway train can place the bow on the roof of the carriage in his front, in a position marked out, so that every shot will follow the same track, without the necessity of raising the bow to his shoulder or taking any aim. The Chinese have a very ingenious cross-bow, with a magazine for its bolts, which fall into their places in succession; the lever is moved like the handle of a pump, so that the action of shooting is like that of pumping; and such a plan is just what is wanted in this case. The indefatigable Captain has not been contented with the mere suggestion, but he has put the whistling contrivance into actual practice, using it as a rifle shot, with a rifle of the same bore as the present military rifle. When firing the piece so charged, he distinctly heard the whistle throughout the entire flight of the missile, 900 yards. The idea is taken from the Chinese whistling arrow. The guard of the train may fire this whistling rifle-shot from a short rifle, loading at the breech, and using a small charge of powder—the shot having a grooved "sabot," is for a rifle loading at the muzzle; the shot with the plain "sabot" is for a rifle loading at the breech—the rifle grooves in this latter being, of course, formed by the shot passing through the rifles of the barrel. The double flute-like whistle caused by the opposing air on the front and sides of the shot, will solve the problem so long agitated, as to what distance of the shot's flight is the rotatory motion continued. Fig. 1 represents the shot with its plain sabot detached, drawn half the real size. The sabot is of limewood, or other tough substance; this, elongated to twelve inches, becomes the shaft of the whistling arrow, or detonating bolt; a simple bolt or blunt-headed arrow may be shot by the guard of the train against a Chinese gong, placed behind and above the head of the driver of the engine. Different sounds may be produced, according to the matter the head of the arrow or holt is made of. The whistle is nothing more than a hollow cylindro-conoidal shot, with the lateral hole to admit the opposing rush of air, formed in the conoidal part, so as to catch the air, just as the hole in a flute receives wind from the player's lips. The inventor has also tried further experiments. Thus, a rod of iron, eight feet high, was fixed vertically, and on the top of it was tied a paper bag, containing a pound of blasting-powder mixed with sawdust; a slip of slow-match was lighted like a cigar with a Vesuvian, and quickly drawn up by a cord, so adjusted as to enter the bag of powder and explode it. The flash from the powder would resemble lightning, or the blowing up of an ammunition waggon, so as to be seen far and wide. Captain Norton proposes to have Bengal and other lights attached to the top of the iron rod, which may be instantly raised to its position, like the guard of a carving-fork; the fire of the powder igniting the lights, the flash would attract and the lights would fix attention. After this, a small paper bag of gunpowder, having a cord passing through it, with the attached slow-match ignited, was thrown by the hand upwards into the air; when the bag reached the length of the cord, the lighted match entered and exploded the powder. The inventor's frictional appliance will also answer this purpose, and even more readily, for it requires no previous preparation, neither damp nor rust can affect it, nor impair its perfect efficiency; the hurr-headed wire-pin used in it may be doubled in form like the letter U, to insure greater certainty of fire; the cord can also be doubled. Capt. Norton is preparing a balista with a steel-wire spring, which shall throw a bag of powder to the height of fifty feet, or more, into the air, and instantly explode it by the above-mentioned means. Fig. 2 is a sketch of Capt. Norton's fog-signal—half size. The apparatus is a small piece of seasoned wood, such as ash or elm, having a chamber drilled into it, to receive about three drachms of Hall's rifle-powder, stopped with a wooden plug glued in; a small touch-hole on the side receives a quill, charged like that for firing cannon by percussion, but more simple in its construction. The fault of the fog-signal at present in use is, that the tin-case containing the charge of powder is rent by the crush of the wheel of the engine—the percussion powder, or other powder, is, in consequence, not confined when its explosion takes place. The part containing the reporting-charge should not be rent, but only flattened or spread out by the crush of the wheel of the engine. The paper-case of this signal is of the same form as that of a squib or port-fire; it may be made fire-proof by a solution of alum, and water-proof by a coating of paint or varnish. A proof of its enduring efficiency is, that if run over by the wheels of a light carriage, it only flattens or spreads out, but does not burst, therefore no part of the powder-charge is lost; and if it is afterwards placed on the rail, and the engine allowed to pass over it, it will certainly explode; this has been repeatedly proved. The inventor recommends a charge of a mixture of chlorate of potash and sulphuret of antimony, equal parts, with a little coarse emery powder added, to cause the friction on the

Fig. 1.



Fig. 2.



rail by the pressure of the wheel of the engine, which causes the explosion of the mixture confined within. The coarse emery powder, with a little of the mixture, may be enclosed in a small paper bag, and placed in the centre within the case. The ends of the case are stopped with thin pieces of cork glued in. The part a is a leaden clip for fastening to the rail.

STOP MOTION FOR "FLOATS" IN WEAVING.—Mr. Singleton, of Over-Darwen, has devised a self-acting loom stop-motion, for preventing the occurrence of what are technically known as "floats," or open places in the piece being woven, hitherto a great difficulty in the way of every weaver. A pointed finger is so arranged near the surface of the newly-woven cloth, that, on the formation of any open part, the point passes through the piece. This brings the finger or detector into such a position, that it may be acted upon by the beat-up stroke of the reed. A traverse movement is thus communicated to the operating finger piece, and the latter being set to act in concert with the usual stop-motion or shifting action of the driving band of the loom, the loom is at once brought to a stand, so that the weaver can remedy the defect in his piece.

PROGRESS OF SCREW PROPULSION—MARINE MEMORANDA.—The *Orion*, originally intended to be an 80-gun sailing vessel, has been lengthened at Chatham, to mount 90 guns, like the *Agamemnon*, and, like that ship, she is now to have a set of Messrs. Penn's oscillating engines, of 600 horse power. The *Repulse* has gone through a similar course of alteration at Pembroke, and is to have engines of 600 horse power, by Messrs. Maudslay. The *Pylades*, 50, frigate, building at Sheerness, is to be fitted with engines of 350 horse power, by Messrs. Penn, similar to those in the *Euryalus*, 50, built at Chatham. The *Curaçoa*, 50, frigate, building at Pembroke, is to be fitted with engines of 350 horse power, by Messrs. Maudslay. The *Harrier* sloop, building at Pembroke, is to be fitted with engines of 100 horse power, by Humphrys, Tennant, and Dyke. The *Falcon*, 16, building at Pembroke, and the *Faen*, 16, building at Deptford, are to be fitted with engines of 100 horse power to each, by Miller, Ravenhill, Salkeld, & Co. The *Hornet* sloop, building at Deptford, is to be fitted with engines of 60 horse power, by Bolton and Watt. The *Swallow*, 8, and the *Ariel*, 8, both building at Pembroke, are to be fitted with engines of 60 horse power, by Miller, Ravenhill, Salkeld, & Co. The engines of these vessels are all adapted for screw propellers. Thus the navy of 1854 will be strengthened to the amount of two 90-gun screw ships; two 50-gun steam frigates, equal to the *Imperiouse*; three 16-gun steam sloops; and two 8-gun steam sloops.

The great advantages possessed by the anthracite or stone coal of Wales over the bituminous kinds for steam purposes, has of late been so fully acknowledged, that the West Indian Royal Mail Steam Company have been induced to take a colliery in Pembrokeshire, for the purpose of supplying their large steamers with anthracite coal. In Pembrokeshire and Carmarthenshire, this species is found in the greatest abundance. It has been tried, and found to answer, and will now be brought into more general use, as at Llanelly several large screw steamers have been taking in a supply for steam purposes. The Earl of Cawdor lately stated in public, that the vast impulse that steam communication had given to commerce had developed the advantages derivable from the anthracite of Wales, and that it would daily come more into use for steam purposes.

Hitherto the Dublin consumers of sea-borne coal have had to rely for their supplies upon the means of conveyance afforded by some half-dozen captains of colliers, whose proceedings keep up the price of the fuel to a seriously high point. Just now, however, screw-steamers are being called in to do away with this monopoly. The Dublin factors have arranged with Belfast builders for the fitting out of four large screw-ships to carry on the trade between the ports of Whitehaven and Dublin, so that we shall shortly hear of the screw being instrumental in the reduction of one of the most important articles of consumption in the Irish capital.

The sailing of the clipper ship *Matilda Wattenbach*, and the American steamer *Golden Age*, within a day of each other, for Australia, is looked upon with much interest, as affording the means of deciding whether clipper sailers or well-appointed steamers are the best adapted for carrying the mails between England and the Australian colonies.

The *Brilliant*, auxiliary screw clipper brig, which we noticed a few months back as having been altered from her original character of a sailing vessel, to render her more suitable for the Southampton and Madeira passenger trade, has been withdrawn from that station, where she was such a universal favourite. Her destination is now the Brazils, and she has just sailed with passengers and cargo for Pernambuco and Bahia, still, however, touching at Madeira. It will be remembered that she was built as a yacht by Messrs. White & Cowes.

Mr. Maxwell Scott has been addressing the Liverpool Polytechnic Society in reference to a screw propeller of his invention. It is considered by many parties that the propelling action of the screw is entirely derived from the outer part of the screw, and that the part near the boss is an impediment or cause of loss. Mr. Scott removes a great portion of this inner part, leaving only a part at the entering end of the screw, sufficient to form an arm for the support of and connection to the boss of the outer-acting portion of the blade. This is all very well, if the arm does not require to be so increased in dimensions in order to give sufficient strength, as to offer of itself a greater impediment than the original entire blade. Another portion of Mr. Scott's invention possesses, we think, much more practical value. This is a method of manufacturing the screw. The arms and boss are of wrought-iron; the arms are turned, and of sufficient strength relative to the screw shaft; the blades are cast, with holes partly through, and afterwards bored out to receive the turned part of the arms; thus, they easily turn round when required. Now, supposing we have to make a screw for a vessel, we determine upon the diameter and pitch we think best. The screw being made, we fix it on the arms by means of a cotter. The vessel is then tried, and if the engines go too fast, we put her on the gridiron, alter the pitch, and take a note of

the results, until we arrive at the pitch most suitable, which being found, we then fix the blades permanently to the arms, and then we possess, in every particular, the best screw we can have for the vessel. There are other advantages gained by this mode of manufacturing the screw—namely, 1st. The screw is much lighter and stronger. One of the screw steamers in the Mediterranean trade constantly broke her propelling shaft whilst driving a screw of thirty-nine cwt.; since then, a screw having been made for her of twenty-seven cwt., it is found her propeller shaft now does its work properly. In a heavy head sea, the effect of a heavy screw falling in the water is rather startling, and has a tendency to shake and strain the vessel, more especially at the stern-post; this we may readily conceive, when we call to mind the numerous instances in which screw steamers return to port leaky. 2d. The screw can be made suitable to the vessel, so as to obtain the best result out of her, as in the case of the *Conflict*. This steamer has been in commission some years with an unsuitable pitch, and must, therefore, have expended uselessly a great amount in fuel, with an unsatisfactory result as to speed. 3d. That in case of a portion of a blade being broken, another blade can be easily put in its place without the necessity of removing the shaft. 4th. That in case of having the screw to lift through a well hole, as adopted in the royal navy, the shaft could be made in one piece with the arms, the blades brought close down to the shaft, thus saving the weight of the boss, and by being made in three pieces could be readily removed. The patent propeller has been tried on several vessels—in the *Lucifer*, an increase of speed of $1\frac{1}{2}$ miles per hour was gained, with a reduction of 11 strokes of the engine per minute. In the *Weaver*, which plies from Runcorn to Northwich, and where it is in permanent use, it was more fully tried, and gained an increase of speed with a reduction of 40 revolutions of screw per minute, accompanied with a saving of nearly 15 per cent. of fuel, shown by the month's returns, besides the saving in wear and tear of machinery.

PROVISIONAL PROTECTIONS FOR INVENTIONS UNDER THE PATENT LAW AMENDMENT ACT.

When the city or town is not mentioned, London is to be understood.

- Recorded August 9.
1853. Henry des Moutis, 16 Castle-street, Holborn, and Paris—An improved system of publicity.
Recorded October 5.
2272. Alexander Turriff, Paisley—Improvements in retarding apparatus for the prevention of accidents on railways.
2278. Henry Stevens, Trafalgar-square—Improvements in the preparation of vegetable substances, for the purpose of preserving the same.—(Communication.)
Recorded October 11.
2323. John C. Sharp, Paisley—Improvements in retarding apparatus for the prevention of accidents on railways.
Recorded October 12.
2344. Robert W. Waithman, Bentham-house, Yorkshires—Improvements in apparatus for applying paint, varnish, and other liquid substances, and also for cleaning carriages, ships, roadways, houses, and other buildings.
Recorded October 14.
2364. William Jones, Porchester-street—Invention of a certain chemical compound or compounds applicable as a remedy for cuts, scalds, burns, wounds, and accidents of a similar nature, to which the same can or may be applied.
Recorded October 19.
2407. Peter A. le Comte de F. Moreau, 4 South-street, Finsbury, and Paris—An improved composition to be applied in substitution of bone and horn.—(Communication.)
Recorded October 20.
2428. Jonathan Woofenden, Belfast—Improvements in power-looms for weaving.
Recorded October 21.
2432. James G. Marshall and Peter Fairbairn, Leeds—Improvements in machinery for combing flax, tow, wool, and other fibrous substances.
Recorded October 24.
2454. Charles F. Blunt, 19 Montague-place, Russell-square—An improved artificial fossil coal fuel, which he desires to denominate "Blunt's Diamond Coal Fuel."
Recorded October 27.
2490. William M'Naughton, Manchester—Improvements in printing yarns or worsteds for weaving carpets, also in printing carpets, woollen, silk, cotton, and other textile and felted fabrics or fibrous substances.
Recorded October 28.
2499. William Thompson, 6 Clayton-street, Lambeth—An invention for instantaneously extinguishing conflagrations in ships' holds, warehouses, and other buildings.
Recorded November 1.
2520. John Bottomley, Bradford—Improvements in ornamenting textile fabrics.
2532. Thomas S. Bale, Caudon-place, Stafford, and Daniel Lucas, Stoke-upon-Trent—Improvements in ornamenting the materials of, and articles manufactured in, pottery, as bricks, tiles, slabs, &c., and also in glass, slate, stone, and other plastic substances.
Recorded November 2.
2542. Benjamin Butterworth, Calder-cottage, near Rochdale—Improvements in combining oil with other liquids for the obtaining of a new lubricating compound.—(Partly a communication.)
Recorded November 3.
2554. Peter Hindle, Ramsbottom, Lancaster—Improvements in power-looms for weaving.
Recorded November 4.
2558. James Scott, Shrewsbury—An improved apparatus for shifting carriages, waggons, engines, and other vehicles on railways and tramways.
Recorded November 5.
2570. John B. Nicklin, Bartbolomew-lane—Improved gelatinous or glutinous compounds for lubricating railway and other machinery.

Recorded November 10.

2601. James Atkins, Birmingham—An improvement or improvements in ash-pits for grates.
2602. William Pidding, Tachbrook-street—Improvements in the manufacture of fabrics made of silk, cotton, wool, flax, hemp, straw, grasses, fibres, mohair, and other hair, spun glass, and enamelled, glazed, or plain wire, and in the application of some of these materials, and also in the machinery or apparatus connected with such manufacture.
2603. William Rodger, 9 Shawfield-street, Chelsea—Improvements in anchors.
2604. James Stevens, Darlington Works, Southwark Bridge-road—Improvements in the steps or bearings of the axles or shafts of gas meters.
2605. Sannel M. Folsom, Massachusetts, U. S.—A new or improved instrument for ironing clothes or various other articles.—(Communication.)
2606. Peter Armand Le Comte de Fontaine Moreau, 4 South-street, Finsbury, and Paris—Improvements in preventing accidents on railways, also in shifting and lifting railway carriages.—(Communication.)

Recorded November 11.

2607. William Parker, Birmingham—Improvement or improvements in bearings for machinery.
2608. Solomon Sturm, Carpenter's-buildings, and Vienna—Invention of machinery for the manufacture of optical lenses.
2609. Alexandre A. V. Sarrazin de Montferrier, 4 South-street, Finsbury, and Paris—Invention of a new rotary steam-engine.
2610. Edward G. Banner, Cranham-hall, Essex—Improvements in saddlery and harness.
2611. Henry Walker, Gresham-street West—Improvements in means of communication from one part of a railway train to another.
2612. James Willis, Wallingford, Berks—Improvements in buckles.
2613. Richard Dryburgh, Leith—Improvements in the means of holding staves while being cut.
2614. William Steel, Glasgow—Improvements in machinery or apparatus for mashing malt.
2615. John Platt, Oldham—Certain improvements in apparatus or machines for forging, drawing, moulding, or forming spindles, rollers, bolts, and various other articles in metal.
2616. Henry Kilshaw, Birch, near Middleton, and Richard Hacking, Bury, Lancashire—Certain improvements in machinery or apparatus for spinning cotton and other fibrous substances.
2617. Abel Easton, Barnard's-inn—An improved lamp.
2618. Abel Easton, Barnard's-inn—Invention of a liquid chemical compound for the production of artificial light.
2619. James H. Dickson, Evelyn-street, Deptford—Improvements in the process of preparing flax or similar fibrous material, and rendering it fit for spinning and weaving.
2621. Johan M. Levien, Davies-street, Grosvenor-square—An improved construction of expanding table.—(Communication.)

Recorded November 12.

2622. Stephen Barker, Birmingham—An improvement or improvements in shaping metals.
2623. Francois A. D'Ande, 4 South-street, Finsbury, and Paris—Invention of a new metallic composition.
2624. Henry Kilshaw, Birch, near Middleton, and Richard Hacking, Bury, Lancashire—Improvements in machinery or apparatus to be employed in the preparation of cotton and other fibrous substances for spinning.
2625. John Gedde, 4 Wellington-street, Strand—Improvements in the means of consuming or otherwise preventing the escape of smoke from flues or other smoke vents.—(Communication.)
2626. John Gedde, 4 Wellington-street, Strand—Improvements in the manufacture of metallic compounds.—(Communication.)
2627. William Austin, 27 Holywell-street—Improvements in the manufacture of casks.
2628. Thomas De la Rue, Bunhill-row—An improvement in the manufacture of paper.
2629. William Austin, 27 Holywell-street—Improvements in apparatus for trapping passages into sewers or drains.
2630. Constant Busson, Paris—Certain improvements in finger-keyed musical instruments.—(Communication.)

Recorded November 14.

2631. John S. C. Hill and Edwin Cottrill, Birmingham—An improvement or improvements in stamps and presses, a part or parts of which improvements may be applied to other purposes.
2632. William Hadfield, Manchester—Certain improvements in looms for weaving.
2633. Sannel F. Cottam, Manchester—Improvements in machinery for spinning, doubling, and reeling cotton, and other fibrous substances.
2634. Henry Willis, Manchester-street—Improvements in the construction of organs and free-reed instruments.
2635. Alexander Cuninghame, Glasgow—Improvements in the manufacture or production of sulphuric acid.
2636. Matthew Gray, Glasgow—Improvements in welf forks for power-looms.
2637. Anthony F. Coubrough, Blansfield, Stirling—Improvements in leaching apparatus.
2639. William Smith, Manchline, Ayrshire—Improvements in ruling ornamental figures.
2640. Michael Fitzgerald, Sorrel Island, Clare—An improved means or method of communicating between different parts of a railway train.
2641. Charles De Bergue, Doggate-hill—An improvement or improvements in machinery or apparatus for removing patterns from moulds for castings.

Recorded November 15.

2642. John J. Catterson, Islington—Improvements in carriage springs.
2643. Charles E. Blank, Trump-street—Improvements in winding yarn into hanks.—(Communication.)
2644. John Liddell, Glasgow—An improvement or improvements in power-loom weaving.
2645. John Cameron and James Napier, Loughor, Glamorgan—Improvements in obtaining gold and silver from ores, alloys, or compounds, containing such metals.
2646. John H. B. Thwaites and William B. Herapath, Bristol—Improvements in the manufacture of quinine and other alkaloids.
2647. Adrien Delcambre, Paris—Improvements in machinery for distributing type.
2648. Joseph Fry, 19 Cannon-street West—Improvements in preparing solvents for india-rubber and gutta percha, and in rendering waterproof fabrics free from odour.

Recorded November 16.

2649. Peter A. Halkett, of the Albany—Improvements in apparatus for lifting and lowering ships and other heavy bodies, either submerged or otherwise.
2650. John Ellertorpe, Kingston-on-Hull—Invention for retarding and stopping railway trains and railway carriages.
2651. James W. Wayne, Gate-street, Lincoln's-inn-fields—Certain improvements in self-feeding furnaces.
2652. John R. Musgrave, Robert Musgrave, and James Musgrave, Belfast—Improvements in hot-air stoves.

2653. Philip Hill, Gravel-house, Coggleshall, Essex—Improvements in weaving plush and other piled fabrics.—(Partly a communication.)
2654. John Ronald, Paisley—Improvements in fixing colours on yarns and cloths.
2655. John H. Johnson, 47 Lincoln's-inn-fields, and Glasgow—Improvements in thrashing machines, and in apparatus connected therewith.—(Communication from Mons. Lotz, Nantes.)
2656. David Pratt, Birmingham—Certain mechanical arrangements for raising thimbles, the same to be worked by steam, water, or other power, thereby superseding hand labour.
2657. John Ferguson, Heathfield, Lanarkshire—Improvements in furnaces and fireplaces, and in the prevention of smoke.
2658. William F. Greenfield, Ipswich—Improvements in communicating from one part of a railway train to another.
2659. Thomas Jackson, Commercial-road, Pimlico—Improvements in the manufacture of hats.
2660. James Bristow, Bouverie-street, and Henry Attwood, Holland-street—An improved mode of constructing marine boilers.

Recorded November 17.

2660. Thomas Bourne, West Smithfield—Improvements in the construction of buckles.
2661. George Carter, Mottingham, Kent—Improvements in the construction of steam-engine boiler and other furnaces.
2662. John Clare, jun., Liverpool—Improvements in the manufacture of bar and sheet metals, in machinery connected therewith, and in the application of such metals to various useful purposes.
2663. George Dugmore and George H. Millward, Birmingham—A new or improved method of signalling or communicating between trains on railways.
2664. Solomon Abraham and Samuel V. Abraham, Lisle-street—Invention for communicating information or directions to persons in charge of railway trains.
2665. William Ashton, Manchester—Certain improvements in machinery or apparatus for manufacturing braud.
2666. John Benfield, Birmingham—Invention of a double-acting railway signal for preventing collisions or accidents on railways.
2668. Charles Burton, 457 New Oxford-street—Certain improvements in hand and draught carriages for common roads.
2670. Augustus J. Hoffstaedt, Albion-place—An improved mode of preparing the colour known as artificial ultramarine.
2671. Robert Griffiths, 444 Strand—Improvements in propelling vessels.

Recorded November 18.

2672. Patrick F. Keogh and William A. Wilson, Liverpool—An improvement in steam-engines.
2673. Percival M. Parsons, Duke-street, Adelphi—Improvements in railway and other carriages and vehicles.
2674. Alfred Guy, 32 Upper Rosomon-street, Clerkenwell—Invention of a portable water-closet, with water supply without the action of pump.
2675. Charles Fernibough and James Ferulough, Victoria Iron Works, Dukinfield, Chester—Improvements in machinery or apparatus for wringing or twisting, glossing, stretching, and drying silk, cotton, wool, flax, and other fibrous materials.
2676. Thomas Holmes, Pendleton—Improvements in ventilating drying stoves.
2677. James Gall, junior, Edinburgh—Improvements in electro-magnetic engines.
2678. Amédée F. Rémond, Birmingham—Improvement or improvements in the construction of steam boilers or generators.
2679. William Taylor, 16 Park-street, Gloucester-gate, Regent's-park—Improvements in anchors.
2680. James Melville, Roebank Works, Lochwinnoch, Renfrew—Improvements in printing textile fabrics and other surfaces.
2681. Jean B. Clavières, Paris, and 4 South-street, Finsbury—An improved mode of giving publicity.
2682. Moses Poole, Avenue-road, Regent's-park—Improvements in surface condensers, and in evaporators and heaters for steam-engines.—(Communication.)
2683. Patrick B. O'Neill, Paris—An improvement in the manufacture of perforated hutons.—(Communication.)
2684. John H. Brown, Aberdeen—Improvements in the manufacture of artificial skins.
2685. Henry B. Cottam, La Sussex-terrace, Hyde-park-gardens—Improvements in the construction of portable houses.
2686. James Rice, Foley-place, and William Matthews, Portugal-street—Improvements in instruments for taking and applying vaccine matter.
2687. Richard S. Norris, Warrington, and Ebenezer Talbot, Crewe—An improvement or improvements in the manufacture of iron.

Recorded November 19.

2688. James Harris, Hanwell—Improvements in apparatus for heating water and other fluids.
2690. Moses Poole, Avenue-road, Regent's-park—Improvements in breech-loading fire-arms, and in cartridges for use with such fire-arms.—(Communication.)
2691. William Austin, 27 Holywell-street, Westminster—Improvements in the manufacture of tiles and tubes.
2692. Ellis Rowland, Mossley, near Belfast—Improvements in apparatus to be applied to a railway truck or carriage, to enable a guard or person to sound a whistle, and when necessary to put such truck or carriage in motion independent of the locomotive engine.
2693. Thomas I. Dimsdale, Dublin—Invention for the use and preparation of certain solid and liquid substances for the defecation, purification, and decolorization of saccharine juices and sirups or solutions, and for neutralizing, decomposing, and absorbing noxious and fetid gases.
2694. John G. Potter and Robert Mills, Darwin—Certain improvements in the manufacture of carpets.
2695. Emanuel Wharton, Birmingham—Improvements in the manufacture of railway wheels.
2696. Henry Daniell, St. Anstell, Cornwall—Certain improvements in apparatus for drying clay.
2697. Richard F. Brand, South-terrace, Willow-walk, Bermondsey—Improvements in fire-arms and ordnance.

Recorded November 21.

2698. Walter H. Tucker and William R. Reeves, Tiverton—Improvements in locks.
2699. John Scott, junior, Greenock—Improvements in steering vessels.
2700. Henry Wilesworth, Newbury, Berks—Improvements in pistons.
2702. Sir John S. Lillie, 4 South-street, Finsbury—Improvements in apparatus for the production of carburetted hydrogen gas.—(Communication.)
2703. Robert J. Sibbald, Paddington, Edge-hill, West Derby—An improved mode of communicating from vessels to the shore, or from one vessel to another.
2704. Augustus Radcliffe, Chichester-place, King's-cross—An improved construction of glazier's diamond.
2705. John Cashmore, Bevis-marks—An improved mode of communicating signals on railways.

Recorded November 22.

2708. William Greaves, Leeds—Invention of an indicator alarm, applicable to railways and railway trains.
2709. Alexander Bain, Paddington—An improvement in cases for holding cards.
2711. Alfred Bird, Birmingham—Certain improvements in apparatus to be employed for the purpose of communicating signals on railway trains and railways, which improvements are also applicable to other similar purposes.
2713. Frederick Meyer, Paradise-street, Lambeth—Improvements in treating fatty and oily matters, to render them applicable for the manufacture of candles and night-lights.
2714. Frederick Levick, Cwm Celyn and Blaifa Iron Works, Monmouthshire—Improvements in machinery for raising coal and minerals from collieries and mines.
2715. Frederick Meyer, Paradise-street, Lambeth—Improvements in bleaching oils and fats.
2716. Charles Ramsay, North Shields—Improvements in ships' and other pumps.
2717. William Pegg, Leicester—Improvements in instruments for cutting out parts of garments and other articles, and in grinding and sharpening cutters for the same.
2718. Francis Arding, Albert Iron Works, Uxbridge—Improvements in machinery for cutting, splitting, and bruising vegetable substances.
2719. Benjamin Burleigh, Great Northern Railway, King's Cross—Improved railway crossings, as adapted to the double-headed rail and the ordinary rail and chair.

Recorded November 23.

2720. Henry R. Abraham, 11 Howard-street, Strand—Improvements in coffins and in hearses, and improvements in receptacles for coffins for their transmission.
2721. Charles F. Stansbury, 17 Cornhill—Invention of an apparatus to be attached to a drill for sowing grain or other seeds for the purpose of mingling guano or other pulverized manure with the grain or seed to be sown, and depositing it in the ground at the same time with the seed, thereby greatly diminishing the quantity of guano or other manure required to produce the best fertilizing effects.—(Communication.)
2722. John F. Empson, Birmingham—Improvements in the manufacture of wire.
2723. John Hill, sen., and John Hill, jun., both of Manchester—Improvements in machinery for winding, doubling, and spinning silk.
2724. Joseph Amos, Bristol—Improvements in preparing wood to be employed in the manufacture of casks and other vessels for containing liquids.
2725. John Timewell, Duke-street, St. James—Improvements in cutting or shaping materials to be employed in the manufacture of articles of dress.
2726. James Dilks, Parliament-street, Nottingham—Improvements in bands for hindling more effectually than heretofore, packets or parcels of lace, and other articles.
2727. Edward Wilkins, 60 Queen's-row, Walworth—An improvement or improvements in draining land.
2728. William B. Johnson, Manchester—Improvements in steam-engines.
2729. John D. Brady, Cambridge-terrace—An improved mode of, or a new arrangement of, straps for slinging knapsacks.
2730. Thomas W. Kinder, Dublin—Improvements in the construction of the permanent way of railways.

Recorded November 24.

2731. James Lovell, Glasgow—Improvements in the application of heat to various useful purposes.
2732. David Chalmers, Manchester—Improvements in railway breaks and signals.
2733. Hugh Mason, Ashton-under-Line, and John Jones, Manchester—Improvements in machinery or apparatus for doubling, twisting, and spooling woollen, cotton, and other yarns.
2734. Stephen Holman, Colney-hatch, Middlesex—An improved construction of double-action pump.
2735. Alfred V. Newton, 66 Chancery-lane—Invention of a novel construction of apparatus to be used as a chest-expander, and as a uterine or abdominal supporter.—(Communication.)
2736. Evan M. Richards, Swansea—Improvements in feed plates to be used for oxidizing lead, and refining silver and lead.
2737. Samuel C. Lister, Manningham, Bradford—Improvements in combing wool, cotton, and other fibrous material.
2738. Elmer Townsend, Massachusetts, U.S.—New and useful improvements in machinery for sewing cloth or other material.—(Communication.)
2739. William Jones, Kilney-cottage, Swansea—Improvements in the manufacture of bricks.
2740. Daniel L. Banks, Liverpool—Improvements in rotatory engines.

Recorded November 25.

2742. Davidson Nichol, Edinburgh—Improvements in the manufacture of envelopes.
2743. John Berry, Manchester—Improvements in the machinery or apparatus for manufacturing wire-fencing.
2744. William Calder, Glasgow—Improvements in the treatment and finishing of threads or yarns.
2745. William L. Brook and Charles Brook, jun., Meltham Mills, near Huddersfield—Certain improvements in preparing, dressing, finishing, and winding cotton and linen yarn or threads, and in the machinery or apparatus connected therewith.
2746. Alexander Drew, Glasgow—Improvements in ornamenting woven fabrics and other surfaces.
2747. John H. Johnson, 47 Lincoln's-inn-fields, and Glasgow—Improvements in carding engines, for carding cotton and other fibrous materials.—(Communication from George Wellman, Lowell, U. S.)
2748. John H. Johnson, 47 Lincoln's-inn-fields, and Glasgow—Improvements in the production of printing surfaces.—(Communication from Auguste Feldttrappe, Paris.)
2750. Auguste E. L. Belford, 16 Castle-street, Holborn—Improvements applicable to pens and pencils for writing or drawing.—(Communication.)
2751. Auguste E. L. Belford, 16 Castle-street, Holborn—Improvements in rotary engines.—(Communication.)
2752. Charles C. A. Grenier, 16 Castle-street, Holborn—Improvements in the preparation of paints for buildings and other uses.
2753. Enoch Wilkinson and William Rye, Oldham—Improvements in power-looms.
2754. Emmanuel Barthélemy and Tony Pettigrew, Upper John-street, and Jean P. Bourquin, Newmau-street—Improved means of ornamenting glass.

Recorded November 26.

2755. Joseph Wormsld, Vauxhall, and George Pollard, York-road, Lambeth—An improved pipe wrench.
2756. William C. Moat, Strand—An improved truss.
2757. Joseph Stenson, Northampton—Improvements in the manufacture of iron.
2758. Georges E. Gazagnaire, 16 Castle-street, Holborn—Improvements in the manufacture of nets for fishing and other purposes.
2759. Hippolyte Couette and Jean M. Hammerbacher, 16 Castle-street, Holborn, and Paris—An improved machine for washing linen and other textile fabrics.
2760. Jules Roth and Henri Danner, 16 Castle-street, Holborn—An improvement in cards for carding.
2761. Auguste E. L. Belford, 16 Castle-street, Holborn—Certain improvements in strain-mill saws.—(Communication.)

2762. Louis Cornides, 4 Trafalgar-square, Charing-cross—Invention for combining gelatine with certain other substances, and colouring the same, so as to produce various objects capable of resisting atmospheric influences.
2763. Thomas Chambers and John Chambers, Thorncliffe Iron Works, near Sheffield—Certain improvements in kitchen sinks.
2764. Joseph S. Rousselot, Nimes, France—An improved application of magneto-electricity for driving machinery, and for neutralizing the impulsive force of machinery in motion.
2765. Joseph M. H. Perodeaud, 35 Rue Godot de Mauroy, Paris—An improved mode of treating peat for the conversion of the same into an artificial coal, which may be used in that state, or afterwards reduced to coke.

Recorded November 28.

2766. William Pritchard, Clerkenwell—Improvements in buffers for diminishing the shock in the collision of railway trains.
2767. John Walsley, Accrington, and John Ingham, Blackburn, Lancaster—Improvements in looms.
2768. Prix C. J. B. Sochet, 4 South-street, Finsbury, and Paris—Improvements in obtaining motive power by means of heated gases.
2769. Robert H. Nicholls, Bedford—Improvements in hoeing and otherwise cultivating land.
2772. Alexander Macomic, 6 Percy-street, Marylebone—Invention of an ornamental piece of furniture, shaped like a vase, constructed to contain or form a writing and drawing desk.
2774. Samuel Hurrell, New North-street—Improved machinery for measuring and winding or rolling fabrics.

Recorded November 29.

2775. Patrick Kelly, West-street, Drogheda—An improved apparatus for cultivating, preparing, and treating land, and for sowing seeds.
2778. Auguste E. L. Belford, 16 Castle-street, Holborn—Improvements in fire-arms.—(Communication.)
2779. Joseph Moore, Lincoln—An improvement in or addition to ploughs.
2780. James A. Manning, Inner Temple—Improvements in the treatment of sewerage and other polluted liquids, and the products thereof.

Information as to any of these applications, and their progress, may be had on application to the Editor of this Journal.

DESIGNS FOR ARTICLES OF UTILITY.

Registered from 16th Nov., 1853, to 9th Dec., 1853.

Nov. 16th,	3530	H. J., and P. Nichol, Regent-street—"Paletot or coat."
18th,	3531	Edward Morris, Birmingham—"Sugar-mould."
—	3532	Chas. Symons, Prince's-street, Fitzroy-square—"Table-bedstead."
22d,	3533	A. R. Cunningham, Kensington—"Candlestick."
23d,	3534	George Brewer, Hackney, and Charles Suffell, Long-acre—"Flexible tube self-acting level."
26th,	3535	J. Yates, Whitechapel—"Blocking-machine."
Dec. 2d,	3536	J. Paterson, Wood-street—"Balmoral tie."
3d,	3537	T. Barnes and W. Johnson, Lancaster—"Bobbin."
7th,	3538	J. Lingard, Sheffield—"Knife-handle."
8th,	3539	E. Reynolds, Derby—"Link-motion."
9th,	3540	Dent, Alcroft, & Co., Wood-street—"Commercial purse."
10th,	3541	E. Green, Wakefield—"Cbinney-top."

TO READERS AND CORRESPONDENTS.

KUKLA'S GALVANIC BATTERIES.—We are requested to state, that the author of this paper, as given in our report of the British Association proceedings, p. 123, for November last, is Mr. Waleen, of Duke Street, Adelphi.

A. PARSEY.—We must again refer to the definition of perspective, given in our review in October. It has not been shown to be incorrect. A valid argument against the use of the vertical plane should demonstrate that such use does not accord with the definition. What Mr. Parsey advances is unsatisfactory in this respect.

HUCK'S FEED APPARATUS FOR BOILERS.—In reference to Mr. Willoughby's remarks on this contrivance, Mr. Huck writes as follows:—"There are several minor details in my apparatus which I omitted, simply because they were of themselves clearly obvious. Without in any way wishing to detract from the merits of Mr. Willoughby's invention, I have to state, that I experimented upon an arrangement on the same principle as his about two years ago." Mr. Huck accompanies his notes with a sketch, which we have not engraved, as it is identical in principle with that of Mr. Willoughby.

J. M.—If our correspondent will favour us with drawings and actual details of his improved plans, we shall be glad to consider them.

R. D. K.—Mr. Cockings, 26 Anne-street, Birmingham, is the proper party to apply to.

E. B.—Next month.

J. C.—The engravings are being made.

NEWSPAPER STAMPING MACHINES.—We find that the introduction of the penny stamp into the form at the Times Office, was first officially suggested by Mr. E. Hill, in 1848, and the idea was then formally entertained by the authorities; but its practical adoption at that time was stopped by legal difficulties. These difficulties, however, whether real or imaginary, have since been overcome, and the question being revived some months ago, the plan was finally put in operation. The mechanical stampers in use at Somerset House are also the invention of Mr. E. Hill. (See our illustrated notice of them in April last.) Thus much by way of correction of our last month's note, p. 220.

C. J. W., Norwich.—Our correspondent is quite at liberty to carry out the plan he proposes, as the detail in question cannot be validly claimed.

D. H. L., Buenos Ayres.—We are at a loss as to his meaning. What is the object to be gained by this system of classification, and on what principle are the divisions arrived at?

A. C.—There is no modern work on this special manufacture. See *Ure's Dictionary of Arts, &c.*

STEAM BOILER INCrustATIONS.—A correspondent wishes to know what have been the results of the use of muriate of ammonia in steam boilers for the prevention of incrustations.

J. B., Deptford.—(Practical Draughtsman.)—Our friend is slightly fastidious. The plates are printed on damp paper, which shrinks on drying. This will occasion the discrepancy complained of. Further, we don't find J. B.'s table correct. He makes the scale on Plate XXII., 3 per cent. short, and that of fig. 7, Plate I., 1 per cent. short. On comparing these two together, we do not see the slightest difference between them. It is possible, however, that his copy may have shrunk rather more than usual.

RECEIVED.—"Practical Remarks on Railways and Permanent Way," by W. B. Adams—"Hints to Intending Gold Diggers and Buyers," by G. F. Goble—"The Safety Lamp, for the use of Coal Miners," by T. Y. Hall—"Chemistry, Theoretical, Practical, and Analytical, as applied and relating to the Arts and Manufactures," by Dr. S. Muspratt.

THE CLAIMS OF ORIGINATORS.



TATESMEN hold that there is no quality more precious, in a national point of view, than individual speculation—not on the Stock Exchange, but mental speculation, looking through the present to that which is looming in the future. There are pseudo-statesmen who disregard this, and treat all such speculators as visionaries, and proclaim their belief in nothing but the "practical"—not the possible and useful practical, but the actual existing practice, which is often not useful,

and most commonly not so useful as some other practice yet to come. Such men proceed on the assumption that all useful knowledge has been gained, and that all proposers of change are positive nuisances to society. They are the Galileo crushers of modern times, but they are perhaps honest in their belief.

There is yet another class of men, sent into the world for some wise purpose, who act as a drag-wheel on all progress but their own, and, at the same time, are unconsciously impeding themselves. "There is no speculation in *their* eyes." Arriving at a position in society without originality, they would fain check all originality which they cannot appropriate to themselves. This is the class of people who, from time to time, seek to destroy the law of patents, and to keep up the law of partnership—who, in short, try, by all means in their power, to make themselves permanent in their practice, and prevent all others from attaining a similar practice, save by their own processes.

The word patent is generally understood, or rather misunderstood, to mean a mere monopoly. But it means more. A patent of nobility is a monopoly, but nobody disputes it, for it harms no one, and is supposed to be conferred for some personal merit. But there are patent monopolies, which are so in the invidious sense, a patent *in-equity*—that is, an open wrong, taking rights without corresponding duties—such monopolies as are granted to Spanish governors—in short, the right of levying black mail. The third kind of patent is the monopoly granted for fourteen years, in consideration of making patent or clear to the public, an original speculation of an inventor's mind in a practical form. Against this last kind of patent there testified before the Committee of the House of Lords, during the last agitation for the amendment of the law, eight persons—two of them sugar refiners, two civil engineers, one barrister, one merchant, one lieutenant-colonel, and one member of Parliament.

When witnesses give testimony in a court of justice, the credibility of their testimony and the possibility of bias are duly weighed. When opinions are given, it is essential to inquire into the position and capacity of the opinion-giver. In a question of laws affecting national progress, we should be inclined rather to the opinion of a statesman than to that of a civil engineer. The position of the statesman cannot be affected by considerations of whether one individual or another prospers by invention; the position of the engineer may be seriously affected—it may be a question of rivalry even.

There are two opposite opinions given—by a statesman who ranks amongst the highest minds of the community, John Stuart Mill; and an engineer who has prescribed the mode in which many millions of the money of the community has been expended. Mr. Mill says—"If the system of patents were abandoned for that of rewards by the state, the best shape that this could assume would be that of a small temporary tax imposed, for the inventor's benefit, on all persons using the invention. No limit can be set to the importance, even in a purely productive and material point of view, of mere thought. Intellectual speculation must be looked upon as a most influential part of the productive labour of society."

No. 71.—Vol. VI.

The engineer says—"If there were no patent laws, I think a man would think over his invention a little, get it into a shape to do him credit, and then, if he had a good master, he would show it to him; and, if he thought he could make anything of it, he would give the man a pound or two, which would he really earned, instead of hundreds being dreamed of, but never touched."

That is to say, the speculative man, with his ideas, should be kept, like a milch cow, to be drained at the option of the master, and seek in the condition of a helot, for the master's benefit and repute. This engineer would have kept Mr. Watt chained up in a corner, to be used when required.

This engineering opinion is based on no logic whatever, but it very fairly represents the existing practice. People work for money and repute, and occasionally for philanthropy. And repute is but another word for money. The sham is set up, and gains the repute from the unthinking, and also the money, and the reality is pushed into a corner. This it is that explains Mr. Whitworth's report of the greater progress in the American Union. The original man here buys and keeps his situation on which his bread depends, by paying away his brain in black mail. In the States, the original man exchanges away a portion of his brain for a moneyed partner, and springs to the state of masterdom. It is this oppression—this forced sale of brain for a mess of pottage, like buying land from the Indians with beads—that drives across the Atlantic many an intelligent workman with a master mind, to swell the growth of American invention.

It is a very common thing for men of narrow mind who hold a position, to be desirous of attaining fame for qualities which they do not possess. It is almost ludicrous to watch them, and observe to what small and contemptible things they will lay claim when they know there is no recorded disproof—how, in an uncertainty, they will lie by, waiting to claim success, or to throw the obloquy of failure on a subordinate. Why is this? Simply that they are misfitted to their occupations, and live in a state of unhappy anxiety, in fear of being tripped up. Aptitudes are born with a man, and there is no greater curse through life than when the brain of a lawyer is forced along the grooves of a machine.

The objectors to patents are—manufacturers who possess a monopoly in their great capital and established trades. They can keep down any competition, save that of a better article they are not allowed to make, by reason of a patent monopoly in a rival's hands, who can undersell them, or give a better article. Had they the power, the public would not obtain the better article. They would not have improved themselves, and would have impeded others. A Manchester manufacturer once remarked, "We never make improvements till profits get to be wire-drawn."

So much are patents hated by capitalist manufacturers, that a practice has obtained of late years of seeking to neutralize them, by buying them up and quashing them—depriving the public of their use, if use they have. They thus obtain a monopoly, not for, but against the public benefit. They would rather not have had the patents at all. The member of Parliament who gave evidence against patents was precisely in this position. Without the protection of a patent, no one would have embarked in opposition to a powerful company, and the company buys off the opposition and competition, to the loss of the public. More than one public company is in this position; and the allegation is, that they are obliged to buy up the patent, in order to be enabled to use some minute portion. But the numbers bought prove that not the utility was desirable, but the opposition dreaded.

There are other classes of persons—generally in easy circumstances—who object to patents as an injustice to the public and to individuals. They say that principles are public property, and ought not to be monopolized. True, but the monopoly is granted in consideration of making patent and useful, an unnoticed principle, by its application.

But it is granting a monopoly to A which B might have discovered to-morrow, or has already discovered in private! The answer to this is, that A has first made it patent, and is the legal owner. But it is an injustice, and ought not to be! If so, neither ought there to be a copyright in books.

But books do not embargo principles! They embargo forms of words containing principles, and for three generations; the patent is only for fourteen years. But anybody may write other words to the book principle! And, save when it is the enunciation of a new principle, any one may set a new form of machine to the principle.

Still it is monopoly.

True; and almost all property is a monopoly. The title of this *Journal* is a monopoly. The word "*Times*" is a monopoly of a large value—if any one doubt it, let him try the result of printing it on a broad sheet, and he will soon get notice to "clear out of those diggings." Various hieroglyphics on manufactured iron are a monopoly, as the Chancellor will quickly show, if any one use them without the owner's leave. The throne is a monopoly—regiments and ships are monopolies to colonels and captains. The House of Lords is a monopoly, and the House of Commons is monopolized by men with long purses, or strong connections, or great power of talk. The universities are monopolies. Churches and chapels are monopolies. Land and water, and everything above and below them, are monopolies; and all of these monopolies are maintained, and will be maintained, because the public believe that by these monopolies society benefits. Why, then, should not individual mental property in a patented invention be a monopoly also?

There is only one reason. Showing that it is not beneficial to the public. But it is a thing the public did not possess before, and therefore it was not theirs. If they value it, it is a proof that service has been rendered. A very common proof of this is, that a patent not popular is never followed by imitative patents; but a really useful patent, known to be so by its ready sale, is instantly followed by a host of pseudo improvements.

But, it will be said, other persons than the patentee might have found it out, and given it gratuitously to the public.

This is merely begging the question. The attention of the imitative patentees is only drawn to it by its successful use. A contemplated patent and a secured patent are equally valueless in the market, till public opinion has stamped them. They are like the new books taken round to all the booksellers, who refuse them in turn, till some one tries his chance, hit or miss—the public gives a favourable verdict, and then the whole town is in a furor. The inventor is a "schemer," as the author is a fool, till cash seems forthcoming from their brains, and then the schemer becomes a mark for antagonists, whose previous contempt has grown into envy. Numberless patents have been as useful the day they were promulgated as at any subsequent period; yet it is notorious that three-fourths of the time pass away before they get into use. And what stops them getting into use? Not the public; but the opposition of party interests, which, in many cases, finally compound for a share of the profits—the black-mail which inventors pay to society.

But then, again, it is objected that patentees get enormous profits at the expense of the public. In nine cases out of ten, the objectors would be found to be those desirous of sharing in the profits. But, as a mass, inventors are not such men. There are many blanks to one prize. But what if an inventor does get a £100,000 prize, or double that? How does the public suffer, unless he be a spendthrift? The inventor is the public saviour instead of somebody else, out of the wealth he himself has created. And to what purposes will he apply these savings? Not to horse-racing! No!—to putting in practice still newer inventions to the still greater service of the community. Who should better know how to employ wealth than the creator of it?

We have written thus far to show that the inventor is the benefactor of the public; but he is also the benefactor of the capitalist, who would go

on competing with his neighbours, till, by competition in profit, none were left for want of new things to work in.

"But," it has been said, "inventors cannot help inventing more than hens can help laying eggs, and so the public will get the inventions without payment." This is coolly selfish enough, but it is an argument lacking basis of support. The eggs may be laid, but it will be in holes and corners, and they will not be hatched. The large capitalist will not embark in a set of experiments, such as most new things need, unless he has some security that he shall reap where he has sown. He will not work for his neighbour's benefit, and the only trifling things that will be improved in will be kept as mysteries and secrets as long as possible. Factories would become as fortresses with no strangers admitted, and a wholesale system of stealing patterns and methods from each other would prevail, as it did before the registration act, precisely as the Egyptian fellahs steal each other's unripe crops, to the general loss of all around.

Driven out of this, the objectors to patents take refuge in the assertion that patents do no good to inventors, and that, if successful, they are ruined at law by infringers. This is another begging of the question. The invention is proved good and useful by the fact of the infringements; and yet, because the law is inefficient to protect the mental property which the law has conferred, it is taken as a matter of course that the inventor must sit down under his wrong and grievance. It does not seem to enter into the objector's mind, that the plain and simple remedy is to alter the law and make it effective.

"But," continue the objectors, "if patents are made certain and safe from risk of litigation, so many will be taken that they will interfere with the processes of industry."

It is quite clear they do not interfere with existing processes of industry, and if the public dislike to use the improved process, or consider the inventor of it unreasonable, they can wait till the fourteen years are expired. There is another point. Now that patents are cheapened, they are taken in larger numbers; but out of those numbers a large portion are duplicates or reinventions of what has been done before, taken in ignorance, because there has been no correct means provided for ascertaining what really has been done. Had a cyclopædia been published, or a well-digested plan embodying all the existing patents, many a fancied new invention would have been set aside, and the inventor's money saved. We should possess a record of much rubbish, but also of much that is most valuable.

There can be no doubt that a community without originating minds would be very rapidly reduced to the effete condition of the Chinese Empire; and everything tending to impede original progress will have more or less this effect. The abolition of patents, and the continuance of the present law of partnership, would leave no chance to original minds in a lowly condition, and they would largely emigrate to the United States, or any country where their mental property might be recognized. We might not feel it at once, but assuredly the next report of Mr. Whitworth would mark a still greater change fatal to England's ascendancy. That country must be the most powerful that is at the head of civilization, and is provided with all the latest improvements in the arts, both of peace and war; and it is men—intelligent men—by whom these arts are promoted. We have reached a position hitherto unequalled, in spite of our disabilities; but if, presuming on what we have, we take it for granted that all is attained, and that we may now throw aside the class of men who essentially have made us what we are, grave questions will thenceforth be mooted. The possessors of property in the natural sense—i. e., the existing possessors of the land and the waters, and all that thereon and therein is—bold, as they think, an inalienable right; but no man-made laws can abrogate the laws that nature made in the beginning. Man, in the aggregate, is a product of the soil, and has an aboriginal right in the soil. Individual ownership can only be based on the claim to make that soil beneficial to the community. If the material

property be all entailed, and the property in original brains be made to merge in common stock for the benefit of the material owners, they will do well first to examine all the hearings of the question, and they will find that it is a *one-sided* socialism in the objectionable sense, and that, after making common stock of the brains, it will not be long before common stock will be made of the material land and water, and all that thereon and therein is, in the form of a *many-sided* socialism, in which the original brains will claim the land from the hereditary possessors on the ground of making a better use of it.

For those who hold power undisturbed, it will be well to take care that the originators shall have their legitimate spheres of action. Let them not be made to feel that there is no part in the system for them. The free circulation of society upwards and downwards is its health. Stop the circulation, and fever will be generated—a stagnation that will end in paralysis.

There is no profession so poorly paid as that of originators—in every branch of thought or imagination. Yet origination is the living soul of the community. It is not a healthy condition of society, when the large prizes of life, and the power they confer, are chiefly gained by the charlatan class. While the philosopher contemplates the spectacle, the passionate hearts of the natural leaders of men brood over it.

W. BRIDGES ADAMS.

THE LAW OF PATENTS FOR INVENTIONS IN THE KINGDOM OF SPAIN.

A royal decree, signed the 27th March, 1826, established the following regulations:—

Every person, to whatever class or country he may belong, who proposes to establish, or does establish in Spain, a machine, apparatus, or a mechanical or chemical process, or operation, which is new, wholly or in part, or which has not hitherto been established in the same manner or form in the kingdom, shall have the exclusive ownership and use of it; and to insure that ownership and use to the author, there shall be delivered to him a royal patent of privilege. The patent, however, will be no guarantee of the novelty or utility of the invention. Patents shall endure for five, ten, or fifteen years, at the option of applicants, in respect of original inventions, but for imported inventions they shall be limited to five years. A patent for five years, in respect of an original invention, may be afterwards prolonged for five more years; but patents for ten or fifteen years cannot be prolonged.

To be entitled to a patent for an original invention, it is necessary that the invention shall not have been brought into use, either in Spain or elsewhere, out of the kingdom. When it has been practised abroad, but is new in Spain, a patent for an imported invention can be applied for. The inventions, of which models or descriptions shall have been deposited in the Royal Conservatory of Arts at Madrid, cannot be the objects of patents until three years have elapsed since their deposit, and then only patents for importations will be permitted.

The exclusive privilege granted by a patent for an imported invention applies only to a manufacture within the kingdom, and does not authorize the importation from abroad of things there manufactured.

The petition for a patent must not comprise more than one invention, and it must be accompanied by a plan or model, with a description of the invention, specifying the mechanism or particular process which is the subject of it. This description must be clear and precise, so that there may be no doubt as to the identity of the invention, nor as to the particular part of it which is claimed to be new.

Before the patent is issued, the applicant must produce a receipt, proving that he has paid to the Royal Conservatory of Arts the sum imposed by Government on the patent. This sum varies in the following manner, according to the length of the privilege awarded, viz.:—Five years, 1000 reals (about £10. 10s.); ten years, 3000 reals (about £21); fifteen years, 6000 reals, (about £31. 10s.) On a patent for an imported invention, however, 3000 reals are payable.

A registry of patents is kept at the Royal Conservatory of Arts, and is open to the inspection of all applicants.

Patent rights are transferable and bequeathable in the same manner as other personal property.

A patent becomes void in the following cases:—If the patentee does not apply for the royal document, within three months after the presentation of his petition; if he shall not carry his invention into effect within a year and a day after the date of the patent; if there should be a cessation for the same space of time in working the invention; if it should be proved that the invention had been in use within the kingdom previous to the date of the patent, or had been described in printed books, or in engravings, paintings, models, plans or descriptions, to be found in the Royal Conservatory of Arts; if the invention was previously known abroad, and the patent has been taken out in respect of an original invention.

Persons guilty of infringing a patent are liable to confiscate all the machines, apparatus, and manufactured articles made in violation of the patent, and to the payment of a fine equal to three times the value of the confiscated articles.

THE CUT NAIL MANUFACTURE. MESSRS. DANKS & WALKER'S NEW MACHINERY.

The manufacture of cut nails by machinery was originated by the Americans, who have for a long time carried on an enormous trade in the article, exporting large quantities to different foreign markets. Since its introduction here, the trade has rapidly grown up, more particularly during the last fifteen years, which is about the time that cut nails with heads have been made in England. Prior to this date, cut brads—or nails completely finished at one blow, being in general mere wedges and shoe-hills—had been in use here for a long time, probably forty or fifty years. Until about twenty years back, these nails were made by hand presses.

At the present time, there are in Birmingham, and in the busy metal-working district of Wolverhampton, about a dozen large manufactories of this kind, besides several minor establishments.

Leeds, with some of the Lancashire towns, also possess several small manufactories. The weekly produce in this country is calculated at 300 tons—a vast mass of solid metal to be worked up into such small articles. Amongst the more prominent English firms is that of Messrs. J. Walker & Co., Junction

Fig. 1.

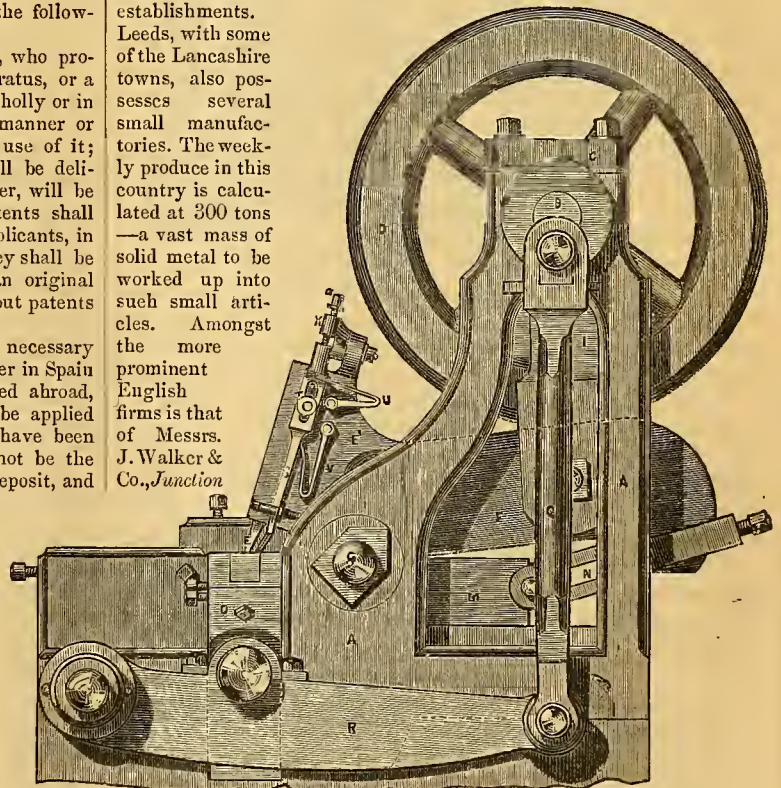

Works, Wolverhampton, where the recently patented machinery of Messrs. Danks & Walker is now at work. In these machines, the blank for the nail is made to turn over during its descent from the strip which is being used as the raw material of the nails. This movement is effected by means of the "spring gauge," which is set upon a swivel joint, and is made to descend through a greater space than the cutter itself, so as to cause the blank to perform a quarter of a revolution during its descending traverse from the crude strip of metal to the grooved dies used for shaping the nail head. The result of this operation is, the

production of a nail which has its opposite sides shaped to the same angle of inclination, whilst the fibres of the metal are kept in a sound and compact condition, instead of being disintegrated, as usually occurs in the ordinary process of manufacture. Fig. 1 of our illustrations is a side elevation of one of the improved nail-making machines complete, as fitted up with the new guage and turn-over piece. Fig. 2 is a corresponding front view of the machine. Fig. 3 is an enlarged side view of the cutter edge and guage point detached; and fig. 4 is a plan of a slip of sheet metal, showing the way in which the blanks are primarily cut.

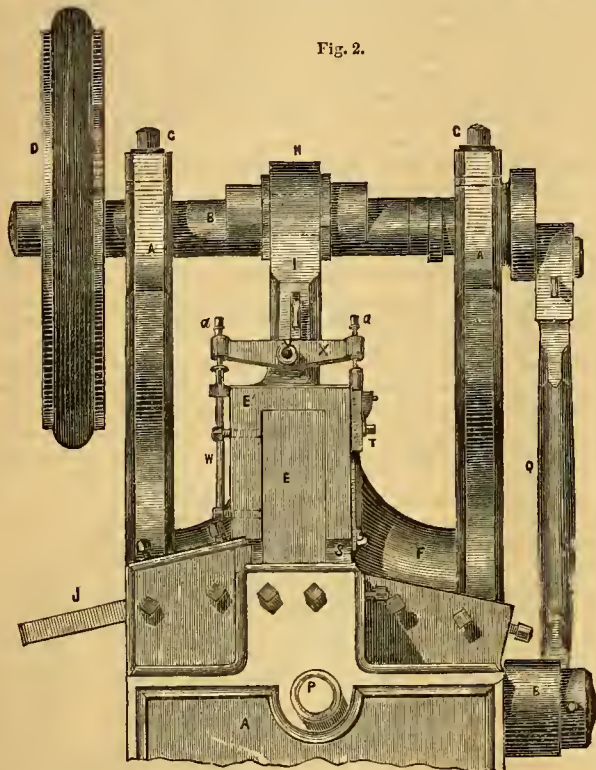
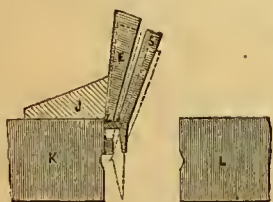

Fig. 2.

The framing of the machine consists of a single casting, a. The driving shaft, n, is carried in bearings, c, at the top of the framing, and on this shaft is a fly-wheel, d. The upper cutting-tool, e, is fixed by adjusting screws in the head, e', of the heavy bent lever, f, which vibrates upon centres, g, in bearings in the framing, and is actuated by the crank, n, of the driving-shaft, b, and connecting-rod, i. The lower or stationary cutter, j, is secured in its place by set-pins, and it rests upon the stationary gripping die, k, so that its vertical

Fig. 3.



cal face is in the same line with the face of the gripping die, k. The opposite gripping die, l, is adjusted in the slide, m, which is worked by the end of the lever, f, to which it is connected by a short adjustable link, v. When the nail is gripped by the dies, k, l, a head is formed upon it by the lever punch, o, vibrating on the centre, r, and actuated by the driving-shaft, b, through the connecting-rod, q, and side-lever, b.

Fig. 4.



The width of the nail blank is determined by the guage, s, attached by a slot and pin, r to the cutter head, e'. The motion of this guage, s, is regulated by the two blade springs, v, v, the upper one, v, of which acts on a pin fixed in the guage, and tends to raise it, whilst the other one, v, presses the guage against the nail blank. On the other side of the cutter head, e', is a vertical rod, w, carried in suitable eyes, and arranged to strike some fixed part of the framing when the cutter descends. This necessarily forces up the rod, which, being in contact with the end of a lever, x, vibrating on a centre, r, on the cutter head, the other end of which lever is similarly in contact with the top of the spring guage-piece, s, forces the spring guage-

piece, s, down, and causes it to turn the nail blank, z, a quarter round, as shown in dotted lines in fig. 3. In this position the blank, or partially formed nail, descends to the recesses in the gripping dies, k, l, and has a head formed upon it, as before described. When the cutter head rises, the spring, v, elevates the guage to its normal position. The lever, x, is fitted with screws, a, at its two extremities, by means of which screws the stroke of the guage may be effectively adjusted. It will be obvious to the practical man, that the downward motion of the guage, s, may be effected by various other mechanical contrivances. Thus, the nail blank may be turned by a spring turn-over piece, similar to the one already described, and used in connection with the spring guage, as commonly used. In feeding in the strip of metal, from which the nail blanks are to be cut, it must be turned at each stroke, so as to use up the metal equally, because the blanks are tapered in form. This is represented in fig. 4, the inclined cross lines representing the successive cuts, showing that the broad ends alternate with the narrow ones or points.

It must be evident that the nails made in this way are far superior to those hitherto used; and hence we may look for some impetus to our trade in this respect; for the quality of the nails made at the majority of the English works is at present so far inferior to that of the United States' productions, that the English makers find themselves quite shut out from many foreign markets, in spite of the much higher price charged by the Americans. The general character of the machinery employed in this country for cutting nails is of a very low class, both the design and workmanship being exceedingly rude. Indeed, we believe that there are not more than four English makers who can supply really good nails at all times.

Large quantities of zinc and copper nails are made by the "cut" process, for sheathing and slating, the cut nail having, to a very great extent, superseded the use of wrought nails for most purposes. But the wrought nail is still made in very large quantities, by hand and hammer, in the neighbourhood of Dudley. For work where nails are required to clench, cut nails are obviously inadmissible, as they are not sufficiently fibrous and ductile; otherwise, it seems not improbable that the use of wrought nails would be still more interfered with.

PATENT LAW AMENDMENT ACT, 1852.

A third set of rules under this Act has just been issued. Those important to the public generally are given below, verbatim:—

"Every application for Letters Patent, and every title of invention and provisional specification, must be limited to one invention only, and no provisional protection will be allowed or warrant granted where the title or the provisional specification embraces more than one invention.

"The title of the invention must point out distinctly and specifically the nature and object of the invention.

"In the case of all petitions for Letters Patent left at the office of the Commissioners after the 31st day of December, 1853, the notice of the applicant of his intention to proceed for Letters Patent for his invention shall be left at the office of the Commissioners eight weeks at the least before the expiration of the term of provisional protection thereon, and no notice to proceed shall be received unless the same shall have been left in the office eight weeks at the least before the expiration of such provisional protection; and the application for the warrant of the Law Officer and for the Letters Patent must be made at the office of the Commissioners twelve clear days at the least before the expiration of the term of provisional protection, and no Warrant or Letters Patent shall be prepared unless such application shall have been made twelve clear days at the least before the expiration of such provisional protection; Provided always, that the Lord Chancellor may in either of the above cases, upon special circumstances, allow a further extension of time, on being satisfied that the same has become necessary by accident, and not from the neglect or wilful default of the applicant or his agent."

It will be seen from the last rule, that, practically speaking, the six months given to an inventor to determine whether he will proceed with his invention or not, is reduced to four—*as*, if the notice to proceed is not given before the expiration of four months, the patent cannot issue.

It appears that the Patent Office are at length carrying out the provisions of the *Patent Law Amendment Act*, by printing and publishing the whole of the specifications and drawings as they are filed. We have obtained several of these copies; and as some criterion of the prices charged, we may state that the cost of a specification of ordinary length, with one sheet of drawings attached, is about sixpence. An office copy of such a specification, to be obtained from the Enrolment Office, costs at least £3. If these specifications can be produced at an early date from the time of filing, and proper indexes to them are published, an inventor will possess greatly increased facilities for ascertaining the novelty or otherwise of his proposed plans.

The number of patents applied for appears to suffer no decrease. From the 1st of January to the 13th of December, of the past year, no less than 2,900 patents were applied for. Considerable dissatisfaction is, however, caused by the unnecessary delays arising with the law officers—as from the mass of duties which those gentlemen have to perform, it is perfectly impossible that they can spare time to attend to the business relative to patents coming before them.

GOLD: ITS PROPERTIES, COMBINATIONS, TESTING, EXTRACTION, AND APPLICATIONS.

Gold, so precious in its character of an exchangeable commodity, is of inverse significance in the arts—an industrial sphere, where it is beaten by iron and brass; yet, so great was the thirst for this empirically precious metal, about the middle of the second century of the Christian era, that the most monstrous attempts were made to obtain it by artificial means. Hence arose those wild conceits and hallucinations embodying the erroneous doctrine of alchemy—leading onward numbers of skilled men to spend their lives and squander their fortunes in the vain endeavour to obtain the philosopher's stone, and by it to transmute baser metals into gold, besides arresting all our bodily infirmities into the bargain.

It was vulgarly believed, that by some such magical aid Arterpius was enabled to spin out his earthly days to the extent of 1,025 years; and as the then strong body of alchemical philosophers mingled their theories with the doctrines of mythological visions of all the various sects then in existence, no difficulty was met with in obtaining converts to the foolish belief. Indeed, the nobility and gentry of England became so infatuated on the subject, that Government interposed for the prevention of such egregious waste of substance in searching for the universal solvent; and the following short act—as Lord Coke has termed it—was passed in reference to the movement in the reign of the fourth Henry:—

“None from henceforth shall use to multiply gold or silver, or use the craft of multiplication; and if any the same shall do, he shall incur the penalty of felony.”

Gold is one of the elementary substances, and, with the single exception of platinum, it is the heaviest body in nature—its specific gravity being 19.258, or very nearly twenty times the weight of its bulk in water.

In making the thin gold sheets, known as gold leaf, so extensively used for overlaying various surfaces, a number of thin rolled plates of gold are hammered between pieces of animal membrane, technically known as “gold beater's skin.” A single grain of gold thus fully worked out, covers $56\frac{3}{4}$ square inches, the absolute thickness of the metal being no more than $\frac{1}{882000}$ of an inch. But this is by no means a test of the ultimate malleability of the metal, for some copper is always added to harden the comparatively soft gold.

Gold-lace makers use a fine wire, which is drawn from a gilt ingot of silver, the primary gold coating remaining perfect during the severe reduction which the ingot necessarily undergoes in being extended into fine wire. The final thickness of the wire coating is no more than 1-12th of that of ordinary hammered gold leaf.

In gilding copper surfaces by the amalgam process, the upper surfaces are first well cleaned by tripoli, and then immersed in a dilute solution of nitrate of mercury. A thin coat of mercury is thus precipitated on the copper, and an amalgam of gold is then thinly spread over the mercury coat. The articles so treated are now removed to an oven, and the heat therein being raised to 660°, the mercury is volatilized, leaving the gold alone upon the copper surface. When cooled down, the articles are rubbed with a piece of soft leather, and a beautifully gilded surface results. On the large scale, the furnaces or ovens are so constructed that the mercurial fumes are condensed and collected for further use. Brass is gilded in the same way, and so is iron, through the medium, however, of a copper coating. The iron is first dipped in dilute sulphuric acid, and then rubbed dry with whiting, to brighten it—the upper coating being subsequently applied by immersion in a solution of sulphate of copper. Steel is gilded by the ethereal solution of gold, made by adding to a solution of chloride of gold a quantity of sulphuric ether. When the mixture is well stirred, it is allowed to settle for a few seconds, when the ethereal solution separates from the mass, forming a well-marked stratum at the top of the mixing glass. A piece of silk, satin, or ivory, wet in a solution of chloride of gold, and placed, whilst wet, in a jar containing hydrogen gas, or sulphurous acid gas, soon glistens with all the brilliancy of gold, from the reduction of the solution to the metallic state. If the chloride solution is employed as an ink for drawing a device upon the silk, the delineation alone will, of course, be in gold, whilst the ground of the silk remains white. Again, if the silk is wetted with phosphoric ether, and the ether allowed to evaporate, the subsequent dipping of the silk in a solution of chloride of gold produces a golden coat.

In gilding glass or porcelain, a permanent film is obtained by using a composition of gold powder and borax ground in a mortar, with gum-water added to it. This mixture is laid on with a camel's-hair pencil, and the glass or porcelain article being put into an annealing oven, the

gum is burned off, and the vitrification of the borax cements the gold down to the treated surface.

These are the original modes of gilding—now, for the most part, superseded by the elegant modern process of electro-gilding. In this process, the article under treatment is connected with the anode-electrode, or positive wire, of a Smee's or Grove's battery, and placed in a glass cell containing a solution of cyanide of gold; and a plate of gold is connected with the cathode-electrode, or negative wire, and placed in the solution alongside the article to be gilded, but not in immediate contact with it. The electrical action of the battery then decomposes the solution, and the contained gold is precipitated upon the metal article at the anode, whilst the liberated cyanic acid acts upon the gold plate at the cathode, dissolving a portion of the solid mass, so as to keep the solution at a uniform strength. Leaves of plants, fruit, silk, indeed almost any surface, may be coated with gold, by giving such surface a conducting power. To do this, the article is first wet in a solution of phosphorus, prepared by dissolving phosphorus in bi-sulphuret of carbon or sulphuric ether. When the liquid evaporates, the article is connected with the anode of the battery, the glass cell being filled with a solution of sulphate of copper, with a copperplate attached to the cathode-electrode placed in it. A film of copper is thus quickly deposited upon the article when it is ready for the gold-plating process.

Plumbago, rubbed upon the article to be plated with a brush, may be substituted for the phosphorus; but the conducting power of the lead is inferior to that of phosphorus.

Gold unites with most of the metals by fusion. With silver it forms a compound of a pale tint, much paler than might be anticipated from the quantity of silver employed. Copper unites with gold, forming an alloy much harder and more easily fusible than pure gold—it is this alloy of which our current gold coins are made. The addition of a very little tin renders the mixture brittle. Lead destroys the ductility of gold, brittleness being produced by the addition of only a single grain to the ounce. With iron, gold forms a greyish compound, capable of magnetic attraction. Mercury unites with it in all proportions, forming an amalgam liquefiable by heat, and cooling into crystals. Zinc produces brittleness and a beautiful whiteness; and the same changes attend the admixture of antimony, arsenic, bismuth, manganese, and nickel. Equal weights of zinc and gold produce a fine grained alloy, used for telescope specula.

The metals which diminish the ductility of gold, here arranged in the order in which they affect the ductile property, are bismuth, lead, antimony, arsenic, zinc, cobalt, manganese, nickel, tin, iron, platinum, copper, and silver. Mr. Hatchett, to whom we are indebted for this arrangement, considers the first three to be of nearly equal effect. Hydrochloric acts but slowly upon gold; but, when mixed with nitric acid, it becomes a powerful solvent of the metal. Chromic acid, added to hydrochloric, produces a dissolving mixture also; but nitro-chloric acid (aqua-regia) is the most convenient of known solvents. Gold, immersed in this fluid, produces effervescence, and the solution is of a yellowish tint, tinging animal substances a deep purple, whilst evaporation gives chloride of gold in fine topaz-coloured crystals. Precipitation of the metal from its solvent is produced in many ways. Lime and magnesia give a yellowish precipitate; the same occurs with potash and soda, an excess of the alkali acting again as a solvent. This precipitate appears to be a pure oxide, soluble in nitric, hydrochloric, and sulphuric acids. Ammonia readily gives an orange precipitate, which detonates with a loud report when gently heated, or treated frictionally. Gallic acid furnishes a red precipitate, soluble in nitric acid, when a beautiful blue is produced. Most of the metals precipitate gold from nitro-chloric acid. Mercury, copper, iron, zinc, and bismuth, throw it down in its metallic condition; and silver and lead precipitate it of a dull purple hue. The precipitate afforded by tin is termed the purple precipitate of cassius, and is extensively used in enamelling and painting. The sulphurets have alike precipitating power—the alkali unites with the acid, and the gold falls in combination with the sulphur, which may be driven off under a moderate heat.

To determine whether an article is really gold or not, a slight scraping of it is put into a test-glass, adding a little nitric acid. If the scraping is gold, the acid will have no effect; but, to make sure of the point, it is usual to add some hydrochloric acid, and the treated metal will then be dissolved with effervescence. A portion of the liquid being then put into two test-glasses, to one of the quantities a few drops of a solution of gallic acid are added, and to the other a little chloride of tin. If gold is present, the precipitate, in the first case, will be reddish, and in the latter, a fine purple. Instead of scraping the tested article, it is usual to rub its edge upon a piece of unglazed porcelain or ground glass, covering the mark so made with nitric acid, and following the procedure already described.

Gold is largely diffused over the earth, but in many localities it occurs in such minute and widely-scattered fragments, that it will not pay for working expenses. On the other hand, portions of California and Australia, as all the world knows, have proved splendid exceptions. Fig. 1

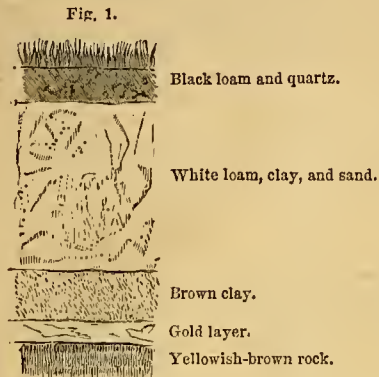

of our diagrams will afford some idea of the Australian gold field strata, representing what the diggers call a "surface gullet," gold being met with at about 16 feet from the surface. Fig. 2 is a section of a "deep gullet," the ore being 36 feet down. The ore, or the auriferous earth, is of a light colour, largely mixed with quartz pebbles, very tenacious, and difficult to wash. It lies upon a yellowish-brown rock, of a rotten texture, known as fixed slate, whilst higher up, above the gold, the strata present igneous

features. The gold itself also gives the impression of having been melted, resembling drops of melted metal as poured into sand, the indentations being visible even upon the smallest particle of the gold, when microscopically examined.

Fig. 3 is a microscopical view of a fragment of Australian gold, as magnified 700 times. The Transylvanian auriferous lamellar ore contains, in addition to gold and quartz, silver, lead, copper, tellurium, oxide of manganese, and sulphur. About a year ago, great excitement arose at the Cape of Good Hope, in consequence of the discovery, near Simon's Bay, of a substance said to contain a large proportion of gold. Dr. P. G. Stewart, of Simonstown, sent a quantity of this suspected mineral to the writer for his analysis. It was found to possess a glistening, yellow, semi-metallic lustre; but when submitted to the searching powers of the microscope, its metallic brilliancy disappeared, especially when viewed by transmitted light, when it had a darkish grey colour, being in thin semi-transparent plates. Fig. 4 is a sketch of the microscopical appearance of small particles of it. It is unacted upon by nitric acid, and hence, no doubt, arose the error in taking it to be gold. In reality, it is merely mica, highly coloured with the oxide of iron. The following is the

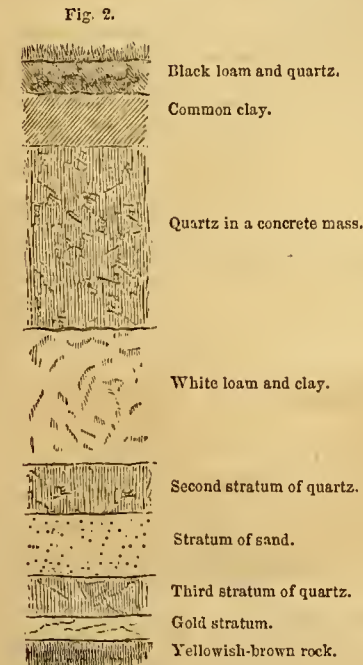

writer's analysis:—

Silica,	46
Alumina,	23
Potash,	14
Oxide of Iron,	16
Manganese,	1

100

The sulphurets of iron ore and copper pyrites have also often been supposed to be gold, but the distinction is very easily made out. If gold, scraping will betray a peculiar softness. Its retention of colour under the blowpipe is another favourable proof; but if it burns, leaving a scoria behind, it is a sulphuret either of iron or copper. If of iron, the magnet will distinguish it; but it may be a mixture of iron and copper. To ascertain this, some of the scoria is treated in a test-glass, with a few drops of hydro-chloric acid, when an effervescing solution is obtained. A

little of this liquid is then transferred to another glass, and one of the glasses must now have added to it a few drops of ferro-cyanide of potassium—liquid ammonia being added to the other. If iron is present, the ferro-cyanide glass will become blue, the iron combining with the



cyanic acid of the ferro-cyanide of potassium, and producing cyanide of iron—Prussian-blue. If copper is there, the glass will be of a reddish-brown tint, cyanide of copper being formed. If iron and copper are present together, the two metallic precipitates will be the result, and a purple tint arises from the intimate mixing of the red and blue colours. The glass to which ammonia was added will be changed to a brownish tint, if iron is present, and to a fine blue, if copper is there.

By a modification of Klaproth's method of analysing gold ore, a determined weight of the ore is reduced to powder in a mortar, and digested at a moderate heat with nitro-chloric acid. An effervescence now takes place, and the black colour of the ore disappears; the solution is then poured upon a filter, the residuum being again digested with hydro-chloric acid, and the whole filtered again. In a short time, crystals of the chloride of gold are deposited in the fluid and upon the filter paper: these are treated by pouring boiling water upon them until they are dissolved, when only a portion of quartz and a little sulphur remain. The sulphurous ingredient in the ore unites into a coherent mass, and is consequently easily removed from the earthy residuum, when it is placed upon a calcining test, and submitted to a low heat, when the loss of weight will indicate the quantity of the contained sulphur. The calcined substance is then dissolved in hydro-chloric acid, adding to it the foregoing solution. That portion of the matrix which consists of white grains of quartz is then dried and weighed, and mixed with four times its weight of carbonate of potash, and melted to vitrification. On breaking the crucible, a few grains of silver will be found; and these particles, on being collected and weighed, furnish an approximate idea of the quantity of silver contained in the ore. The nitro-chloric solution is then concentrated by evaporation, and, when cold, crystals of chloride of lead are deposited, and these are separated from the solution by filtration, when they may be reduced to the metallic state by heat. After the concentrated solution is thus freed from lead, it is diluted with a little water, alcohol being added as long as any precipitate falls. The mixture is then placed upon a filter,edulcorated with alcohol, redissolved in hydro-chloric acid, and again precipitated with caustic soda. This precipitate is oxide of tellurium.

To ascertain the proportion of gold, the liquid from which the tellurium is obtained is put into a retort, when the alcohol is distilled off, and nitrate of mercury is added to the concentrated fluid until the brown precipitate no longer appears, and until the white precipitate succeeding the brown one ceases to change its own colour. The mixture is then placed in a warm atmosphere, when the white precipitate, which is produced by adding the nitrate of mercury in excess, gradually disappears. The heavy brown powder, which falls to the bottom of the glass, is the oxide of the gold sought for; and when collected and fused in a crucible, with nitrate of potash, this gives a bead of pure gold. The liquor from which the gold is precipitated is now saturated with carbonate of soda at a boiling heat, and a copious grey precipitate is formed, turning to a blackish-brown by ignition. When digested in hydro-chloric acid, with the addition of a solution of carbonate of ammonia, carbonated oxide of manganese is thrown down, which, when collected and dried, is of a greyish colour. The blue liquid of the last process is super-saturated with sulphuric acid, by which it is rendered colourless, when a plate of polished iron is introduced into it, and it is placed in a warm atmosphere. Under these circumstances the plate becomes coated with copper, the proportion of which is at once ascertainable by weighing the iron plate before and after deposit in the fluid. When the quantity of gold alone is required, the two last processes are unnecessary.

THE SOCIETY OF ARTS EXHIBITION.

II.

CAVANAGH'S ADJUSTING LOCK SPINDLE—WATERPROOF CANVAS HOSE—DRAINING LEVEL—GOLD ORE CRUSHER—POLYTINT PRINTING MACHINE—SEMI-TUBULAR TRANSVERSE RAILWAY SLEEPERS—BOAT LOWERING APPARATUS—COMBINED REFRIGERATOR AND FILTER—DIOPTRIC REFRACTORS FOR LAMPS—DISTRIBUTOR AND MIXER FOR GRAIN—TRUSS FOR OVEN CROWNS—NICOLE'S ROTATORY ENGINE.

Mr. Cavanagh, of Frederick Mews, Connaught Square, one of whose designs has already been illustrated in this *Journal*,* shows his "tubular adjusting lock spindle," one form of which we have delineated in figs. 1, 2, and 3. This spindle consists of three parts, the outer portions being each provided with a stud, arranged to fit into holes or recesses in the

Fig. 1.

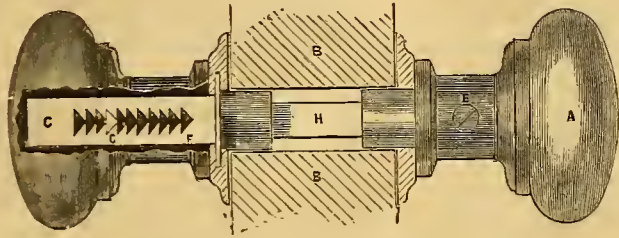

inner central part. The formation of the spindle in three pieces, which constitutes the novelty of the design, so arranges it that, on the removal of the centre piece, the other two pieces collapse or fall together, and disengage the studs from their holes; and after this the spindle may be set to any length by inserting the studs in other holes. It is thus easily

Fig. 2.

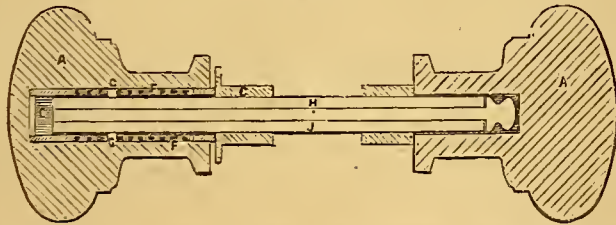

adapted to any thickness of door—a most important feature in house-fittings of this class. Fig. 1 represents the spindle with one side or end in section; fig. 2 shows it in complete longitudinal section at right angles to fig. 1; and fig. 3 is a detached view of one of the side pieces.

Fig. 3.



Here, A, are the usual hollow turning knobs, B being the thickness of the door through which the spindle passes, taking into the latch of the bolt or lock in the usual manner. C is a hollow metal rack shank inserted within the knob, for the purpose of giving increased strength to the adjusting spindle, and obviating the necessity of extending the mortice in the lock or door. Set screws are fitted at E, for fixing the knobs to the shanks; F are the rack openings, and G the adjusting studs. The three separate pieces of which the spindle is composed are indicated by the letters, H, I, J.

Mr. E. Weir of Bath Place, New Road, exhibits a useful "Waterproof Canvas Hose," in lengths of 120 feet, with gutta percha union-joint connections. This hose—which is not more costly than common sewed canvas hose, and is only half the cost of leather—is not subject to the rapid destruction usually arising from alternations of moisture and dryness, or from the acids of manures. Noxious fluids may also be passed through it without allowing any perceptible odour to escape, so that tanks may be pumped off, and the contained fluids conveyed to a distance without inconvenience.

The same exhibitor's "Draining Level" is a simple arrangement of a spirit tube upon a tripod stand, as an improvement upon the common plumb-line, which is so liable to deranging influences in open exposed situations. An important feature in this contrivance is its self-telling

* Page 223, Vol. IV.

capacity—no calculation whatever being necessary on the part of the observer; for when the air-bubble has been brought to its dead-level central position, the actual amount of inclination of the ground is shown by an index-hand upon a segmental scale.

Messrs. Nourse & Co. of Cornhill, here bring forward Berdan's Gold Ore crushing, washing, and amalgamating Machine, as noticed by us in October last. The exhibited model is one-eighth the real size of the machine, the larger ball of which weighs two and a half tons, and the smaller one, one ton. This combination of mechanical crushing with the action of heated mercury, seems to be most successful. The same exhibitors also show Messrs. Sands & Cumming's Brick Machine, capable of producing 20,000 bricks per day, with a single working horse—going through the processes of tempering and moulding at one operation.

The "Polytint Printing Machine" of Mr. H. C. Gover, of Prince's Street, Bedford Row, is a very complete mechanical colour-printing apparatus, resembling, in its general features, the "Rotatory Printing Machine" of Mr. S. Sharp.* It consists of a series of plattens, or pressing surfaces, according to the number of colours the machine is intended to print, arranged equi-distantly round a common centre. The colours are printed simultaneously on a suitable number of sheets of paper, the sheets being moved successively from one block to another. Beneath the plattens are placed the blocks, or surfaces to be printed from, each block being supplied with a different coloured ink by a suitable apparatus. There is a rotating table, on which are fixed the tympan for carrying the paper, there being as many tympan as there are blocks. In order that each sheet of paper may, in succession, receive an impression from all the blocks, the rotating table, after each action of the plattens, carries the paper from each block to the next, and at each such action a perfect impression is withdrawn, which has successively received the various colours; the first block is supplied with a fresh sheet of paper, and the previously supplied sheets of paper, still in the machine, are each advanced one stage. Unlike the letter-press machine to which we have referred, where super-imposed cylinders are used for giving the necessary printing pressure—constituting it a pure "cylinder" machine, Mr. Gover's press is an effective combination of the "platen" and rotatory systems. The impressing action is derived from a central vertical shaft, carrying a cam which actuates in succession a series of knee joints, one above each platten, for giving the necessary pressure. It is easy to see that accurate registration is secured by this plan; and, as it is self-inking and feeding, a high rate of production is obviously attainable.

Messrs. Day & Laylee, of Barrow Hill, Ashford, have examples of their "Semi-tubular Transverse Railway Sleepers," in wrought and cast-iron, affording a favourable instance of the application of metal to structures of this nature. The wrought-iron sleeper is stamped and pressed out of boiler plate, and the cast-iron seating for the rail is in two parts, with a flange to rest upon the arched top of the sleeper, the rail being secured in its seat by a wooden key, which is the only fastening required.

Fig. 4.

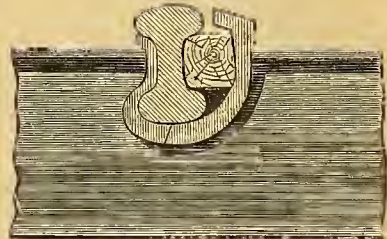

The sketch, fig. 4, is a longitudinal section of part of a sleeper, with the rail in transverse section upon it. The cast-iron sleeper is in two parts connected by wrought-iron bars running across the space between the rails. The seating or chair is cast with the sleeper, and the rail is keyed in just as we have sketched it. With this plan, the bearing surface being within three inches of the top of the rail, the whole depth of the ballast is available for the stability of the road.

A "Truss for supporting the Crowns of Ovens," by Mr. Thomas Day, Upper Mall, Hammersmith, exhibits a satisfactory mode of preventing the expansion of the brickwork in these erections. It is an admitted fact that, after being some time at work, the durability of ovens is affected, not so much by positive working wear, as by some part of the mass giving way; and it is by no means uncommon for an oven to require fresh support, either by tying or shoreing up, after having been built but a few years, especially if the erection is above the earth's surface. This arises from the crown being necessarily very flat, and a heavy weight of brickwork being required on the top to retain the heat, a powerful pressure is produced on the sides, forcing out the weakest part. But by Mr. Day's contrivance, the crown is capable of standing un-

* Page 133, Vol. I., *Practical Mechanic's Journal*.

assisted, whilst it is deprived of its "spreading" influence, the truss acting on the crown in the same manner as a hoop on a cask. The furnace may be taken out and repaired without injuring the structure.

Fig. 5 represents a plan for lowering ships' boats, by Mr. G. F. Russell, Thames Chambers, Adelphi. By this arrangement, although the boat possesses the great advantage of resting her whole weight upon the keel cranes, A, yet the very act of lowering at once disengages her from them without hoisting, at the same time projecting the boat several additional feet from the ship's side, as the link, B, straightens out, and as both the pendants, after passing over the heads of the cranes, lead to one barrel of the winch, both ends of the boat must be lowered together. When near the water, one man can disengage the boat fore and aft, by a single hand lever. The winch is placed flush with the bestaunchions inside the bulwark, and is fitted with a brake. One man on board can lower the boat when full; or, by a lanyard fastened to the brake handle, a man in the boat can lower it by himself. The same tackle is always ready for hoisting the boat, and the winch being placed at a distance from the cranes, which turn inboard, the boat can easily be brought on deck.

Fig. 5.

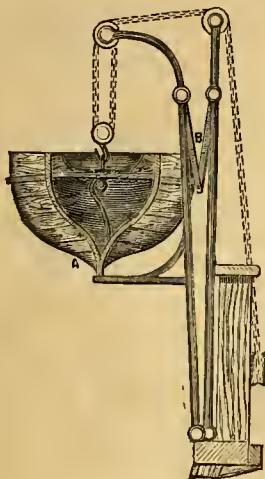

The "Combined Refrigerator and Filter," represented as open, in fig. 6, is a most useful contrivance. It forms an ice-safe, with a compartment for a filtering apparatus, and a passage for the flow of the filtered water in immediate contact with the ice, so that the water may be drawn off iced. There is also a support for the ice, so that the water formed therefrom may be readily collected and withdrawn. It is by Mr. T. D. Mills, of Vernon Street, Pentonville.

Fig. 6.

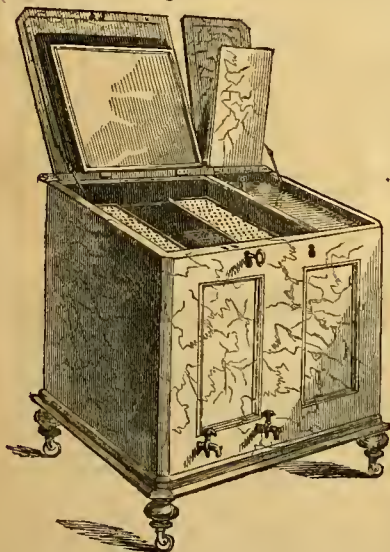

The "Dioptric Refractors," for artificial light of all kinds, by Mr. Boggett of Lisle Street, Leicester Square, present a very elegant practical application of a well-known philosophical principle. Here, a prismatic lens on each side of the light—as an argand gas-burner, for instance—produces the appearance of three perfect flames.

Messrs. Davison & Horrocks, of Mark Lane, contribute their "Distributor and

Mixer," for treating all kinds of granular matters requiring drying. This is a modification of the common screw conveyer, such as is in use in grain mills, the screw threads having ribs or minor blade-pieces attached, so that, in revolving, these pieces turn over, and mingle, or disintegrate, the particles being traversed through. As arranged for such a purpose, the screw conveyers, with their encircling tubes, are built in tiers inside a rectangular case, and the spindles of these conveyers, being geared to work in concert, the grain is passed through the series, by being fed into a hopper on the top of the case, and thence passed back and forward from one conveyer to the other through tubular end connections, until finally discharged at the bottom of the case.

The "Rotatory Engine" of Mr. Adolphe Nicole, of Dean Street, Soho, presents a mode of obtaining a direct rotatory action from the combination of two cylinders—an outer and inner one—the outer one being fixed, whilst the inner one acts as the revolving piston. The piston is constantly eccentric to its outer case, so that there is a constant lunate space between the two, as in Barclay's and other engines. But the present plan differs from these in the fact, that the piston, although carried upon

a crank, does not entirely rotate. Fig. 7 is a longitudinal section of the engine, and fig. 8 is a transverse section corresponding. The outer stationary cylinder, A, has within it the revolving piston, B, working on the crank-pin, C, of the main shaft, D. The stop or steam abutment, E, is fixed to the external cylinder, and passes through the opening, F, of

Fig. 7.

Fig. 8.

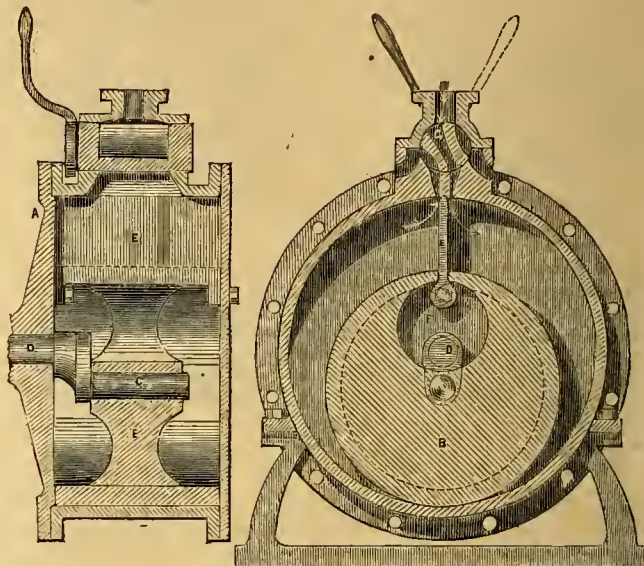

the inner cylinder or piston. At G is a four-way cock, which, being turned to the right or left, allows the steam to enter the cylinder on either side of the stop, for the reversing action. The working movement possesses some elegance. As the shaft with its working crank goes round, the slot in the piston works back and forward over the stop, the space, F, allowing of the play of the inner end of the stop, as the piston partially revolves upon its pin.

RECENT FRENCH INVENTIONS.

"SAFETY PAPER" FOR PREVENTING FORGERY—PLATINA PLATING—ELECTRIC SMELTING—CAVÉ'S COMPENSATING MARINE ENGINES—ORNAMENTAL INCrustATION IN GLASS.

One of the last curiosities of French invention is the "safety paper"—*marque incontestable ou genre de fabrication de papier inimitable*—of M. Millet. In our language, this scheme would be designated simply as a plan for the prevention of forgery, the object being the production of irregular marks upon paper intended for bank-notes and other negotiable documents, so as to place the greatest difficulties in the way of the forger copyist. So far, the highest ingenuity has been able to do but little for the prevention of forgeries of this class; and the tediously reiterated labours of "Messrs. Perkins, Bacon, and Petch," and their more modern imitators, in the engraving of the words "Five Pounds" an

Fig. 1.

Fig. 2.

Fig. 3.

Fig. 4.

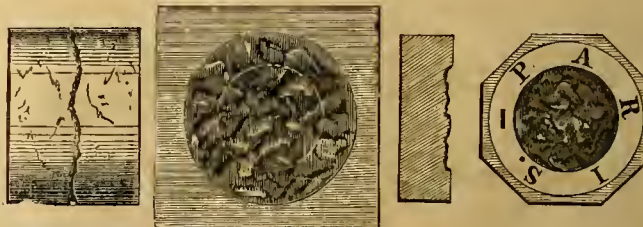

almost infinite number of times, on an infinitesimally small scale, have merely given the forger a little more trouble, without adding anything to the honest man's security. Such a principle of prevention is bad; for whatever a skilled artist or engraver can execute, can be equally well copied by the clever forger. He must not work by rule; for, as M. Millet remarks, although "distinguished engineers, artists, and engravers have produced most remarkable results, as well with regard to complexities

of design as to precision and beauty of workmanship, yet it has always been possible to imitate the marks, in spite of their multiplicity of lines, because, inasmuch as the devices were produced by the hand of man, they must necessarily admit of imitation in artistic lauds." Reasoning on this point, it occurred to M. Millet, that in order to manufacture a paper which it would be impossible to counterfeit, no mechanical means, nor yet any direct handiwork, should be employed in producing the distinguishing figures, as such work must always be more or less regular and geometrical, and, therefore, susceptible of imitation in the hands of a clever artist. M. Millet, therefore, employs what may be called "chance" figures—such, for example, as the chance irregularities of surface consequent upon the fracture of a piece of metal. In carrying out this idea, he obtains the nucleus of his design from the transverse fracture of a block of metal, wood, or coal, fig. 1; and then, placing between the corresponding irregular surfaces of such fracture a piece of lead, gutta percha, or other impressionable substance, he obviously produces corresponding irregular marks on each side of such soft material, as at fig. 2. Then, supposing a portion only of such fractured surface to be made use of in the intended design, certain ciphers or devices, moulded in wax, are added to the primary figure, forming a matrix or mould, from which a reverse impression is obtainable in plaster, or any soft plastic substance, as in fig. 3—fig. 4 being the transverse section. From this, again, any required number of metal or composition moulds may be made for actual use, in impressing their device upon the wire-cloth of the frame in which the paper is made, and thus each sheet of paper is indelibly marked with the figure of the original fracture, and the word "Paris," or whatever word or cipher, may be added to it. Should a clever artist succeed in imitating the irregularities of the mark, he would still be very far from producing an accurate copy, inasmuch as he has to follow, not only the various outlines, but also the light and shade effect.

M. Savard, an extensive worker in precious metals at Paris, has recently introduced "platina plating," for works where a non-oxidizable metal is required. He produces, in fact, a compound metal, consisting of leaf platina, strengthened by being joined to copper, brass, silver, or steel, and he thus secures a cheap and strong substance, possessing all the peculiarly valuable properties of solid platina. The plating process may be performed either with or without the aid of heat. When heat is employed, the contact surfaces of the platina and the baser metal are made perfectly clean, and then laid together face to face, several such combinations being piled into one mass, with a sheet of iron between each series, if copper is used as the base metal, the iron being first rubbed with garlic to prevent adhesion. The pile is then placed between two external plates of iron or steel, beld together by wire binding, and is deposited in a furnace until it attains a red heat. It is then removed and subjected to a powerful compressing apparatus, which is more effectual if made to work with a percussive action, and this treatment secures the perfect adhesion of the two plates of each series. The compound sheets may afterwards be rolled and worked up, just as if they were entirely composed of one metal. When heat is not used, the inventor effects his object by the simple process of rolling under great pressure.

The electric light has found a novel application at the hands of M. G. A. Pichon, in smelting ores. In carrying out this

Fig. 5.

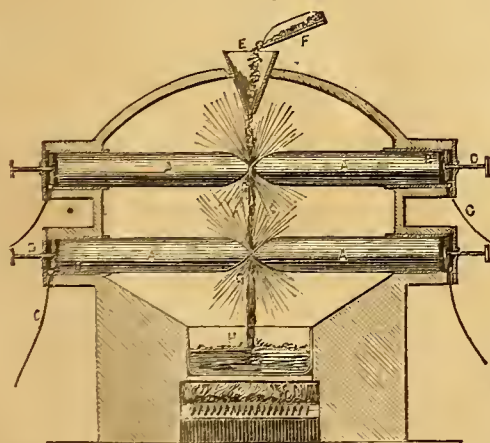

the light fusion takes place, and the metal, with its contaminating slag, falls down into a heated receiver beneath.

Fig. 5 is a vertical section of the apparatus, containing a duplex electric system. The electrodes, a, which are prisms of about two feet square and nine feet long, are tapered off at one end for about two feet, whilst their opposite ends are enclosed in metallic caps, b, each of which has a small ring for connection to the conductive wires, c, of the battery. A screw spindle, d, is also fitted into each cap, for the purpose of advancing the electrodes as the combustion goes on.

In the crown of the containing oven is fixed a hopper, r, supplied with ore from the inclined trough, f, and the metallic mass is thus dropped through the lights at g, into a receiver, u, kept hot by a furnace beneath, when the slag separates from the molten metal, on account of the difference in the specific gravities of the two masses.

M. Pichon also proposes a modification of this plan, wherein one of the electrodes is tubular, and the ore is supplied through it. The electric power is produced by an electro-magnetic apparatus, like that used in this country for electro-gilding.

M. Cavé, the eminent Parisian engineer, is now introducing a new form of steam-engine, embodying a plan of compensation for the working

Fig. 6.

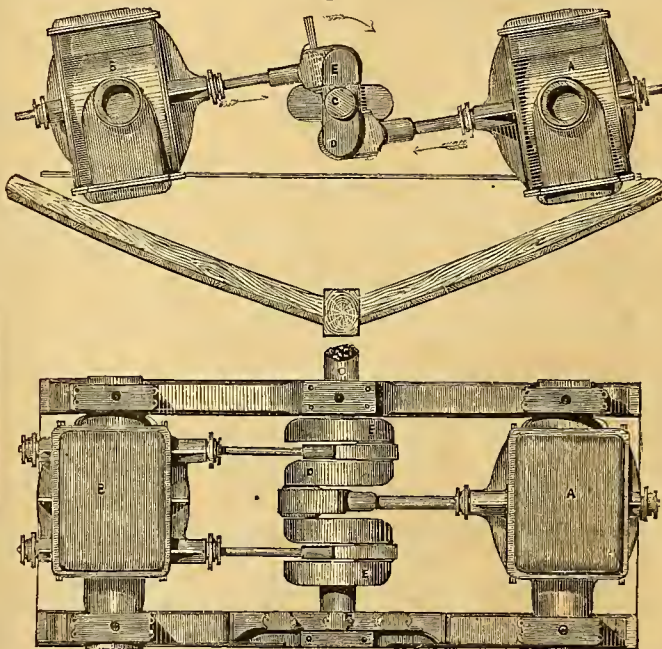

Fig. 7.

strain of the crank action, and thus enabling the engines to be driven at a much higher velocity than is possible with the ordinary unbalanced arrangement. The contrivance, which is a simple crank and connecting-rod arrangement, is represented in figs. 6 and 7, as applied to marine purposes. Fig. 6 is a sectional elevation of the four-cylinder engines of a screw steamer, two of the cylinders only being actually seen; and fig. 7 is a plan of the duplex cylinder arrangement, forming one engine; the other pair of cylinders, with the intermediate crank-shaft and air-pumps, being broken away. The steam cylinders, a, b, in each case, are disposed opposite to each other, or right and left athwart-ship, the screw-shaft, c, being run along the keel line, between each pair of cylinders. The piston actions of the two cylinders are conveyed to the main shaft through a triple crank, d, e, e, the centre crank, d, being set diametrically opposite to the other two, e; and, of course, in a double marine engine, like the present, the opposite duplex engine has three similar cranks disposed at right angles to those in the figures. The piston of the cylinder, a, has a single rod connected directly, as in a common oscillating engine, with the central crank, d; whilst the piston of the opposite cylinder, b, has a pair of parallel rods respectively jointed to the outside cranks, e. To give a steadier bearing, the piston rods, in both cases, work through stuffing-boxes in the external ends of the cylinders. The valve motion, working slide valves of the ordinary kind, is so arranged that the pistons are made to traverse in opposite directions, as indicated by the arrows; hence, as one piston pulls just as much as the opposite one pushes, the action on the crank-shaft is similar to that of the hands upon the double lever of an auger or wrench, and the shaft, therefore, turns without undue pressure upon its bearings.

A novel system of ornamentation in glass, porcelain, and metal, has lately been patented in this country, by Mr. W. Johnson, C.E., on behalf of M. Gellée, of Paris. It is by a species of incrustation, or inlaid work, that the invention is worked out, pieces of glass of different colours being laid one upon the other, and united into one mass by heat; such composite masses are then softened in an enamelling furnace, and a device—as a rose, for instance—is then impressed upon the upper surface of the glass by a die. Supposing a layer of purple glass is, in this case, laid upon a blue layer, the die will impress the purple glass with the body of the blue layer, at the same time cutting out the glass to the intended shape of the brooch or other ornament to be made. The design so produced is in *intaglio*, and the process is continued upon it by grinding flat, and removing the superfluous glass, or that which has not been impressed by the relief surface of the die. The piece of glass is then polished and finished, when it presents a perfectly smooth face, formed by a blue ground, with a purple flower in it. Instead of this process, a similar effect may be produced by impressing the figure on a piece of glass of one colour, and then uniting a second colour by heat.

By another modification, the figure is punched out of one colour, and inserted into a corresponding hole in another; any number of colours being thus incrustated at pleasure.

SCOTT'S CONTINUOUS-ACTION SCREW PURCHASE FOR SLIPS.

(Illustrated by Plate 143.)

Mr. Scott, whose excellent arrangements of hydrostatic keel-blocks and swivel-arms for slips have been fully illustrated in our Plate 73, Vol. IV., has here introduced a still more valuable adjunct for the shipbuilder's slip and dockyard. This contrivance is a very elegant mechanical combination for working slips by an easy continuous drawing action, whereby vessels may be drawn up from the water, and again let down into it by a traverse movement, at once powerful, steady, and convenient. Fig. 1 on Plate 143, is a longitudinal section of a portion of a slip, showing the purchase in side elevation complete. Fig. 2 is a corresponding plan of the purchase.

The essential feature of the traction apparatus is, a large compound or right and left threaded screw, *A*, laid down at the head of the slip, and carried in end bearings, *B* *C*, set on a timber base, forming the upper surface of a massive foundation, *D*. The outer, or higher projecting end of this screw, carries a large spur wheel, *E*, by which it is actuated through a train of gearing in connection with the steam-engine, or other prime mover of the establishment. Each thread of the screw—the junction of the two threads being at the exact longitudinal centre of the spindle—carries a massive nut, *F*, *G*, both nuts being expanded laterally, to such an extent as to fit in between the longitudinal guide-frame pieces, *H*, bolted down to the foundation and to the end-bearing pedestals of the screw. The upper, or right hand nut, *G*, has attached to it a pair of parallel traction rods, *I*, running down one on each side of the screw, and at the same axial level. These rods work freely through eyes in the left hand nut, *F*, as well as through similar holes in the bearing, *B*, and pass thence to the large duplex horse-shoe hook or link, *J*, *K*, to which they are jointed by link discs at *L*. This arrangement forms one of the hauling movements for the ship carriage. The other is made up of another pair of parallel traction rods, *M*, which are connected to the left hand nut, *F*, passing thence through eyes in the pedestal, *B*, outside the first pair, and through pedestal guides, *N*, bolted to the timber base of the incline, and they terminate in a larger duplex hook, *O*, *P*, to which they are jointed by disc links, *Q*, as before.

The hauling chain, *R*, is formed of flat iron links, in alternate sets of three and four pieces, jointed by transverse pins, like the chains of a suspension bridge. The lower end of this chain is connected in the usual way to the ship carriage on the slip incline, running down to the water at *S*, the upward course of the chain being in the line of the main traction screw, *A*, over which it passes, upon a line of supporting pulleys on a timber stage, *T*, to the coil-drum, *U*. The connection of the traversing nuts, *F*, *G*, and their duplex hooks, *J*, *O*, with the hauling chain, is by means of square shoulders, *V*, formed on the links at each joint eye, and contrived so that the upper pieces, *J*, *O*, of the traction-hooks may fall over, by their own weight, and catch upon the shoulders at each change, whilst the corresponding lower pieces, *K*, *P*, are borne up to catch in a similar way, by blade-springs underneath, each portion of the hooks being loosely jointed to the disc links, *L*, *Q*.

The whole of the movements are driven by the first motion shaft, *W*, in connection with the steam-engine. The spur wheel, *X*, on this shaft, gears with a wheel, *Y*, fast on a short carrier shaft, having upon it a pinion, *Z*, in gear with a large spur wheel, *A*. The wheel, *A*, is fast on

a longer shaft, *B*, carrying as well three wheels of regularly graduated diameters, gearing with three inverse corresponding wheels on the shaft, *C*. These wheels are capable of being engaged in any given pairs, like the speed cones of a lathe, so that the shaft, *C*, can be driven at three different rates, with a continuously regular motion of the driving shaft. As represented in the plate the slowest motion is in gear, the least wheel of the driving series, on the shaft, *B*, being in gear with the largest one on the opposite shaft, *C*. This latter shaft also carries a spur pinion, *D*, driving the large wheel, *E*, on the right and left screw spindle; and its prolonged end also carries a bevil pinion, *F*, in gear with the bevil wheel, *F*, fast on the spindle of the capstan or windlass barrel, *G*, for a simple hauling motion. This driving gearing, which, of course, may be variously arranged to suit actual localities, is also furnished with reversing gear, such as an open and crossed belt movement, for the purpose of driving the screw in alternate directions. The action of the purchase is this:—The ship being upon the carriage, one of the drag hooks of the traversing nuts is passed upon one of the angular shoulders of the traction chain, just as both hooks are represented in our drawing. The gearing is then put in motion to drive the screw, and the obvious result of the screw's rotation is, that one of the nuts, *F*, *G*, is made to traverse along its guides, *H*, towards the central junction of the right and left threads, whilst the other traverses in the opposite direction, so as to approach one end of the spindle. In the position here selected for illustration, the two nuts are shown at the extreme ends of the spindle, the nut, *G*, having traversed to the landward extremity of the screw, whilst the nut, *F*, has similarly reached the other, or seaward end. The screw's movement is therefore to be reversed at this stage, causing the two nuts to approach each other, the hook, *O*, becoming the hauler, whilst the other one, *J*, slides freely back over the smooth edge of the chain. The traverse of each nut is made to correspond exactly with the length of the individual chain links, so that, as the screw is continuously driven in alternate directions, each hook alternately catches and slips in its operation upon the chain, and the carriage with the ship upon it, is thus steadily and continuously drawn up the incline.

The hauling chain is always preserved in its complete unbroken condition, and, as a convenient means of stowing the hauled up length, it is wound upon the hexagonal drum, *U*. Each of the sides of this drum corresponds exactly with the length of the chain links, so that in winding up, the bend can always take place with facility, from the joints hitting the angles as they come round. The pair of inclined standards, *H*, carry this drum, by means of the horizontal screw shaft, *I*, the ends of which, *J*, are squared to fit immovably in square recesses on the tops of the standards. The boss of the drum is formed as a nut to fit the screwed shaft, the pitch of the threads of which is made to agree with the space required for the chain coils. In this way, when the hauling commences, the drum is always stationed near one end of its spindle, and as the loose end of the chain comes forward, it passes upon the drum, causing the latter to turn as each link is laid on. This revolution of the drum then causes its lateral traverse along the screw, so that the chain coils are thus wound up spirally, without interfering with each other. As the carriage is lowered to the water, the reverse movement takes place, and the chain winds off, each link being supported in turn as it goes down, by the traction hooks alternately, just as in the upward traverse.

Our drawings are made from a purchase constructed by Messrs. Lyon, Lawson, & Co., of Camlachie, Glasgow, for an Australian slip. To that firm considerable credit is due, for the general working out of the designs, and the arrangement of the mechanical details. The purchase is decidedly the best which has been hitherto devised, whether as regards, the beautifully steady and uniform action of the right and left screw movement, or the elegant means of coiling up the hauling chain in one unbroken length.

MECHANIC'S LIBRARY.

Ancient Art, Illustrations of, 4to., 25s., cloth. Rev. E. Trollope.
Curvilinear Perspective of Nature, 12s. 6d. W. G. Herdman.

RECENT PATENTS.

EVAPORATING AND CONCENTRATING APPARATUS.

G. I. HIGGINSON, *Meeting-house Lane, Dublin*.—Patent dated May 25, 1853.

This very elegant contrivance consists of a hollow rotating screw, working in the liquid to be evaporated, and having steam passed through the continuous flattened chamber formed by the spiral threads, so as to furnish an extended heating surface for lifting up thin films of the evaporating matter. Our engraving represents the evaporator in longitudi-

CONTINUOUS-ACTION SCREW PURCHASE FOR SLI

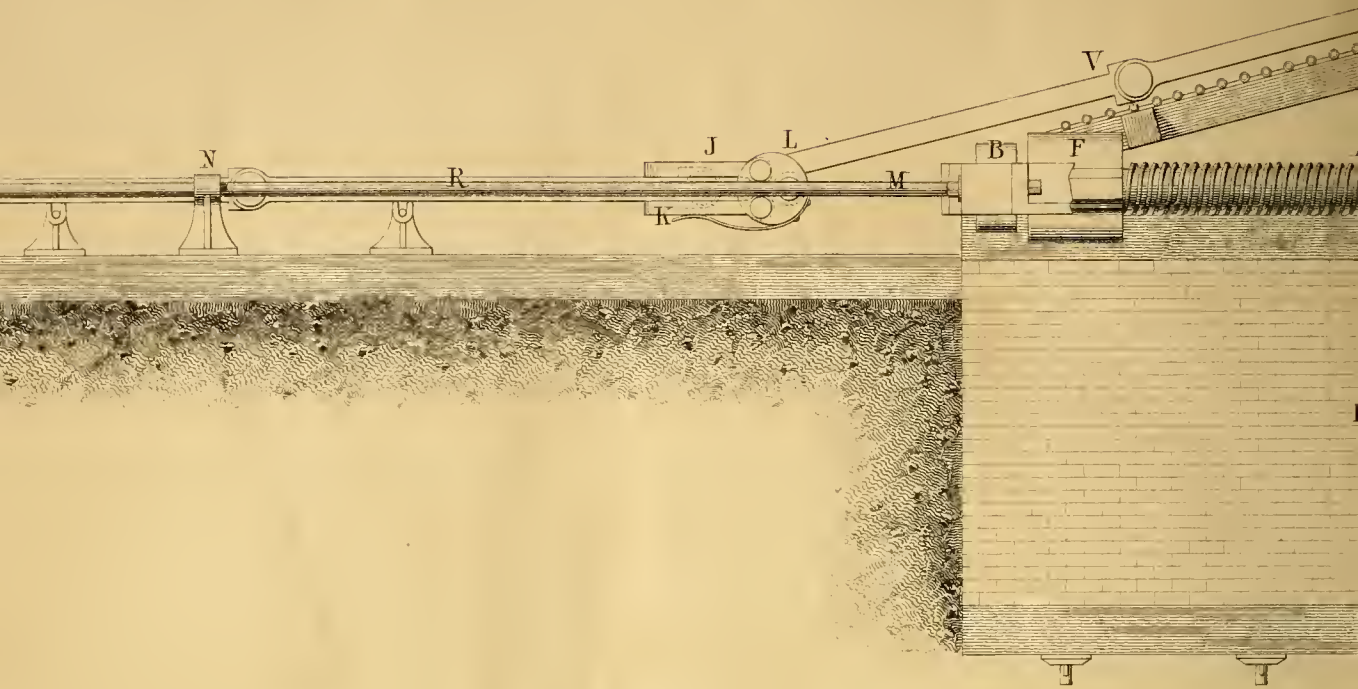

J. SCOTT, SHIPWRIGHT, FALKIRK.

Fig. 2

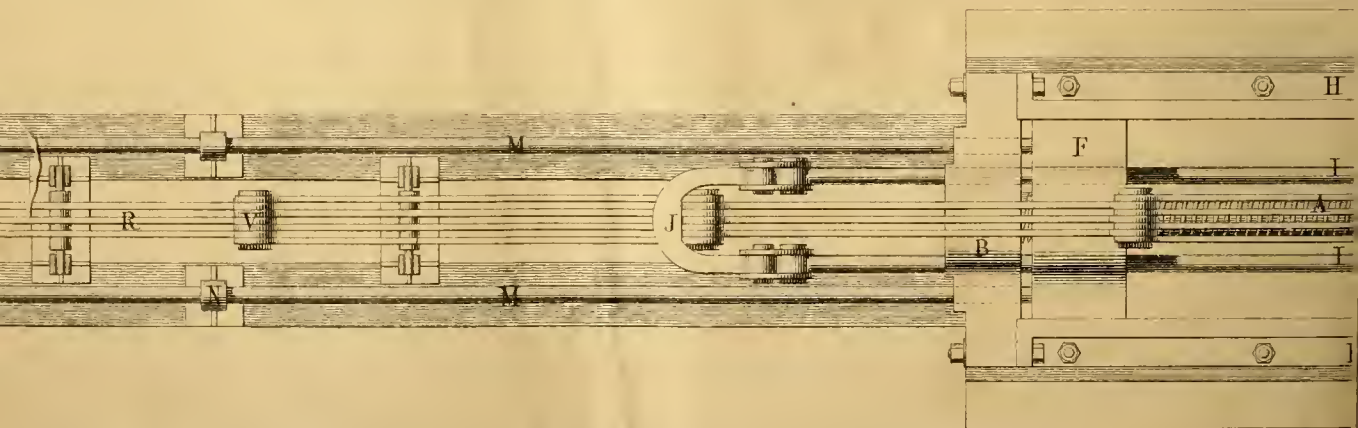

SCALE

INS 0 5 10 15 20

Fig. 1.

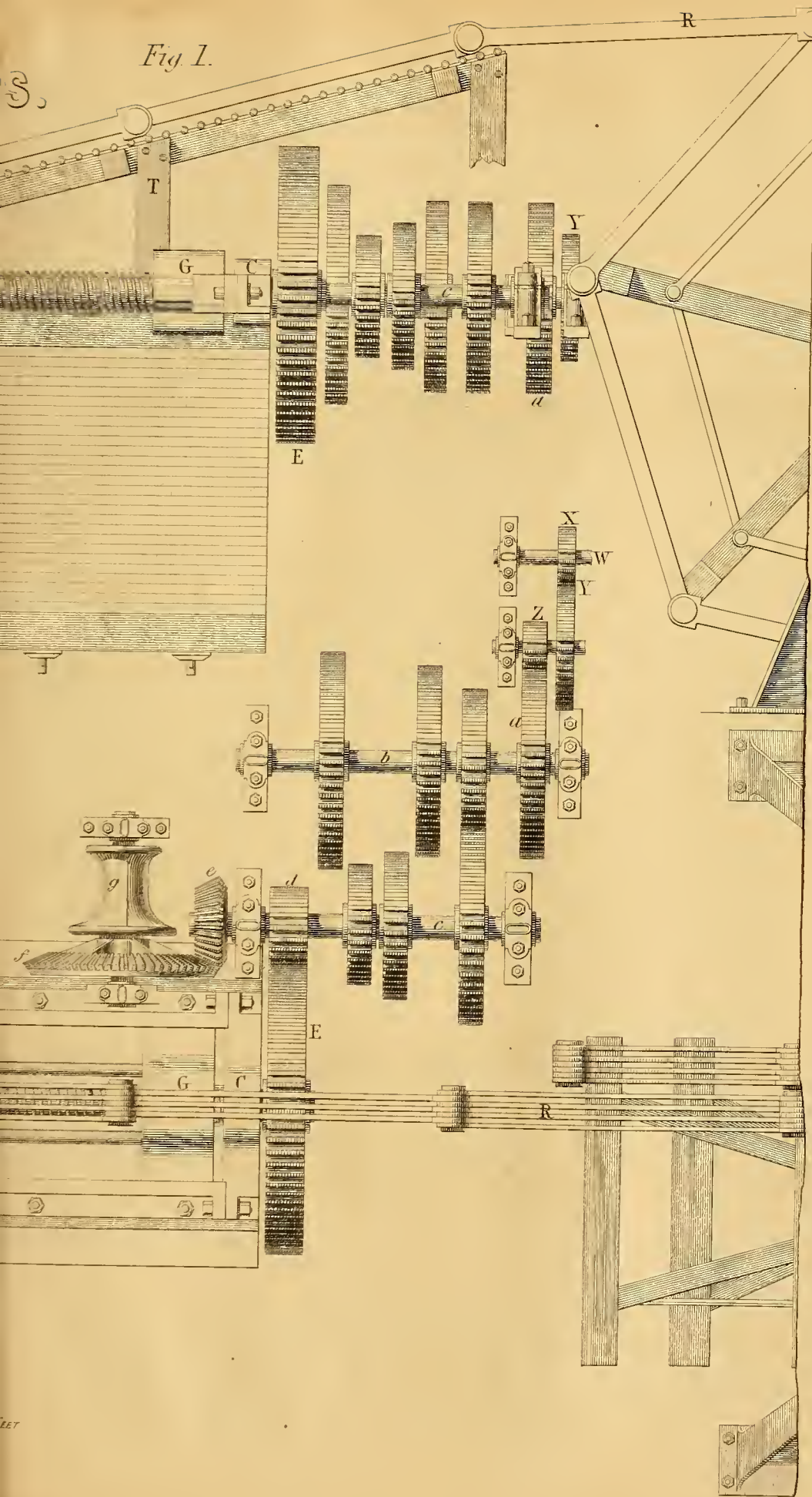

CONTINUOUS-ACTION SCREW PURCHASE FOR SLIPPS.

Fig. 1.

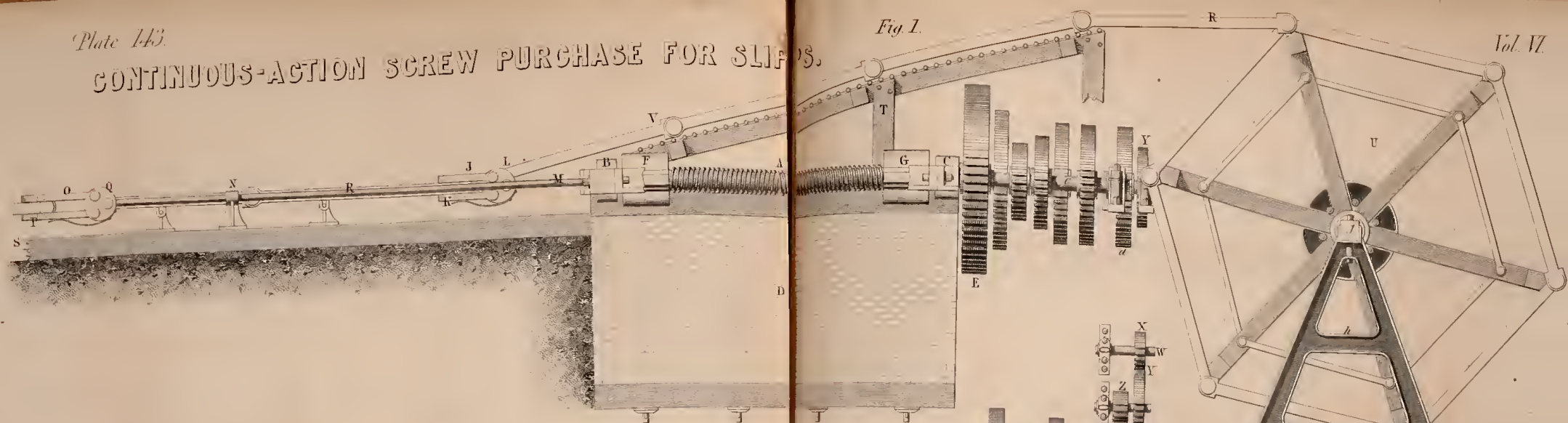

J. SCOTT, SHIPWRIGHT, FALKIRK.

Fig. 2.

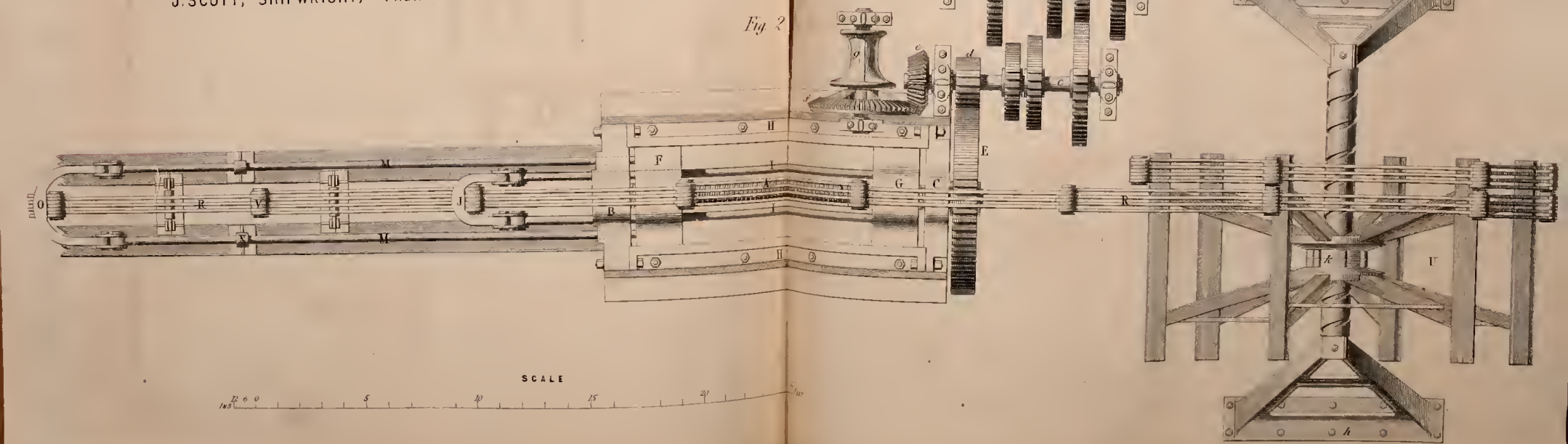

SCALE



dinal section, as used for the concentration of syrup in the sugar manufacture. In this figure, *A* is the evaporating chamber containing the liquid to be evaporated. It is open on its upper side, and is surrounded externally, on all its other sides, by a steam space, *B*, formed by the external jacket or casing, *C*. On the upper edge, at each end of this chamber, is a bearing, *D E*, forming the end carrying supports for the main tubular shaft, *F G*, which is made to rotate at the desired rate by means of a spur-wheel, *H*, keyed on one end of the shaft, and in gear

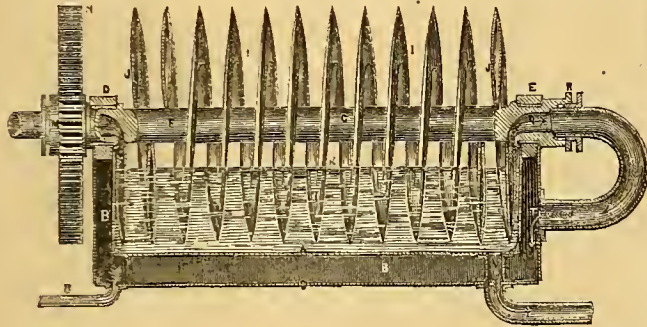

with any convenient prime mover. It is on this main shaft that the hollow screw blade, or spiral disc thread, *I*, is wound. This screw thread, which is of narrow, double-convex, transverse section externally, as represented at *J*, may be conveniently made of dished or hollowed metal plates, built and soldered, or otherwise attached together. It forms a continuous steam thoroughfare from end to end, contrived so as to present a broad thin stratum of steam to the evaporating liquid, the level of which, in the containing chamber, is represented at *K*. The heating steam for the entire apparatus passes from the boiler through the fixed pipe, *L*, at one end of the shaft, the open inner end of which pipe is connected with the shaft by the stuffing-box, *M*, so that the shaft has liberty to revolve quite independently of the pipe, *L*. The open end of the pipe, *L*, is in a direct line with the tubular end, *N*, of the main shaft, so that the steam, in passing from the pipe, *F*, can flow through the stuffing-box, *M*, without escaping as the shaft revolves. The tubular portion, *N*, of the shaft, thus supplied with steam, has a lateral opening, *O*, communicating freely with the end of the spiral screw, through the hollow, *J*, of which the steam can thus flow uninterruptedly along the whole of the convolutions. After thus traversing along all the turus of the screw, the steam similarly escapes through a lateral opening, *P*, at the opposite end of the shaft, into the hollow, *Q*, at that end of the shaft. At this point, a second stuffing-box, *R*, serves to form a steam-tight communication between the hollow in the revolving main shaft and a stationary curved pipe, the other end of which pipe is bent back, and opens into the steam case, *B*, of the containing vessel, *A*, at the point, *T*. In this way the steam, after exercising its evaporative effects upon the spiral blades or screw, *I*, is employed in keeping the containing vessel well heated. Whatever water of condensation may be formed in the steam space, *B*, is allowed to flow off by a small pipe, *U*, and at the opposite end of the apparatus is a large pipe, *V*, opening into the containing chamber, for the periodical discharge of the boiled matter.

In working this apparatus, the constant revolution of the screw both exposes a large heating surface to the evaporating mass, and, at the same time, traverses and agitates that mass in the vessel by the screw action. Hollow discs, or surfaces of other forms, may likewise be used instead of screw blades for a similar purpose; and, instead of causing the heated surfaces to revolve continuously, a reciprocatory rotation may be employed; whilst, for some purposes, the steam may be cutted the reverse way, first passing through the outer casing of the containing vessel, and afterwards through the screw blades.

MOULDING IN METAL.

JULIAN BERNARD, *London*.—*Patent dated April 25, 1853.*

The versatile inventive talents of Mr. Bernard have been devoted, in this instance, to the development of a highly elegant mode of casting in metal, or moulding in plastic substances, whereby a peculiarly effective sharpness in the reproduction of form is secured. The entire novelty lies in the fact of the extraction of the atmosphere from the moulds or matrices, in which the shaping takes place. When metal is operated upon in this way, the pot, ladle, or crucible, concerned in the process,

may have a plugged hole in the bottom, the vessel being placed over a channel in communication with the mould; and the mould may be kept at any desired temperature by steam or heated air.

Fig. 1 is a vertical section of the arrangement, as applied in casting a steam-engine cylinder. The mould boxes, *A, B*, are joined together by the flanges, *C*, one of the sections having its bottom cast on it, whilst the other one is fitted with additional flanges, *D*, to receive the cover-plate, *E*. Both sections may have

Fig. 1.

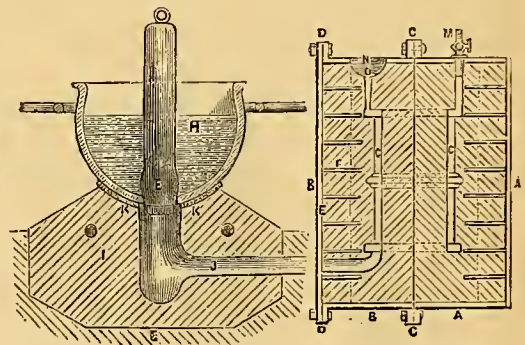

supporting bars, *F*. The mould is prepared in the usual way, the sectional surfaces being so placed together as to be air-tight, the object being to exclude the atmosphere from the moulding space, *G*.

The ladle, *N*, is supported on the fire-brick mass, *I*, composed of two pieces, the division being along the channel, *J*. A bed of loam, *K*, is laid in the seat of the ladle, to exclude the air, and a fire-clay plug, *L*, into the bottom aperture of the crucible, being kept in its place by the superincumbent pressure of the fluid metal.

At *M* is a stop-cock, temporarily fitted into the top of the moulding boxes, and a flexible tube is led from this cock to an air-pump, and the air is in this way exhausted from the moulding space. When a sufficient vacuum has been made by pumping, the cock, *M*, is closed, and the plug, *L*, in the ladle, is withdrawn; so that the atmospheric pressure forces the metal down from the ladle into the mould, from the bottom, until the level of the cup, *X*, at the top, is reached. The opening in the bottom of this cup is closed before the exhaustion takes place, by a lower disc, *O*, fitted loosely on; but when the metal reaches this point, the disc is displaced, and the presence of the melted metal in the cup, *X*, indicates that a sufficient quantity has been poured in. The plug, *L*, of the ladle is then let down, to stop any farther supply; and thus none can enter the cock, *M*. When the casting operation is completed, the ladle is removed, and the brick base, *I*, is divided longitudinally, so that the solidified metal within it is easily extracted.

Fig. 2 is a vertical section of a mould, similarly contrived, for shaping plastic substances. The mould, *A*, is in two halves, joined by central flanges, *B*, to form an air-tight joint. In the instance before us, a flower vase is being cast, the internal core, *C*, forming the capacity of the vase, being held in position by the slightly overlapping conical piece, *D*, at its upper end. An exhausting cock is fitted to the mould at *E*, and an inlet, *F*, is made at the bottom, for the admission of the plastic matter. When exhaustion takes place through the cock, *E*, the bottom stop-cock, *G*, is closed; and when the vacuum has been formed, the cocks are reversed. The plastic material is thus forced into the mould by atmospheric pressure, aided or not by separate mechanical force.

Fig. 2.

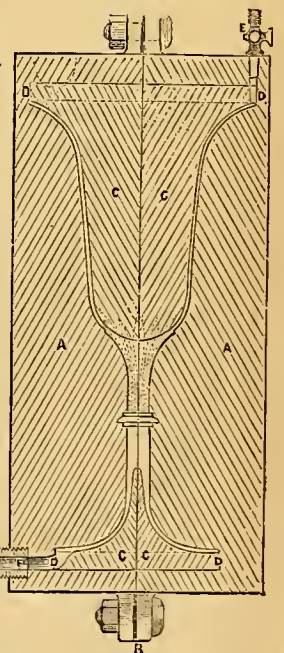

In addition to his treatment of metals by this process, Mr. Bernard proposes to mould gutta percha, caoutchouc, earthenware, and other plastic or soluble matters, in a similar way, thus giving the accuracy and sharpness so much desired in all objects where external configuration is the essential feature in the design.

TIMBER SHIP-BUILDING.

SAMUEL SCHOLLICK, *Ulverston*.—*Patent dated May 20, 1853.*

Mr. Schollick's invention, which essentially relates to the construction of the frames of timber-built ships, is a clever contrivance for combining pieces of timber in such a manner as to secure great strength in the curved framing pieces.

Fig. 1, A¹ and B¹, represents the timbers as primarily cut for bending. Fig. 2, A² and B², is a view of the timbers bent on the wooden plat-

Fig. 1.

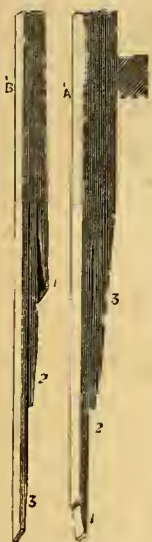

Fig. 2.



form, and screwed and wedged tightly together to the intended curvature, after being steamed. Fig. 3, A³ and B³, shows the curved frames set up for planking.

In commencing to build a ship on this principle, the timbers are all sawn out, in the first instance, to the form, A¹ B¹, in fig. 1, and in this state they are put up to season.

Fig. 3.

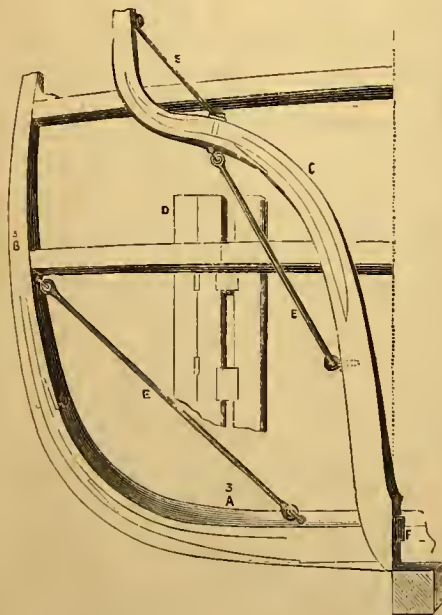

When ready for putting the ship together, the pieces are steamed and bent on a platform and allowed to cool down in that position. Tarred felt is then inserted between the saw-gates, and the iron rods, shown at E, in fig. 3, are put on, to keep them to the required shape until the ribs are put on, and the framing is ready for planking. The rods can then be cut up for bolts, and the cyes are found useful in various parts of the ship.

The part, C, is a piece of stern framing, as set up after this plan of treatment; and at D is a piece of framing,

keyed together sideways, to prevent their lifting. This shows waterways behind. At F is a tenon in foot of stern framing, to fasten into dead-wood. The timber, A, is continued and scarfed on the other side of the ship, like that between A³ and B³. Inside planking may be put on temporarily at first, and then the outside, bolting the two firmly to-

gether. Framing so made is nearly as strong as that made of solid timbers; and hence it has received the name of "whole framing."

CONICAL FIRE-BOX BOILER.

JOHN CAMERON, *Manchester*.—*Patent dated Nov. 3, 1852.*

This is a vertical boiler, with a cylindrical shell, hemispherical on its top. Fig. 1 is a vertical section, and fig. 2 a sectional plan of the boiler. The fire-box is formed of two cones—a large external cone, A, with an inverted cone, B, within it. These two cones converge to a junction at their upper ends, the connection between them being by an annular piece of semi-circular section. There are two fire doors, C, set one-third of the shell's circumference apart; and the whole stands upon an open cast-iron base, D, through which the central water-space cone, B, descends. The smoke passages, E, are made near the top of the external cone, the gaseous current being made to pass off, along curved external channels, to the chimney at F. Under this form, the boiler is, of course, an independent metal structure; but, by encasing the external shell with brickwork, leaving an annular space between the brickwork and the shell, the heated air may pass along this space to the chimney, and so make the external surface available for heating.

Fig. 1.

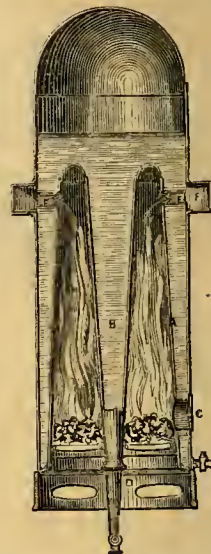

Such a boiler possesses many advantages. It is economical in space, it is easily made, and it is of the strongest form consistent with economy. The inclined cone surfaces are also favourable to the due application of the heat; and a very thin stratum of water is opposed to the heating surfaces, whilst the water line presents the whole area of the boiler. In the event of the water running low, the strongest and least heated part of the fire-box is first laid bare, and any deposit from the water is productive of far less injury than in common boilers. There are also several favourable points in it as regards marine purposes.

Amongst other examples of working boilers on this construction, one, which has been twelve months in use, blew off steam from its safety valve, loaded to 25 lbs., in twenty minutes after lighting the fire.

Fig. 2.

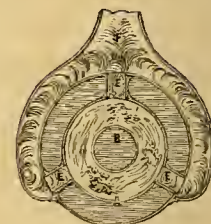

CHIMNEY-TOPS AND FLUES.

ROBERT LISTER, *Scotswood Tile Works, Newcastle*.
Patent dated June 17, 1853.

This is a very simple contrivance for aiding chimney draughts and ventilation, and preventing "down draughts," the only addition to the common flue or chimney-top being a few small tubes. These tubes may be placed either inside or out. In our illustrative figure they are disposed outside, in a spiral form, the top or shell itself consisting of a square base, A, immediately above which is a torus, or annular and rounded moulding, B, joined, by a small fillet, C, to the main cylindrical or slightly tapered body, D, of the chimney-top. It is around this last-mentioned portion of the chimney-top that the draught-tubes, E, are disposed. Their lower ends are immediately above the narrow fillet, C; these ends are open to the external air, and may be formed in any manner that may be deemed best for receiving or catching any

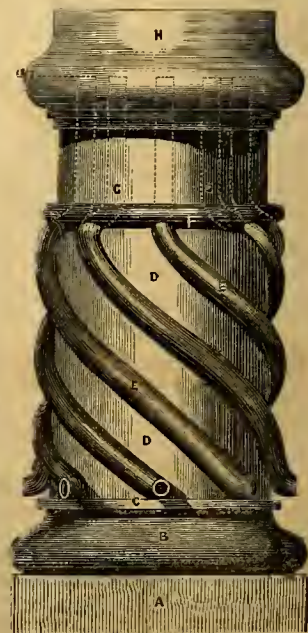

current of air. Thus, they may be formed with openings of the same diameter as the body of the tube, or they may be formed with trumpet-shaped mouths, so as to catch external air currents, and direct them up the bodies of the conducting tubes. These tubes, *e*, are made cylindrical throughout, from mouth to mouth, and they may either be made of clay, or other plastic material, or of metal. In the example before us, their lower receiving mouths are turned with a slight curve outwards, and from this point each tube winds spirally round the chimney shell or top, and then passes into the interior of the top, through a suitable aperture in the thickness of the shell, at a point just beneath the head or annular moulding, *f*. After passing through the shell's thickness, each tube bends sharply upwards, as at *g*. The whole of the tubes are arranged in a precisely similar manner, and after this internal return bend, each passes up to the level of the line, *ab*, so as to form a ring of tubes rather less in diameter than the internal diameter of the chimney-top, and stopping somewhat short of the top of the ornamental capital, *h*, of the chimney-top.

Mr. Lister shows several other forms of chimney-tops, with the additional draught-tubes variously arranged. In one of these modifications, the tubes run parallel with the axis of the main shell; in another, instead of a series of tubes, an internal cylinder is fitted to the main shell, leaving an annular space between the two. A ring of lateral openings is made in the main shell, just above the bottom moulding, to form a communication between the external atmosphere and the annular space, and the internal shell is carried up to the same height as the separate tubes in our engraving.

With chimney-tops arranged according to this general principle, all side currents will be directed, more or less, up some of the external tubes, or along the internal annular passage, so as, on escaping near the head of the capital, the ascending air stratum inside the top will act upon the passing smoke and gases, and greatly improve the chimney draught. At the same time, if a "blow-down" is threatened, these tubes or passages will afford material aid in preventing the down flow of the smoke, by carrying off the deranging air current clear of the chimney current.

MARINE CHRONOMETERS.

GEORGE PHILCOX, London.—Patent dated Nov. 13, 1853.

Fig. 1.

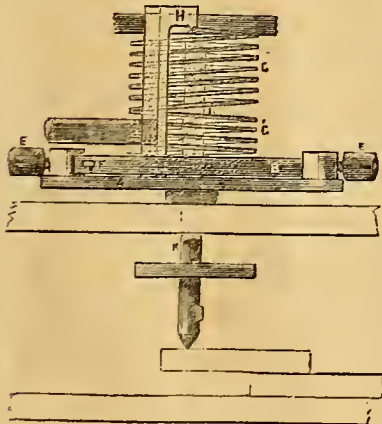
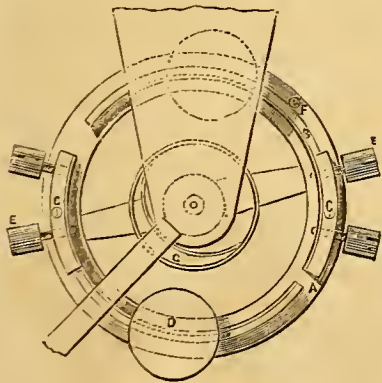

Fig. 2.

Fig. 1 is a plan, and fig. 2 is a side elevation, of Mr. Philcox's new compensating balance. *A* is the plain steel or brass balance, with compensating arms, *B*, composed of brass and steel in the usual way, the attachment to the balance being by one or two screws, *C*. One of the balance weights is at *D*, the other, being under the bracket, and at *E*, are the regulating screws. An eccentric screw, *F*, is introduced, to adjust the compensating arms, *B*, in extremely cold temperatures. The chief improvement in this balance consists in the employment of two volute springs, *G*, *G'*, which act in reverse directions, by which means all variation in the action of the springs, due to change of temperature, is compensated for. In figs. 3 and 4, respectively a plan and elevation, another arrangement is shown, in which the reverse springs are on opposite sides of the balance-wheel. The same literal references

and description apply to figures 3 and 4 as to figures 1 and 2; κ is the spindle of the balance-wheel and π is the bracket, to which the outer ends of the springs are attached. Mr. Philcox's improved escapement is represented in three different positions in figs.

Fig. 3.

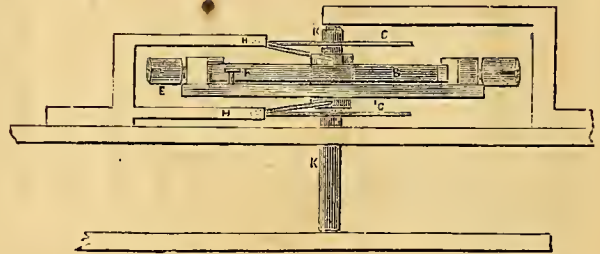
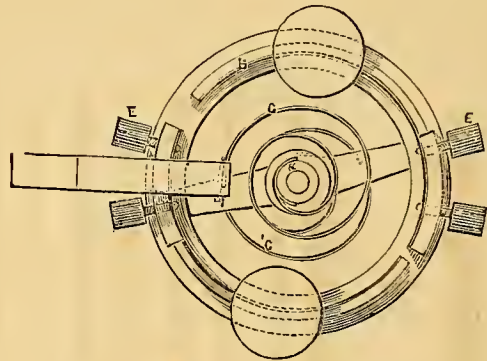

Fig. 4.

5, 6, and 7. *c* is a notched disc upon the spindle of the propelling lever, and is acted upon by the escape disc, *D*, whilst a second disc, *F*, below, acts upon a projection on the spindle of the disc, *c*. In this arrangement a great deal of rubbing surface is got rid of, and the friction is consequently reduced. This escapement is used in combination with a train, by means of which half-seconds are obtained by a fifth wheel. Where a fifth wheel is not employed, the escapement disc, *D*, must have nine acting points cut upon it, instead of four. Mr. Philcox, however, recommends the introduction of a fifth wheel, stating, that he thereby obtains a much better action.

Fig. 5.

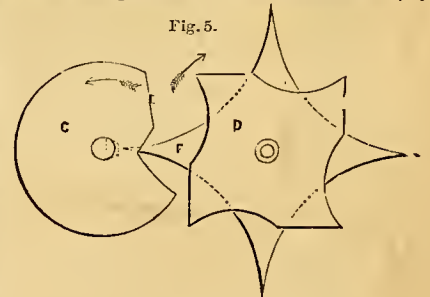

Fig. 6.

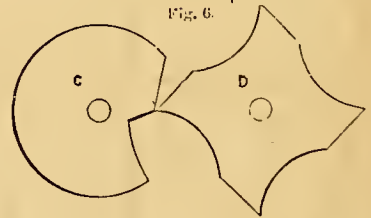
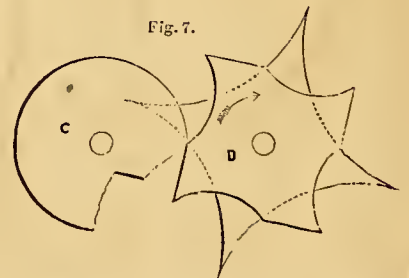

Fig. 7.



A plan is also shown of jewelling the staff of the impulse lever with a solid ruby, instead of the hollow one now used, and also a form of pendulum rod, in which pieces of steel and brass are combined, in a peculiar manner, so as to compensate for any variation of length produced by alteration of temperature. All these arrangements are characterized by great ingenuity and elegance of design.

UNIVERSAL RATCHET DRILL.

F. A. CALVERT, *Manchester.*

Fig. 1.

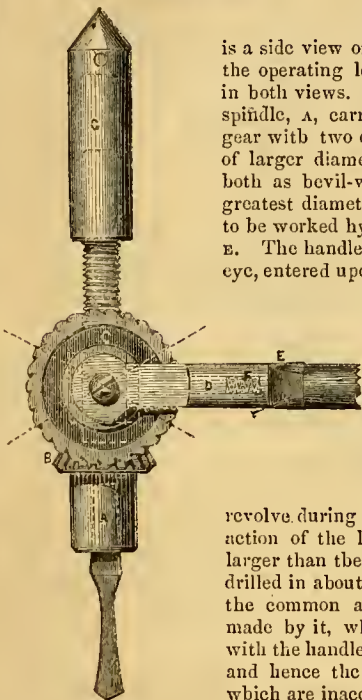
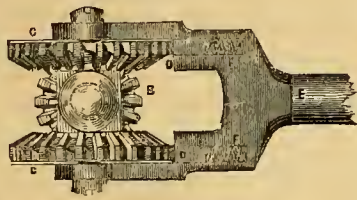

Fig. 2.

The "universal ratchet-drill" is now being introduced by Messrs. F. Lewis & Sons, the well-known tool-makers, of the Stanley Street Works, Manchester.

MOULDING IN METAL.

J. W. HOBY, & J. KINNEBURN, *Renfrew.*—*Patent dated Nov. 26, 1853.*

This contrivance relates to the use of fire-clay as a material for iron-founders' moulds. Either fire-clay alone, or fire-clay mixed with clean course sand, or grit and plumbago, is used as the raw material of the moulds. These moulds are baked at a red heat, like common fire-bricks, and they are either solid or in pieces carefully joined—the moulding faces being smoothed either before burning, or by frictional action afterwards with a final wash of plumbago. If in pieces, the junction edges are treated with plastic clay to secure them, and a plumbago wash is given after each casting. Any slight injury sustained by the mould during working may be repaired with common loam; and, in this way, the inventors propose to employ the same mould for many successive castings. Our illustration represents a portion of a pipe mould of this kind, in longitudinal section. The fire-clay mould, A, is divided longitudinally into two semi-cylindrical portions. The core, B, is made on a core-bar, C, in the ordinary manner. The lower end of the core is fitted into the bottom of the mould, which is slightly contracted in diameter. The mould rests upon a plate, D, within a ring, E. Another plate, F, is placed on the top of the fire-clay mould, and connected to the bottom-plate, D, by three bolts. The "gate-box," G, is filled with sand, in which gates or passages are made for the introduction of the liquid metal in the ordinary manner. A ring, H, is supported by the pins,

I, and this serves to maintain the upper end of the core in its proper position. The gate-box fits on to three pins, J, in the top-plate. The two portions of the mould are held together by hoops of iron placed round them. The mould so bound together may be placed in a pit, and sand rammed around it. The inside of the mould is warmed by a current of hot air, or in any other convenient manner, and it is brushed with a wash of plumbago, applied by means of a long-handled brush. The ore is then introduced and the gate-box put in its place, and the fluid metal is then poured in. When it has become solid, the core-bar is lifted out of the mould and the pipe adheres to it, and separates from the mould by its own contraction. In lieu of making the mould in two or more pieces, it may be made in one piece, where the casting is of such a form as to be capable of being removed from it. The fire-clay is improved by the admixture of about one-fifth of its weight of sand or old fire-brick ground to powder. Moulds for pipes and other circular castings may be made by means of a "sweep," or board, turning upon centres in the ordinary manner of preparing loam moulds. The sweep may be edged with iron, in order to produce a smoother surface on the clay, as it is found advantageous to make the surface as smooth as conveniently may be before burning the mould in the kiln. When the mould is of considerable height, it is built up at intervals, so as to allow the clay in the lower part to settle, as is practised in making pots or crucibles for melting glass. The mould is burned or baked at a red heat, so as to destroy the plasticity of the clay, and convert it into brick. The wash of plumbago, used for coating the surface is made by mixing powdered plumbago with water, or with beer or yeast. The ordinary blacking, made with charcoal, and employed for coating the surfaces of moulds of other descriptions, may be employed in lieu of the plumbago wash.

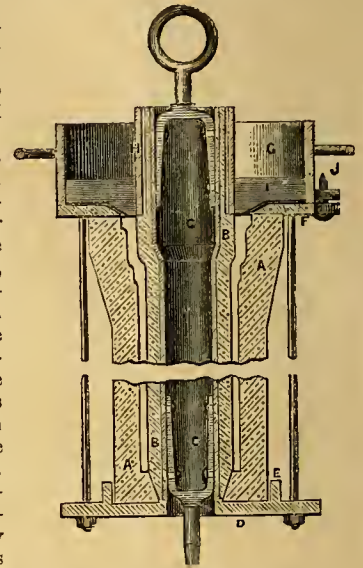

REVIEWS OF NEW BOOKS.

AN ATTEMPT TO DEFINE THE PRINCIPLES WHICH SHOULD DETERMINE FORM, IN THE DECORATIVE ARTS. By M. Digby Wyatt, Esq. Bogue, London, 1853.

A very slight reflection indeed upon the present state of civilization is sufficient to impress us with the truth of the proposition, that a time has now arrived in the world's history, when generalizations of a higher order than we have been accustomed to ought to be made. The conception of a proposition of this kind is evidence in itself of the momentous period at which we have arrived; for it is not confined to the painstaking philosopher, shut up in his study, in complete seclusion from the world, or roaming at large, in his wider spot of investigation, the broad expanse of nature and art. Every thinking man in these times—be he high or low, learned or unlearned, according to the schools—has made this discovery for himself; and wherever the proposition is stated *viva voce*, it seems to mount up at once, as it were, upon a hundred wings, and fly abroad, as a scroll, legible by all. Some great things are at hand. Some intelligence has begun amongst us its embryonic existence, and we may hope, at least the younger of us, to live to see the embryo take the form and substance of the time. Human activities, of all orders, are crowding around us, compelling into their labouring fellowship the most dread and mighty processes of nature. The observer is about. He has hunted up, among the secret passes and concealed glens of the earth, a great many wonders and excellencies, each of which bears a glass, which distinctly reflects to our vision many more. But, above all, a mightier conqueror has yet to come—a mightier conquest has yet to be made. Is the Baconian mode of investigation an ultimate fact, beyond which nothing is to be eliminated? or is it but a glimpse, a stepping-stone to some other safe and true conclusion, which shall eclipse it, as much as it eclipsed all moulded thoughts of other minds? But we must not in this place, and now, anticipate what we may have

further to say, by and by, on such things. Let it suffice that the present publication has drawn us out a little more than our own volition alone would have done; for it is from reflection upon such things that we have ourselves ventured to stray into regions of thought, heterodox, it may be, as this world is wagging, but, as we believe, orthodox as regards the Great Truth which envelops all things.

Our best thanks are due to Mr. Wyatt for thus "coming out." It is not every one, if he think such thoughts, that would publish them, and in print too. It is not every one who is so bold. But it is not for this only that our best thanks are due to Mr. Wyatt. We have a *Great Teacher* here. His teachings are the natural result of a long discipline in the supreme of arts—architecture—combining the beautiful and the useful, wherever it has appeared;—and where has it not? The difficulty is to review a work of this character, in which almost every sentence might form a text, upon which many long pages could well be written, and which suggest matters of the deepest importance to society at large. Willingly would we transfer the whole of the contents to our columns; for we ourselves are teachers, and our effort is to teach what we learn. But our limited space compels us to refer only, when we would extract; and we assure our readers, at all interested in the subject—our young readers especially—that they will do well to invest one of the smallest coins of the realm in the purchase, and to employ a few hours in a thorough study of the pages here offered to their notice.

The principles here attempted to be defined, as the results of careful analysis of both the works of nature and the works of man, are, variety, fitness, simplicity, contrast, and truth. On each portion of his subject, the able essayist has many profound and just observations; and in treating of their application to decorative art, there is very much that is new, told in a style as simple and unpretending as the matter is interesting and important. The following passages will, we hope, induce many of our readers to recur to the original pages in which they are to be found. Truth in art is the writer's immediate idea:—

"When we turn to a consideration of the united action upon human design of the general principles of consistency exhibited in the works of nature, we find that, of all qualities which can be expressed by the objects upon which our executive ability may be occupied, the noblest and most universally to be aimed at, is plain and manly Truth. Let it ever be borne in mind, that design is but a variety of speech or writing. By means of design, we inscribe, or ought to inscribe, upon every object of which we determine the form, all essential particulars concerning its material, its method of construction, and its uses. By varying ornaments, and by peculiar styles of conventional treatment we know that we shall excite certain trains of thought, and certain associations of idea. The highest property of design is, that it speaks the universal language of nature, which all can read. If, therefore, men be found to systematically deceive—by too direct imitation of nature, pretending to be nature—by using any material in the peculiar style of conventionality universally recognised as incident to another—by borrowing ornaments expressive of lofty associations, and applying them to mean objects—by hiding the structural purpose of the article, and sanctioning, by a borrowed form, the presumption that it may have been made for a totally different object, or in a perfectly different way,—such men cannot clear themselves from the charge of degrading art by systematic misrepresentation, as they would lower human nature by writing or speaking a falsehood. Unfortunately, temptations to such perversions of truth surround the growing designer. The debilitating effects of nearly a century's incessant copying without discrimination, appropriating without compunction, and falsifying without blushing, still hind our powers in a vicious circle, from which we have hardly yet strength to burst the spell. Some extraordinary stimulant could alone awaken all our energies; and that stimulant came—it may not, perhaps, be impious to esteem providentially—in the form of the great and glorious Exhibition. It was but natural that we should be startled when we found that, in consistency of design, in industrial art, those we had been too apt to regard as almost savages, were infinitely our superiors. Men's minds are now earnestly directed to the subject of restoring to symmetry all that had fallen into disorder. The conventionalities of form peculiar to every class of objects, to every kind of material, to every process of manufacture, are now beginning to be ardently studied; and instead of the vague system of instruction by which pupils were taught, that anything that was pretty in one shape was equally pretty in another, a more correct recognition of the claims of the various branches of special design, and the necessity of a far closer identification of the artist with the manufacturer, in point of technical knowledge, have been gradually stealing upwards in public estimation. Let us hope that success will crown exertion, and that in time the system of design, universally adopted in this country, will offer a happy coincidence with those lofty principles, by means of which the seals of truth and beauty are stamped on every emanation from the creative skill of Divinity."

The following on styles, as the Grecian, the Roman, the Gothic, the Renaissance, &c., is as profound as it is probably true. A very little reflection upon it must produce a long commentary in every mind capable of duly appreciating such teaching:—

"Styles may be regarded as storehouses of experiments tried, and results ascertained, concerning various methods of conventionalizing, from whence the designer of the present day may learn the general expression to be obtained, by modifying his imitations of nature, on the basis of recorded experience, instead of his own wayward impulses alone. Canova, Gibson, and many of the greatest masters in art, held, and hold, the creed, that nature, as developed in the human form, can only be rightly appreciated by constant recurrence to, and comparison with, the conventionalities of the ancient sculpture of Greece. Mr. Penrose has shown us what beautiful illustrations of optical corrections in line may be gathered from the study of her architectural remains. Mr. Dyce, who has made himself deeply acquainted with the ancient styles, thus expresses himself upon the subject:—'In the first place,' he remarks, 'the beauties of form, or of colour, abstracted from nature by the ornamentist, from the very circumstance that they are abstractions, assume, in relation to the whole progress of the art, the character of principles, or facts, that tend, by accumulation, to bring it to perfection. The accumulated labours of each successive race of ornamentists are so many discoveries made—so many facts to be learned, treasured up, applied to a new use, submitted to the process of artistic generalization, or added to—a language and a literature of ornamental design are constituted; the former of which must be mastered before the latter can be understood, and the latter known before we are in a condition to add to its treasures. The first step, therefore, in

the education of ornamentists, must be their initiation into the current and conventional language of their art, and, by this means, into its existing literature."

HOME RESORTS FOR INVALIDS—ON THE CLIMATE OF GUERNSEY. By S. E. Hoskins, M.D., F.R.S. Pp. 20. 8vo. London: 1852.

This is a reprint from the "London Journal of Medicine" of an article contributed to the "British Meteorological Society." The observations which it furnishes were made in consequence of frequent applications which reached the author, with the view of obtaining information as to the sanative influence of Guernsey as a place of residence. Going seriously to work, on a meteorological examination, he arranged his apparatus thus:—

"The barometer employed until the end of June, 1851, was one of Newman's, with an iron cistern and brass scale, made for the Observatory at St. Helena, and compared with the standard at the Royal Society. Unfortunately, the minutes have been lost, so that the correction for index error is wanting, as well as that for elevation above the mean level of the sea, amounting to 123 feet. Corrections for capacity, capillarity, temperature, and diurnal range, have, however, been carefully applied. The instrument now in use was made by Barrow, and compared with the standard at Greenwich by Mr. Glaisher. The tube requires no capacity correction; those for capillarity and index error amount to +.027. It is placed in a dressing-room, in which the temperature is equal, and its readings are registered at 9 A.M. and 3 P.M. daily.

"The thermometers consist of registering instruments, for maximum and minimum temperature, on Rutherford's construction; they are read at 9 A.M. daily, when the indices are re-adjusted; these, as well as a delicate wet and dry bulb thermometer, are made by Newman. They are grouped together about four feet from the floor of a shed, built for the purpose in a small garden, which receives no ray of sunshine from November to March. Nevertheless, a white double camella japonica blossoms freely in this plot of ground during the months of January and February. The aspect of the instrument is north by east; the nearest object is a dark blue granite wall, thirty feet distant, and ten feet high; a higher wall forms the western boundary; and a house front, with an intervening street, the eastern side of the otherwise open space they occupy. They are completely protected from radiation and reflection by an open trellis, and some shrubs, before and on each side of the pent-house. Until the end of 1848, the dew point was observed by means of Daniell's hygrometer, made by Newman; since that time it has been computed from the readings of Mason's wet and dry bulb hygrometer, at 9 A.M. and 3 P.M., by the means of Mr. Glaisher's tables.

"The rain-gauge is a copper funnel, twelve inches in area, forty-seven above the ground, which discharges its contents into a closed reservoir, from which the water is measured at 9 A.M., by means of a graduated glass jar. The receiving funnel is remote from walls, chimneys, or other influence.

"The direction of the wind is chiefly ascertained by a very delicate vane, constructed according to Mr. Luke Howard's plan. In estimating its force, a calm is represented as 0, a gale as 6."

His deductions, apparently made with every care, are that "persons from the northern and midland counties of England, with temporarily impaired health, but without any specific disease, derive the greatest benefit from removal to this island;" and he commends it "as a transition stage, between the East and West Indies and England, for individuals whose health has suffered from long residence in tropical climates." A comparative table of actual meteorological results, and a list of plants which bloom in Guernsey, in the open air, during the winter months, are valuable appendices to the pamphlet.

NOTES ON THE ORGANIZATION OF AN INDUSTRIAL COLLEGE FOR ARTIZANS.

By T. Twining, jun. Pp. 32.

LETTERS ON THE CONDITION OF THE WORKING CLASSES OF NASSAU. Same Author. Pp. 55. London: Barclay. 1854.

The introductory letter, heading the first of these pamphlets, found a place in this *Journal* as far back as Part XLII., Vol. IV.; and at that time the benevolent author expressed his intention of going further into the matter during a visit to he made to Germany and France. Accordingly, the pages now presented to us have sprung into being from considerations due to a three months' continental visit, during which the successful *Geuerbe Institut* of Berlin, the *Conservatoire des Arts et M^{ét}iers*, and the Industrial Schools at Chalons, Angers, and Aix, all contributed to the author's information on the subject in hand. The result is, that he has drawn up a "Review of matters to be considered in reference to the proposed College of Trades," with the especial view of eliciting extraneous opinions on the matter. This suggestive statement relates chiefly "to the organization of the Central Industrial College, which, we assume, might, allowing free scope for progressive enlargements, be made to accommodate at the first about 300 students, representing, in duly apportioned numbers, a considerable variety of trades—artistical, chemical, and mechanical. They would enter as good workmen, being required to give previous proof of such abilities as can be derived from an ordinary apprenticeship; they would be instructed, collectively, in general information, and, by groups, in special knowledge; they would be trained to work with head as well as hand, and to appreciate and apply the advantages of science and the graces of art, and they would leave the college fully qualified to become, some masters in trade, others foremen or first-rate workmen; whilst others, again, carefully selected and instructed for the purpose, would become teachers in their turn, and diffuse throughout the country the advantages of industrial education."

The actual propositions contained in this *Review* are, in many points, carefully considered, and on that account highly valuable; and we con-

ceive that their wide dissemination would be productive of a great good, in setting thinking minds to work in aid of the general project.

The author's Nassau letters, which are addressed to the Council of the Society of Arts, embody a "Report on the intellectual and technical training, earnings, household economy, and institutions," established for the benefit of the industrial population of Nassau; and they are thrown out in the hope of being "but No. 1 of a long string of miniature likenesses, each representing the industrial features of some foreign country, and each somewhat rounded in itself, yet only acquiring its full value by the concatenation and joint meaning of the whole."

The five chapters on "Primary education, technical training, earnings, expenses, and resources," into which Mr. Twining's gleanings are divided, are in the highest degree creditable to the writer's head and heart. With him, we hope that his collected information will indeed be the precursor of many other such contributions, which will reflect back to us the true state of our industrial position here, by showing us how contemporary affairs stand abroad.

HINTS TO INTENDED GOLD-DIGGERS AND BUYERS—AUSTRALIA THE ANCIENT OPIUM. By G. F. Goble. London: Effingham Wilson. Pp. 64. 1853.

"Having fitted out some hundreds of gold-diggers," the author very naturally thinks he knows something worth communicating to those who are dreaming of wild adventure in the gold countries; and he has here strung together some pithy hints, purchased by his own actual experience abroad. The chapters on "Bush Chemicals" and "Tools," suitable for the diggings, are especially worthy of consultation by those for whom the gold countries possess attractive charms. The title of the second division of the pamphlet affords its own explanation.

CORRESPONDENCE.

STUFFING-BOX GLAND ADJUSTMENT.

The annexed sketches represent a simple contrivance for operating upon two or more gland nuts of a stuffing-box at one time, so as to give a quicker and more accurate adjusting power than is available at present.

Fig. 1 is a half sectional elevation of the new form of stuffing-box, and fig. 2 is a plan. A circular rack or wheel, A, is made to gear into the pinion nuts, n, c, D, which answer as gland nuts; the main pinion, D, being arranged for the application of an actuating key or spanner, in the usual way. By turning this main nut, it moves the circular rack, and the latter then actuates the rest of the nuts, thus causing them all to move at once, and to one level. In putting this contrivance together, the nuts are all screwed down to one starting level—say, to the amount of their own depth—by the finger and thumb. The circular rack is then dropped down into gear, upon the collars of the nuts, and the set are finally worked down upon the gland face. This clearly obviates the danger of canting the gland, and producing undue friction on the working-rod.

I would suggest that in cases where three bolts are used, the screw-threads should be of fine pitch, say, half the usual pitch, so that the whole three might be worked with little more power than is required for a single bolt under ordinary circumstances. A worm might be made to work into the circular rack, A, but this is not necessary, and would involve additional complication.

Such an arrangement as I have here proposed, might be advantageously applied to the glands of trunk engines, where many bolts are required; or in pump glands of large diameter, as well as in large piston-rod glands. The latter application, especially refers to oscillating marine engines, which make long voyages without once stopping; as the packing may thus be operated upon

whilst the cylinders are in action. Or if the vibration of the cylinders is too rapid, the engines might be eased a few strokes, to allow of tightening up without stoppage. Care must, of course, be taken to place the main nut in the most convenient place as relates to the cylinder—and where there is the least vibration—that is, in a line with the trunnions.

ELIAS BARLOW.

Hull, January, 1854.

SNOW SLEDGE FOR CARRIAGES—DEEP SEA SOUNDING—SAFETY MINING GEAR.

The present season has powerfully reminded us of the great difficulties arising from deep falls of snow, as regards the use of wheeled carriages.

At the time I write, three horses are necessary for doing the work of one, under ordinary circumstances. It appears to me that a species of

Fig. 1.

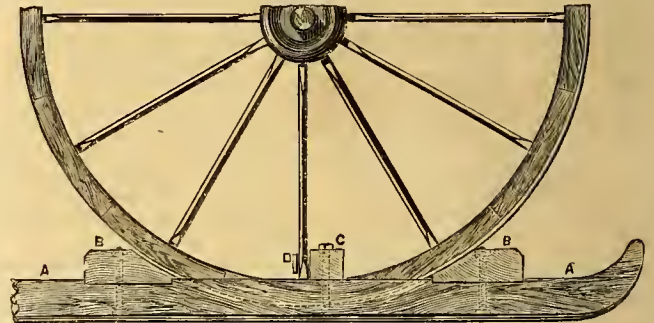

sledge, which could be applied to carriages and carts without involving the removal of the wheels, would be very useful under such circumstances. In case of sudden thaw, the apparatus could be easily removed.

Fig. 2.



Fig. 1 represents such a contrivance drawn to 1-12th the real size. It is composed of four stout pieces of timber, and the wheel is intended to drop between the two longer pieces, A, resting upon the fore and aft cross pieces, n. The loose piece, c, is intended to keep the wheels secure in their place, by being screwed down after the carriage has been set upon its sledge carrier. The two irons, D, are intended to grasp the spokes. These are better shown in the side view of the cross piece, fig. 2.

I observe, from your December Journal, that Lieut. Maury proposes to carry out his "deep sea sounding" plans, by releasing a heavy shot from an iron rod attached to the sounding line, upon the apparatus reaching the bottom of the sea. Now this may be effectually done by the simple insertion of a pine or other soft wood lath, just below the shot, in a slot made through the rod. The feeble wood will, of course, break on reaching the bottom, and thus release the shot. I should myself use a piece of fire brick, or thick tile made for the purpose, as being cheaper than cast-iron. Fig. 3 is a sketch of my plan. A is the metal rod on the end of the sounding line, B the weight, and c the transverse piece of lath.

Fig. 3.

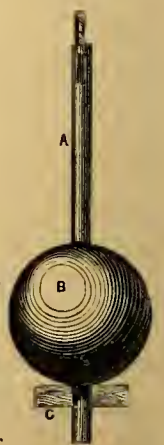

I am glad to find that my safety mining gear, which you illustrated in December last, has come under the immediate notice of Lord Palmerston, who has communicated it to the different mining inspectors of Government.

C. BUTLER CLOUGH.

Tyddyn, Mold, January, 1854.

FISH JOINTS FOR T RAILS.

I beg to submit to your notice a proposal for a fish joint for T rails, of which fig. 1 is a section near or at the joint, fig. 2 a side view, and fig. 3 a plan. By means of this plan, the joint is easily and firmly secured without the use of screws or rivets, and the fishing piece may be also as easily and speedily disconnected when required. To gain these advantages, it is necessary that the rail should be of the section shown in fig.

1, which differs from those in common use in the hollow of one side of the rail between the top and the base, being formed with straight lines,

Fig. 1.



Fig. 2.



instead of a curved one, and the base on this side being partly inclined and partly horizontal.

As soon as the rail is rolled and sawn to the required length, it being yet hot, each of the ends on the side with straight lines is put successively under a press, and the edges turned up perpendicularly to the base of the rail, say three inches lengthwise, at one end. The edges are not turned up exactly parallel to the rail, but are slightly inclined to it, say an eighth of an inch to each three inches, thus making an inclination of a quarter of an inch for both of the

Fig. 3.



turned-up edges, the breadth turned up at the ends of the rail being equal, so that when two rails are laid end to end, the degree of inclination through the turned-up edges is the same, forming a wedge-shaped space between the edges and the side of the rail.

The rails being laid, a fishing piece with a wedge-shaped flange, shown in section at fig. 1, is to be driven into the space between the turned-up edges and inclined base and the under side of the upper part of the rail. The side of the wedge-shaped flange is inclined in the same degree as the turned-up edges. The fishing-piece itself is made a little broader than the space between the flat under side of the upper part of the rail and the inclined base at the narrowest part, so that as soon as the small end of the fishing piece has been driven as far as the further end of the narrowest turned-up edge, it cannot go further forward, except by forcing itself laterally between the flat underside of the top part of the rail and its inclined base. The flange of the fishing piece being acted on by the inclined turned-up edges, is the cause of the lateral movement. Thus a firm and unyielding joint is produced, without any more trouble than is required to drive a key.

It can be shown how provision, if required, may be made for expansion and contraction at every third or fourth joint, by two slight additions to the fishing-piece and rail.

January, 1854.

KENNETH.

ELECTRO-MAGNETIC MOTIVE POWER.

Would you, or any of your readers, be kind enough to afford me some information in answer to the following queries:—

1. What is the principal obstacle which has hitherto prevented the production of an effective, and at the same time economical, electro-magnetic engine.
2. Which, and what, is the peculiar construction of the most successful engine of the kind.
3. Is a current of electricity, passing through an engine, diminished or absorbed, in proportion to the amount of work given out.
4. Which is the best recently-published work on the subject.

MAGNET.

Glasgow, January, 1854.

WRIGHT AND HYATT'S ELLIPTIC ROTATORY ENGINE.

In the *Practical Mechanic's Journal* for December, 1852, where this engine is described, it is stated that a certain property, there pointed out, "is a peculiar and unlooked-for characteristic of the elliptical figure." This sentence is calculated to give rise to the impression that the ellipse, as a mathematical curve, possesses some property hitherto undiscovered. It struck me in this light at the time, but I felt inclined to consider, judging from the context, that such was not the real meaning intended to be conveyed, it being subsequently stated, that "the true action can only be attained in a figure of very small eccentricity;" and it is obvious, that if the ellipse possessed the property alluded to, the amount of eccentricity would be of no importance, theoretically speaking.

Now the ellipse, whatever may be its eccentricity, does not possess the property alluded to, in a strict mathematical sense; although, in a figure of small eccentricity, a point may be found so situated, that the chords drawn through it will not vary very considerably in length, and

No. 71.—Vol. VI.

the approximation may be sufficiently good to admit of practical application in the manner described, as, indeed, is proved by the result of Messrs. Wright & Hyatt's experiment.

Let any doubt should remain in the minds of your readers with regard to the theoretical accuracy of the principle involved, I subjoin a process, which proves that the ellipse, as a mathematical curve, does not possess any such property, and affords a simple expression by which the actual length of any chord may be calculated, and the actual amount of the difference easily ascertained.

Assuming the well-known equation of the ellipse with reference to the centre as origin, and the arcs as co-ordinates—viz.,

$$y = \frac{b}{a} \sqrt{a^2 - x^2},$$

we find at once the situation of the point, O; in which it is required that O A shall be equal to b , by making $x = b$ in that expression—which gives us, for the corresponding value of y or C O, the expression—

$$\frac{b}{a} \sqrt{a^2 - b^2}.$$

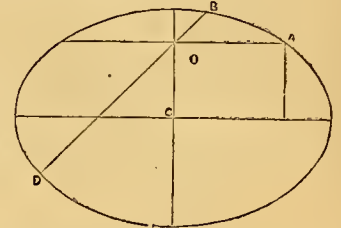

From this it follows, that the algebraical equation of the ellipse, with reference to the point, O, as origin, and the co-ordinates, O A and O C, is

$$y + \frac{b}{a} \sqrt{a^2 - b^2} = \frac{b}{a} \sqrt{a^2 - x^2},$$

or $ay + b \sqrt{a^2 - b^2} = b \sqrt{a^2 - x^2};$

from whence we obtain, by squaring both sides of the equation—

$$a^2 y^2 + 2ab \sqrt{a^2 - b^2} \cdot y + b^2 (a^2 - b^2) = b^2 (a^2 - x^2),$$

or $a^2 y^2 + b^2 x^2 + 2ab \sqrt{a^2 - b^2} \cdot y - b^4 = 0.$

If, in this last expression, we now substitute for x and y , their values, $V \cdot \cos. \theta$, and $V \cdot \sin. \theta$; V being the radius vector, and θ the theoretical angle, made by the radius vector, with the base, O A, at the origin, O, we have the following expression:—

$$(a^2 \sin^2 \theta + b^2 \cdot \cos.^2 \theta) V^2 + 2ab \sqrt{a^2 - b^2} \cdot \sin. \theta \cdot V - b^4 = 0.$$

From whence is at once deduced the polar equation of the curve, with reference to the origin, O, and base, O A; namely,

$$V = \frac{\sqrt{4 a^2 b^2 (a^2 - b^2) \sin^2 \theta + 4 b^4 (a^2 \sin^2 \theta + b^2 \cos.^2 \theta)} - 2ab \sqrt{a^2 - b^2} \sin. \theta}{2(a^2 \sin^2 \theta + b^2 \cos.^2 \theta)} = \frac{b \sqrt{a^2 \cdot \sin.^2 \theta + b^4 \cdot \cos.^2 \theta} - ab \sqrt{a^2 - b^2} \cdot \sin. \theta}{a^2 \sin^2 \theta + b^2 \cos.^2 \theta}.$$

If now, we have any chord, B D, passing through the point, O, and let V' represent O B, the value of O D, which, we may call V' , will be obtained by substituting $\pi + \theta$, for θ , in the above expression; and we shall therefore have—

$$V' = \frac{b \sqrt{a^2 \sin.^2 \theta + b^4 \cdot \cos.^2 \theta} + ab \sqrt{a^2 - b^2} \cdot \sin. \theta}{a^2 \sin^2 \theta + b^2 \cdot \cos.^2 \theta};$$

since

$$\sin. (\pi + \theta) = - \sin. \theta, \text{ and } \cos. (\pi + \theta) = - \cos. \theta.$$

And the value of the chord, B D, which is equal to the sum of B O and O D, will be represented by

$$V + V' = 2b \cdot \frac{\sqrt{a^2 \cdot \sin.^2 \theta + b^4 \cdot \cos.^2 \theta}}{a^2 \sin^2 \theta + b^2 \cdot \cos.^2 \theta}$$

This expression assumes the value, $2b$ —, when $\theta = 0$, and when $\theta = \frac{\pi}{2}$, but under no other circumstances, whatever may be the relation of a and b ;

and it proves, therefore, that the ellipse does not possess the property alluded to, of having a point, O, in the minor axis, so situated that all chords passing through it are of equal length; while, at the same time, as it gives an expression for the value of such chord, in terms of the semi-major and semi-minor axis, a and b , and of the angle, θ , it affords an easy mode of calculating the actual length of such chord in any given ellipse, for any given value of the angle, θ .

It would be an interesting exercise for any of your readers, who may be so inclined, to investigate the nature of the relation existing between the maximum length of such chord, and the eccentricity of the ellipse. But as such investigations can hardly be interesting to the majority of your readers, I need not pursue the subject farther.

Halshead, Essex, Nov., 1853.

WILLIAM DAVISON.

[It is quite true that, in a strict mathematical sense, the property alluded to does not belong to the ellipse, a fact well known to the invent-

tors of the elliptic rotatory engine; but the approximation is so close, as to render the principle true in practice. Taking a piston, measuring 18 inches, and making it turn on a centre, 6 inches from the end of the conjugate axis of the elliptic cylinder, it will only require to vary in length about its $\frac{1}{20}$ th part, or the $\frac{1}{12}$ th of an inch. Now, the spring packing which would be necessary, even were the principle mathematically true, provides quite sufficiently for this trifling variation. Added to this, there will be a constant tendency to wear truer, as the greater pressure of the spring packing will be upon those parts of the cylinder where the shorter chords occur. But Messrs. Wright and Hyatt's engine does not depend entirely on the adoption of the elliptic figure for its novelty and superiority. This figure has been previously proposed by many parties. Not so the beautiful and practical arrangement of the piston and the piston-shaft, which admit of the employment of packing of so simple and efficient a description. These arrangements are claimed, under the patent, in combination not only with an elliptic chamber, but also with a chamber of any differentially or otherwise curved form answering the purpose.—Ed. P. M. JOURNAL.]

PROCEEDINGS OF SCIENTIFIC SOCIETIES.

INSTITUTION OF CIVIL ENGINEERS.

DECEMBER 20, 1853.

J. M. RENDELL, PRESIDENT, IN THE CHAIR.

ANNUAL GENERAL MEETING.

The annual report of the council touched, amongst other matters, upon the scarcity of papers furnished to the meetings by the members. It is to be hoped that the actual statement of facts on this subject will induce the members to add somewhat to the present meagre supply of matter.

The principal papers read, during the past session, were enumerated, with a short notice of each, and of the tenor of the discussions, which were shown to be the distinguishing features of the meetings of the society. It was apparent, that those were the most valuable papers which were the most readily furnished by engineers, as being observations of the effects of natural causes, in constant operation, in the vicinity of work constructing under their direction, and the attention of members was urged to that point.

The following medals and premiums were presented:—Telford Medals to Messrs. Coode, Clark, Brooks, Huntington, Burt, Duncan, Siemens, Cheverton, and Barrett; and Council Premiums of Books, to Messrs. Richardson, Armstrong, Rawlinson, and Sewell.

Attention was directed to the engraving of Mr. Andrews' portrait of the past-president, Sir John Rennie; to the portrait of Brindley, presented to Mr. Hawkshaw; and to a marble bust of the first president, Telford, by Hollins, which had been lost sight of for many years, and only accidentally recovered by the secretary within the last few months. It was now restored to the institution, for which it had been originally destined, and Mr. Rendell, as a last act of presidentship, presented for it a pedestal appropriately carved from a block of Peterhead granite—a material which had been so extensively employed in the works of the first president of the institution.

The vital importance of printing the arrears of the minutes of proceedings, and of giving rapid publicity to the papers and the abstracts of the discussions, was generally admitted; the question had occupied the serious attention of the council, and nothing but the fear of involving the institution in hopeless financial difficulties had caused the present arrears of publication. After giving an account of the progress of the printing of the volumes of the transactions and of the minutes of the proceedings, showing the gradual extension and the cost, it was demonstrated, that there existed no other bar to the rapidity of publication, than the extent to which the members of all classes were willing to assess themselves, by voluntary or compulsory contributions, to defray the inevitable amount of expenditure for printing.

This statement produced a lengthened discussion, which resulted in the determination, that contributions should be collected from members of all classes on the following scale:—President, thirty guineas; past-presidents, vice-presidents, and members and associates of the council, twenty guineas each; members, five guineas each; and associates, one guinea each. This assessment was cheerfully agreed to, and several members and associates present doubled the amounts of their contribution, to aid in the very desirable object of the immediate publication of the minutes of proceedings.

The following gentlemen were elected to fill the several offices in the Council for the ensuing year:—James Simpson, President; G. P. Bidder, J. K. Brunel, J. Locke, M.P., R. Stephenson, M.P., Vice-Presidents; J. Cubitt, J. E. Errington, J. Fowler, C. H. Gregory, J. Hawkshaw, T. Hawksley, J. R. McLean, C. May, J. Penn, and J. S. Russell, Members; and H. A. Hunt and C. Geach, M.P., Associates of Council.

JANUARY 10, 1854.

J. SIMPSON, PRESIDENT, IN THE CHAIR.

The newly chosen president delivered his customary address; after which the discussion on Mr. Harrison's paper was resumed.

JANUARY 17.

Renewed discussion on Mr. Harrison's paper.

SOCIETY OF ARTS.

NOVEMBER 30, 1853.

W. BIRD, ESQ., IN THE CHAIR.

"On the Consumption of Smoke," by Mr. A. Fraser.—The author commenced by remarking, that it was not intended to enter upon the various theories which had been advanced upon the subject, or to discuss the many inventions before the public, still less to bring forward any new theory, but to give the "results of absolute work," in a successful attempt to remove the smoke nuisance from an extensive London brewery and its neighbourhood. Messrs. Truman, Hanbury, Buxton, and Co., had tried most of the plans, which, previous to 1847, gave reasonable hopes of success. It was unnecessary to allude to these, but a general remark might be made respecting many of them, viz., that any plan requiring additional attention on the part of the stoker—such as the opening or closing of air-valves—or giving him extra labour, which was required in some cases, was found in practice to be unsuccessful, although a single experiment, carefully conducted, might seem to prove the contrary. In 1847, the writer's attention was first drawn to Jucke's Patent Furnace, which consisted of a strong cast-iron frame of the full width of the furnace, and about three feet longer. The fire-bars were all connected together, forming, when complete, an endless chain, and were made to revolve round a drum, placed at each end of the frame. The front of the frame was provided with a hopper, in which the fuel was placed, and a furnace-door, which opened vertically with a worm and pinion. The height to which this door was raised by the stoker regulated the supply of coal, which was carried into the fire by the gradual motion of the bars. This plan was first applied to an engine-boiler—a cylindrical one, with two tubes—driving a 40 horse-power engine. Having been successful, it was adapted to a second boiler of the same kind. In the same year, the probability of its success under a brewing copper was discussed. There was no doubt, from the former experiments, as to its capabilities for raising steam or for evaporation; but with a brewing copper, provision had to be made for a process in the manufacture almost peculiar to it. The contents of the copper have to be turned out several times in the course of a brewing, rendering it necessary to "bank up" the fire thoroughly, to protect the bottom of the copper, until refilled with wort or water. It was feared that the machinery would interfere with this being done effectually; it was tried, and with the same success as with the steam boilers. The remainder of the coppers and boilers were afterwards altered. The total cost of the fourteen furnaces, including brick-work, had been about £3,000. The consumption of coals in the establishment was about 6,000 tons per annum. The saving in the coal account, since the introduction of the patent, to July 1 of the present year, had been £8,338; from which must be deducted for casualties and sundries, say £350. The above economy had not arisen from less weight of fuel consumed, but owing to the screenings or dust of coal only being required for the furnaces. Should the difference of price between large and small coals be reduced, the economy will be less in future years. It would appear, at first sight, that the wear and tear of a machine, apparently so complicated, must exceed the expense of the common fixed bars. This, however, has not been found to be the case, and it need not be so, if ordinary care be given to the machine, and a periodical examination, such as any other machine of equal value, and producing equally important results, would receive. Within the last week, a set of bars had been renewed, for the first time, which had been in use since May, 1849; and three-fourths of the old bars were being again used for another furnace, where the boiler was of less importance than the one from which they have been removed.

DECEMBER 7.

HARRY CHESTER, ESQ., IN THE CHAIR.

Before the reading of the paper, the secretary called the attention of the meeting to a large number of specimens which had been received from the Imperial Printing-office at Vienna, produced by the process known in Germany as "Naturselfdruck," and in this country as "Phytoglyphy," or the art of printing from nature. These specimens included every variety, botanical, geological, entomological, fossil, and fabrics. In the year 1851, Dr. Ferguson Branson communicated to the society "an account of a method of engraving plates from natural objects," which was read at a meeting held on the 26th March in that year, and was published in the notices of proceedings at the time. Dr. Branson only contemplated the application of the process to ferns, leaves, seaweeds, and other flat plants. The method he adopted was to impress the object itself into gutta percha, or other soft material, and then to obtain an electrotype from the mould. The novelty in the present process consisted in the use of lead for receiving the impression, in place of gutta percha; and also for applying to the polished surfaces of minerals a weak acid, which acted with different degrees of intensity on the materials of which the mineral was composed, and so caused a greater or less indentation. The moulds from the fossils were taken by liquid gutta percha. Specimens were also exhibited by Messrs. Bradbury and Evans, who are working the process in this country.

Samples were exhibited from Dr. Forbes Royle of cultivated "Rhea Fibre," from Assam, produced by Boehmeria Nivea, which was the plant which yields the Chinese grass, of which the fine grass cloth is made; also the wild Rhea fibre.

The Anglo-Franco-Algerian Vegetable Fibre Company also exhibited some samples of "Jute, Palm, and Ditz Fibres," in various stages of manufacture, prepared by Claussen's process.

DECEMBER 19.

W. BIRD IN THE CHAIR.

Discussion, "On the Consumption of Smoke."

SCIENTIFIC DEPARTMENT OF THE BOARD OF TRADE.
MUSEUM OF PRACTICAL GEOLOGY.

The following courses of lectures have commenced at the Metropolitan School of Science applied to Mining and the Arts:—

Thirty lectures "On Applied Mechanics," by Professor Willis, F.R.S., commenced January 4, at twelve o'clock.

Thirty-six lectures "On Geology," by Professor Ramsay, F.R.S., commenced January 5, at one o'clock.

Fifty lectures "On Metallurgy," by Dr. Percy, F.R.S., commenced January 6, at eleven o'clock.

Twenty-four lectures "On Paleontology," by Professor E. Forbes, F.R.S., commenced January 6, at one o'clock.

Fifty lectures "On Mining," by W. W. Smyth, M.A., commenced January 9, at three o'clock.

The Chemical and Metallurgical Laboratories re-opened for the winter session on the 4th January.

Officers of the Army and Navy, in the Queen's or the H.E.I. Company's Service, acting mining agents or managers, members of the College of Preceptors, and certificated schoolmasters, can attend the lectures at half the usual charges.

ROYAL SCOTTISH SOCIETY OF ARTS.
ANNUAL GENERAL MEETING.
NOVEMBER, 1853.

DISTRIBUTION OF PRIZES.

1. William Alfred Roberts, M.D., Duke Street, Edinburgh, for his "Description of an Apparatus for Cauterizing the Dental Nerve by means of Galvanism."

The Society's Silver Medal and Plate, value Ten Sovereigns.

2. Mr. John Kolbe Milne, Hanover Street, Edinburgh, for his "Description of a New Gas-Stove for economically heating Ornamental Tools, and Glue for Dressing-Case Makers."

The Society's Silver Medal, value Five Sovereigns.

3. William Hushand, M.D., Clarence Street, Edinburgh, for his paper "On the Adaptation to every-day practice of the Capillary Tube Method of preserving Vaccine Lymph."

The Society's Silver Medal.

SPECIAL THANKS.

1. George Wilson, M.D., Edinburgh, for his "Communication on the Prevalence of Colour-Blindness or Chromato-Pseudopsis, and the limit which it puts to the use of Coloured Signals on Railways, at Sea, and elsewhere."—With a grant of Ten Pounds, to assist in defraying the expense of the prosecution of his important researches.

2. Robert Ritchie, C.E., Hill Street, Edinburgh, for his elaborate communication "On Mechanical and other contrivances for Ventilation, with a description of a New Method for Ventilating Buildings by means of Steam Apparatus," with a model.

3. Robert Henry Bow, C.E., Edinburgh, for his "Description of New Designs for Iron Roofs of great clear span," &c.; with drawings.

The committees on Mr. Stewart Hepburn's Suggestions for the prevention of Railway Accidents arising from Collision, and on Mr. Campbell's Communication on the Cause of the Antilunar Tide, and his Review of the Theories held by different Philosophers on that subject, have not yet given in their reports.

No communication was read during the past session to which it seemed proper to award the Keith Prize of Thirty Sovereigns.

DECEMBER 12.

"On Decimal Notation and Currency," by J. Alexander.

DECEMBER 19.

PROFESSOR KELLAND IN THE CHAIR.

"On the Time-Ball recently erected on Nelson's Monument, in connection with the Royal Scottish Observatory, Edinburgh," by Professor C. P. Smith.

MARLBOROUGH HOUSE.

DEPARTMENT OF SCIENCE AND ART.

Eight lectures "On the Human Form" are now in course of delivery by John Marshall, Esq., Assistant Surgeon to University College Hospital, as under:—

I.—3d January—The Human Form considered as an object of Art.

II.—10th January—The Hard or Angular Elements of the Human Form. The Bones with the Joints.

III.—17th January—The Soft or Round Elements of the Human Form. The Muscles, Skin, and Interposed Structures.

IV.—24th January—The Forms of the Torso.

V.—31st January—The Forms of the Limbs.

VI.—7th February—The Forms of the Head and Neck.

VII.—14th February—The Varieties of the Human Form, dependent on Sex, Age, Character, Nation, and Race.

VIII.—21st February—The Human Form, as influenced by the Will, the Passions, Disease, Sleep, and Death.

LIVERPOOL POLYTECHNIC SOCIETY.

DECEMBER 5.

H. P. HORNER IN THE CHAIR.

Mr. Maxwell Scott read a paper on his new Screw Propeller, and exhibited several models illustrative of its practical construction.

We gave particulars of this invention last month, in our notes on the "Progress of Screw Propulsion."

MONTHLY NOTES.

LONDON GAS.—We have ever zealously advocated the universal introduction of gas lighting. We wish to see it adopted as fully in our dwellings, as it has already been in our manufactories and shops. This economical and cleanly light, in our opinion, ought to be used in the drawing-room, bed-room, library, and boudoir. Look at the example which Scotland has set in this respect. There every town, even of the smallest, has its well-accustomed gas-works. A candle, or an oil lamp, is rarely seen, and with them a vast aggregate of dirt and disagreeables of various kinds has been effectually abolished. In many parts of England, and particularly in London, the rule is the very reverse. Something of this is owing to baseless prejudice—something to the quality of the article which the London gas-works produce. Dr. Letheby, the inspecting chemist, has just thrown some light upon the latter difficulty. In a recent statement before the "City Court of Sewers," he has said, that "some of the companies are supplying gas, which, in the course of a few years, will tend to damage very much the atmosphere and the property in it, for it is so highly charged with sulphuret, that I am able to obtain 21 grains of oil of vitriol from 100 cubic feet." It further appears that there is in it a quantity of ammonia, holding in solution a large amount of tar, and whenever there is a leakage in the streets this oozes out. During the last half century, it has got into the public roads, and has rendered the soil offensive in the highest degree.

The use of such gas is attended with the most lamentable results. The metropolitan libraries furnish innumerable examples of books tumbling to pieces from this very cause, and perishable fabrics of all kinds are constantly undergoing more or less deterioration from the same unseen and noiseless agent. Besides this, which speaks more directly to the pocket of the London resident, there is the fatal injury to living matter; and in close, ill-ventilated rooms, which, even in these modern times of scientific applications, are still of abundant extent, the lungs of the occupants are subjected to fatal injury. To such an extent is this the case, that a chemical examination of the snow falling in London has revealed the presence of a large quantity of sulphuric acid in combination with ammonia. The autumnal drawings of leaves convey the same instructive lesson.

Now, we draw attention to these important facts—not from any desire to discountenance the further adoption of gas as a means of obtaining artificial light—for that view would be totally at variance with what we have previously advanced in this favour—but from a wish to see every possible objection to its use cleared away, as far as is practically possible. Does it not reflect something like discredit upon the great metropolitan companies, that they can be coolly told by a chemist of known reputation, that they are poisoning the atmosphere, and positively retarding their own progress by making and vending a deleterious gas?

PROGRESS OF SCREW PROPULSION—MARINE MEMORANDA.—Not long ago, between Point de Galle and the Mauritius, the crank pin of the main shaft of the engines of the *Bosphorus*, which is solid cast-iron, about a ton in weight, broke in two pieces. The engineers, under the direction of Mr. T. Turner, chief engineer, manufactured a steel plate, and ingeniously forced it, one-half into the crank, and the other half into the crank pin, in a hole one inch and three quarters in diameter, and six inches deep, which had been previously drilled to receive it. At the Mauritius a spare steel pin, two inches in diameter, was obtained; and as, on arriving at the Cape, the manufactured steel plate was discovered to be broken, it was replaced by the pin obtained at the Mauritius. Since her accident, the *Bosphorus* has been unable to steam fully; but still she arrived at the Cape thirty-six hours before her time; and on leaving St. Vincent she was eighteen hours before contract time.

A fire in New York has put a stop to all further conjecture as to the success of the gigantic American ship *Great Republic*, just finished by her most enterprising of builders, Donald Mackay. The disaster, which is said to have occasioned a loss of some £200,000, broke out in a street near the docks, and some sparks were blown thence upon the sails of the *Great Republic*. The fire, thus generated amongst the shipping, rapidly spread into other vessels, and, amongst the rest, it got into the well-known clipper *White Squall*, and completely destroyed her. The *Great Republic* was valued at £60,000, and her cargo—for she was on the point of sailing for Liverpool—was worth £55,000 more. The *New York Tribune*, in speaking of this loss, says—"The destruction of the clipper *Great Republic* is justly considered to be a public calamity. She was not only one of the most beautiful ships ever built, but her extraordinary magnitude, and the anticipations connected with her, had caused her to be regarded with something of national pride and interest. The opinion was very generally entertained that she would outstrip all competitors, and carry off the palm from the world, and her loss, just as she was about to start for the prize, sends a shock far beyond the limits of the commercial class among the great public of those who are in the habit of watching the progress of industry and enterprise in every department. Besides, she was a scientific experiment. We were to learn from her whether the speed of ships increases indefinitely in proportion to their size, or whether our builders have already reached the *maximum* of velocity, as well as the bounds of safety and economy, in nautical construction. In Europe, too, where her fame had already gone, her coming was anxiously looked for, and her untoward fate will be regretted. It is a consolation that her spirited builder and proprietor was insured, and will not suffer by the event. If he does but produce another ship like that now destroyed, he will call into existence a finer specimen of naval architecture than the world has seen from other builders in 6,000 years."

The experimental voyages to Port-Phillip and Sydney, of the General Screw Steam Shipping Company's ships, *Harbinger* and *Argo*, have been the most suc-

essful of any efforts yet made to shorten the distance between Australia and the parent country, a strange fatality having, in fact, attended the operations of every other company up to the present time. The company, encouraged by their success, are arranging a new line of steamers, for the purpose of providing regular steam communication with Australia. The first of this line, the *Crasus*, the largest merchant steam-ship which ever left the Thames, is of 2,500 tons burden, and was built by Messrs. Mare & Co., of Blackwall, who are also building three other ships of similar dimensions, to be respectively called the *Golden Fleece*, the *Jason*, and the *Prince*. The *Crasus* is built of iron, in water-tight compartments, the dimensions being as follows:—Length between perpendiculars 280 feet, length over all 300 feet, breadth 43 feet, depth 31½ feet. She is full bark rigged, with an immense spread of canvas, sufficient, with a strong breeze, to force the ship through the water (irrespective of steam power) at the rate of 13 or 14 knots. She is propelled by the auxiliary screw, and her engines, by Messrs. Rennie, are of 400 horse power, on the direct-acting horizontal principle. The screw is a two-bladed one, of 16½ feet diameter, with a 23½ feet pitch, and weighs five tons. By an ingeniously contrived hoisting apparatus, it can be disconnected and lifted bodily out of the water, so that when the vessel is under canvas alone (which will frequently be the case) no obstruction will be offered to the speed obtainable from the force of the wind acting upon the sails. The steam cylinders have a diameter of 63½ inches, and the steam is generated in four tubular boilers, so arranged that they may be used singly or collectively, according as it may be necessary or prudent to expend or economize fuel. The performance of the engines is about 52 revolutions per minute, with 16 lb. pressure of steam, and a vacuum of 27 inches in the condenser. She can carry 200 first and second class passengers; and besides the great space thus allotted, she has a capacity for 1,300 or 1,400 tons of measurement freight, will carry 1,000 tons of coals, and possesses stowage room for 300 tons of baggage and stores, with 103 tons of water in tanks, in addition to an apparatus for condensing 700 gallons of water. The qualities of the *Crasus* were tested in a trial trip down channel, which lasted three days, during which the maximum speed under canvas, with a strong breeze, and the screw disconnected, was found to be 13 to 14 knots. Close hauled, with double-reefed topsails, courses, trysail, and jib (canvas alone—no steam power applied), 10½ knots. In smooth water, with no sails, the ship steamed 10½ to 11 knots; and in coming up channel against a heavy north-east gale, with a rough sea, all yards across, the engines forced the ship through the water at the rate of 4½ to 5½ knots.

The Peninsular and Oriental Steam Navigation Company's new screw steamship *Himalaya*, of 3,550 tons and 700 horse power, was tried at the Nore, on the 11th January, when, notwithstanding the prevalence of a strong S.E. wind, the performances of the ship were satisfactory. She ran the measured mile with a current of 1½ knots in her favour, in four minutes seven seconds; being equal to 14.575 knots per hour. By the log, which was several times hove during the trip, the speed was quite 14 knots, the engines going at the rate of 56 revolutions per minute. The machinery is by Messrs. Penn and Sons.

The *Himalaya* went round to Southampton the next day, and the following is an abstract of her performances:—She left Greenhithe at 9 a.m. At Sea Reach a thick fog came on, and she was obliged to anchor for a considerable time, and on proceeding after the fog partially closed was compelled to slow her engines several times between the Nore Light and the North Foreland. She, however, performed this distance (31 miles) in just two hours. Passing round the Downs, she ran from the North to the South Foreland (17 miles), with a strong W. wind, in one hour twenty minutes. Thence to Dungeness (21 miles) in one hour thirty minutes. From Dungeness to Beachey-head (29 miles), blowing very strong from S.S.W., with a heavy swell on, and tide against her, she was three hours. Thence to abreast of the Ower's lightship (36 miles), with an increasing breeze, she was three hours thirty minutes, having to slow several times. She finally anchored in St. Helen's roads at 3 o'clock on the morning of the 13th. It was calculated that the *Himalaya* was 13 hours under way, and averaged 13½ knots per hour, which, considering the weather she met with from Dungeness to the Nab, is a very high rate of speed. She was as stiff during the breeze as could be desired, and proved herself to be one of the fastest seagoing ships afloat. Fore and aft canvas was set for a short time, during which she went fully 15 knots. At 10 a.m. on the 13th, she ran to Stoke's Bay, and tested her speed at the measured mile, with the following results:—

	M. Sec.	Knots.	
First run, with tide,.....	4 10	= 14.400	} Mean of four runs 13.844 knots per hour.
Second run, against tide,.....	4 39	= 12.903	
Third run, with tide,.....	3 54	= 15.384	
Fourth run, against tide,.....	4 56	= 12.162	

The experiments with the *Himalaya* are said to have satisfactorily demonstrated the achievement of the desideratum so long sought for in a screw-steamship, namely, the almost total absence of any vibratory motion; but we are not informed to what this is supposed to be due, or what description of screw propeller she has.

The *Himalaya* is the largest ocean steamship in the world. Registering 3,550 tons, she is equal to 4,000 tons actual burden. Over all, she measures 372 feet 9 inches; her keel is 311 feet long; breadth for tonnage, 46 feet 2 inches; and depth of hold, 24 feet 9 inches. Her cylinders are 84 inches in diameter, with a stroke of 3 feet 6 inches. Her screw is a two-bladed one, presenting no especial novelty. It is 18 feet in diameter, and 28 feet pitch, and weighs 7 tons. The hull is full ship-rigged; and, with all her canvas bent, in a stiff breeze, and full steam on, her captain talks of getting 20 miles an hour out of her.

The *Royal George* 120 gun screw steamship has been tried during her passage from Sheerness to Devonport. Messrs. Penn's 400 horse power trunk engines worked to the entire satisfaction of all on board, and the engineers who worked them, and the stokers who attended to getting up the steam, state that they never served in a ship so well ventilated and cool before. The great breadth of the ship

has allowed of the furnaces being constructed so as to give a space of 12 feet between the six furnaces on each side, and they are so arranged that there is an ample supply of pure air, although the mouths of the furnaces are nearly 60 feet below the upper deck. The average speed obtained, as nearly as possible, 10½ knots per hour, has fully confirmed the result given at her trial between the Nore and Mouse lights before she left for Devonport.

The *Fairy* screw tender to the Royal yacht, has been trying a new propeller, manufactured at the steam factory of Portsmouth dockyard, under the superintendence of Mr. Murray. The new screw is in principle similar to that of Griffiths'—the pitch, being the same, but the ball at the centre is dispensed with. Two runs were made at the mile, the average result of which gave a mean speed of 12½ knots, or one quarter of a knot less than has been obtained by Griffiths' patent itself; but the engines worked at one stroke less per minute. The *Fairy* returned, and was put on the slip the same evening, to have the central boss attached, ready for another trial.

It is understood that the new Royal yacht will be built of the following dimensions and capabilities:—Length of keel, 300 feet; length on deck, 315 feet; beam, 40 feet; depth of hold, 22 feet; diameter of paddlewheel, 30 feet 6 inches; stroke of piston, 7 feet; diameter of cylinder, 84 inches; tonnage, 2,340. The revolutions of the engines have been estimated at from 25 to 28, which will yield, it is calculated, a speed of from 15 to 16 knots per hour. The engines are to be manufactured by Penn, upon the oscillating principle, but to obtain the speed calculated upon, they must be worked upon the high-pressure system. They will occupy great space in the body of the vessel, and consequently allow of less ventilation and working room for the engineer's staff, and admit of the stowage of a less quantity of coals.

Mr. Watney, the proprietor of the Gwendraeth Works, went over to Lisbon a few weeks since in the *Brazileira*, one of the General Steam Navigation Company's large screw steamers, to superintend a trial which was being made with anthracite coal from his works. The *Brazileira* reached Lisbon in three days and twenty hours from the time of her leaving Liverpool, being the quickest passage ever made, and the trial of the anthracite was in every way successful. The *Brazileira* was on her way to the Brazils, this being her second voyage thither, which promises to even surpass the first. The *Brazileira* is Liverpool built, whilst the *Olanda*, another steamer belonging to the Brazil line, and whose mishap we noticed last month, is a Clyde built ship, and the Liverpool people are highly pleased at the superiority exhibited by the former.

REAPING MACHINES.—No sooner does one important novelty attract public attention, than it set to work a hundred differently thinking minds, and imitations, improvements, or things of a like kind, are brought forth. This has eminently been the case with regard to these machines, if we may, as we only can, judge from the number of them that have been patented in England alone. Mr. Bennet Woodcroft's "Appendix to Specifications of Reaping Machines" is very appropriately brought out just now, and will well repay perusal. In the multitude of counsellors there is safety; and from the multitude of these patents we may hope to frame hereafter—for it remains to be done, notwithstanding all the large expenditure of thought and material hitherto made—an instrument that will do its work, under such economical conditions, as will make it an acceptable and readily accessible piece of farm furniture. Claiming the original invention as English, it is a little startling to find it stated that, in the United States alone, upwards of 100 patents have been taken out on the subject. Surely here is a field—a new and comparatively untried field—for our ingenious mechanics, in which to exercise their inventive faculties to the full extent. A very large reward, indeed, because it must necessarily be a world-wide one, awaits that inventor who shall beneficially eclipse his predecessors in the path. The problem is as a gauntlet thrown down to the profession, but which should be taken up only after much study now, and careful thought and reflection. The present status of the machine has a history which must be acquired before anything rationally good can be recommended to be attempted; and this appendix goes a great way to furnish what was wanting on the subject.

CLAYTON'S BRICK-MAKING MACHINE.—The capabilities of this machine, as regards the working of stiff clay, or generally inferior material, have long been recognised by practical builders and contractors, who have largely adopted Mr. Clayton's plans for all kinds of work. Recently, Messrs. Waring, the eminent railway contractors, put the machine to a practical test upon the softest possible clay at the works, Upper Park Place, Dorset Square, with the view of positively ascertaining its behaviour under such extreme circumstances. During this trial the machine was worked by a single horse, going at a speed to suit his own direct will, without driving, and it was attended by a single unskilled labourer and two boys. After working for five minutes, Messrs. Waring stopped the horse, and found that 101 good clean bricks had been made in this time, being at the rate of 12,000 per day of ten hours. The clay was of a very rough quality, and was reduced in tenacity to the lowest point workable by hand. In Mr. Clayton's machine, the clay which issues from the die in a continuous stream, being afterwards severed into the required brick lengths, is not expressed through fixed side pieces, as is usual. Instead of this, the moulding dies are formed of rollers, and the clay is thus rolled out, producing peculiar sharpness and accuracy of form. The machine has just carried off the great prize medal from the Exhibition of Industry at Amsterdam.

GALLERY OF INVENTORS.—"Bide your time" is a simple but all-important piece of advice. It will come, depend upon it. Your time will come. The large body of inventors, dead and living, are about to have some slight honour paid to them. For a suggestion from Prince Albert to the Society of Arts, on such a topic, will necessarily soon, as we hope, be forwarded a few steps. The Prince suggests the origination of a Gallery of Inventors—a gallery of paintings, drawings, prints of those worthies who, by working with their heads alone, have placed us in the pleasant and proud position we now occupy. We are glad to find all agree in the excellence of this idea; and we trust the Society of Arts will act upon

it at once. We ourselves anticipate many an hour of calm enjoyment in the midst of the-e not sufficiently illustrious men, many, nay, most of whose properties and even lives were sacrificed upon the altar of that idea or notion which we live to see realised in all its plenitude of benefit to usward. We hear that already several noblemen and gentlemen, having authentic portraits of some of our inventors, have placed them wholly at the disposal of the society. This is an example that we shall be glad to see followed by all.

"WINGED WORDS" FOR RAILWAY DANGER SIGNALS.—Captain Norton produces four different and distinct sounds, by means of shooting his short arrows from a steel cross-bow, or from a revolver of the musket-bore size, to be discharged by the guard of a train against a Chinese gong, hung behind and over the head of the driver of the engine. The four sounds may be distinct words of command, such as "bring up," "go on," "go fast," "go slow." More sounds could be produced, but the above four are sufficient for all purposes, and more might lead to confusion. These sounds of command act like the sounds of a bugle in battle, where, from the thunder of artillery, and the long roll of musketry, no other sounds can be distinguished.

RAW MATERIALS FOR PAPER.—If ever there was a time better suited than others for the introduction of new raw materials, or the more economical employment of old ones, for paper making, that time has now reached us. For many years, the crude fibrous matters which modern scientific discovery has enabled us to work up into the white, close, even-textured fabric on which these notes are impressed, have suffered continuous exaggerations of scarcity. The world has been ransacked for the much-wanted refuse fibre, thrown aside from all conceivable quarters, and widely-sundered nations have eagerly competed in the purchases. The cheapening of popular literature, and, in a less degree, the reduction of postal costs, have each contributed immensely to the growing demand for paper, whilst every educational movement tends to the same point, and heightens the evils consequent upon the impossibility of creating a supply equal to the demand. This is felt everywhere, and many commercial nations have put an entire stop to the export of rags; and, worse still, the Americans—powerful rivals in such a matter—have stepped into our own markets to bid against us for our own waste materials. Paper is generally understood to be made merely of rags; but such materials furnish but a small portion of what is really employed in the manufacture. Cotton and flax-mill sweepings, old ropes, bale coverings, straw, and some ligneous fibres, all work up into good paper. But even all the economical collection which we have been able to make has not averted the evil of scarcity, and a new and cheap material was never so much in request as at this moment. "Let every merchant," says a sensible writer in the *Times*, "direct the attention of his foreign agents to the discovery of a cheap fibrous material, and the transmission of specimens in sufficient quantity for trial, and let every housewife preserve what she may hitherto have destroyed in linen or cotton fibre, if for no other reason than to aid in supplying the necessary material for transmitting that intellectual food without which an intelligent nation would indeed starve."

SOCIETY OF ARTS.—During the last quarter of the last year, this venerable society, which is sensibly becoming one of the most important institutions of the realm, has taken into union so many new and additional scientific institutes of all descriptions, as to have increased the number in union to 319. A centralization of this kind promises well to the country at large, and bids fair, by the exercise of appropriate and wholesome means, to attain the great end the society has in view.

COVERING FOR SMITHFIELD MARKET, MANCHESTER.—The Manchester Smithfield Market, which has hitherto been roofless, is now being covered in with a roof of iron, slate, and glass. The area is about 2½ acres, and this great space has 72 supporting columns upon it, the roof resting upon them being of the class now commonly used for the principal railway stations. It is of iron, supported by seven girders, resting on the flange of an iron guttering running from column to column longitudinally. The ridge of the roof in the inner bays is 42 feet from the ground; in the others, it is 36 feet; and it is covered with glass for 14 feet on each side of the ridge, the rest being slated. The drainage is effected on the tubular system, a line of tubing running down the centre of each bay, the water on the surface of the market being conveyed to these ducts by gutters, whilst that from the roof descends by the tubular columns. Water is supplied to the market by a main service pipe, running right down the centre from north to south—and three branches, each with three stand pipes, run right and left from this main channel. These details are so arranged, that the whole surface can be well washed by attaching hose, to the stand pipes. At each end of the rows of columns, is a square paneled pillar; and these pillars, and all the columns, have foliated capitals. The ends of the bays are closed with one framing, glazed with sheet glass, and resting upon elliptical arches, springing from the columns. On the side of a new thoroughfare, called Oswald Street, elliptical moulded arches spring from the columns, with perforated spandrels, and a cornice above. The columns extend up to the cornice, with square paneled blocks, surmounted by external pateræ and escutcheons. The design is by Mr. James Heywood, of the Phoenix Foundry, Derby, who is the contractor for the roof; and the works are being executed under the superintendency of Mr. W. Fairbairn, at whose recommendation, the committee adopted Mr. Heywood's plan.

NOTTINGHAM FRAMEWORK KNITTING.—The complicated varieties of goods manufactured in the Nottingham, Leicester, and Hinckley districts, by what is known as "framework knitting"—as gloves and hosiery—owe much to recent mechanical improvements. The "circular frames," in particular, have received many perfecting touches; and the latest modifications have already quite distanced the machines made only a year or two ago, both as regards quantity of production and quality of work, whilst the first cost is no more than one-half that of the superseded contrivances. So far, a machine to make "fashioned" goods by steam power has been much wanted. Messrs. Harris, of Leicester, have introduced

Mr. Mowbray's patented machine for this purpose; and, as far as it goes, this invention is a real improvement, although it seems more especially suited for heavy woollen goods. Mr. Haywood, of Nottingham, has also since contrived a frame for a similar purpose; and Messrs. Hine, Mundells, & Co., of Nottingham, have contributed two separate arrangements, which promise important results. One of Messrs. Hine's machines has been expressly designed for fashioning, or narrowing differentially by power, without stoppages. The other is an improvement upon the machine employed for making the old Derby rib. This substitution of mechanical power for manual labour, as in all parallel cases, has materially augmented the manufacturing capabilities of the extensive district concerned in this trade.—The lace manufacture of Nottingham has lately received an enormous increase of development. The extension has indeed been such, that cotton spinning and doubling mills have begun to spring up in the neighbourhood for the purpose of supplying the raw material for the more elaborated manufacture. A mill of this kind has just been built, and set to work, by Mr. John Morley, in a style capable of fair comparison with the finest establishment of Lancashire.

CENTRAL SCHOOL OF ART, MARLBOROUGH HOUSE.—The School of Design which Government lately maintained at Somerset House, having proved a failure, has ceased to exist, and a new school, called the Central School of Art, has been opened at Marlborough House, under a different system. This school is attached to the department of Art and Science of the Board of Trade, and its superintendent is Mr. Redgrave, R.A. It consists of three divisions:—I. A model school, in which lectures, teaching, and practice, daily go forward in freehand, model, and elementary mechanical drawing, practical geometry and perspective, painting in oil, tempera and water colours, and in modelling. Each student pays £4 for the session of five months. Evening instruction is given in advanced drawing, painting, and modelling, including the figure. £2 are paid for the session, except by qualified students, formerly registered at Somerset House, who are admitted on payment of a fee of £1. 10s.—II. Special classes for technical instruction, having reference to, 1, practical construction, (architecture, building, plastic decoration, furniture, metal working); 2, mechanical and machine drawing; 3, surface decoration, as applied to woven fabrics, lace, paperhangings, &c.; 4, porcelain painting; 5, wood engraving; 6, lithography—chalk, pen, and colour. The fee for each course is £4, except as to No. 2, where the fee is £2. In some cases, there is evening instruction with a fee of £2.—III. A training school for teachers. A class for the instruction of schoolmasters and pupil teachers meets on two evenings of the week, and on Saturday. The fees are 10s. for the session for pupil teachers, and for masters of parochial schools, and similar parties, 5s.—Lectures are delivered in connection with the objects for which the Central School of Art has been established, by Professor E. Forbes and other persons. To these lectures the public is admitted by a payment of 6d. each lecture.—The museum and library at Marlborough House are placed at the service of the students, who are allowed to matriculate for a term of three years, upon payment of £20, in one sum, on entrance, or by three annual payments of £10. They are then entitled to attend all public and class lectures, the general and technical courses, to receive personal instruction, and to practice in the school at all times.—"In closing its rooms at Somerset House," says the *Times*, "the department virtually abandons the task of direct teaching in the early stages of practical art education. Its efforts are now confined to the training of masters, and to instruction in the higher branches of design. For these purposes regular courses of tuition are prescribed, and lectures given by competent professors, the students possessing the additional advantage of the museum and library for consultation and reference. The museum is extending with a rapidity which will soon force upon Government the necessity of finding a more suitable home for it than the small, inconvenient, and mean apartments of Marlborough House. Though still in its infancy, it possesses extreme interest; and from the comprehensive classification of objects included in it, it is certain, at no distant period, to equal, if it does not excel, anything of the kind in Europe. No one with a true perception of the beautiful, as applied to the industrial arts, can visit it without being highly gratified. In metal work, in ceramic manufactures, in lace, in textiles, in furniture, it contains a small, indeed, but an exceedingly choice and valuable selection of specimens and examples. The library is a still more recent creation than the museum, and though less attractive to the general public, not inferior in utility. It already comprises several thousand volumes, and is a place to which manufacturers engaged in ornamental production may resort with great benefit to themselves; for as long as the peaceful arts have flourished on the earth, and considering what important aids books could lend them, it is surprising how little that aid has hitherto been sought, and how few attempts have been made, and how few materials exist for forming a special library of the kind now open at Marlborough House. The astonishing progress of photography, added to the facilities which other beautiful and cheap processes afford, will soon enable us to wipe away this reproach."

PROVISIONAL PROTECTIONS FOR INVENTIONS UNDER THE PATENT LAW AMENDMENT ACT.

When the city or town is not mentioned, London is to be understood.

Recorded August 13.

1900. John Gwynne, Essex-wharf, Essex-street, Strand—Improvements in the preparation of a black powder from coal, and the application thereof to the manufacture of paints, blacking, and various other purposes.

Recorded October 5.

2276. William Crofts, Derby-terrace, Nottingham Park—Improvements in the production of figuring in weaving.

Recorded October 6.

2290. Charles A. Holm, 21 Cecil-street—Improvements in machinery for raising or propelling elastic and non-elastic fluids.

Recorded October 19.

2406. Gustavus Gidley, 43 Robert-street, Hoxton, and John B. Muschamp, Kensington—An improvement in making india-rubber solution for waterproofing cloths or other articles, without the offensive smell produced by the use of naphtha, turpentine, oils, &c.

Recorded October 24.

2452. Edward J. M. Archdeacon, Gravel-lane, Southwark—An improved method of indicating places, divisions, or contents, in directories.

Recorded October 27.

2486. George E. Dering, Lockleys, Hertfordshire—Improvements in galvanic batteries.

Recorded November 21.

2701. Aaron Parfitt, Newbury, Berks—Improvements in the construction of certain descriptions of vehicles.

2706. William Joyce, Greenwich, and Thomas Meacham, same place—Certain improvements in marine steam engines.

Recorded November 22.

2710. William Mee, Leicester—Improvements in the manufacture of braces.

Recorded November 25.

2741. Alexandre A. V. Sarrazin de Montferrier, Paris, and 4 South-street, Finsbury—Improvements in wheels for vehicles on common roads and railways.

Recorded November 28.

2771. John C. Ramsden, Bradford—Improvements in apparatus, or the mechanism of looms, for weaving a certain class of plaids, checks, and fancy woven fabrics.

Recorded November 29.

2776. Edward J. Hughes, Manchester—An improved method of purifying and concentrating the colouring matter of madder, munnjeet, spent madder, or any preparations thereof, however they may be made.

Recorded November 30.

2781. Joshua Jackson, Wolverhampton—A new or improved signalling apparatus.

2782. John Elce, Manchester—Certain improvements in machinery for spinning.

2783. Peter A. Le Comte de Fontaine Moreau, Paris, and 4 South-street, Finsbury—Certain improvements in the construction of the Jacquard machine.—(Communication from Mr. R. Ronze, Lyons.)

2784. Edward K. Davis, 1 Howley-street, Lambeth—Improvements in machinery for making pipes, sheets, still-worms, and other articles, from that class of metals called soft metals, as lead, tin, zinc, bismuth, or alloys of soft metals, that are capable of being forced out of metal receivers or chambers, through dies, cores, &c.

2785. John Hewitt, Salford—Certain improvements in machinery or apparatus for spinning cotton and other fibrous substances.

2786. Joseph Redford, Pilkington, near Manchester—Certain improvements in power-looms.

2787. Richard Balderston, Blackburn—Improvements applicable to spinning machines, known as mules, and to machines of similar character, for clearing or cleaning certain parts of such machines.

2788. John Paterson, Beverley, York—Improvements in land rollers or clod crushers.

2789. Alphonse Louhat, Paris—Improvements in the construction of tramways.

2790. Lewis Jennings, Fludver-street, Westminster—An improved mode of producing plain and ornamental sewing, and in machinery applicable thereto.

2791. Norbert de Landtsheer, Ghent, Belgium—Improvements in machinery for combing flax or other fibrous material.

2792. Francis S. Cole, Chilton, Surrey—A smoke-consuming apparatus for enabling every fire to consume its own smoke.

Recorded December 1.

2793. Thomas Garnett, Low-moor, near Clitheroe, Lancashire, and Daniel Adamson, Dukinfield, Cheshire—Improvements in generating steam, and in consuming smoke.

2794. Augustine E. L. Belford, 16 Castle-street, Holborn—Improvements in machinery for manufacturing horse shoes.—(Communication.)

2795. Alfred J. Jones, New Oxford-street—An improved cigar light.

2796. Joseph Dilworth, Preston—Improvements in escape valves and safety valves.

2797. Thomas Hollinsworth and John Hollinsworth, Winwick, near Warrington—Certain improvements applicable to "alarm whistles" to be used upon railways, or as signals where otherwise required.

2798. John H. Johnson, 47 Lincoln's-inn-fields, and Glasgow—Improvements in the treatment or manufacture of caoutchouc.—(Communication from Charles E. F. Guihal and Louis P. B. E. Cumenge, Paris.)

2799. John H. Johnson, 47 Lincoln's-inn-fields, and Glasgow—Certain applications of vulcanized india-rubber.—(Communication from Charles E. F. Guihal, Paris.)

Recorded December 2.

2800. James Reilly, 56 Thomas-street, Manchester—Improvements in machinery or apparatus for tenoning, mortising, and sawing wood, metal, or other materials.

2801. Arthur W. Callen, Peckham—An improved excavating and dredging machine.—(Communication.)

2802. Augustine E. L. Belford, 16 Castle-street, Holborn—Improvements in hlocks for ships' and other uses.—(Communication.)

2803. Henry Deacon, Widnes, and Edmond Leyland, St. Helen's, Lancashire—Improvements in apparatus for the manufacture or production of sulphuric acid.

2804. Alexander Brown, Glasgow—Improvements in metallic casks and other vessels.

2805. George Williamson, Glasgow—Improvements in applying motive power.

2806. Alexander Bain, Paddington—Invention of an apparatus for damping paper and other substances, in order to prepare the same for the reception of labels, stamps, and other like articles coated with a gummy or adhesive matter.

2807. John C. Wilson, Redford Flax Factory, Thornton, Kirkcaldy—Improvements in machinery for scutching flax, hemp, and other fibrous materials.

2808. George Collier, Halifax—Certain improvements in looms for weaving.

2809. Robert Keyburn, Greenock—Improvements in sugar refining.

2810. Samuel C. Lister, Bradford—Improvements in combing wool, hair, cotton, and other fibrous materials.

2811. Henry Bessemer, Baxter-house, Old St. Pancras-road—Improvements in the manufacture and refining of sugar.

2812. Jonathan Saunders, St. John's-wood—Improvements in the manufacture of rails for railways.

Recorded December 3.

2813. Charles E. Green, 13 Blandford-street, Portman-square, and John Bayliss, 34 Parliament-street—Improvements in machinery to save persons and property in

case of fire, which machinery may also be applied for the purpose of raising and lowering weights of any kind, also for the purpose of compression, and for other useful purposes.

2814. Abraham Rogers, Bradford—Improvements in ventilating sewers, mines, or other subterranean works.

2815. Charles Buck, Wellington, Somersetshire—An improved apparatus for retarding or stopping the progress of wheel carriages.

2816. William Dray, Swan-lane—Improvements in the construction of portable houses and buildings.

2817. John Gwynne and James E. A. Gwynne, Essex Wharf, Strand—Improvements in the manufacture of fuel, its preparation and applications for the reduction of ores, fusing and refining metals, cementation or making steel, and treating salts.—(Partly a communication.)

2818. Henry J. Life and James Newman, Birmingham—Certain improvements in the construction of metallic bridges and other similar structures.

Recorded December 5.

2820. Squier Cheavin, Spalding, Lincolnshire—Invention of a double-action or belt-filterer.

2821. Benjamin Skillman, Crosby-hall-chambers—An improved mode of preparing sheets of paper suitable for postal communication.

2822. William Simons, Glasgow—Improvements in propelling and steering vessels.

2823. Matthew A. Muir, Glasgow—Improvements in check and fancy weaving.

2824. John Patterson, Beverley, York—Improvements in reaping machines.

2825. Thomas Storey, Phoenix Foundry, Lancaster—Improvements in the construction and arrangement of apparatus employed in connection with sewers.

2826. James Robertson, Kentish-town—Improvements in the consumption or prevention of smoke.

Recorded December 6.

2828. Edward Oldfield, Salford—Improvements in machinery for spinning and doubling.

2829. John C. Haddan, Chelsea—Improvements in the manufacture of cartridges and of wads or wadding for fire-arms.

2831. Augustine E. L. Belford, 16 Castle-street, Holborn—The manufacture of an artificial tartaric acid, and the application of the same to useful purposes.—(Communication.)

2833. Thomas Mills, Leicester—An improvement in the manufacture of lined gloves.

2834. William E. Gaine, 4 Harewood-street, Harewood-square—An improvement in treating or preparing paper.

2835. Robert C. Witty, 1 Portland Place, Wandsworth-road, Surrey—Improvements in the construction of boiler and other furnaces.

2836. John H. Johnson, 47 Lincoln's-inn-fields, and Glasgow—Improvements in printing oil cloths and other fabrics.—(Communication.)

2837. Julian Bernard, 15 Regent-street—Improvements in machinery or apparatus for stitching or uniting and ornamenting various materials.

2838. John Hargrave, Kirkstall, Yorkshire—Certain improved apparatus for washing and scouring wool.

2839. Alfred V. Newton, 66 Chancery-lane—Improvements in fire-arms and ordnance.—(Communication.)

Recorded December 7.

2840. William Slater and Robert Halliwell, Bolton-le-Moors—Improvements in machinery for spinning.

2841. Lewis H. Bates, Bradford—Improvements in machinery for stamping and cutting metal nuts and other similar metal articles.

2843. John Getty, Liverpool—Improvements applicable to the plating of iron ships, part of which improvements is also applicable to the construction of boilers.

Recorded December 8.

2844. William G. Reeve, Elizabeth-street, Eaton-square—An appendage to horse shoes to supersede the necessity of roughing them, as hitherto practiced.

2845. William B. Adams, 1 Adam-street, Adelphi—Improvements in railway wheels, their axles and boxes.

2846. William T. Henley, St. John-street-road—Improvements in electric telegraphs.

2847. Thomas Moran, Dublin—Improved means or apparatus for the prevention of accidents on railways in certain cases.

2848. Benjamin Solomons, Alhmarle-street, Piccadilly—Improvements in telescopes and other glasses in their application to the measurement of distance.

2849. William C. Jay, Regent-street—An improved cloak.

2850. Joseph Goddard and Charles Yates, Tottenham-court-road—Certain improvements in machinery or apparatus for obtaining and applying motive power.

2851. Joseph Robinson, Carlisle—Improvements in mills for grinding corn and other substances.

2852. John Nelson, Selby, Yorkshire, and David Boyd, same place—Improvements in scutching flax and hemp.

2853. James Beall, Cheshunt, Herts—Improvements in apparatus for applying sand to the rails of railways.

2854. William E. Newton, 66 Chancery-lane—Improved machinery for drilling or boring rocks and other hard substances.—(Communication.)

2855. Philippe J. T. Bordone, Paris—Improvements in extracting and treating the juice of beetroot and other vegetables.

2856. Mareel G. Laverdet, Paris—An improved mode of treating photographic pictures.

2857. Benjamin Murgatroyd, Bradford—Improvements in washing or scouring wool, and fabrics composed entirely or partly of that material.

Recorded December 9.

2858. Jean B. E. Rüttre, Paris, and 5 Lawrence Pountney-lane—Improvements in machines for producing shoddy from woven fabrics, and for sorting the fibres of fibrous materials.

2859. Pierre M. Fouque, Louis R. Hébert, and Vincent E. D. le Marneur, Paris, and 5 Lawrence Pountney-lane, Cannon-street—Improvements in rudders.

2860. Arthur James, Redditch, Worcestershire—Improvements in counting, measuring, and weighing needles, and in preparing papers to receive the same.

2861. Duncan Christie and John Cullen, 1 Bromley High-street—An atmospheric counterbalance slide-valve for the steam-engine, hydraulic, and all other machines in which the slide-valve is used or required.

2862. Andrew Shanks, 6 Robert-street, Adelphi—Improvements in instruments and apparatus for indicating or measuring weights and pressures.

2863. Charles Muckenzie, Bayswater, Middlesex, and Alexander Turnbull, Manchester square, do.—Machinery for paring fruit and vegetables.—(Communication.)

2864. John Winspear, Liverpool—An improved mode of coating metals, wood, stone, and plaster to preserve them from decay.

2865. Richard Eccles, Wigan, John Mason, Rochdale, and Leonard Kahery, Rochdale—Improvements in slubbing and roving frames for cotton and other fibrous substances.

2866. James Sutcliffe, Manchester—Improvements in steam-engines and in apparatus connected therewith.

2867. Frederick Osbourn, Aldersgate-street—Improvements applicable to the distribution of manure.

2868. John Chisholm, Holloway—Improvements in the distillation of organic substances, and in obtaining products therefrom.

2869. John H. Johnson, 47 Lincoln's-inn-fields, Middlesex, and Glasgow—Improvements in portable cases for containing provisions.—(Communication from Alexandre D. E. Beucher, Paris.)
2870. Gideon Morely, Birmingham—Ornamenting or producing pictures on japanned goods, panels, canvass, or other material, whereby a vast amount of artistic skill and labour is superseded.
2871. William Schaeffer, Stanhope-terrace—Improvements in purifying spirit.
2872. John Bourne, Port-Glasgow—Improvements in steam-engines.
2873. John Bourne, Port-Glasgow—Improvements in machinery for the production of iron ships and other similar structures.
2874. John Bourne, Port-Glasgow—Improvements in the construction of iron ships.
2875. Henry Bessemer, Baxter House, Old St. Pancras-road—Improvements in the construction of railway axles and breaks.

Recorded December 10.

2876. Allan Macpherson, Brussels—Improvements in disinfecting sewers or other drains or depositories of fetid matters or gases, and in converting the contents thereof to useful purposes.
2877. William Muir, Britannia Works, Manchester—Improvements in machinery and apparatus for cutting out parts of garments.
2878. Charles Coates, Sunnyside, near Rawtenstall, Lancaster—Improvements in and applicable to looms.
2879. Hippolyte L. Du Bost, 62 Rue Neuve des Petits Champs a Paris, and 21 New-street, Covent-garden—Improvements in the construction of locks and keys.
2881. John H. Johnson, 47 Lincoln's-inn-fields, Middlesex, and Glasgow—Improvements in furnaces for the manufacture of steel.—(Communication.)
2882. Edward Green, Wakefield, York—Improvements in boilers and furnaces.
2883. Nicolas V. Guibert, Paris, and 4 South-street, Finsbury—Improvements in forge hammers.
2884. William Thornley, Clayton West, York—An improved manufacture of woven fabrics.

Recorded December 12.

2885. Edward O. W. Whitehouse, Brighton—Improvements in effecting telegraphic communications.
2886. Thomas Hollinsworth, Winwick, near Warrington—Certain improvements in the method of applying breaks to carriages employed upon railways, and in the machinery or apparatus connected therewith.
2887. William Evans, Myrtle-street, Hoxton—Improvements in obtaining and applying motive power.

Recorded December 13.

2888. William Redgrave, Croxley-green, Rickmansworth—Improved safety travelling cap.
2889. George K. Hannay, Ulverston, Lancashire—The combination and manufacture of composition grinding wheels, bones, and other grinding bodies.
2890. James Wansbrough, Grove, Guildford-street, Southwark—Improvements in the manufacture of waterproof fabrics.
2891. William F. Plimmer, St. Mary's Overy Wharf, Southwark—Improved machinery for grinding or crushing animal, vegetable, and mineral substances.
2892. Christian Schiele, North Moor Foundry, Oldham—Improvements in preventing undue oscillation in engines, machinery, carriages, and other apparatus.
2893. André G. Guesdron, Montmartre, Paris—Improvement in or addition to sugar basins.
2894. André G. Guesdron, Montmartre, Paris—Method of producing plans in relieve.

Recorded December 14.

2895. Philip Grant, Manchester—Improvements in printing presses.
2896. Frederick A. Gatty, Accrington, Lancaster, and Emile Kopp, Accrington, aforesaid—Improvements in printing and dyeing cotton, wool, silk, and other fibrous substances.
2897. John A. Coffee, Providence-row, Finsbury—An improved method of evaporating liquids.
2898. Edward Beanes, 57 Charlotte-street, Portland-place—Improvements in the manufacture and refining of sugar.
2899. John Z. Kay, Dundee—Improvements in gas meters.
2900. Benjamin Fullwood, 23 Abbey-street, Bermondsey—Certain improvements in the manufacture of cement.
2901. John Wibberley, Eagle, near Bolton—Certain improvements in machinery or apparatus for winding yarns or threads on to spools or bobbins.
2902. Richard J. N. King, Exeter—An improved artificial bait for fish.
2903. Robert Parrock, Glasgow—Improvements in coats and similar articles of dress.
2904. William B. Johnson, Manchester—Improvements in machinery or apparatus for making bricks and other articles from clay and other plastic materials.

Recorded December 15.

2905. Engéne H. Rascol, Catherine-street, Strand—Improvements in retorts for the manufacture of gas.—(Communication.)
2906. Samuel Messenger, Birmingham—An improvement or improvements in railway, ship, and carriage lamps.
2907. Thomas Pugh and William Kennard, King-street, Snow-hill—Improvements in lock and latch spindles.
2908. Joseph B. Howell and John Shortridge, Sheffield—Improvement or improvements in the helves of till hammers.
2909. Jacques P. H. Vivien, Paris, and 16 Castle-street, Holborn—Certain improvements in the manufacture of paper and pasteboard.
2910. Auguste E. L. Belford, 16 Castle-street, Holborn—Improvement in blasting powder for mining, and other operations of a similar nature.—(Communication.)
2912. Jean B. Pascal, Lyons, and 16 Castle-street, Holborn—Certain improvements in obtaining motive power.
2913. Frederick W. Branton, Oak Tree House, Clapham—Improvements in certain tablets, labels, and signs, or their surfaces exhibiting letters and designs.
2914. Charles J. Morris, Kirby-street, Hatton-garden—Certain improvements in hook-binding.
2915. Benjamin Whitaker, Brighton—Improvements in the manufacture or production of useful toys.
2916. Alexander Cochran, Kirkton Bleach Works, Renfrewshire—Improvements in the application of starch or other substances of a similar nature to woven fabrics and in the machinery or apparatus employed therein.
2917. Ferdinand D. Gibory, Paris—Improvements in instruments for ascertaining heights and distances for levelling.
2918. Arthur B. S. Redford, Albion-place, Walworth-road, and Thomas Cloake, Saville-row, Walworth-road—Improvements in retarding and stopping the progress of railway carriages.

Recorded December 16.

2919. William Binnion, Birmingham—Improvements in carriage and other lamps.
2920. Walter G. Whitehead, Birmingham—Improvement or improvements in hats, caps, bonnets, and other coverings for the head.
2921. William Tranter, Birmingham—Certain improvements in fire-arms, and in bullets and wadings to be used therewith.
2922. Antoine Limousin, Paris, and 5 Lawrence Pountney-lane—Improvements in looms for weaving pile fabrics, and in a mode and apparatus for cutting the pile.

2923. Alphonse Médail, Paris, and 4 Trafalgar-square, Cbaring-cross—An improved hydraulic machine.

2924. Thomas Williams, Liverpool—An improved revolving pistol.
2925. Thomas S. Truss, Cannon-street—Improvements in brakes for railway carriages and other vehicles.
2926. Thomas S. Truss, Cannon-street—Improvements in apparatus for communicating between the driver and the guard of railway trains.
2927. John H. Johnson, 47 Lincoln's-inn-fields, and Glasgow—Improvements in dyeing.—(Communication from Monsieur Bellancourt, Rheims.)
2928. John H. Johnson, 47 Lincoln's-inn-fields, and Glasgow—Improvements in the treatment or preparation of wool, and of the wash waters employed in such treatment.—(Communication from Messieurs Villermet and Mannheim, Paris.)
2929. Stephen Norris, New Peter-street, Horseferry-road—Improvements in lighting and extinguishing gas lamps.
2930. Samuel Smith, Horton Dyeworks, near Bradford—Improvements in preparing rovings and yarns of wool.
2931. Alexander Parkes, Birmingham—Improvements in separating silver from its ores or other compounds.
2932. Robert B. Hall, Whitecross-street—Improvements in crushing and grinding quartz, minerals, and other matters.
2934. Andrew L. Knox, Glasgow—Improvements in ornamenting certain descriptions of textile fabrics.
2935. Henry Thomson, Chitheroe—Improvements in machinery or apparatus for stretching textile fabrics as they are wound into laps or rolls after the processes of bleaching and dyeing, or operations connected therewith.
2936. Robert W. Waltham, Bentham House, Yorkshire—Improvements in belts or bands for driving machinery for use in mines, and for other purposes.

Recorded December 17.

2937. Joseph S. Bailey, Keighley—Improvements in machinery for operating upon wool, alpaca, mohair, and other fibrous materials, preparatory and prior to being spun.
2938. Joshua Horton, Birmingham—Improvements in the manufacture of certain kinds of metallic vessels.
2939. George Anderson, Rotherhithe—Improvements in apparatus used when manufacturing gas, which apparatus, or part of which, is also applicable when transmitting gas from one place to another.
2940. Caleb Bedells, Leicester—Improvements in the manufacture of elastic fabrics.
2941. John D. M. Stirling, Larches, near Birmingham—Improvements in the manufacture of iron.
2942. John Greenwood, 10 Arthur-street West—Improvements in preventing drafts of air into rooms and places where the doors and windows are shut.
2943. Isaac James, Cheltenham—Improvements in carts for distributing water or liquid manure.
2944. Matthew P. Houghton, Hillmorton, Warwickshire, and Andrew Stewart, same place—An improved means of preventing accidents upon railways.
2946. Robert Whewell, Little Bolton, Bolton-le-Moors—Improvements in machines used for cutting paper.

Recorded December 19.

2947. Henry Milward, Redditch—New or improved machinery for manufacturing needles and fish hooks.—(Communication.)
2948. John Tribelhorn, St. Gall, and Dr. Pompejus Bolley, Aarau, Switzerland—Improvements in the process of bleaching vegetable fibrous substances.—(Communication from Charles Custer, Switzerland.)
2949. Auguste E. L. Belford, 16 Castle-street, Holborn—Improvements in paddle-wheels for propelling vessels.—(Communication.)
2950. William Crossby, Devonshire-street, Sheffield—Invention for the ventilation of granaries, storehouses, or places of deposit for grain whatsoever, and for improvements in the grinding of grain and dressing of grist, and grinding generally.
2951. Auguste E. L. Belford, 16 Castle-street, Holborn—Certain improvements in presses for expressing oil or other fluids from fruits, grains, or other substances.—(Communication.)
2952. Richard Waygood, Newington-causeway, Surrey—Improvements in portable forges.
2953. David Goldthorp, Cleckheaton, near Leeds—An improved propeller.

Recorded December 20.

2954. Adam Paterson, Westminster—An improved cooking apparatus.
2955. James H. Campbell, 1 King's-arm-yard, Coleman-street—Improvement in machinery for cutting corks.
2956. Josiah Latimer Clark, Chester-villas, Islington—An improvement in insulating wire used for electric telegraphs, with a view to obviate the effects of return or inductive currents.
2957. Henriette E. F. De Gergy V. Durut, Paris—Certain improvements in the manufacture of bread.
2958. Paul Wagenmann, Bonn, Rhenish Prussia—Improvements in the manufacture of liquid hydro carbons and paraffine.
2959. James Boydell, Gloucester-crescent—Improvements in the manufacture of wrought-iron frames.
2960. Emile V. F. Lemaire, 2 Rue Drouot, Paris—Improvements in tanning.
2961. John Webster, 3 Cornwall-road, Stamford-street—Improvements in acting on drying oils and preparing varnishes.
2962. James Burrows, Haigh Foundry, near Wigan—Certain improvements in the formation of such metallic plates as are required to be conjoined by riveting or other similar fastening.
2963. James Burrows, Haigh Foundry, near Wigan—Certain improvements in the construction of steam boilers or generators, and in the arrangement of furnaces connected therewith.
2965. R. B. Huygens, Holland, now 89 Cbanery-lane—Improvements in machinery for crushing, washing, and amalgamating gold, and other ores and substances.

Recorded December 21.

2966. Gottlieb Boccus, Hammersmith—Certain apparatus adapted to the breeding and rearing of fish.
2967. Charles J. Farrington, Hampstead—Improvements in signalling and preventing collisions on railways by electrical communication.
2968. Heiman Kohnstamm, 7 Union-court, Old Broad-street—Certain improvements in the manufacture of imitation leather.
2969. Thomas V. Lee, 5 Bedford row, Dublin—Improvements in the construction of certain machinery and apparatus for the manufacture of bricks and tiles.
2970. James Dinning and William Inglis, Southampton—An improved apparatus for purifying and filtering residuous water.
2972. John Jones, Glasgow—Improvements in governors or regulators for steam-engines and other machinery.

Recorded December 22.

2973. John Youll, Burton-upon-Trent—Improvements in the mode or method of obtaining power to raise liquids, and of treating the said liquids when raised, and of using them to obtain additional power.

2974. Louis A. F. Besnard, Paris, now in Essex-street, Strand—Invention of a new system of painting, by means of lithography, without leaving a particle of paper on the canvass.
2975. Peter A. Le Comte De Fontaine Moreau, 4 South-street, Finsbury, and 39 Rue de l'Échiquier, Paris—Certain improvements in constructing and applying connecting-rods.—(Communication.)
2976. William H. Woodhouse, Parliament-street, Westminster—Improvements in the construction of roads, ways, and ducts.
2977. Charles Lewis, Hull—An improved lamp for signalling
2978. Benjamin Murgatroyd, Bradford—Improvements in washing or scouring wool, alpaca, and mohair, and fabrics composed entirely or partly of those materials.
2979. Thomas Berry, Rochdale, James Mangnall, Heywood, and John Chadwick, Heywood—Improvements in winding and twisting wool, cotton, and other fibrous materials.
2980. James Gibbons, jr., Wolverhampton—Improvements in locks and latches.
2981. Joseph Shaw, Hatton-garden—Improvements in pianofortes.—(Communication.)

Recorded December 23.

2982. John Gillow, jun., Norwich—Certain improvements in the manufacture of salt.
2983. John Britten, Birmingham—Improvements in girders, bridges, roofs, and other such like structures.
2984. John O'Neil, Bury—Improvement in apparatus for drawing condensed steam and air from pipes, or other chambers, in which steam is used.
2985. Francis Bennoch, Wood-street, Cheapside—Improvements in coating silk and other yarn or thread with gold or other metal.—(Communication.)
2986. Jean D. Pfeiffer, Paris, and 4 South-street, Finsbury—Improvements in machinery or apparatus for cutting paper and similar materials.

Recorded December 24.

2987. Richard G. Coles, Cheltenham—Improvements in the locks of fire-arms.
2988. Joseph Gantier, Paris, and 4 South-street, Finsbury—An improved apparatus for washing and bleaching.
2989. George Goutaret, Paris, and 4 South-street, Finsbury—A new system of propulsion.
2990. Joshua Margerison, Preston—Improvements in railway breaks.
2991. Harris Harbidge, New York—Invention for manufacturing liquid quartz or silice, to be used in the manufacture of certain compositions for ornamental and useful purposes.
2992. Gustav A. Buchholz, Gould-square, Crutched-friars—Improved machinery for the cleaning and hulling, or dressing of rice, wheat, or other grain.
2993. Joseph Lewis, Salford—Improvements in apparatus for drilling or boring metals and other substances.
2994. Thomas Cooper, Leeds—Improvement applicable to the binding of ledgers and other books.

Recorded December 27.

2995. Thomas W. Makin, Manchester—Improvements in machinery or apparatus for finishing woven fabrics.
2997. Frederick C. Calvert, Manchester—Improvements in the treatment of naphthas and other volatile hydrocarbons, and in the application of the same to various other purposes.—(Communication.)
2998. George J. Mackelan, Lechlade, Gloucester—Improvements in winnowing or corn-dressing machines.
2999. Samuel Sedgwick and Thomas Dawson, 136 Piccadilly—Improvements in the moderator lamp, or in lamps of a similar principle.
3000. Thomas S. Prideaux, St. John's Wood—Improvements in apparatus for regulating the supply of air to furnaces, and for preventing radiation of heat from fire doors and other parts of the fronts of furnaces.
3001. Thomas Molyneux, Manchester—Certain improvements in winding and doubling silk, a part of which improvements is applicable to the treatment of other fibrous substances.

Recorded December 28.

3002. John Parkinson, Bury—Improvements in governors for regulating the pressure of steam, gas, and other fluids or liquids.
3003. John Moffat, Heiton, Roxburgh—Improvements in the means of communication between the guard and the engine driver in a railway train.
3004. James Taylor, Birkenhead—Certain improvements in raising and lowering weights.
3005. William U. Coates, Ombersley, Worcester—Improved rotatory steam-engine.
3006. Joseph Alexis, Avignon, France—Improved railway break.
3007. Richard Green, of the firm of Davis, Greathead, and Green, Flint Glass Works, Brettell lane, Stafford—Improvements in insulators for insulating the wires or rods employed for conducting or transmitting electricity.
3008. John Mackintosh, 12 Pall Mall, East—Improvement in discharging projectiles.
3009. John Barnes, Church, Lancashire—Improvements in dyeing and cleansing cotton, silk, wool, and other fabrics.
3010. Francis Parker, Northampton—Improvement in the manufacture of gaiters.
3012. Duncan M'Nee, Kirkintilloch, and Alexander Broadfoot, 128 Ingram-street, Glasgow—Improvements in printing with colours on cloth, which are also applicable to printing ornamental designs on paper and other surfaces.
3013. Thomas Phillips, jun., Sparkbrook, Warwick, and Samuel Phillips, Birmingham—Improvements in the construction of window shutters, which improvements are also applicable as an additional security for doors and other similar openings.

Recorded December 29.

3014. Henry Jackson, High street, Poplar—Improvements in machinery for moulding bricks and other articles of brick earth.
3015. Edward Estivant, Givet, France—Improvements in the manufacture of tubes of copper and its alloys.
3016. Mary Phillips, Birmingham—Improvement or improvements in metallic revolving or winding shutters.—(Communication from her late husband.)
3017. Amédée F. Rémond, Birmingham—New or improved metallic tubes.
3018. James White, East-street, Red Lion-square—Improvements in friction joints or fastenings.
3020. Claude A. Roux, Paris, and 16 Castle-street, Holborn—Improvements in printing warps of cut pile and similar fabrics.
3021. Hippolyte C. Vion, Paris, and 16 Castle-street, Holborn—Improvements in pistons and stuffing boxes of engines moved by water, steam, or gas.
3022. Alfred V. Newton, 63 Chancery-lane—Improvements in the manufacture of screws.—(Communication.)

Recorded December 30.

3026. Henri C. Camille de Ruolz, and Anselme de Fontenay, Paris—Improved metallic alloy
3028. Walter Mabon, Ardwick Iron Works, Manchester—Improvements in machines used for rivetting together metallic plates.
3030. John Milner, Stratford, Essex—Improvements in connecting the rails of railways.

Recorded December 31.

3034. Weston Tuxford, Boston—Improvements in portable thrashing machines, part of which improvements is also applicable to fixed thrashing machines.
3036. Richard Waygood, Newington Causeway—Improvements in portable forges.
3038. James Slater, Salford—Improvements in cocks, taps, or valves.
3040. Thomas Brown, Manchester, and Peter MacGregor, same place—Improvements in power-looms for weaving.
3042. Benjamin Hunt, Brighton—Improvements in obtaining and applying motive power.
3043. François A. Clerville, Paris, and 4 South-street, Finsbury—Improvement in the construction of fire-arms.

Recorded January 2, 1854.

2. Edwin D. Smith, 7 Hertford-street, May Fair—A mode of communication between the passengers, guards, and engineer of a railway train.
4. James Gowans, Edinburgh—Improvements in apparatus for heating and ventilating, and in baths and washing apparatus connected therewith, applicable to dwelling houses.
6. Peter A. Le Comte de Fontaine Moreau, 4 South-street, Finsbury, and Paris—Improvements in dyeing wool.—(Communication.)

Recorded January 3.

8. Henry L. Corlett, 106 Summer Hill, Dublin—Improvements in caoutchouc springs for locomotive engines and tenders, railway carriages and waggons.
10. David Kennedy, Reading, Pennsylvania, U.S.—Invention for the use of tanners, being certain compositions of matter to be used in the manufacture of leather.
12. Felix A. Testud de Beauregard, Paris—Improvements in drying cigars, and ligneous materials or other substances.
14. John Collins, 32 St. Ann-street, Liverpool—Improvements in the manufacture of vinegar.
16. Thomas Mann, Horseham, Sussex—Improved cinder shifting shovel.
18. John Dransfield and William Robinson, Oldham—Improvements in carding engines, for carding cotton, wool, and other fibrous substances.

Recorded January 4.

20. John Taylor, Miles Wrigley, and Samuel Greaves, Oldham—Improvements in carding engines for carding cotton, wool, and other fibrous substances.

Information as to any of these applications, and their progress, may be had on application to the Editor of this Journal.

DESIGNS FOR ARTICLES OF UTILITY.

Registered from 22d Dec., 1853, to 10th Jan., 1854.

Dec. 22d,	3542	H. Barlow and J. Kay, Manchester,—“Blind apparatus.”
	3543	C. Meinig, Leadenhall-street,—“Grindstone-frame.”
31st,	3544	G. W. Reynolds, Birmingham,—“Garter-fastener.”
1854.		
Jan. 2d,	3545	Holden and Nicholas, Birmingham,—“Shot-charger.”
	3546	W. Meyerstein, Friday-street,—“Sofa-bed.”
5th,	3547	H. Hill and R. Millard, Dunganon-street,—“Chair-arm.”
6th,	3548	Dent, Alford, & Co., Wood-street,—“Windsor-cravat.”
7th,	3549	J. D. Potter, Poultry,—“Parallel-rule.”
	3550	Hammond, Turner, & Son, Birmingham,—“Button.”
	3551	Hammond, Turner, & Son, Birmingham,—“Metal button.”
10th,	3552	Stock & Son, Birmingham,—“Water-closet.”

DESIGNS FOR ARTICLES OF UTILITY,

Provisionally Registered.

Nov. 14th,	544	A. N. Dare, Piccadilly,—“Collar.”
19th	545	G. S. S. Gower, Ipswich,—“Shirt-front.”
21st,	546	G. H. Wain, Liverpool,—“Tulley-block.”
	547	F. Clerk, Whitehall,—“Pipe-tube.”
22d,	548	C. Rowley, Birmingham,—“Button-shank.”
24th,	549	G. Sivers, Bingley,—“Sash-plane.”
29th,	550	J. Wren, Tottenham-court-road,—“Chair-bedstead.”
Dec. 7th,	551	R. P. Hopkins, Wimbourne,—“Lamp.”
8th,	552	T. Trotman, Camden-town,—“Child's-carriage.”
24th,	553	T. Trotman, Camden-town,—“Chairiot.”
1854.		
Jan. 7th,	554	J. Duffett, Bristol,—“Indicator.”

TO READERS AND CORRESPONDENTS.

COMPLETION OF THE 6TH VOLUME OF THE “PRACTICAL MECHANIC'S JOURNAL.”—Our next Part, No. 72, completes the 6th Volume of this Journal, when the set may be had from any bookseller, in cloth, lettered, price 14s. each, or the whole 72 Parts separately, for binding, to suit the purchaser. The set may also be had, handsomely bound in half-calf, and lettered, to form three double volumes, with the Plates bound separately, to correspond, price 31s. 6d. for each double volume and volume of Plates. Volume VI. will contain 27 quarto pages of Copperplate Engravings, and nearly 700 Engravings on Wood. S. P., Newark.—Messrs. Watkins and Hill, 5 Charing Cross, London.

A YOUNG MILLWRIGHT.—See “The Practical Draughtsman's Book of Industrial Design,” page 44.

STEAM-ENGINE FOR A LATHE.—An Oxford correspondent writes as follows:—“I am about to construct a small engine to drive my lathe; but before getting the castings, I wish to obtain advice as to the diameter of cylinder, and length of stroke, and weight of fly-wheel, necessary to drive a 6-inch centre self-acting lathe, in a satisfactory manner. The boiler to be a plain horizontal tubular one; single flue, and fire in centre. What will be the proper size, and what the most desirable working pressure? The engine is to be a high pressure one, with expansion gear.”

REFLECTING FOG BELLS.—The signature to this communication, at page 240, in our last number, ought to be THOMAS MEIKLE.

SCIENCE.—For lines with sharp curves, such a plan is obviously desirable. Nothing of importance has been done here, except the partial importation of the American “hogie,” or swivelling truck. See our plate in Part 35, Vol. III. We shall be glad to see our correspondent's suggestion.

J. S.—His engine strongly resembles the plans of Messrs. Yule, Davies, and others. All the novelty which we can detect is in the mode of setting up the pistons.

E. P., Rio de Janeiro.—His letter, requiring private information of interest and value only to himself, cost us 2s. We have forwarded the communication to the proper party.

J. M., Aberdeen.—This information amounts to nothing. Besides, it would be premature to publish until he possesses his legal security.

THE AGE WE LIVE IN.



It is universally admitted that definitions form some of the most difficult matters that the man of science or art has to deal with. And yet how often and often do we jump at and tenaciously hold on to them, heedless of things observable by the slightest attention, and which, if observed, must necessarily lead us to alter or modify the definitions to which we cling? No doubt, the true reason of this constant shifting of the very foundations of thought is the fact of the constant shifting of all circumstances pertaining to us, as that the true reason

of our grasping at definition is to be found in our unconscious endeavour to rest awhile in our steady but uncontrollable course along the stream of time.

If the attempt be thus vain with regard to what we have above called the very foundations of thought—the *a a*, *b b*, and *c c* with which we form the syllables of world-teaching—how much more so must it be when, as in our race onward to a goal or no goal, man's imagination strays aside into the wide universe, and fancies his great world of various labours floating onwards by him, and attempts to portray its actual status between its whence and whither?

It is thus that some individual first called the age we live in a mechanical age.

We cannot but suspect that the term originated with some one who, indignant at the darker follies of his neighbours, made his rod of castigation out of the gross antithesis of his habitual thought. We call it the gross antithesis, however, in the sense only of the least abstracted. But somehow or another, the general public mind appears to have adopted the low meaning conveyable by the expression, and to have thrust it, *volens volens*, upon the mechanic. Who is he? What is he? Oh, he is only a mechanic! One of those living hammers, or breathing chisels, that heat and heat, and hew and hew, until they effect any desired change of shape or figure in any material—one of those noisy or noiseless wheels set to work by the power of capital, and whose only virtue consists in the same monotonous and uniform motion all the long year round.

Not quite such a *thing*, we think.

If the age may truly be called mechanical, it must be so in a different sense from all this. What! are we to imply that our thinkers think mechanically? That, just as our fathers thought, so we are to think, and do think? That the "good old times" have left to us nothing but the best of things, and modes, and that all our efforts to compete with them must be puerile? Are we to believe that all the worthies of the world have already lived and died, and that no more can come? Are we so self-opinionated that we cannot trace something better than ourselves in the youth springing up around us—in the neighbour by our side? There are moments, indeed, when the dullest among us cannot be otherwise than startled with some indications of the present age being far otherwise than mechanical. On all sides around us we behold a continuing argument to this end. Let us look only at a particular instance when it first passes under our observation, and we see some peculiar constitutional exercise of an inventive mind that is very different from what is universally admitted to be mechanical, in the low sense of the term. *Ab uno disce omnes*, and we are enforced to deduce the same conclusion, after observing the legion of new inventions of the present day, until at length we find ourselves compelled to discover all our preconceived notions to be turning—nay, to have turned—a very sharp corner indeed, inducing a belief that, so far from the present being a mechanical age (always in the sense already disparagingly noticed), it is the most nobly spiritual age that the world has witnessed. We do not call it

spiritual (as perhaps we might) in there being more aiming at spiritual things through the means exercised by the best Christians; but we call it the most spiritual, inasmuch as we consider that in no age of the world has man's mind been endowed with so much power for good or for evil as is the present hour.

By thus defining our position, we are not calling it a better, we are also not calling it a worse, age. This has been the rock at which both the wise and the unwise have stumbled. People have stereotyped in their brains ideas of good and bad attaching to progress. This is not necessary. We do not, however, mean to say that, other things being equal, if what we call good holds larger sway than what we call evil, that we are not progressing; but we mean to say, that without any reason at all in the matter, we are not, philosophically, justified in fellow-yoking with progress a result which possibly may hold many different complexions from the idiosyncratic points of view with which it is looked at.

We cannot see what we call Power. It is not a tangible entity. We know it only by observing the result of its use. We know it exists in the same mind, because we see it exercised, in some cases, in a pleasing, and others in a manner abhorrent to us. But look where we will, at all hours of the day and night, at all seasons of the year, in every age of life, there it stands forth before us in some manifestation or another, and no obscurity can conceal it from us.

It is of paramount importance that our readers especially should hesitate to believe and to act upon the belief that this is a mechanical age only. It is of equal importance that they who may have too readily accepted this character, of what we may, with no impropriety, call their *own world*, should abandon the idea at once, for it clips the wings of the imagination, (which is only another name for power, in one sense,) and cramps high effort most effectually. We have had this shackle about us already too long. It gives us a faith different somewhat from that which the great reasoning herald of modern inductive science would have endowed us with. Indeed, it not only does not enable us mentally to realize "all things possible," but makes us not fear to tread in paths well known to angels as to men. Let us believe rather in "the effecting of all things possible"—that there is no one thing within the domain of the possible which is out of man's attainment. Let us no longer nickname this magnificent *locale* of wondrous appearances among which we ourselves are found, but ascribe to it due honour. Let us do this, not by throwing an idle word to the winds, but rather in demonstrating our own view of the subject, by the full and free use of our own power, each, from his own particular centre, radiating forth all that is not opposed to his conscience.

We would ask our young readers particularly to reflect how times and seasons come and go; how circumstances surrounding them are ever, ever shifting; how, as hour after hour passes, each one, by constantly enlarging the boundaries of his knowledge, is really living in a completely new world.

Our pages, month after month filled with descriptions of new inventions of all kinds, really prove that, although our countrymen appear to believe the age to be a mechanical one, they act in complete disbelief of the notion. And if our readers were behind the scenes with us, still greater proofs would be daily observable. Why then libel the time we live in, and libel it too to our own hurt? What's in a name? you, strange reader, may say. By asking this question, you show that all we could say must necessarily be lost upon you. We expect no such question from any of our readers—from any pure mechanic—and for this simple reason, that his school has been nature. He knows that his tools are simply modes of using her powers—that they are in their most efficient state when he most correctly observes; and that with them, sharpened to all use, his strong arm will raise up a monument, in the coming time, grander, because only mightier, than that which his coadjutors, in the past, have erected in our own, by having bestowed upon it the distinguished, though erroneous, sobriquet of "The Mechanical Age."

LUTTGENS' DIFFERENTIAL-ACTION GOVERNOR FOR STEAM-ENGINES.

In this governing apparatus, which is the invention of Mr. H. A. Luttgens of New York, the expansion or cut-off valve is actuated by an eccentric, which is made to assume different degrees of eccentricity, in obedience to the action of the governor. Considerable ingenuity is displayed in the details of the apparatus, which we engrave in two views. Fig. 1 is an elevation of the governor, together with the main crank of the engine and a portion of the framing; and fig. 2 is a vertical section, on an enlarged scale, of the mechanism for communicating the governing

Fig. 1.

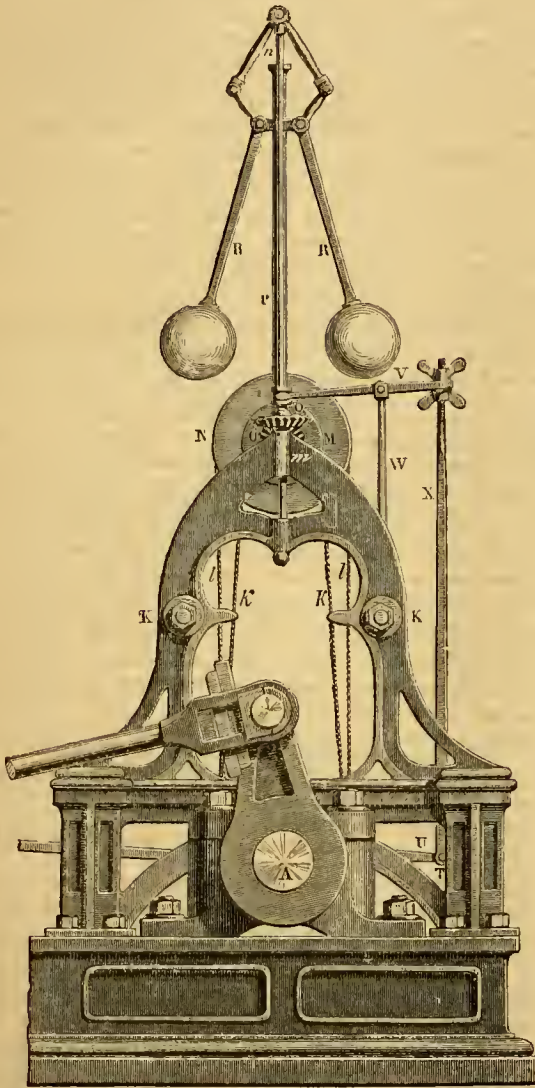

action to the eccentric which works the cut-off valve, these details being carried by the main shaft.

The main shaft, *a*, of the engine, has keyed upon it a pulley, *b*, the belt, *h*, of which actuates a pulley, *m*, on a short transverse shaft, immediately above and parallel to the main shaft. This upper transverse shaft carries a bevil wheel, *o*, in gear with a bevil wheel on the vertical spindle, *r*, of an ordinary ball governor, *n*. The spindle, *r*, is supported in footstep and upper bearings, *m*, in the engine-framing, *k*, which is also provided with bearings, for the support of the upper transverse shaft. The same shaft has also keyed upon it a pulley, *x*, of larger diameter than the pulley, *m*. From the pulley, *x*, a belt descends to a pulley, *v*, fig. 2, carried loosely, by the enlarged boss of a pulley, *d*, loose upon the main shaft, *a*. A disc, *f*, is bolted to the boss of the pulley, *d*; and the pulley, *v*, is held between the disc and outer part of the pulley, and is provided with a friction-ring, *h*, on each side, the rings being

pressed outwards by helical springs, *t*, so as to hold the pulley, *v*, with a determined pressure, between the pulley, *d*, and disc, *f*. The pulley, *d*, and disc, *f*, are prevented from moving longitudinally on the main shaft by means of retaining-collars, *g*. The disc, *f*, is formed with a rim, *e*, having internal teeth, in gear with which is a small pinion, *j*, fast on a short spindle, *i*, carried in hearings, *u*, fast upon the main shaft. The opposite end of the spindle, *i*, carries a small bevil wheel, *j'*, in gear with a similar bevil wheel, *s*, on the inner end of a screw spindle, *c*, lying in a radial direction with reference to the main shaft, and at right angles to the spindle, *i*, which is parallel to the former. The outer end of the screw-spindle is held by a centering-screw, passed through a small bracket upon the pulley, *b*. The screw-spindle, *c*, works in a nut, *t*, fast upon the eccentric, *c*. This eccentric is formed with an elongated opening, so that it can be set with different degrees of eccentricity with reference to the main shaft. It is held by V-slides, *b*, working in guides, *a*, cast upon the face of the pulley, *b*.

Fig. 2.

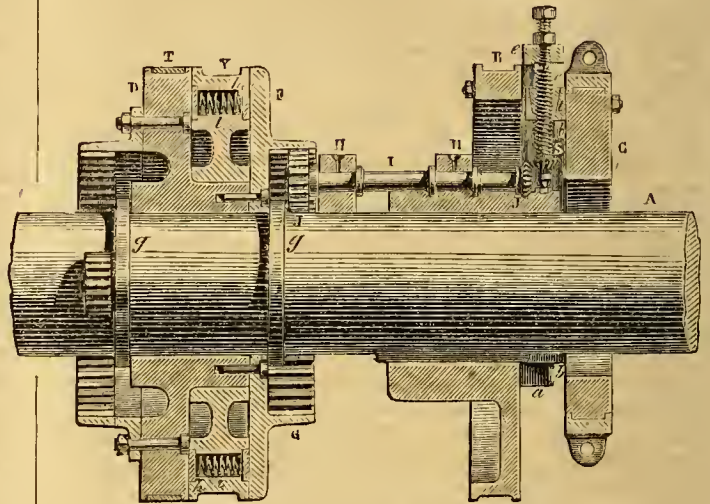

The action of the governor balls is communicated by two slender rods, *z*, to a grooved collar, *q*, loose upon the spindle, *r*. This collar is embraced by the forked end of a lever, *v*, carried by a support, *w*, rising from the framing. To the outer end of the lever, *v*, is adjusted the rod, *x*, passing down to a lower lever, *u*, which is connected to a steel friction belt, *t*, upon the pulley, *d*, so that the action of the governor increases or diminishes the friction, as the case may be. The apparatus is so adjusted that, when the shaft, *a*, revolves at its determined rate, the tendency of the pulley, *v*, due to the proportions of the several pulleys, *b*, *m*, and *x*, to drive round the pulley, *d*, at a quicker rate than that at which the shaft, *a*, is revolving, is just balanced by the action of the retarding friction brake, *t*. If, from any cause, the velocity of the engine increases, the action of the governor balls will tighten the brake, *t*, so as to retard the velocity of the pulley, *d*, and its internally-toothed wheel, *e*. As, however, the spindle, *i*, with its pinion, *j*, is carried round with the shaft, *a*, it will be caused to turn on its axis to an extent proportionate to the retardation of the pulley, *d*. This action, by means of the bevil wheels, *j'*, *s*, and screw spindle, *c*, will so act on the eccentric, *c*, as to alter its eccentricity, and thereby reduce the supply of steam.

If, on the other hand, the engine goes at a slower rate, the falling of the governor balls will relax the brake, *t*; the pulley, *v*, will then act on the pulley, *d*, and wheel, *e*, so as to make these revolve at a quicker rate than the main shaft. The spindle, *i*, will, in consequence, be turned as before, but in the reverse direction, and the necessary adjustment of the eccentric, *c*, will be thereby effected.

In an ordinary ball governor, if the rate varies, the balls rise or fall, and shut or open the throttle valve. The engine is then brought back to its proper rate; but, as a consequence, the balls return to their first position, and the throttle valve is necessarily, also, brought back to its original position, and the benefit is thus only momentary.

This defect does not exist in Mr. Luttgen's arrangement, since the adjusting of the eccentric, for a variation in the rate, does not cease until the balls recover their proper position; and a reverse action cannot take place unless the balls go beyond that position in the opposite direction.

THE ROYAL INSTITUTION.



THE name of this establishment has been, and is, upon many tongues; but we have found comparatively very few persons, out of its list of members, who are acquainted with its actual position among the scientific institutions of the land, and scarcely one informed with regard to its origin and history; indeed we are not aware that any printed document exists in which information on these points is to be found. We propose, therefore, to devote a few lines to the subject, so that at least our own readers may not remain in ignorance—or what is worse, misinformed—with regard to what we may justly call the most brilliant scientific association in the British Empire.

The names of Humphrey Davy and Michael Faraday—so honourably known in all the world wherever any gleam of science has penetrated—which have been immediately and successively connected with the institution, almost from its foundation, have impressed upon it somewhat of their own fame; and hence the general public, who hear little and know less, commonly regard it with an indefinite sense of something awfully profound, dryly scientific, intensely blue. But its intention is this wise.

Many years ago—still not quite out of the memory of the present generation—there sat together over their afternoon's refreshment two gentlemen. The one was all science; the other all the lover of it. The conversation naturally flowed into the channel most agreeable to both. The former detailed the new tidings of the day in all departments of study, and expatiated, in a strain, eloquent from its very character, upon the prospective general benefits which would, in his mind's eye, necessarily result from them. Visionary, in some degree, as the ideas uttered forth were to the other of the party, a brighter beam shot over his benevolent-looking face as he silently listened. The number and labours of the then existing societies in London, established for the purpose of disseminating knowledge, were discussed, and the germ—though then, as yet, however, sufficiently indistinct—of founding another was born.

When this conversation took place, a youth of twenty-one was in a country town, far away from the metropolis, revising an epic poem written by him at twelve, or, after analysing some compound substance, was writing to a friend, "philosophy, chemistry, and medicine are my profession,"* becoming unconsciously a devotee to his "harsh mistress," science, and who not long afterwards resolved to make no profit of anything connected "with her."† This was the future Davy. There was also at the same time a little boy of some seven or eight years of age, destined in due, or rather undue, time to be apprenticed to a bookseller, and to turn from the stores at his command to the great book of nature, already beginning to be conscious that he could accurately see, and handle, and understand things and appearances around him, although he did not then know that this was scientific observation, or that the facts he perceived were known to others by the high-sounding name of phenomena. The two fine old English gentlemen as little dreamt that in that child would be developed, by means of the realization of their present desire, the latent genius of Faraday. Count Rumford bade his friend, Sir Joseph Banks, "Good night," and going down the steps of the great centre house, on the west side of Leicester Square, lately used as the Western Literary Institution, walked pensively homewards. They thus separated for the evening; and each in his little coterie endeavoured to bring about an assemblage of friends of similarly constituted minds and dispositions. The first meetings to talk over the idea were held at the house of the distinguished traveller and naturalist, and the ingenious and eccentric Count continued to promote it in every way in his power. The number of congenial minds multiplied at every successive meeting, while, at every successive meeting, arguments of the substance of new, interesting, and important facts, enforced upon the conviction of all, not that a new society had to be, but that a new institution had, in fact, been founded.

The Royal Society beginning then to be devoted mainly to the physico-mathematical science, had its royal charter; why should not "We?" The fight for this traditional English vantage ground was not likely—with the doughty hearts around, and conducted by their enthusiastic leaders—to be long lasting. The easy old monarch's ear was soon reached; some dim hope of shedding brighter lustre on his reign had its

legitimate influence, and the usual authorities received instructions to prepare the draft of the longed-for charter of incorporation, which "will make our institution no longer dependent upon our subscriptions or our wills, but will make it a living, self-subsisting thing, immortal in the land."

"Ah! this is the charter for the Royal Institution," said George the Third, as his favourite minister put a finely illuminated copy into his hand; "good society, good society—wanted, wanted—glad of it, glad of it." The heads were carefully explained to the king, who, to his honour, listened with as much attention as he was capable of, and directed the formal instrument to be forthwith prepared. This was not long before the 13th of January, in the 40th year of his reign; and that day stands in the Royal Testimonium—"Witness Ourselves at Westminster"—as the day on which the incorporation of the members originated.

This charter recites the fact of "several of our loving subjects being desirous of forming a public institution for diffusing knowledge and facilitating the general introduction of useful mechanical inventions and improvements, and for teaching, by courses of philosophical lectures and experiments, the application of science to the common purposes of life," and having subscribed considerable sums of money for that purpose, had "humbly besought" to have the charter granted. Whereupon His Royal Majesty, "being desirous to promote every useful improvement in arts and manufactures, for the increase of the industry and happiness of all our loving subjects, &c., &c., our right trusty and well-beloved cousins, George, earl of Winchelsea and Nottingham, George, earl of Morton, George, earl of Egremont, and Frederick, earl of Besborough, our right trusty and well-beloved counsellors, Thomas Pelbam and Sir Joseph Banks, our trusty and well-beloved Benjamin, count of Rumford, of the Holy Roman Empire, Sir John Cox Hipplesley, Richard Clark, Esq., chamberlain of our city of London, and Rd. Joseph Sullivan, Esq., and such others," &c., were declared to be "one body politic and corporate, by the name of 'The Proprietors of the Royal Institution of Great Britain,' and by the same name to have perpetual succession," &c., &c., with power to possess property to the amount of £2,000 yearly value, and to have a common seal. The direction and conduct of the institution were declared to be by a committee of managers, a treasurer, and a secretary, to be elected by, and from among, the proprietors; the Earl of Besborough, Count Rumford, and Mr. Clark, holding the places of chief honour in the first nomination of managers, viz., for three years, while the nomination of others above-named was limited to one year from the 1st of May, 1799. The Earl of Winchelsea was named the first *president*. The Earls of Morton and Egremont, and Sir Joseph Banks, the first *vice-presidents*; Thomas Bernard, Esq., the first *treasurer*; and Samuel Glasse, Doctor in Divinity, the first *secretary*. A committee of *visitors*, also to be elected from among the proprietors, is instituted. The managers, or any five or more of them, with the consent of the visitors, or any, &c., are empowered to make *bye-laws* and appoint officers. The mode of electing the managers, president, treasurer, and secretary, is then pointed out; accounts, &c., are required to be kept, examined, and reported upon, with other customary provisions under somewhat similar circumstances.

For upwards of ten years the institution went on flourishing, the hopes of all the "proprietors" gradually rising; some with the warm, generous, and genial glow whence everything of mundane good has originally grandly sprung; others with a glow, indeed, but of calibre of another kind. Suffice it to say, that the element of private property in the institution was just such an element as it could very well do without. It is the glory of science, that in all times she has scrupulously regarded the behest, "Touch not the unclean thing." Some may judge her selfish in this matter, that money distracts her attention from her own little pet private pleasure, and therefore she desires to have nothing to do with it, to be out of temptation's way. But a sentiment more honourable than this abounded more and more, as gradually the wish grew into the way of completely and for ever annihilating all suspicion of the hope of pecuniary benefit attaching to all parties connected with the Royal Institution. This was effected by an act of parliament, which was passed in 1810, "for enlarging the powers granted by his Majesty to the Royal Institution of Great Britain, and for extending and more effectually promoting the objects thereof."

This act recites the charter, and the facts of the proprietors having then purchased a house, and formed a mineral collection, library, and laboratory; and that, at a general meeting of the proprietors, it was unanimously determined, that measures should be taken to form on its basis a public national and permanent establishment, devoted to the cultivation of practical science, and to the promotion of every improvement in agriculture, manufactures, and the arts; and that it was also determined, that all the saleable and hereditary rights of the proprietors should be done away with. After further reciting various other improve-

* Paris's Life of Davy, p. 43.

† In a letter to J. G. Children.

ments and alterations, rendered expedient or necessary in consequence of the fundamental change in the constitution mentioned above, this special law enacts that the objects of the institution shall be extended, and applied to the prosecution of chemical science, by experiments and lectures for improving arts and manufactures, to discovering the uses of the mineral and other natural productions of this country, and to the diffusion and extension of useful knowledge in general; and that the name should be "The Members of the Royal Institution of Great Britain."

By this law no member can have more than a life interest, and provisions are made for compensating the loss of proprietary rights. The election of managers and visitors is declared to be by ballot, from among the members subject to the bye-laws; and regulations are made as to the making, adhering, or repealing of any bye-law. Other incidental clauses are embodied in the act, which, short as it is, has hitherto satisfactorily answered the ends of its promoters.

It is thus seen that the chief objects of the institution are, as expressed in the prospectus—

1. To promote Scientific and Literary Research;
2. To teach the Principles of Inductive and Experimental Science;
3. To Exhibit the Application of these Principles to the various Arts of Life; and
4. To afford Opportunities for Study.

By the bye-laws the institution is governed by a president, fifteen managers, fifteen visitors, a treasurer, and a secretary, chosen annually from among the members.

The bye-laws, moreover, regulate the admission of members, the election of the officers, the duties of the several members of the governing body, the forms of and proceedings at meetings, the disposition of the property of the institution, the custody of the common seal and title deeds, and the internal economy of the house. They also legislate as to professors, lecturers, and lectures, and provide for the increase of the library and other collections, and for the care of the laboratory and its extensive apparatus, which, in many examples, stands unapproached.

Any person desirous of being admitted a member must be first proposed at a general monthly meeting, and recommended in a printed form, which must be signed by four members at least. This form states the candidate's desire to be a member, also his knowledge or love of science, adding that the same is certified from their personal acquaintance with him or with his works. This paper is then exposed in the house until the next monthly meeting, when the ballot takes place; the month's delay being, however, not required in the case of peers, peers' sons, and privy councillors. The ballot being in favour of admission, the candidate pays his entrance fee of five guineas, and enters into an obligation to pay a like sum annually, as long as he remains a member; or he pays about sixty pounds as a composition for all payments, and becomes a life member. A further payment is, previous to admission, required to be made to the library fund. These fees and subscriptions entitle the member to all the advantages of the institution: one of the principal of which is the right of free admission for himself, and two nominees above fifteen years of age, to the celebrated Friday evening meetings. This is the ordinary subscription; as a matter of course, different grades of benefit attach to different amounts of subscription, but we cannot here enter into the details. Ladies may be admitted as members; and the institution, at the present moment, rejoices in the names of many, at the head of whom is that of our Queen, whose autograph as the patron may be inspected in the Register Book of members.

Honorary members have the usual privileges of admission, and the usual deprivations of a vote and eligibility to office. Among these honorary members are numbered some of the most brilliant in modern times—Cuvier, De Saussure, Klaproth, Leopold Von Buch, Humboldt, Berthollet, Gay-Lussac, Biot, Arago, Oersted, Berzelius, Raumer, Silliman, Liebig, &c.

The Emperor Nicholas himself, who seems now to be striving to throw all science, except fortification and gunnery, to the winds, is enrolled as such an honorary member; but we shall see, by-and-by, how, for some unexplained reason, he refused, when here in 1843, to sign his imperial autograph in the Members' Book. This is a curious fact to reflect upon at the present moment.

All members have a right of admission to all parts of the institution; to all the lectures and public experiments; to the repositories, library, reading-rooms, collections, and laboratories; as well as of sending any substances likely to be useful in arts or manufactures, to be analysed and reported upon.

The Library, of nearly 27,000 volumes, includes the best editions of the Greek and Latin classics and the fathers of the Church,—English county histories,—works of science and literature, of art and antiquarian research,—the transactions of the principal British and Foreign academics and

scientific institutions, as well as an extensive collection of historical and miscellaneous tracts.

Among the principal of the more precious articles—the MSS.—here collected, are the MS. Note Books of Sir Humphrey Davy, the MSS. of his papers printed in the Philosophical Transactions, some miscellaneous papers of Lord Stanhope, and fifty-six volumes of letters, &c., respecting the American War, principally regarding the movement of the British troops, and Dr. Boyce's musical MSS.

It is not unworthy of remark, as showing the animus which prevails among the members in general, that this large collection of books has been made by free gift of individuals composing the body, or interested in the welfare of the institution.

The first edition of a catalogue was published in 1809, a second edition in 1821. A new classified edition is now in course of construction, under the careful superintendence of Benjamin Vincent, Esq., and his son, Mr. Charles W. Vincent.

In a Reading-room for study will be found many series of English, French, German, and Italian scientific memoirs and journals, and a great number of works connected with medicine and the mathematical sciences.

A Newspaper-room contains the principal journals, magazines, and reviews, in the English, French, and German languages; and a circulating library is subscribed to, in order to afford the members an opportunity of seeing the newest books as soon as published.

The Museum contains mineral specimens, many of which are named, and also other collections. The chief object of this museum is to furnish illustrations for the regular lectures, and the Friday evening discourses. Among some of the more interesting, although perhaps not estimated by all as the principal objects in this collection, may be mentioned the following:—One of the first Davy lamps, and one of the first diamonds converted into charcoal by the battery, and some other of these first and first-rate things. An enormous mass of Amethyst Rock, weighing 131 lbs.; models of Crystals by M. Haüy, who investigated the subject of their structure so interestingly; Queen Elizabeth's Pocket Watch; Busts of George III., John Fuller of Rose Hill, a very liberal benefactor to the institution, Faraday, &c.; and portraits in oil, drawing, or prints of the Earl of Winchelsea, the first president, Count Rumford (painted, by-the-by, by his daughter), John Fuller, Sir Humphrey Davy, Faraday, Earl Spenser, the curious Sir John Soane, and those of D. Moore and Dr. Paris, the present president of the College of Physicians, and the biographer of Davy. An excellent sketch of the venerable chemist, Brande, must not be omitted, but we cannot mention all. While more immediately connected with the celebrated laboratory are many scientific machines and instruments, which have been influential in aiding those discoveries in science which have distinguished the Royal Institution, and upon which we shall say something in another paper.

THE LAW OF PATENTS FOR INVENTIONS IN THE EMPIRE OF AUSTRIA.

This law has been recently remodelled by an imperial decree, dated the 15th August, 1852, which established the following regulations throughout the empire. Patents are not allowed for alimentary preparations, beverages, or medicines, nor for discoveries, inventions, or improvements which are contrary to public health, public welfare, morality, or the interest of the state. With this exception, patents are granted for every new discovery, invention, or improvement, having for its object (a) a new industrial product, (b) a new means of producing, or (c) a new method of producing. By discovery, is meant the refining of something once known, but subsequently lost. Invention signifies the production of something new, either by new or old successes, or of something already known by a new process. Improvement signifies the application of a contrivance, arrangement, or process, to an object already known, whether patented or not, whereby, in the object itself, or in the mode of production, a more favourable result or some kind of economy is obtained.

A discovery, invention, or improvement, is deemed new when, up to the moment the patent was applied for, the same had not been put into operation, or been made public in the empire.

Foreigners, as well as Austrian subjects, may be patentees; but with regard to inventions made by foreigners not resident in Austria, patents are only granted when a patent has been obtained in the country where they were made, and then only to the original patentee, or his assignee.

A mere unapplied scientific principle is not patentable; but every new application of such a principle may be patented, if constituting a new industrial product, or a new process of manufacture.

Two or more inventions cannot be included in a single patent, unless they refer to the same subject matter, as essential parts of it.

The petition for a patent may be made either by the inventor, or by his legal attorney, and must comprise the full name, profession, and domicile of the inventor, or of his attorney; also, the exact title of the invention, and the number of years for which it is desired the patent should last. The maximum duration of a patent is fifteen years, which length of time cannot be exceeded, except by special imperial authority.

When the petition is lodged, it must be accompanied by the proper amount of patent tax, or by the voucher, showing that the tax has been paid. There are no other payments exacted, even when a previous examination has been made for public consideration.

The amount of government tax is thus paid:—For the first five years, 20 florins (£2) a year; sixth year, 30 florins; seventh year, 35 florins; eighth year, 40 florins; ninth year, 45 florins; tenth year, 50 florins; eleventh year, 60 florins; twelfth year, 70 florins; thirteenth year, 80 florins; fourteenth year, 90 florins; fifteenth year, 100 florins; or for the entire fifteen years, 700 florins (£70).

Previous to, or at the time of lodging the petition, the tax must be paid for the entire number of years for which the patent is applied for.

The description (specification) accompanying the petition must be in the German language, or in the language of the province in which the petition is presented; it must contain a full and minute explanation of the invention, and must be so clear that any professional person may carry it into effect, without being obliged to supply anything; the novel part, that which forms the essence of the invention, must be minutely indicated; nothing must be concealed, either as to the materials or the process; the materials must not be represented as more expensive than they really are, nor must any peculiar method or contrivance, necessary to the success of the operation, be kept back; if drawings, samples, or models, are required for the full comprehension of the description, they must be supplied.

A patentee is entitled to establish workshops or factories, to employ the workpeople he may find requisite to carry out the object of the patent to its fullest extent, and consequently to form establishments, stores, and warehouses for the manufactory, within the entire empire. He may sell and dispose of the proceeds, and license others to use his invention, to take partners, and to dispose of his patent right in any way whatsoever.

A patent for an improvement is strictly confined to the particular improvement, and confers no right upon a previously patented invention, or any publicly practised process upon which it may be an improvement. The patentee of an improvement is effectually protected against the original patentee, who cannot make use of the later invention without license.

When the original term of a patent is less than fifteen years, the patentee may apply to have it prolonged for the full period of fifteen years. He must make application before the term originally limited has expired, and he must pay the entire tax for the term of prolongation.

A patent will be cancelled on proof that the legal requisites for a patent do not exist, or that the description does not fulfil the prescribed conditions, or that the invention is not new, or being an importation from abroad; that the patentee is not the real owner of the foreign patent, or that the object of the patent is contrary to law, as to the health or morality of the public, or the interest of the state.

A patent will expire not only by efflux of the term, but also in case the patentee should fail to bring his discovery into operation within a year from the date of the patent, or in case he should entirely suspend working the same for the space of two years.

A patent, on being granted, is enrolled in a register, kept at the Ministry of Commerce and Industry, which register may be inspected by any one. Copies of patents may also be taken.

Patents may be transferred, either entirely or in part, at the option of the patentee or his assignee.

Persons will be deemed guilty of infringing a patent who import from abroad objects, counterfeiting or imitating those made under the patent, with the view of selling the same.

The remaining sections of the decree have reference to the mode of obtaining patents, or to official proceedings for their publication, registry, &c., or to the punishment of persons infringing them, and need not be set forth here.

This consists of a coupling-box, A, connecting two separate portions of the main shaft of a steam-engine, or other prime mover. The end of the shaft, B, which is the one in immediate connection with the prime mover, has one or more helical threads cut upon it, and the coupling-box, A, is at that end formed with an internal thread to correspond. The end of the shaft, C, which conveys the power to the machinery to be driven, is formed with longitudinal feathers working in grooves in the corresponding end of the coupling-box, A. The two shafts abut against each other, and are incapable of longitudinal movement. The coupling-box, A, is capable of traversing longitudinally upon the shaft, C, whilst it can only alter its position upon the shaft, B, by a rotatory combined with a longitudinal motion. The coupling-box is formed externally with two collars, constituting a retaining groove for the two points of the forked arm, D, of a lever connected with the throttle valve, or other regulating mechanism of the prime mover. Between the coupling-box, A, and a disc, E, abutting against a collar on the shaft, B, is an india-rubber cylinder, F, arranged like the bearing springs adopted by Mr. Coleman for railway purposes, and answering as an elastic connection, adjustable by screws in the disc, E.

As here represented, the apparatus is intended for shafts always revolving in one direction, and its action is as follows:—On starting the engine, the shaft, B, turning in the direction of the arrow, will tend, by the action of the screw, to force the coupling-box, A, against the spring, F, at the same time opening the throttle valve by means of the lever, D.

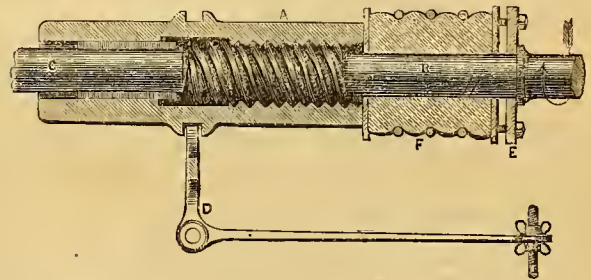

More steam will, in consequence, be gradually admitted to the engine, and the coupling-box will be driven more and more against the spring, until the increasing reactionary resistance of the latter balances the resistance to be overcome by the shaft, C, in turning. The longitudinal motion of the coupling-box will then cease, and the two shafts, B, C, will revolve as if connected by an ordinary coupling-box. The apparatus should be so arranged that, when the spring is in its most elongated state, the throttle valve may be just so much open as to allow sufficient steam to pass to overcome the friction of the engine itself.

If, from any cause, the load should increase, the longitudinal movement of the coupling-box, and consequent further opening of the throttle valve, will be the immediate result, the spring being still further compressed. On the other hand, if the load becomes less, the reactionary force of the spring will cause the coupling-box to traverse back upon the engine shaft, B, thereby partially closing the throttle valve.

For a shaft which is required to revolve in both directions, the coupling-box must be longer, and provided with springs acting in both directions, whilst the mechanism for actuating the throttle valve must be contrived to produce the same effect to whichever side of a central point the coupling-box is traversed. Instead of arranging the spring, as we have shown it, it may be applied to the lever, D, and it may be formed in various ways.

The spring being obviously a measure of the load, may be connected with an index, and thus form a dynamometrical indicator; it will, however, be necessary to take note of the number of revolutions in a given time, so as to form a true estimate of the power. It is easy to conceive a mechanical arrangement, in which counting gear may be so combined with the index of the spring, as at all times to indicate the momentary absolute power exerted.

This governor is particularly applicable to a screw propeller with swivelling blades, the action of the coupling-box being made to alter the inclination of the blades, and that instantaneously, on any change taking place in the resistance.

The spring coupling might also be beneficially applied to long ranges of shafting, as it would tend to soften the effects of sudden variations in the power or resistance transmitted.

Likewise, by dispensing with the spring, F, and converting the lever, D, into a simple hand lever for moving the coupling-box back or forward, a convenient means is afforded of setting round one part of a shaft in reference to another.

HUNT'S GOVERNOR FOR PRIME MOVERS AND SCREW PROPELLERS, AND SPRING COUPLING FOR SHAFTING.

The governor represented in the accompanying engraving recommends itself by its simplicity, and its direct mode of action. The power of the prime mover is transmitted through the piece, which constitutes its

WYMER'S SYSTEM OF BOAT GEAR FOR SHIPS.

The screw steam-ship *Chanticleer*, built by Messrs. Denny of Dumbarton, has lately been fitted with the boat-hoisting apparatus represented in our engraving. It is the invention of Mr. F. W. Wymer, of Newcastle-upon-Tyne. The boat, *A*, is hoisted up to davits, *B*, which are contrived to turn over inboard with the boat. For this purpose, each davit, *B*, is keyed into a socket formed radially in a large worm wheel, *C*, fast upon a shaft carried in iron brackets, *D*, fitted upon the top of the bulwark, *E*, of the vessel. The worm wheel is worked by a worm, *F*,

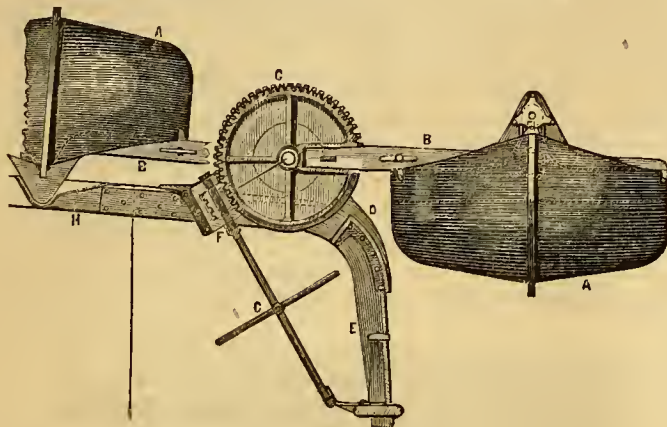

the spindle of which passes down at an angle convenient for the application of manual force to cross handles, *O*, fixed upon it. The davits are made to stretch across the boat, embracing its opposite gunwales by means of suitable projections. When the boat is to be raised, it is brought immediately below the davits, which stretch out horizontally from the ship's side, and is hoisted up to them by means of tackles in the usual way, sheaves for that purpose being fitted to the davits immediately over the centre line of the boat. Manual force is then applied to the worm handle, *O*, and the davits are made to turn through half a circle, carrying and turning over the boat at the same time, the whole finally resting upon the poop deck, *U*, round-house, or other support provided for it within the vessel. The cross handle and spindle, *O*, can be removed from the worm, so as to be put out of the way when not in use.

SMALL DIAMETER STEAM BOILER.

HOLCROFT AND HOYLE, ENGINEERS, MANCHESTER.

(Illustrated by Plates 144 and 145.)

The daily increasing use of high pressure steam, and the great economy of fuel gained by its judicious application, seem to point to a day not very far distant when its adoption shall become general; while, at the same time, the many fearful accidents which have attended its generation with old, miscalculated, or improperly constructed apparatus, call loudly for some particular modification of boiler, which shall render its use perfectly compatible with safety, and remove all feeling of risk or danger from the minds of those disposed to avail themselves of the advantages which it offers.

For this purpose, a boiler is required which shall possess increased strength, if possible, without additional expenditure of material, and which, while it combines the several advantages of the various existing modifications, shall be free from their drawbacks and defects. With this end in view, and to meet these requirements, the triple boiler, which we now illustrate, has been designed.

Fig. 1, on our Plate 144, is a transverse vertical section of the boiler; fig. 2 is an end elevation, looking on the fire and smoke-box doors. Fig. 3, on Plate 145, is a vertical longitudinal section, taken through the fire-box; and fig. 4 is a horizontal section, taken through the two lower boilers and the fire-box. The boiler consists of three distinct steam generators, *A*, *B*, *C*, triangularly disposed and supported in brickwork, *D*, *E*, at each end, and by two longitudinal walls, *F*, on each side of the ash-pit. The boilers communicate with each other by the pipes, *U*, which descend beneath the ash-pit; and the feed-pipe, *I*, provided with a stop-cock, *J*, is joined to them at their lowest point. The boilers are also blown off by this pipe, a stop-cock being provided for this purpose at the front. The lower boilers, *B*, *C*, are furnished with steam domes, *K*, and these communicate with the upper and central boiler, *A*, by means of the large horizontal pipes, *L*. In this manner the water in

all three boilers is maintained at the same level, and as the central boiler, *A*, has always a less quantity of water in it than the other two, it serves as a large steam chamber, whence the steam is conveyed by the steam-pipe, *M*, and on which is fitted the safety-valve, *N*. A pressure gauge, *O*, communicates with the boiler, *A*, in front, where are likewise three level gauges, *P*, communicating with each of the boilers. The fire-box, *G*, is immediately beneath the central boiler, *A*, and between the side boilers, *B* and *C*, which reach down to the grate bars, *Q*, in front, so that the direct action of the fire expands itself entirely upon the surfaces of the boilers, whilst the exposed surface is formed of a single plate in each boiler, thus avoiding the uncertainty and risk always attending rivet seams and unequal plates exposed to the direct action of the fire. The flames and gases pass to the back of the fire-box, and are there separated into two currents in the flue spaces, *R*, which admit them to the back of the side boilers, *B*, *C*. These boilers are provided with flue tubes, *S*, through which the flames and gases pass to the front smoke-boxes, *T*, whence they descend by the flues, *V*, to a single flue underground, communicating with the chimney. The smoke-boxes, *T*, are provided with doors, *W*, which greatly facilitate the cleaning out of the tubes. Access is also obtained through these doors to manholes in the front tube plates, by which the interior of the boilers are cleaned. A couple of doors are also provided at *X*, for cleaning out the back flue spaces, *R*.

The injurious action of sediment upon the bottom of the central boiler, *A*, which is entirely exposed to the direct action of the fire beneath, is prevented by the interposition of a sediment collector, *Y*. This consists of a false bottom of thin plate-iron, corresponding in shape to the bottom of the boiler, and supported at about three inches from the latter, whilst its edges reach to about five inches from the water-level above. The ebullition of the water on the bottom of the boiler itself prevents the settling down of the sediment, whilst the water inside the collector, being tranquil, encourages its deposition within it. A blow-off pipe (not shown in the engraving) communicates with the sediment collector, for the purpose of clearing it periodically.

The patentees lay fair claims to the following especial advantages, as embodied in this boiler:—The great strength due to the employment of a greatly reduced diameter. A boiler 4 feet in diameter, made of $\frac{5}{16}$ inch plates, and working at a pressure of 75 lbs. to the square inch, is subjected to no greater strain than a boiler 7 feet in diameter, made of $\frac{1}{8}$ inch plates, and working at a pressure of 60 lbs. A second advantage is economy in space—a sixty-horse boiler taking up a space of only 12 feet by 13 feet 6 inches, whilst a much larger fire space is provided than can be obtained when the fire-box is placed inside the boiler, and a very large surface is exposed to the direct action of the fire. In addition to this, the tubes are placed much wider apart than is possible in many forms of boiler, and there is consequently no liability of the filling up of the interstices. Internal flues are dispensed with, and with them a fruitful source of accidents, on account of their liability to become overheated and collapse.

These boilers may be modified in various ways, to suit different situations and requirements; and to meet the views of those who object to small tubes, the patentees have designed an arrangement with large flues.

The boilers are also well suited for exportation, as they may be very conveniently stowed, and, when detached, they are both of light weight and small size.

ANGLE-IRON SHEARING AND PUNCHING MACHINE, OF DUPLEX ACTION.

This excellent tool is the invention of Mr. Hugh Donald, of the firm of Craig and Donald, of Johnstone, Renfrewshire. It presents a most compact and efficient arrangement for the performance of the several operations of cutting or shearing, punching and riveting, within the limits of a single machine tool. Fig. 1 is a side elevation of the tool, divested of its driving gearing; and fig. 2 is a plan corresponding, the scale being $\frac{1}{4}$ inch to the foot.

It has a simultaneous quadruple action; that is to say, it is capable of both cutting and punching, or riveting, on each side, and all at the same time. It consists essentially of a main cast-iron frame, *A*, in the open centre of which a vertical lever, *B*, is hung on a horizontal axis of oscillation, *C*. The lower end of this lever is jointed to a connecting-rod, *D*, from a revolving crank, in connection with the prime mover; so that, as the crank rotates, this lower and longer arm of the lever is caused to vibrate. The head of this lever carries a cutter, *E*, on each side; the line of cutting being very little above the centre of oscillation, so that a powerful leverage is secured. The reverse or bottom-fixed cutters, *F*, corresponding to the moveable cutters, are set, one on each side of the lever, on the fixed frame; and thus, as the lever-head vibrates, its two

SMALL-DIAMETER STEAM BOILER.

MESSRS HOLCROFT & HOYLE, ENGINEERS, MANCHESTER.

Fig. 1.

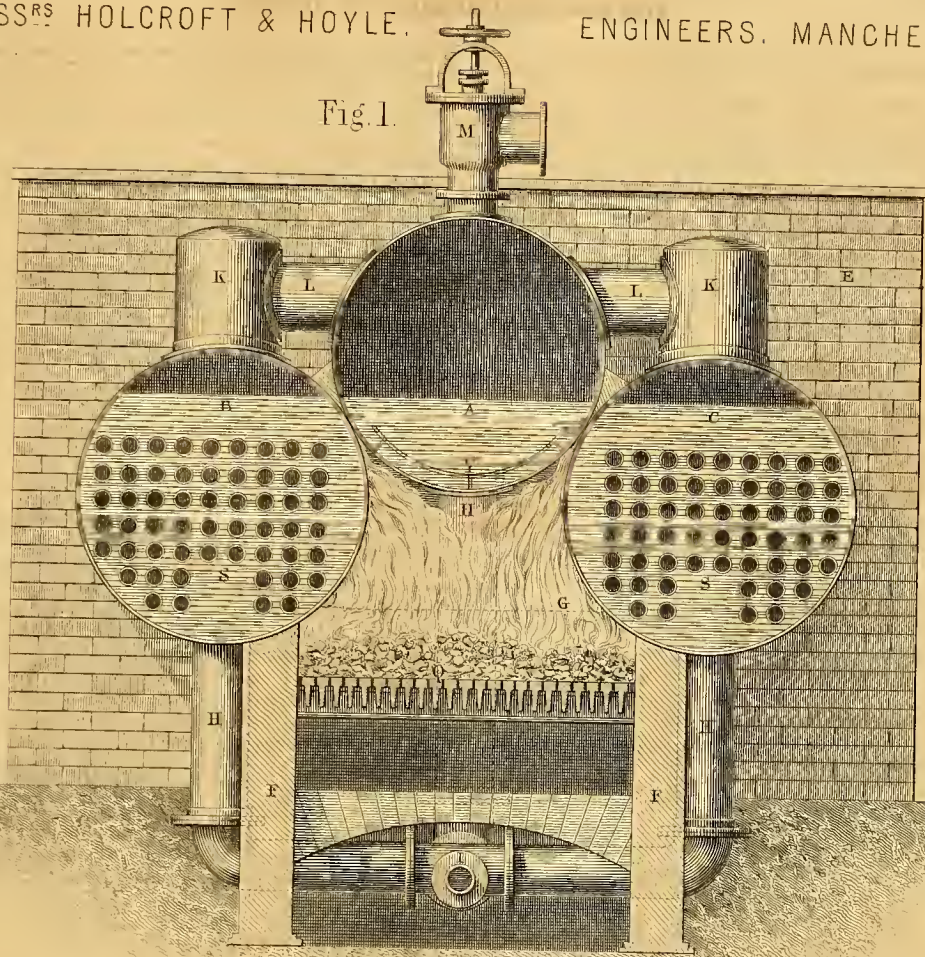

Fig. 2.

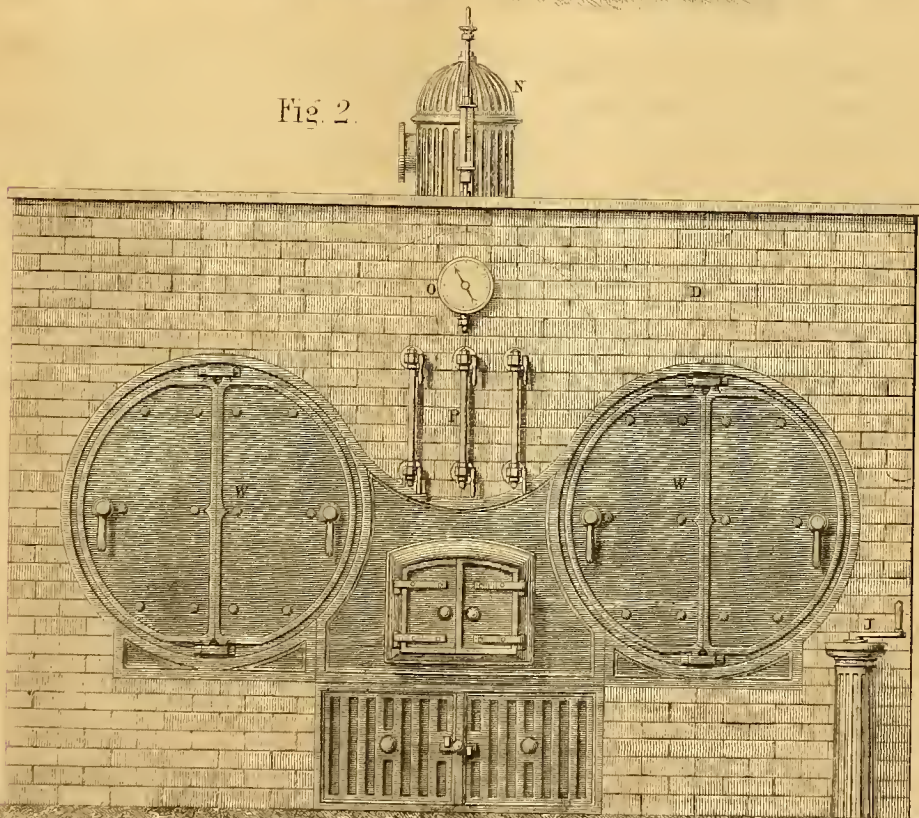

Fig. 5.

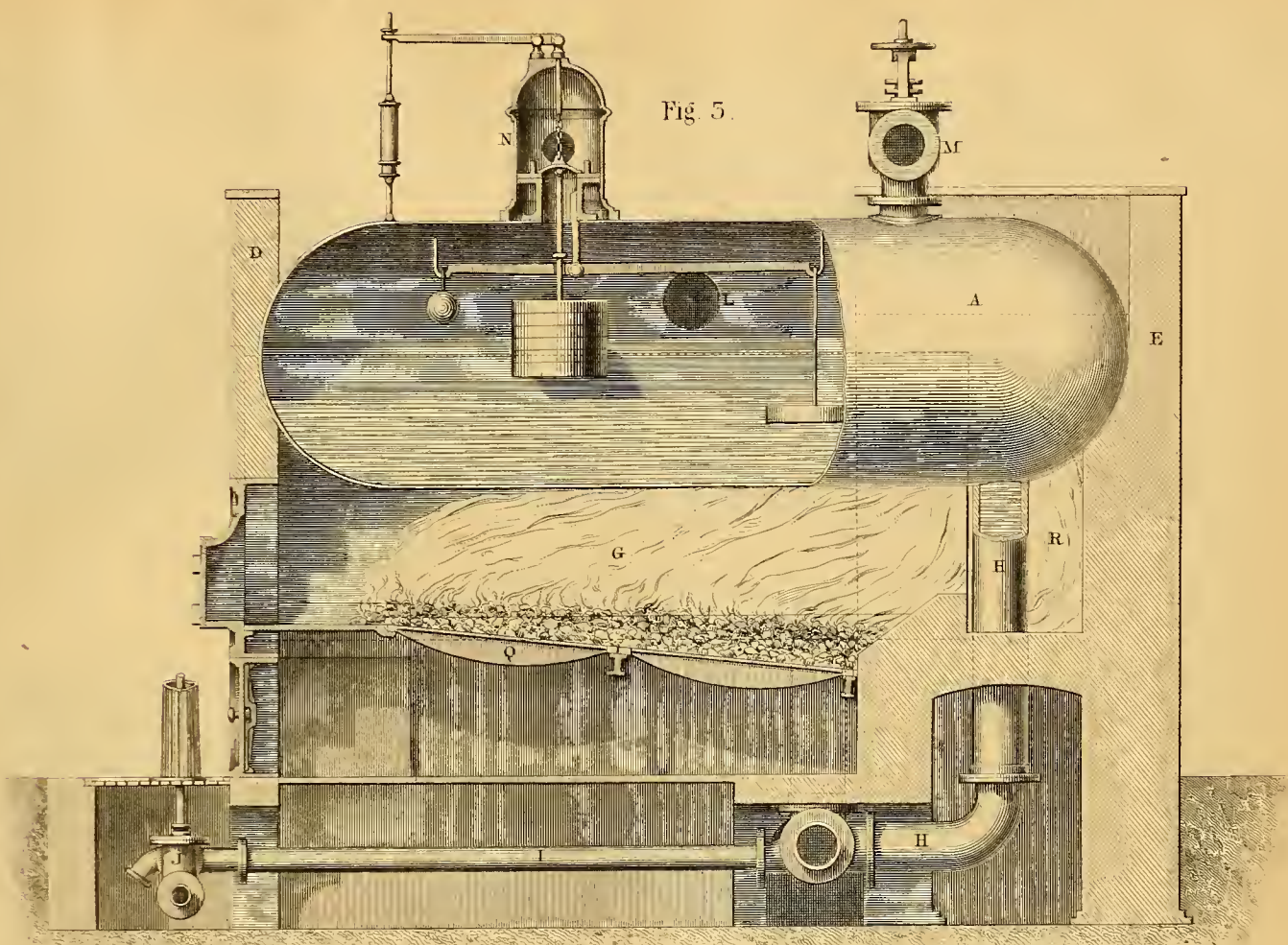
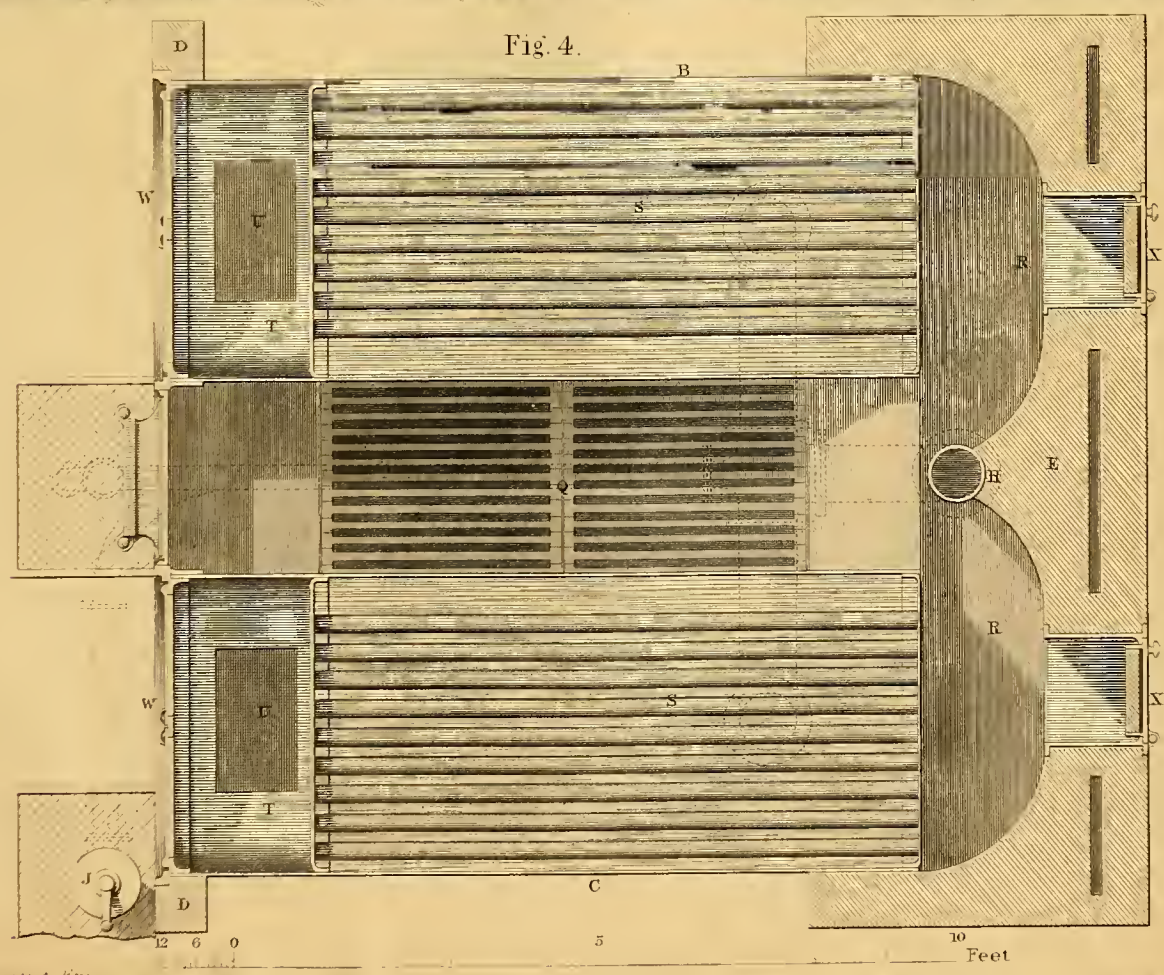

Fig. 4.



10 Feet

sides cut alternately. In this way, two men can cut or shear at once, the cutter ascending on one side, whilst that on the other descends; and

Fig. 1.

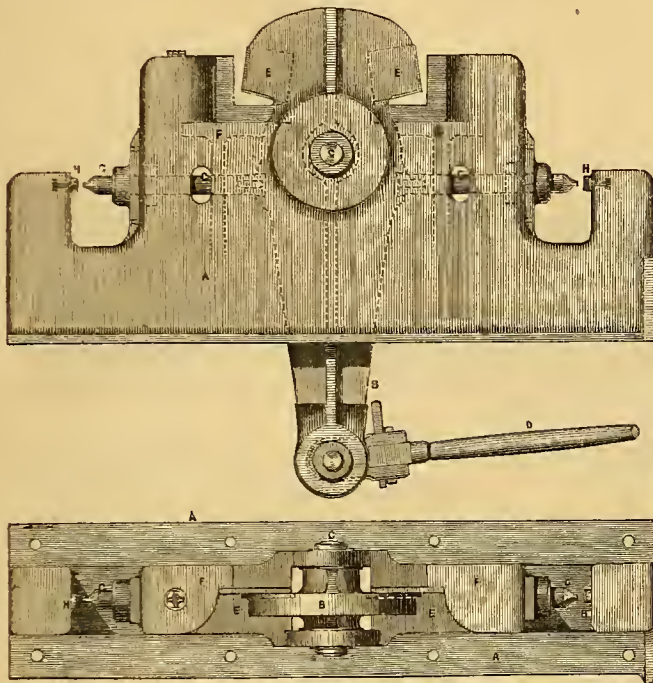

Fig. 2.—1-48th.

this enables the attendants to cut such pieces of metal as are troublesome to manage in the ordinary way, as, by giving one cut on one side, the piece may be completely severed by being turned to the other side. The punching and riveting actions are effected in a very simple manner, by setting the working mandrills, *e*, one on each side of the main lever, a little below the centre of oscillation. Each mandril works through a horizontal guide in the main frame, its inner end being linked to the side or edge of the lever, whilst its outer working end projects through the frame-piece, and comes up to a socket on a projection east on the frame. Thus, each mandril, working either a punch or riveting-piece, *h*, comes into action alternately. By this arrangement, the duplex-cutting action is kept in the centre of the heavy framing, whilst the punching and riveting operations are on a lower level at each end.

The general arrangement may be modified to a certain extent to suit special purposes; or, instead of setting the machine as described, it might be erected in a vertical position, with the main lever vibrating horizontally. The machine may, indeed, work at any angle.

The tool from which our drawings were made, is at work at the shipbuilding yard of Messrs. Lawrie & Co., Whiteinch, Glasgow. It is obviously enough a most valuable contrivance for the marine engineer.

MECHANIC'S LIBRARY.

Baths and Wash-Houses, imp. 8vo, 3s. 6d., sewed. G. A. Cape.
 Builder's Price-Book, 1854, 12mo, 4s., cloth. W. Laxton.

Builder's Price-Book, 1854, 8vo, 4s., sewed. Crosby.
 Builder's Price-Book, 1854, 8vo, 4s., sewed. Taylor.
 Chemical Recreations, tenth edition, first division, crown 8vo, 2s., cloth. J. J. Griffin.
 Concise Sections, Elementary Treatise on, 7s. 6d. G. H. Puckle.
 Curiosities of Industry, 8vo, reduced to 3s. 6d., cloth. G. Dodd.
 Dialling Diagrams, 12mo, 1s., sewed. W. Watson.
 Electricity, On Human, post 8vo, 6s., cloth. J. C. N. Rutter.
 Manufacturing Districts, Hand Book to, 12mo, 3s., sewed.
 Painter's and Grainer's Assistant, 6th edition, 12mo, 2s., sewed. Barber.
 Photography, Art of, 12mo, 1s., cloth, sewed. Halleur.
 Practical Assaying, Manual of, 2d edition, 8vo, 20s. J. Mitchell.
 Science and Art, Yearly Book of Facts in 1854, foolscap 8vo, 6s., cloth.
 Woolen Manufacturer's Guide, 12mo, 5s., cloth. G. Ibbetson.

RECENT PATENTS.

COMBINED SEED, MANURE, AND LIQUID DISTRIBUTOR.

W. C. SPOONER, *Southampton*.—*Patent dated June 30, 1853.*

This invention relates to the combination of a liquid supplier with a seed-box and manure drill, so that seed, manure, and water may enter the soil in close proximity with each other. Our engraving, fig. 1, represents the apparatus employed, in vertical section. *A* is the water-tank, composed partly of wood and partly of iron; it is supported on the stud centres, *B*, which rest in suitable forked hearings, *C*, bolted to the shafts, *D*, of the drill. *E, E*, are a series of valves, which are fitted inside the tank, serving to shut off the communications between the several compartments, such communications being opened, however, during the filling of the tank, in order that each of the compartments may be filled simultaneously. The whole of the valves are opened by the transverse rod, *E'*, worked by a handle outside the cart. A blade-spring is fitted to each valve, to keep it shut when the whole of the compartments are full. A series of cocks, *F*, are fitted to the bottom of the tank, each cock opening into a set of ordinary pipes or cans, *G*, which receive also the manure from the manure-box, *H*, and the seeds from the seed-box, *I*, such seeds being conducted therefrom by the inclined conductors, *J*, which open at their lower extremities into the pipes or cans, *G*. A perforated plate, *G'*, prevents the entrance of dirt into the cocks, which might otherwise become clogged up. The cocks, *F*, are opened or shut by means of the small spur pinions, *K, K*, fitted to a transverse shaft, *L*. These pinions gear with similar pinions, attached to the plugs of the cocks. The whole of the cocks may be opened or shut by means of the rod, *M*, which is connected to a lever attached to the shaft, *L*, the movement being trans-

Fig. 1.

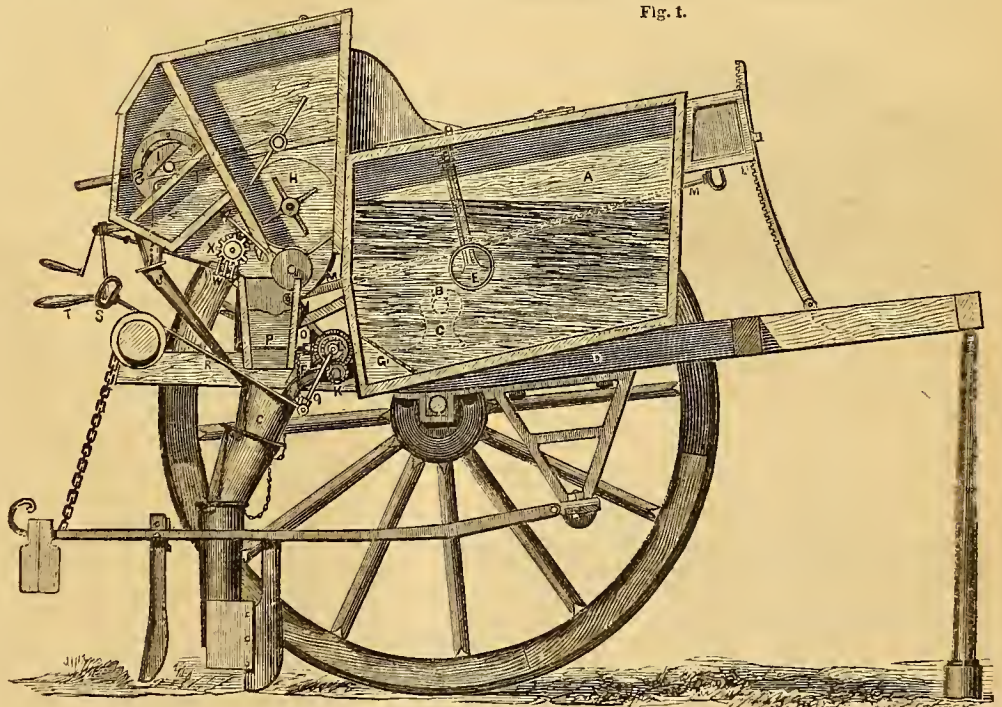

mitted by a pair of bevil pinions, *O*, to the spindle, *P*, which is fitted with an index, to show the position of the cocks to the drill-man in attendance; or the covers may be opened or shut by the lever, *Q*, also attached to the end of the shaft, *L*, and connected to the rod, *R*, formed with a handle, *S*, for inverting the lever. The body of the drill is adjusted or

turned on its centres, B, by the handle, T, and rack and pinion, U, in the ordinary manner. The arrangement described is obviously applicable to drills with any number of coulters, and the water-tank may be used either in conjunction with a seed-drill alone, or with a manure distributor, or simply as a water-cart.

MANURE DISTRIBUTOR.

W. TASKER, *Andover, Hants.*—*Patent dated June 30, 1853.*

This invention relates to a novel arrangement of mechanism for giving a regular and constant supply of manure from the manure-hox in manure distributors, and consists in placing a cylinder in the bottom of the box containing the manure. This cylinder is fixed, and a fluted cylinder revolves round it, the bars or projections of the latter being in contact with the exterior of the former, so as to form a number of cavities, into which the manure falls, and thence passes to the conducting spouts as the cylinder revolves. We have represented this manure distributor in combination with Mr. Spooner's liquid supplier, fig. 1 being a vertical section of the entire drill apparatus, and figs. 2 and 3 end and front views of the distributing cylinders on an enlarged scale. The manure-box, which is placed between the water-tank, A, and seed-supplier, I, is divided into as many compartments as there are coulters, and is provided with revolving agitators, R. Immediately below the agitator is the distributing cylinder.

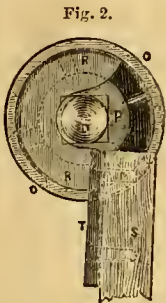
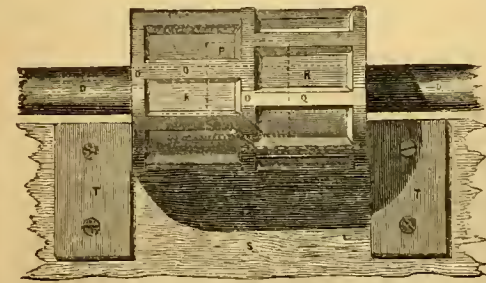

Fig. 2.

This cylinder is carried on the transverse shaft, n, figs. 2 and 3, driven by one of the running wheels of the machine, by means of intermediate external gearing. The outer moveable or rotatory part of the distributing cylinder, o, is cast with a central boss, p, which is fitted on to a square portion of the shaft, n. This outer cylinder consists of a series of transverse bars, o, which slide over the fixed segmental plates, r, hinged to the side, s, of the conductor, r (fig. 1), by the flanges, t. As the manure in the box, A, comes in contact with the revolving cylinder, it is conveyed into the conductor, r, whence it falls into the cans, c, and is deposited into the ground in the ordinary manner. The size of the openings through which the manure passes to the cylinders is regulated by the sliding-door, v, which is actuated by the screw, w, and pinion, x, the latter gearing with a rack on the body of the door, or sliding-plate, v. By this means the door is raised or lowered, and the apertures for the passage of the manure proportionately increased or diminished. By the employment of the peculiarly formed cylinders,

hereinbefore described, all chances of clogging or filling up is entirely obviated, since the constant traversing or rubbing of the outer cylinder over the fixed segmental plates, before mentioned, keeps the cylinder always clean.

Fig. 3.



WATER DIE FOR BRICK MACHINES.

JOHN HERITAGE, *Warwick.*—*Patent dated August 17, 1853.*

In brick and tile-making machines, great difficulty is ordinarily experienced in obtaining a smooth outer surface, owing to the adhesion of the clay to the dry unlubricated mouth-piece of the die. This defect is entirely obviated by Mr. Heritage's water die, or lubricated mouth-piece, which is represented in vertical section in our engraving, as applied to the well-known Beart Brick Machine. Outside the original mouth-piece, A, of the machine, a second one is fitted, consisting of a hollow conical casing, n, entirely surrounding the issuing brick, c, and having its narrow outer edge coincident with the outline of the latter. This casing, n, is supplied with water from the cistern, D, placed above the mouth-piece, by means of the pipe, E, fitted with a stop-cock to regulate the supply. By this means the issuing brick is efficiently lubricated, and is, in consequence, delivered by the machine with a perfectly smooth outer surface. In the pugging and expressing processes, quantities of

air are apt to become mixed up with the clay in a condensed state; and on leaving the ordinary die mouth, this air exudes from the brick with a slight explosion, very much roughening and injuring the surface. This defect does not exist where the secondary mouth-piece is employed, as the air escapes from the brick immediately on leaving the first die, and

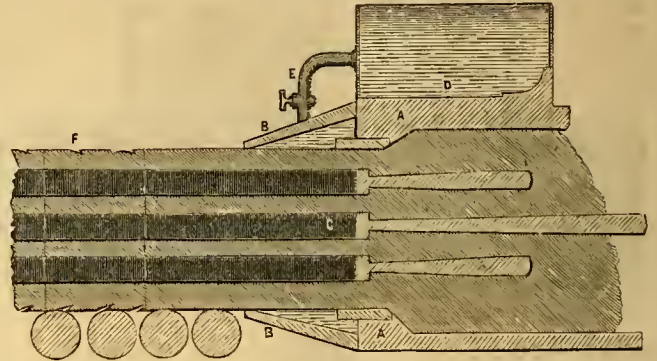

the surface is rendered quite smooth on its subsequent passage through the external die. In our engraving, the brick at F is shown as having exuded from the machine a short distance prior to letting on the lubricating water, the surface being cracked and rough, as in bricks produced by the ordinary dry-mouthed machine, whilst the succeeding portion, which has issued in a duly lubricated state, is recognizable by its smooth and perfect surface. This important improvement is being practically carried out by Messrs. Martin Samuelson & Co., of Hull.

NOISELESS POWER LOOM.

ROBERT BOYD, *Paisley.*—*Patent dated May 16, 1853.*

This inventor proposes a novel and very ingenious mode of actuating the shuttle in power looms, being a substitute for the ordinary picking mechanism at present in use, and consisting in the employment of the direct action of compressed air, steam, water, or gases, or of atmospheric pressure derived from exhaustion. In applying this system of working to large manufactories—if compressed air is used—an arrangement of pumps, or other compressing apparatus, is fitted up to keep an air reservoir constantly charged to the required working pressure; such reservoir is conveniently placed near the looms, and conducting pipes are led from the receiver, and made to branch off to each side of each individual loom. At each end of the loom lathe, or slay, is attached an air cylinder, fitted up with an air-tight piston, the rod from which projects from the inner end of the cylinder, and carries a suitable picker or driver adjusted to the line of traverse of the shuttle. In this way, by adding suitable valve apparatus and actuating cams or catches, the loom and slay motions are made to admit the compressed air to the cylinders at the required times, and the piston actions thus drive the shuttle across its race. When the shuttle arrives at the end of its run, its traverse action drives in the piston on that end of the lathe or slay, and thus prepares the piston for the return stroke; or, instead of this, a separate spring may be employed for retaining the piston at the commencement of its working stroke when unacted upon by the air pressure, or waiting to be put into operation. The air thus used for actuating the shuttle may be afterwards made to heat or ventilate the weaving shop.

Fig. 1 of our engravings is a front view detail of the air motive apparatus, showing the air cylinder as fitted up on the lathe end, with the shuttle in its box, or at the commencement of a "pick," and a portion of the reed and shuttle race; and fig. 2 is an external end elevation corresponding to fig. 1, and at right angles to it, showing the rotatory cam movement for regulating the air cylinder's action. A is the end standard of the framing, carrying the vibrating frame or lathe swords, B, in the usual way, for causing the vibration of the lathe, C. At each extreme end of the lathe is an air cylinder, E, of considerable length, but small diameter, and accurately bored out. This cylinder in each case is held horizontally in the end piece, F, of the lathe, between the fixed collar, G, and the end valve box, H, which is screwed on from the outside. The cylinder is thus held steady at its outer closed end, and it is retained at its opposite end by a collar piece or cap, I, screwed on outside the cylinder, and carrying a lug or eye for attachment to a steady guide rod, J, screwed at its opposite end to the lathe at K. The cylinder is fitted with an accurately working solid piston, L, the rod, M, from which works out through the cap, I, as a guide, and this

projecting end has upon it adjusting nuts for securing it to the cross angular end, *x*, of an external carrier piece, *o*. This piece extends back along the outside of the cylinder, and has an angle piece at its opposite end, carrying an elastic driver or "picker," *q*, for driving the shuttle, *r*, along its race, *s*. This carrier piece, *x*, *o*, has an eye, *t*, on its front end, *x*, entered upon the guide spindle, *j*, to secure a parallel picking action; and above this eye is a small flange for holding the end of an elastic band, *u*, the opposite end of which is screwed at *v*, to the lathe end, as a retaining spring for the piston. The valve case, *h*, which is screwed on at right angles to the cylinder's axis, has a bored collar guide, *w*, at its lower end, for the passage through of the actuating valve spindle, *x*, and its upper open end is closed by a screwed cap, *y*, formed to act also as a guide for the upper end of the valve spindle, which is

framing, into the line of reciprocatory traverse of the lower curved arm, *e*, of the lever, *c e*, carried by the vibrating lathe. Hence, the moment the lathe reaches its furthest back position, and when the "shed" of the warp is at its fullest extent, the lathe vibration strikes the lever arm, *e*, against the stud, *f*, as a stop. This action then causes the upper lever arm, *c*, to strike up the valve spindle, *x*, and thus admit a jet of compressed air through the valve from the upper side of the valve casing, into the space, *b*, between the closed cylinder end and the piston. The piston is thus rapidly carried to the other end of its cylinder, and by means of its picker, *q*, it throws the shuttle, *r*, to the other side of the loom, the air in front of the piston escaping from the cylinder by the small aperture, *l*. The back action of the lathe then releases the valve, which closes, and the reaction of the spring, *u*, then takes back the piston

Fig. 1

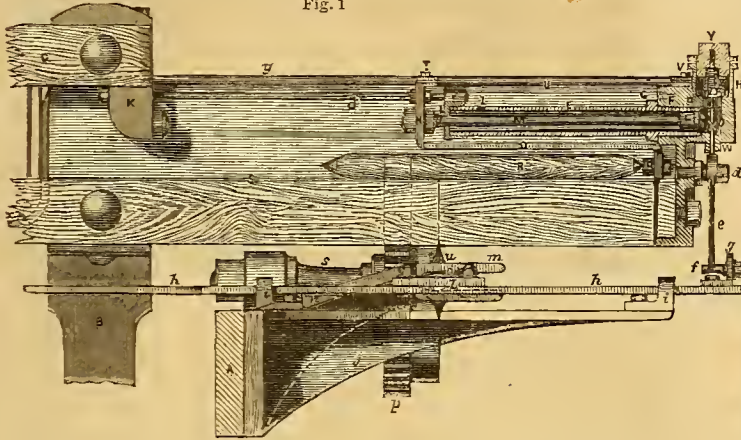
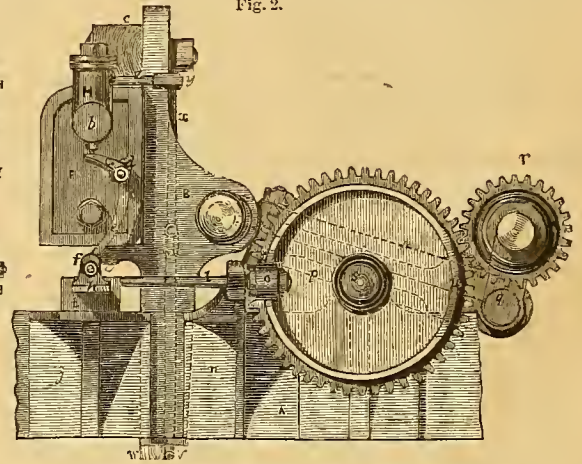

Fig. 2



encircled by a spring, *z*, to keep the valve down. The valve is a lifting disc fast on the spindle, and faced on its working surface with an elastic ring. It thus governs the communication between the upper part, *h*, of the valve casing, and the lower cell, *b*, the fixed working face being between these two sections. The lower projecting end of the spindle, *x*, rests upon the upper arm, *c*, of a curved lever working loose upon a stud centre, *d*, screwed into the end piece of the lathe. This curved lever has a lower arm, *e*, hanging downwards, so as to be within the sphere of action of a traversing stud, *f*. This stud, *f*, is secured into a carrying bracket, *g*, fast on one end of a long horizontal traversing bar, *h*, fitted to work in bracket guides, *i*, on the main bracket arms, *j*, bolted to the outside of the end standards of the framing. This bar has a constant tendency to be drawn towards the left side of the loom by the action of the helix, connecting the bar to the end standard on that side. At the right-hand end, this bar, *h*, has also bolted to it the broad flat end of an arm, *l*, extending back at right angles to the bar, and fitted into a horizontal guide slot, *m*, in the upper end of a separate bracket, *n*, bolted to the loom standard behind. This free end of the arm, *l*, carries a loosely revolving pulley, *o*, arranged to bear against the face of the cam ring of the combined wheel and cam, *p*, employed to work the picking movement. The crank shaft, *g*, which works the lathe, *c*, in the usual way, by means of connecting-rods, has upon one end a small spur wheel, *r*, in gear with the cam spur wheel, *p*, running loose upon a stud, *s*, carried on a bracket on the stationary frame. The cam face of this wheel consists of a differentially-curved ring, *t*, *u*, standing out at right angles to the wheel's face, a recess or curved hollow, *t*, being formed on one side, and a corresponding projection, *u*, diametrically opposite. The compressed air is brought to the loom through a line of pipes, which communicate with the flexible junction piece, *v*, at the centre of the loom, opening into the lower end of an inflexible pipe, sustained on a bar, *w*, at the centre of the vibrating lathe frame. From the upper end of this pipe, branches, *x*, pass right and left along the inner face of the lathe, bending upwards above the shuttle-box, as at *y*, and finally entering the back of the upper chamber, *h*, of the cylinder by the branch, *z*.

to its starting point, as shown in the figure, for a succeeding throw. Then, as the cam, *p*, revolves in the onward action of the loom, the pulley, *o*, is lifted out of the recess, *t*, and simply bears against the plain zero portion of the cam ring, so that the stud, *f*, on both sides, is kept clear of its corresponding vibrating valve lever. But, as the cam revolves, the opposite projection, *u*, comes into play, and acting on the pulley, *o*, draws the bar, *h*, as much beyond the zero line of the cam to the right as it formerly passed to the left. This, then, brings the stud, *f*, on the left of the loom, within the vibrating scope of the valve lever, so that the air valve at that side is opened, and the piston at once throws back the shuttle.

WINDOW SASH FASTENER.

W. WESTLEY and R. BAYLISS, Derby.—Patent dated December 23, 1852.

This simple and efficient sash-fastener is represented in the engravings annexed, fig. 1 being a vertical transverse section through one end of the fastener, fig. 2 a similar section through the central part, and fig. 3 is a section of a simpler form, without a locking catch, and intended for the windows of the upper parts of houses which do not require locking. The meeting bars, *A* and *B*, of the top and bottom sashes are respectively formed with a wedge-shaped catch, *C*, and socket, *D*, which

Fig. 1.

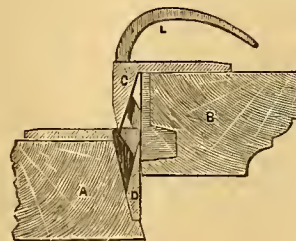
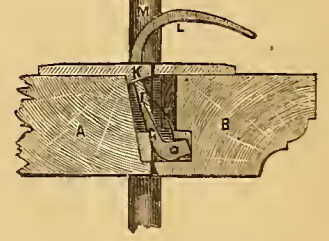

Fig. 2.



are so formed as to draw the bars forcibly together in closing. In the central part of the fastener, a lever, *c*, is hinged to the bar, *B*, and is forced forward by means of a spring, *u*, whilst a finger-piece is provided above for drawing it back. The lever itself projects into a groove in the socket of the bar, *A*, but it has a lateral projection, *i*, which enters

under the overhanging piece, κ , of the latter, so as to lock the two sashes securely together. m is the bead in the window-frame between the traversing grooves of the two sashes.

Fig. 3.

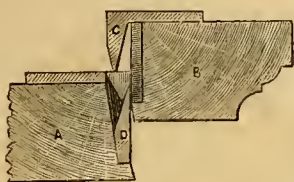

The arrangement represented in fig. 3 is precisely similar to the other one, except that the spring-locking catch is dispensed with.

By means of this fastener, the window is secured by the mere action of closing the sashes; and by attaching a hanging cord to the finger-piece, a window of any height may be opened without its being

necessary to mount a chair for the purpose of reaching the fastening, as it can be loosened by simply drawing the string.

SHIPS AND BOATS.

F. LIPSCOMBE, *Temple Bar, London.*—*Patent dated June 7, 1853.*

There is no subject embodying the application of mechanical principles upon which so much difference of opinion exists among scientific men, as the form of sailing ships and boats. Mr. Lipscombe, in endeavouring to solve the grand problem as to what is the best form for speed, buoyancy, and stability, has investigated it in a novel and original manner, and, striking out a path totally different from that pursued by earlier inquirers, arrives at conclusions rather at variance with received opinions. Like others, Mr. Lipscombe makes the bows of his ship in the form of a wedge, but, instead of giving a vertical position to this wedge, he arranges it horizontally. In other words, he makes the under forebody of the ship of a nearly flat form, inclined to the surface of the water, and increasing in depth towards the after part of the ship, as far as a certain point, behind which it again rises, coinciding with the surface of the water at the stern. The resistance met with by a ship is lessened in proportion as her wedge-formed bows exceed in length her greatest width. According to Mr. Lipscombe's theory, this principle is true, whether the wedge be vertical, and compared with the width, or horizontal, and compared with the depth; whilst the broad flat shape accompanying the latter disposition of the wedge form are superior in point of buoyancy and stability. On the strength of his convictions, Mr. Lipscombe has accordingly patented the form of vessel described, and there is some chance of his principles being put to a practical test.

SHIPBUILDING TEMPLATES.

ANDREW BURNS, *Glasgow.*—*Patent dated July 12, 1853.*

This invention relates to an improved arrangement of template for setting out and marking the correct situations of the rivet or bolt holes in the plates and frames, together with the exact shape of the plates used in the construction of iron ships and other metallic structures.

According to the ordinary and general system of constructing iron vessels, the workman finds it necessary to take each individual plate intended for the actual shell of the vessel to its allotted place in the vessel as the building proceeds, and he there temporarily fastens the plate, and then ascertains its intended accurate finished shape, and the position of the rivet or bolt holes, by such actual fitting or adaptation to the structure in progress; and having thus set off and marked the required points, he disengages the plate, and conveys it from the vessel or structure to the punching and shearing machine, and having cut and punched the plate as required, he reconveys it to its proper position in the vessel, where it is finally fixed.

This routine of construction is well known to be attended with very considerable loss of labour and time; and, as the pitching or setting out of the holes is committed to different workmen, errors and irregularities in the pitching are of frequent occurrence.

According to Mr. Burns' improved system, the structure is commenced with the regular pitching of the holes through the frames which hold the shell plates, a template or guide frame of wood or metal, arranged in the form of an open parallelogram, being used for this purpose.

Fig. 1 of our engravings represents one form of Mr. Burns' template. The main longitudinal or side pieces, A , are made up of a series of separate lengths or sections of metal plates, placed end to end, and overlapping each other. These lengths are bolted together by lateral overlapping pieces, B , the bolt holes in which are elongated to admit of a slight longitudinal adjustment; each length is in two pieces, jointed together, as at B' , to enable the whole to be set more accurately to a curved plate when required. The figure represents the under face of the template—that is to say, that side which is applied to the frames of the ship. The

immediate contact of the template with the ship frames is by means of the pieces, C , riveted to each length of the longitudinal bar, A , and made of a thickness sufficient to keep the heads of the junction bolts, D , from touching the ship frames. The longitudinal bars, A , are each pierced with one or more rows of holes, corresponding to the holes along the edge of the plate, and by which the latter is riveted to the one next to it. The sections of the longitudinal plates, A , correspond in length to the distances between the ship frames, and each section is provided with a cross bar, H , which, whilst it serves to stiffen the entire template, is chiefly for

Fig. 1.

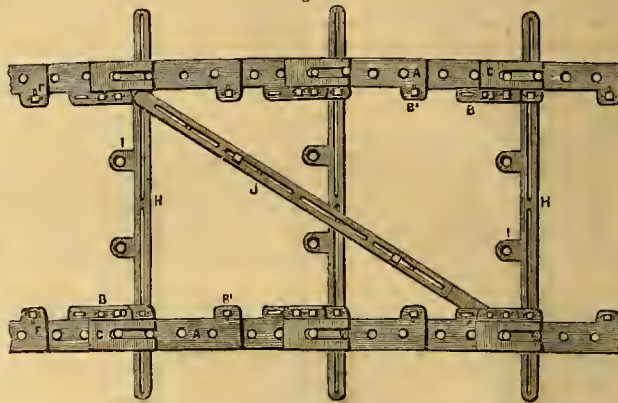

the purpose of taking off the positions of the holes on the frames, by means of which the plates are attached to the frames. The cross bars, H , are slotted longitudinally for adjustment upon the longitudinal plates, A , by bolts, and are formed with projections, I , with round holes, which, being set to the holes in the ship frames, serve to mark the corresponding holes in the plate. To prevent the angular working of the template, a diagonal stay, J , is bolted to any diagonally-disposed points of connection of the longitudinal plates, A . The stay, J , is made in two or more pieces, united by bolts and slots, so as to be adjustable in length. In setting the template, the various connecting bolts being loosened, the cross bars, H , are applied to the edges of the ship frames, and the different parts being shifted, as the case may require, the bolts are screwed tightly up, and the entire template frame is removed from the ship's side, and applied to the plate to be punched and cut, when the outline and the various rivet holes may be marked off with the greatest facility.

In the modification represented in fig. 2, are comprised several contrivances for varying the pitch and positions of the rivet or bolt holes.

The longitudinal bars, A , are formed with elongated holes for marking the rivets, and the actual positions of such rivet holes are defined by a plate, or pair of plates, laid upon the plate, A . Such a pair of plates are represented as detached, at B, C ; they are of any convenient length, such as the space between two frames, for example, and are pierced with marking holes arranged in any desired manner. They have also slots, D ; and the longitudinal plate, A , is provided with pins, E , at suitable positions, upon which plus the slots of the plates, B, C , are entered, and the latter are thereby made capable of longitudinal adjustment upon the plate, A , so that the positions of the rivets may be determined in the best manner. Where there are two rows of rivet holes, it will often be desirable to adjust one row independently of the other. In this case two plates will be required,

Fig. 2.

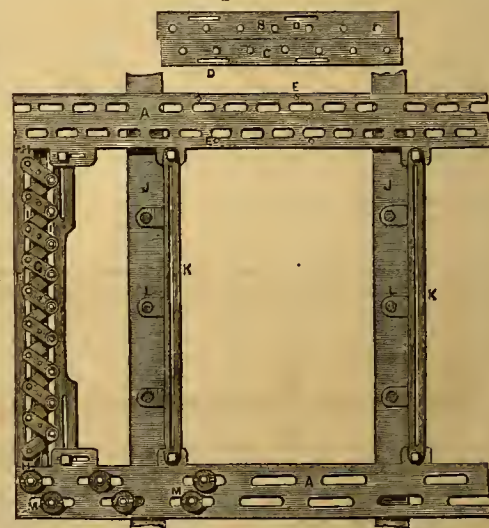

Where there are two rows of rivet holes, it will often be desirable to adjust one row independently of the other. In this case two plates will be required,

as represented, but in other cases a single plate will be sufficient. The end plates, *r*, of the template, represented in this figure, are fitted with rivet-hole markers of a varying pitch. These markers consist of a series of short plates, *e*, articulated together, and made with tubular joints, which serve as marking holes for the rivets. The extremities of this series or chain of plates are jointed to projections, *n*, on the two adjacent ends of the longitudinal plates, *a*, and a pin is fixed to the centre of the under side of each plate, *e*, which pin works in a guide groove in the end plates. On either side of the plate, *r*, are two slots, *i*, which lie immediately below the tubular joints of the plates, *e*, and admit of the rivet holes being marked through them. The plates, *e*, are disposed in a zig-zag manner, the joints being alternately over the two slots, *i*. By this arrangement, the pitch of the holes adjusts itself to the width of the plate, for as the longitudinal plates, *a*, of the template are brought nearer together, the zig-zag chain contracts, and so reduces the pitch of the holes. If, on the other hand, the longitudinal plates, *a*, are set further apart, the zig-zag chain will be elongated, and the pitch of the holes correspondingly increased. The slots, *i*, are made sufficiently wide for the lateral variation of the tubular joints, which is in proportion to the variation in the chain's length. The template is represented as applied to the frames, *j*, of a ship, and the marker holes, *l*, on the cross bars, *k*, are supposed to be set for the bolt holes on the frame. Instead of the plates marked, *b*, *c*, a series of adjustable hole markers, *m*, may be used in the elongated holes of the frames, *a*. These markers consist of short collared tubes, which are entered through the slot in the template, and secured by a collar screwed upon the end projecting through the plate. These markers can be set and screwed in any position, and may be employed in combination with slotted longitudinal cross or diagonal bars, in any of the described modifications.

ROTATORY ENGINE.

A. PARSEY, London.—Patent dated June 15, 1853.

The main working chamber of this engine consists of a cylinder, *A*, the ends of which are provided with stuffing-box hearings for the passage of the main shaft, *B*. This shaft lies parallel to the axis of the cylinder, but is placed a little on one side. A cylinder, *C*, is keyed upon the shaft, *B*, and is of such dimensions as to touch the outer cylinder, *A*, at one side, whilst, on account of the eccentricity of the shaft, a lunate space is left towards the other side. The inner cylinder, *C*, is formed with grooves or cavities, extending the whole length of the cylinder, in which are fitted the pistons or paddles, *N*. Two or more of these pistons may be used; but they are in all cases disposed so, that each one has another diametrically opposite to it. A helical spring, *E*, is placed centrally between each pair of pistons, and is kept in position by a rod passing from one piston to the other, and working loosely in a socket in each. The spring and rod pass through an opening in the main shaft; and two or more such springs may be employed, according to the length of the cylinder. The springs serve to keep the pistons pressed in a steam-tight manner against the outer cylinder, whilst they allow for the variation of the diametrical length of the pair of pistons, as they revolve and assume different positions in the cylinder. Owing to the eccen-

tricity of the shaft, *B*, from which they radiate, the inclination of the pistons, *N*, to the outer cylinder, *A*, is different at different parts of the revolution. To compensate for this, and at the same time obtain a sufficient surface for acting upon the outer cylinder, the pistons are formed with self-adjusting heads, *F*, similar in principle and form to those employed by Messrs. Wright and Hyatt in their elliptic rotatory engine.

Mr. Parsey's engine somewhat resembles Mr. Borrie's in general principle. As one piston recedes into the cylinder, *C*, the opposite one emerges; and when one is pressed in altogether, as at the point where the inner cylinder, *C*, touches the outer one, *A*, the opposite piston is pressed out to its fullest limit. The cylinder, *A*, is provided with two ports, *G*, *H*, for the entrance and exit of the steam, according to the direction in which the engine is to turn. The steam enters the lunate space between the two cylinders; and as a piston is always interposed between the entrance and exit passages, the steam acts upon this piston, and thereby turns round the cylinder, *C*, and with it the shaft, *B*.

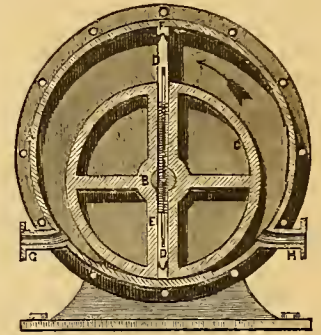

REGISTERED DESIGNS.

AMERICAN ENVELOPE.

Registered for MESSRS. WATERLOW & SONS, London Wall.

This envelope possesses peculiar features of security—obtained, too, in a very simple manner—by cementing the whole of the flaps to one another. Our figure represents the envelope in its complete state, but with its seal-flap open, as it would be when a letter is about to be enclosed in it. The two end flaps are made to overlap each other considerably, the flap, *A*, passing beneath the opposite one, as shown by the dotted line, *B*, and these junction surfaces are well cemented together. The bottom flap, *C*, is then folded down over these joined ends, and made to overlap them also, with a cemented junction. The seal-flap, *D*, is contrived so as to overlap the bottom flap, *C*, but slightly, so that all the four flaps are at once securely connected by the seal when the envelope is fastened up.

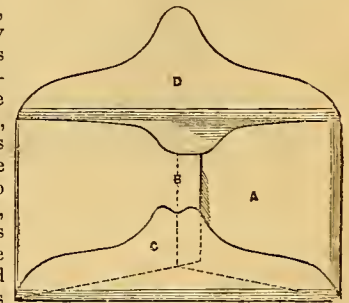

CORRESPONDENCE.

THE MECHANISM OF CARRIAGE WINDOWS.

Fig. 1.

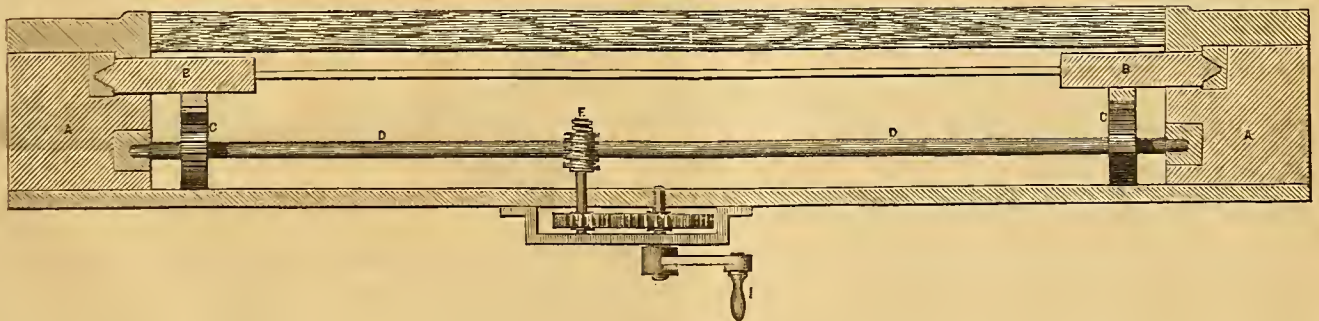

Having frequently been struck with the great inconvenience arising from the present mode of opening and shutting the windows of carriages,

and more particularly those of railway carriages, I have ventured to submit what I think would be a very simple and cheap apparatus for

effecting that object in a more satisfactory manner. It will be more easily understood by the enclosed rough sketch, in which fig. 1 represents a section of the window and frame; fig. 2 simply shows the action of the wheelwork. A is the framework of the door, and B that of the window, to which latter a rack and pinion movement, C, is fitted. This is driven by the horizontal shaft, D, carrying a worm-wheel, E, in gear with a worm, F, fast on a short transverse spindle, driven by a wheel and pinion movement, G, H, from an ivory handle, I, projecting inside the carriage.

Fig. 2.



The action will at once be understood by any of your mechanical readers, but it may be well to state that the worm and worm-wheel are introduced for the purpose of retaining the window at any required height in opening or shutting it, and the pinions, G H, are for the purpose of increasing the speed from the action of the handle.

The shafts and pinions, having only the weight of the window to lift, would only require to be made as light as possible; and, to resist the action of the weather, would be better made of brass.

Bolton, Feb., 1854.

J. H.

REVOLVING GUN BATTERY.

It appears to me that a great improvement might be made upon the ordinary stationary gun batteries of forts, by arranging the guns so as to be capable of revolution upon a circular platform. Such a plan is represented in vertical section in my sketch. Here A is a metal platform, of

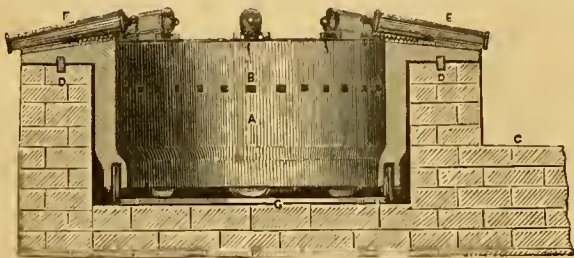

annular form, having a deep collar or cylindrical portion sunk into the battery wall. The bottom of this well or recess has upon it a circular rail, on which the platform rests by a ring of carrying wheels, so that, on the application of levers to the side holes, B, from the interior, the entire platform may be easily turned round. The portion, C, of the masonry is an external platform on the landward side, whereon the men stand in loading. The upper annular portion of the platform is similarly borne by a ring of wheels, D, running in a channel rail on the top of the tower. The guns, E, are ranged in a radial direction upon this portion, each gun being fitted with a helical spring, to receive the firing recoil. The gunners are placed inside the platform well, completely out of the reach of the enemy's shot, whilst the men intrusted with the loading are equally well shielded behind the tower. As each gun is fired, the platform is swung round, to bring the succeeding gun in the circle to bear seaward, and at the same time bring the discharged guns opposite the loading platform.

Edinburgh, Feb., 1854.

G. E. BURTT.

FIREPROOF LATHS.

Of the different materials which have been used as substitutes for laths in ceilings and partitions, I am not aware of slate having been tried. The slate could be cut into strips of the same breadth as a lath, and after a hole is drilled in each end of the strip, it could be nailed to the joist in the same manner as a wooden lath. The strips of slate would be heavier than wooden laths, but the difference of weight in comparison to that of the whole ceiling would be very trifling.

On the other hand, slate has the advantages of being fireproof and imperishable; these are two important considerations in its favour, especially in public buildings, where safety and durability are most required, and in private buildings these considerations do not become of less consequence. It may be said, that in those ceilings where wooden laths are used—while the ceiling remains entire—they obstruct the progress of the fire just as much as if they were of an unflammable nature. This may be true when the extent of the fire is small, and the heat not

sufficient to penetrate the plastering; but, as soon as the fire has gained the ascendancy, the ceiling will no longer remain entire, and after it is broken up, the laths powerfully aid the conflagration. Slate, on the contrary, will assist in subduing the flames by falling on the burning materials, and covering them with a fireproof coating. And when the building is taken down, at a period long after the wooden laths would have become useless, the slates would again be fit for use, if taken off entire.

The adhering surface of the strip might be increased by perforations made in the middle in a line parallel to its length; but this will, perhaps, not be necessary.

In the quarries where the slate is worked, there will doubtless be pieces not broad enough to make roofing slates, and also roofing slates chipped or broken in process of cutting, which would be suitable for cutting into strips, thus making a profit to the proprietor of what would be otherwise useless, and at the same time lowering the price to the consumer.

February, 1854.

KENNETH.

RATCHET BRACE AND SELF-ADJUSTING SCREW-KEY.

Fig. 1.

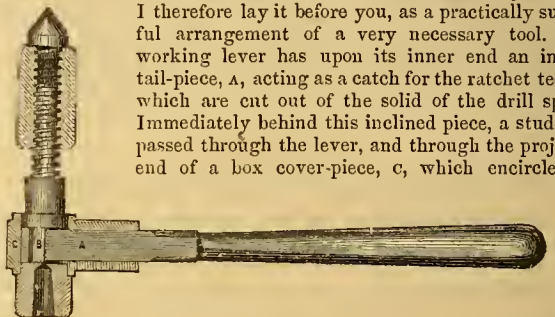

The ratchet brace, represented in longitudinal section in fig. 1, and in sectional plan in fig. 2, of my sketches, has been in use for five or six years; and I therefore lay it before you, as a practically successful arrangement of a very necessary tool. The working lever has upon its inner end an inclined tail-piece, A, acting as a catch for the ratchet teeth, B, which are cut out of the solid of the drill spindle. Immediately behind this inclined piece, a stud-pin is passed through the lever, and through the projecting end of a box cover-piece, C, which encircles and

totally covers up all the working details. This box is of malleable cast-iron, and the working end, A, of the lever is steeled. In working, when the lever handle is pushed from the operator, the tail, A, recedes from the ratchet tooth with which it is engaged, passing round without noise or

Fig. 2.



friction; and when the handle is drawn in the reverse direction, the tail, A, immediately takes its bite upon the next tooth, so as to carry the spindle round with it. The working parts of this drill are thus well protected from external dirt, and the movement is rendered quite noiseless.

Fig. 3 is a partially sectioned view of my self-adjusting screw-key, in which the lever is set upon a stud, A, beyond which a toothed rack-

Fig. 3.



piece, B, projects, so as to gear with corresponding teeth on the edge of a sliding-piece, carrying the moveable jaw, D. Thus, as the lever is pulled round, the rack action forces the sliding-jaw up to its work; and hence the key can never slip round, and pass the corners of the nut. The hold is obviously slackened the moment the working strain is removed. This key is very effective in working old and worn nuts, round which a common key would easily slip.

London, February, 1854.

ALEX. CLARK.

PROCEEDINGS OF SCIENTIFIC SOCIETIES.

INSTITUTION OF CIVIL ENGINEERS.

JANUARY 24TH AND 31ST.

"On the Drainage of the District South of the Thames," by Mr. J. T. Harrison.

On reading the minutes of discussion of the meeting of January 24th, attention was directed to the statement of the experiments recently made at Alowick, on the quantity of water discharged through a "pot-pipe," of eighteen inches diameter; for while, on the one hand, the results of the experiment sufficiently confirmed the accuracy of the formulæ of Du Buat, Eytelwein, Smeaton, Prony, Hawksley, and other investigators, and as decidedly contradicted the results published in the Blue Books emanating from the Board of Health, these results, nevertheless, differed too considerably from other consistent conclusions to be fully relied upon; and it was, therefore, desirable that this experiment should not be taken as a datum upon which to found any hydraulic law, for the determination of the quantity of water which might be transmitted through tubes. For this purpose, indeed, the cited experiment must be deemed unsatisfactory; because pot-pipes were never of uniform or exact diameter—inclinations were always, more or less, vaguely stated—joints were seldom sound, and when the discharge was into free space, the differential level was rarely satisfactorily afforded. Moreover, this experiment itself was, in some respects, contradicted by very carefully conducted experiments, made by Monsieur Complet, at Versailles, on a pipe eighteen inches in diameter, the results of which were extremely consistent with the mathematical determinations successfully resorted to by all practical hydraulic engineers.

The experiment by Monsieur Complet was made on a pipe of 43,200 inches long and 18 inches diameter, the motive head was 145 inches (all French measures), the calculated velocity was $40\frac{1}{2}$ inches, while the observed velocity was $39\frac{1}{2}$ inches, differing from the velocity calculated from established formulæ only about 3 per cent.

It was also contended to be extremely undesirable that centralized authorities should continue to exist, as it was uniformly found that these authorities did great mischief by the wide dissemination of errors, apparently under Government influence, and by the consequent repression of scientific and practical improvements.

"On Macadamized Roads for the Streets of Towns," by Mr. J. Pigott Smith.

The lengthened experience of the author, as surveyor to the corporation of Birmingham, having under his charge about 150 miles of street road, and 50 miles of turnpike road, enabled him to express confident opinions on the comparative cost, durability, and general qualities of paving, and of broken stone for roads, and even for streets, subject to a considerable amount of heavy traffic.

The parties chiefly interested in having good roads were shown to be the owners of carriages and horses, and the rate-payers, at whose expense the roads were originally constructed and subsequently maintained. For both these classes, cheap roads (i. e., those of small first cost) were contended, generally, to be the dearest; horse-power being uselessly expended, carriages destroyed, and constant repairs to the surface of the road being necessitated. Any undue increase of tractive power was shown to fall indirectly on all who purchased any commodities conveyed through the streets, and the annoyances and hindrances to commerce, arising from ill-paved, or ill-kept, muddy, dirty, and noisy streets, were patent to all. The necessity was thence deduced for having the roads and streets so constructed, that the surface should be firm, even, and smooth, without being slippery, and be free from mud, or dust, or loose stones.

To attain this, the foundation should be of firm material, well consolidated, and perfectly drained, then covered with stones, broken to uniform dimensions, well raked in, and fixed by a binding composition of grit, collected during wet weather by Whitworth's sweeping-machine, and preserved for the purpose. This binding being regularly laid on, and watered, if in dry weather, would, in great thoroughfares, consolidate the new metal in a few hours, preserving the sharp angles of the stones, which assumed all the regularity of a well-laid pavement, with a considerable saving of material, and a firmer crust than by the ordinary method of allowing the vehicles to pass for many days over the uncovered surface of the new stones, grinding off the angles with a deafening noise, and forming dust, or mud, to be carried on to the footpaths, and into the houses and shops.

Instances were given of the advantages of this system, of using the grit for binding, which should, however, be that collected by the sweeping-machines, and not mere slimy mud.

A street in Birmingham, subject to great traffic, had been thus perfectly made and consolidated in five days, whereas, under the ordinary system, three months would have been required to produce the same effect.

The repairs were capable of being effected at any period of the year; under no circumstances were the street surfaces permitted to be worn down, and they were never stopped, as was the case for lifting and repaving.

Rules were then given for keeping the surface in perfect travelling order, for picking off all loose materials, for sweeping and never scraping, for preserving the profile of the surface and getting rid of all lodged water, for light watering in dusty weather, and heavy watering when there was adhesive mud that could not be otherwise removed by the long brushes of Whitworth's sweeping-machines, which were contended to be indispensable for keeping roads and streets in good repair, and for preventing the nuisances of mud and dust.

The system employed in London of heavy watering, without removing the mud, or of scraping and of hand-sweeping and lifting by shovels into carts, was shown

to be had and expensive. The loss of speed, and the extra power required to be exerted by horses drawing carriages over street surfaces in the state of those in London, were shown to be as much as twenty-five per cent. as compared to the work done in Birmingham. The employment of a better system, combined with the use of the sweeping-machines, had been productive, at Birmingham, of an economy of nearly one-third of the materials employed for the construction and repairs of the streets and roads.

Instances were given of the actual results of the system of washing and sweeping parts of the Quadrant, Regent Street, where the method had been satisfactorily proved to have produced superior effects, but prejudice had induced obstinate adherence to the old system, to the annoyance of the public, and with the derision of all foreigners who visited the metropolis. The actual state of all the leading thoroughfares could vouch for the justice of the criticism on the present metropolitan system.

The greatest amount of wear and tear of macadamized street surface in Birmingham, was shown to be four inches per annum; the average might be therefore taken at two inches; the cost of maintenance was fourpence per superficial yard, and that of watering and cleansing was twopenne, giving a total of sixpence per yard per annum.

Paving cost fifteen shillings per yard; it required to be renewed once in fifteen years, and the cleansing cost about one halfpenny per yard. Paving was, therefore, evidently about double as expensive as macadamizing at Birmingham.

It was, therefore, contended, that macadamized roads and street surfaces, if properly constructed and carefully managed, well water-cleansed for mud and watered for dust, brushed or swept by machinery, maintained with a uniform surface, and not permitted to become degraded, were well adapted for towns and cities of average traffic, and for many localities in and around the metropolis.

FEBRUARY 7.

"Description of the Navigation and Drainage Works recently executed on the Tidal portion of the River Lee," by Mr. N. Beardmore.

FEBRUARY 14 AND 21.

"On the Principles and Construction of Locks," by Mr. A. C. Hobbs. The author's object was to give a brief review of the mechanical principles involved in the construction of locks, and the degree of security hitherto achieved by manufacturers.

The paper commenced by asserting, as an axiom, that the highest point of security to be attained in the construction of locks, must consist in the fact, that the possibility of picking or opening them, without their true keys, should depend entirely on chance; and that, notwithstanding the immense variety of locks already invented, there were really but three absolutely distinct principles involved in their construction—so classed without reference to dates and for convenience of description.

The first principle included all locks having a series of fixed obstructions, or wards, in and about the key-hole, to prevent any instrument, except the key, being turned in the lock; this principle was shown to be inefficient, however complicated the construction might be, as the wards themselves afforded the means of ascertaining the form of key required to open the lock.

The second principle was that of the letter, or puzzle lock, which appeared to carry out the principle, or doctrine of chance, to the fullest possible extent. But in this case, also, a method was shown by which the lock could be opened as easily as in the former—proving that the inventor of that class of lock had failed to accomplish the object of producing a fastening whose security was dependent only on mere chance.

The third principle, or last class of locks, included all those possessing a series of moveable pieces, called slides, pins, tumblers, &c., placed within the case of the lock, and which pieces must be operated upon and moved into certain given positions by a key, before the bolt could be shot. This principle was illustrated by descriptions of the Egyptian lock, the Bramah lock, the inventions of Barron and of Bird, the detector of Mitchell and Lawton, and the later improvements of Chubb and of Cotterill (of Birmingham) and others. Allusion was then made to the great reliance which, until recently, had been placed on these locks, and an explanation was given of the principle on which all locks of this description could be as easily picked as their predecessors.

The author then commented on the necessity of devising some simple and effective means by which the defect, common to all the above locks, might be remedied, without adding materially to the cost. This desideratum he had endeavoured to secure, by the introduction of what was called a moveable stump, which projection, instead of being riveted into the bolt, was fixed to a piece moving upon a centre, or pin, at the back of the bolt. The action of that piece was such as to render it impossible to ascertain the true position of the tumblers; for, on any pressure being applied to the lock for that purpose, the stump, by its motion, locked the bolt, and left the tumblers at perfect liberty. The author stated his conviction that this apparently slight alteration rendered it impossible to open such a lock, except by the mere chance, or accident, of a key fitting it—there being no possible means of ascertaining the form of key requisite to open it surreptitiously. Since the introduction of this lock, several attempts have been made to produce the same result, without actually copying the exact original, but with very little success.

An additional principle of security, devised in America, was then pointed out in the celebrated permutating bank lock, invented by Robert Newell, of the firm of Day and Newell (New York), of which inventor Mr. Hobbs was the proprietor in this country. Previous to the introduction of that system, permutating keys had been used, but they required that the lock itself should be altered to suit any new adjustment of the bits of the key; whereas, in the American lock, the key

DECEMBER 14.

HARRY CHESTER, ESQ., IN THE CHAIR.

alone, being altered, produced by its own action the corresponding arrangement in the lock; by this ingenious contrivance, the person using the lock became his own lockmaker, and was able to render the key useless to any other person, by a simple change in the bits after locking the door. Such locks, whose numbers of permutations varied from 720 to 479,001,600, according to the number of bits in the key, were intended principally for strong rooms of banks, and other establishments where large amounts of property were deposited; they were therefore comparatively expensive, and were necessarily of larger size than locks required for ordinary use.

In conclusion, it was remarked, that questions would continually arise as to the violability or inviolability of particular locks, and especially of new inventions. The author, however, claimed to have established, that any new modification or arrangement of the parts of locks, which did not affect the principle of construction, could have no particular claim to security; or conversely, that if it could be shown that any lock was constructed on a principle not hitherto violated, it might be deemed secure, but certainly not unless such a claim could be made good. In respect to the locks alluded to in the paper, the author justified his statements by the two facts, that he had not only elucidated the principles on which all such locks might be picked, but that he had actually performed all that had been described. Finally, a hope was expressed, that whatever had been done and said to enlighten the public as to the insecurity of many locks now in use, instead of causing any unpleasant personal feelings, would stimulate lock manufacturers to produce what was really required, viz., secure locks, adapted to all purposes, of good workmanship, and at a moderate price.

Discussion "On the Principles and Construction of Locks," by Mr. A. C. Hobbs. "Description of Martini's Improved Jacquard Machine," by Mr. Laforest.

SOCIETY OF ARTS.

DECEMBER 7.

HARRY CHESTER, ESQ., IN THE CHAIR.

"On a New Safety Lamp, and on the invention of the Safety Lamp," by Dr. Glover. As the history of the invention of the safety lamp was frequently misunderstood, the author thought it advisable to call attention to the simple facts of the case in the first instance. He said that Dr. Clanny, so far back as the year 1806, conceived the idea of a safe lamp to burn in mines. In the year 1813, a paper by him on the subject was read to the Royal Society, and published in the "Philosophical Transactions." Dr. Clanny's first lamp, although cumbersome, was quite safe. His plan was to insulate the light by means of water, and to supply the flame with air by a bellows. Sir Humphrey Davy, before the production of his wire-gauze lamp, proposed four others, all modifications of that of Dr. Clanny. At length his attention was drawn to the researches of Tennant, "On Flame." Tennant, of Cambridge, had discovered that flame would pass along tubes in a ratio compounded of their breadth and length. The smaller the calibre, the shorter would be the length that flame could traverse. Davy improved upon the idea, and with that happy and sagacious genius which belonged to this wonderful man, came to the conclusion that wire-gauze was, as it were, an abstraction of this principle, and that here we had tubes of the shortest possible length, and narrowest diameter. Hence his invention of the safety lamp. But as the object of these preliminary observations was to do justice to all, it must not be denied that there was indisputable proof that George Stephenson, absurdly called by a biographer of Davy, a *Mr. Stephenson*, had, when a humble miner, ascertained the same fact practically; and it was also quite clear that these two great men knew nothing of each other's inventions. But after the invention of the wire-gauze safety lamp, certain imperfections began gradually to reveal themselves. In the first place, it was found to give so little light that the pitmen seized every opportunity of removing the gauze, finding, in point of fact, that their work could not be done with the imperfect light. And, in the second place, the great fact began to be developed, that this lamp, however secure in a still atmosphere, *was not safe in a current*. An account of the various attempts made to remedy the defects of the Davy, viz., insecurity in a current, and deficiency of light, would fill a volume. As far as the author was aware, the only lamps that had to any extent superseded the Davy were the Clanny and Müsseler lamps. Dr. Clanny found that if the lower part of a lamp were made of thick glass, and the wire-gauze cylinder retained above this, two things arose:—1st, the current of air descended to feed the flame in converging curves, and the gaseous products of combustion ascended in diverging curves; and, 2d, owing to the use of the glass, the gauze, being no longer required to give light, could be made much finer, or even doubled and trebled. The Müsseler lamp differs from the Clanny only in having a chimney in its interior, just above the flame. But there were two objections to the Clanny lamps, viz., the liability of the glass to fracture on being heated, from a drop of water falling upon it in this state, and also its liability to fracture from mechanical causes. To remedy these defects as far as possible, Dr. Glover's lamp had been invented. Instead of the single glass cylinder of the Clanny lamp, a double cylinder was used. The outer cylinder was a quarter of an inch thick, the inner one a good stout glass, a full eighth of an inch thick. The air to feed the flame entered at the top of both, through wire gauze, and passed downward between them, entering the inner cylinder through gauze. The double cylinder, kept packed, as it were, together by the gauze, was thus much stronger than a single one would be, and if either cylinder be broken, the lamp was still a safe lamp. The current between the glasses kept the outer cylinder cool, so that it could always be held in the hand, while a Müsseler or Clanny got soon so hot, that it would burn the flesh. The light was even superior to the Clanny, owing probably to the more perfect combustion, the air entering the inner cylinder at the bottom.

"On British Agriculture, with some account of his own operations at Tiptree Hall Farm," by Mr. J. J. Mechi.—In presenting another balance-sheet, the author stated that he intended chiefly to call attention to the new method of irrigation as practised successfully by him, which involved in its consideration our water supply, sanitary condition, and physical support, and the application of steam to cultivation. The balance-sheet gave a favourable and encouraging result, as the benefit derived this year, in real profit and interest, was nearly £600; and this, notwithstanding the purchase of £700 worth of corn, oil-cake, &c., for the live stock. Nearly the whole difference between this balance-sheet and the former one, arose in the life-stock account. By irrigation he was enabled to double, if not triple, his green and root crops, and thus render them profitable instead of unprofitable.

It was quite clear, that if he could double his stock, he doubled his manure, and thus affected importantly the cereal crops. If he doubled his green and root crops, he would diminish their cost one-half. This was actually the fact, and therein was his present and most agreeable position. Every practical farmer knew that the losing part of his farm was the root crop, in costing him more than the annual repayed, and leaves a heavy charge on the ensuing grain crop. Irrigation changed all this, and permitted each crop to be responsible for its own annual charge, thus rendering them all remunerative. Professor Way, in his recent analysis of grasses in the Royal Agricultural Society's Journal, had revealed the astounding truth, that irrigated grasses contain twenty-five per cent. more meat-making matter than those not irrigated. We know, by our great chemists, that our sewers contain the elements of our food—of, in fact, our very selves—and that to waste them, as we now do, was a cruel robbery on the welfare and happiness of our people. Practical experience had taught Mr. Mechi, that the sewerage was all the better for ample dilution; that the more you flood your cities with limpid streams, rushing from every tainted and poverty-stricken court and alley, the elements of pestilence and suffering, the grateful earth will absorb them in her bosom, and return them to you as treasures of health and strength. When he spoke of liquefied manure, he must be understood as meaning all excrementitious matter, solid or liquid, rendered fluid or semifluid by the action of water, or by decomposition in water—uniting with large quantities of such decomposing matter, a disagreeable and unhealthy effluvia would arise, however small the trap or cover of the tank; but experience had at length taught him, that a jet of waste steam admitted into the tank above the agitated mass of putrefaction, effectually prevented any noisome odour. To irrigate a farm of about 200 acres, you would require—four horse steam-power; fifteen yards per acre of three-inch iron pipe; a circular tank, about thirty feet in diameter, and twenty feet deep; two hundred yards of two-inch gutta percha hose; a gutta percha jet; and a pair of force pumps, capable of discharging 100 gallons per minute. At present prices, all this could be accomplished for about £6 per acre, so that the tenant paying 9s. per acre to his landlord for such an improvement would be a great gainer. While touching on irrigation, it might be useful to consider drainage, with which it had a close connection. Of course, without drainage, natural or artificial, irrigation would be injurious. There could be no doubt as to the necessity for applying sand or peat pots, or other natural and free receivers of water, when surrounded by tenacious clays. Up and down drains would generally do this, but where they did not, lateral branches might be added. Every farmer, with 200 or 300 acres, who had not a steam-engine, had a great lesson to learn, as a good four-horse power steam-engine, worked at 70 lbs. to 90 lbs. to the inch, would tire any sixteen real horses that could be found, its comparative cost being £150 against £600, besides eating nothing, when not at work, occupying less space, and economizing an immense outlay in casualties by disease, cost of attendance, and daily food. The author then alluded to Mr. Romaine's steam-cultivator, and to Mr. Usher's steam-plough, both of which he thought might yet be made sufficiently powerful to work thirty or forty acres, or even a hundred acres a day. The former machine would, if required, deposit the seed and roll the land at one and the same time, and, when not cultivating it, would be available for driving the thrashing machine, millstones, irrigating pumps, chaff and turnip-cutters, cake-breakers, &c., requisite on most improved farms. It was also intended to work a reaper at harvest. The new American thrashing machine was considered to be an implement that would supersede all ours in cost, utility, lightness, durability, and general economy; but, instead of working it by horse power as had been proposed by their Yankee friends, he had erected a small portable steam-engine of 100 horse power to the machine, and proved its advantages over a relay of eight horses.

DECEMBER 21.

HARRY CHESTER, ESQ., IN THE CHAIR.

"On Pettit's Fisheries Guano," by Horace Green. The paper commenced by stating that guano was generally understood to have been introduced to the notice of Europeans by Von Humboldt in 1804. It was brought to England as an object of merchandise in 1839. It had been used in Peru for 100 years and upwards, and the island depositories had been for ages under the management of the State. In 1841, Professor Johnston gave the price of guano as £25 per ton in this country, and not more than £2. 5s. to £3. 10s. on the spot; and having made an analysis, and calculated the price at which the same amount of fertilising matter might be added to the soil from the manufactories of this country (say £9. 10s.), he deduced that the British farmer should not be called upon to pay more than £20 per ton for Peruvian guano. Mr. Philip Pusey also gave the same opinion. Of the excrementitious matter voided by sea birds, a very large proportion was decomposed before the guano of commerce was extracted from its

beds, and more still before its arrival in this country. Proof of the rapid depreciation of guano in keeping, might be found in the analysis of the dung of birds, by M. de Coindet and Sir Humphrey Davy. Coindet found in recent excrement, 8.01 of pure ammonia, and of ammonia in the form of its equivalent of uric acid, 35.20, making a total of 43.81 per cent. Davy found that the soluble matter of the dung of pigeons decreased from 23 per cent. in the recent excrement, to 16 per cent. in that of six months old, and to 8 per cent. after fermentation. It appeared that in five years (1845-50), nearly 650,000 tons of guano had been brought almost round the world for the stimulation of the soils of this country; but it was generally believed that the zenith of supply from Peru was past. From the mean of many analysis of different varieties, it was stated that the amount of ammonia was, in Saldanha Bay, 1.63 per cent.; in Patagonian, 2.55 per cent.; in Cape and Algoa Bay, 2.00 per cent.; and in the New Islands, 1.96 per cent.; but, in phosphate of lime, which was the next most important element, these guanos were richer as they were poorer in ammonia. The mean amount of phosphate of lime was, in Saldanha Bay, 55.40 per cent.; in Patagonian, 44.00 per cent.; in Cape and Algoa Bay, 20.00, per cent.; and in the New Islands, 62.80. The question, however, arose, whether or not large quantities of such manures could be sold at a price which should not exceed the home cost of super-phosphate of lime. Reference was then made to the Guano Substitute Prize of £1000, and the gold medal, which were offered by the Royal Agricultural Society for the discovery of a manure equal in its fertilizing properties to Peruvian guano, and which could be sold at a price not exceeding £5 per ton; and it was contended that, according to the composition of guano, as given by Professor Way, and the known value of these several articles in the markets of commerce, the value of a ton of such material would be upwards of £12, it was not at all probable that any one could dispose of it for £5. The author then proceeded to describe the fisheries guano of Mr. Pettit, and gave the results of several analysis, from which it was deduced that, according to the scale before alluded to, the mean value of the samples tested, was £9. 7s. 7d. per ton. The manufacture of this guano on a large scale would be carried on by a process of the following nature:—A given weight of fishy matter was placed in a large tank, and sulphuric acid of commerce added to the mass. The action of the acid was so powerful as speedily to reduce the organic matter to a soft pulpy consistency, resembling in appearance the fecal matter of birds. This pasty mass being placed in a centrifugal drying machine, and the superabundant moisture forcibly driven off, the partially dry matter was now submitted to a heat not exceeding 212° Fahrenheit, and afterwards pulverised in a suitable manner. In this process, the oily matter of the fish separated itself, and swam upon the surface of the liquid, hence it could be easily separated, and formed an important item in the economy of the manufacturer; since, taking all kinds of fishy matter, we obtained an average of three per cent. of oil, worth £25 per ton, or three-fourths of the whole expense of the raw material. Another process might in some cases be adopted with advantage, especially with cartilaginous fish. As to the supply of the raw material, it was believed, from the testimony of many persons on the coasts, as well as in the evidence in several Blue Books, that an ample supply of refuse fish would be obtained at an average price of £1 per ton, and, taking 60 tons of this weekly, the cost of manufacture and incidental expenses would be £10,043 per annum. From this there would result 93 tons of oil, which, at £25 per ton, would give £2,325, and 1653 tons of guano, at £7 per ton, or £11,571—making together £13,896, as the amount of sales, or a profit of £3,253.

"On Fish Manure as a Substitute for Guano," by J. B. Lawes. He stated that some years ago an inquiry was instituted as to whether the offal and refuse fish of Newfoundland could not be prepared into a manure at a cheaper rate than that already in the market, when it was found that there were difficulties in the way which led to the abandonment of the idea.

JANUARY 18, 1854.

T. WINKWORTH, ESQ., IN THE CHAIR.

"On Stitching Machines," by C. T. Judkins.

JANUARY 25.

HARRY CHESTER, ESQ., IN THE CHAIR.

At this meeting a model was exhibited of Parratt's Patent Tubular Life Raft. This raft is composed of two rows of vulcanized india-rubber tubes, enclosed in canvas cases and nettings, the two rows meeting at their ends, and forming, when extended by means of cross spars, a contrivance which is capable of being rowed like a boat. The tubes are proposed to be always kept inflated, so as to be ready at a moment's notice, and to occupy the interior of a long-boat, or any ordinary boat carried on a ship's davits.

The paper read was, "On Laws relating to Property in Designs and Inventions, and the effect of such Laws on the Arts and Manufactures," by Mr. Thomas Webster. After alluding to the effect and practical operation on the progress of knowledge, and on the advancement of the arts and manufactures, of the recognition and protection of property in intellectual labour, the author proceeded to say that exception had been taken to the term property as applied to these subjects, on the ground that it could only be said to exist in that of which possession could be had, and that possession of the idea being gone when a book, or design, or invention had passed out of the hands of its author, he could no longer have any property therein. Now, the real subject of property in intellectual labour was the right of multiplying copies; and the creations of the mind, whether embodied in a book, a piece of music, a painting, a design, or an invention, resembled, and were in many respects analogous to, each other. The assumption that books add to the intellectual resources of the world, capable of being used the next day, but that an invention, the

subject of a patent, prevented the manufacturer from using not only it, but anything like it, was considered to be fallacious. The objects of the patent laws were believed to be threefold—1. the communication of the secret and its preservation for the public; 2. the extension of the arts and manufactures and trade of the country; and, 3. reward to the author and publisher of such secret, or introducer of such new trade or manufacture. Much of the disappointment experienced by patentees arose from their own ignorance, and it was thought that this would be obviated by a proper system of preliminary examination. So far as the individual inventor was concerned, the patent laws acted as a powerful stimulus on his inventive faculties; and the author contended that our manufacturing superiority could only be maintained by continual progress, and that such progress could only be insured by giving property in the inventions which were to contribute thereto. With regard to the impression, that many of our machines were so far advanced that their farther improvement was so simple and obvious, that any special property in them would only produce embarrassment, it was thought that each machine so improved was, in fact, a new machine, and that the inventor was fully entitled to reap the benefit of his discovery. The stimulus of the patent system in encouraging useful arts, and the introduction of new trades in the realm, was felt at a very early period in the country; and the operation of strikes had had considerable influence on the progress of invention. The self-acting mule, the wool-combing machinery, and the riveting machine, were due entirely to these causes. The testimony of the most intelligent and best judges showed that a very large proportion of inventions proceeded from operatives; and he believed that the artisans of this country would be found in the next century to occupy the position of the Watts and Arkwrights of the last century. For designs, whether for the framing of machinery, the damask manufacture, or calico-printing, the law had hitherto provided most inadequate protection, and he was at a loss to understand the grounds upon which the Copyright of Designs Act assigned different terms of copyright. The legislation on the subject of designs required, in his opinion, entire revision, both as regarded the subject, the term, the payment, and the remedies; and it could hardly be doubted but that all assimilation to the practice of the new patent law would be a great boon to artists and other ingenious men engaged in what has been designated art-manufacture.

Mr. E. B. Denison contended that the patent laws were a bar to improvement—that it was admitted that patentees generally lost money, and in some instances had had to apply to Parliament—that a man who made a trumpery invention, which came into general use, might make a fortune, although he had not extended the bounds of human knowledge. Neither Newton, Oersted, Leibnitz, nor Faraday, had obtained patents for their discoveries. When the Parliamentary Inquiry was made in the year 1829, the average number of patents was 180 a year, whilst in 1851 they had increased to 500 a year. He had looked through the evidence given before those committees, and he found that, in 1829, not a single person had hinted at getting rid of those laws, whilst, in 1851, the independent witnesses were divided in opinion upon the subject.

WEDNESDAY, FEBRUARY 8.

A discussion took place on the "Defects in the Administration of the present Patent Laws." The subject was divided, for convenience of discussion, into four heads:—1st, Cost; 2d, Preliminary Examination; 3d, Tribunal; 4th, Length of Time and Renewal.

Mr. Webster wished to correct an unintentional misstatement in his paper, relative to Mr. Burch's invention. Mr. B. was the sole inventor, and not jointly with any other person. As to cost, he was of opinion that the present sum was practically unobjectionable.

Mr. Denison made some objections as to the order of discussion laid down by the Council.

Mr. Cole thought that inventions should not be taxed, and that the inventor should be called upon to pay no fee beyond that required for the expenses of the office.

Mr. Stansbury agreed with the principles laid down by Mr. Cole, and stated that such was the practice of the American Patent Office.

Mr. C. Varley said the present sum charged was too high.

Mr. Alexander Campbell thought the cost too high, and the term of three years not sufficient in the first instance. It was not long enough to secure the invention being taken up by the public.

Mr. Denison said that, if patents were to exist, he thought that no fee should be exacted beyond that which suffices to cover office expenses. He then spoke of the necessarily heavy costs to which every successful inventor was subject, in trying and establishing its validity. He saw no remedy for this; it was a necessary incident to such rights.

Mr. Campin said that the American Patent Office charged 500 dollars to an Englishman, and 300 dollars to other foreigners, and suggested that these high fees enabled the office to show a flourishing balance.

Mr. Stansbury said that there had been only 200 patents granted to Englishmen and foreigners since its establishment, and the balance, therefore, did not arise from that source. He considered such distinctions bad, and had advised their removal.

Mr. Curtis introduced and gave results of his experience as to difficulties in obtaining a patent for the colonies, under the present law.

Mr. Webster explained that the nature of the conflicting patent laws in the different colonies had induced the Government to determine not to grant any patents for the colonies generally.

Mr. Stansbury spoke of the American system of preliminary examinations, of which he did not altogether approve; too much was attempted.

Mr. Fontaine Moreau said, that after great consideration, France and Belgium had rejected a preliminary examination.

Mr. Cole thought the example of France and Belgium a good one. Every man should be (and he thought under the present system of indices, and publications of specifications at a low rate, every man could be) his own examiner, and would do it better than any Government board could do it for him.

Mr. Campin thought that to extend the examination beyond novelty was going too far.

Mr. Webster thought the American system attempted too much. He considered it the duty of Government to warn parties applying, and then let them take out their patent at their own peril.

Mr. Prosser said that, as a patentee, he protested against any man, however eminent, examining and pronouncing a preliminary opinion on any invention whatever, and cited many instances of well-known men of high standing giving opinions on inventions not warranted by subsequent experience. He thought every man should be his own examiner.

Mr. Curtis agreed with Mr. Prosser.

Mr. Denison thought it was no business of Government to advise people; let each man examine for himself.

Mr. Cole spoke highly of what the Patent Office was now doing as to publication of indices and specifications; under this system a man could readily make his own preliminary examination.

FEBRUARY 15.

HENRY COLE, ESQ., C.B., IN THE CHAIR.

"Ancient and Modern Metal Working and Ornamentation, with some Allusion to the newly-discovered Art of Nature-Printing," by Mr. W. C. Aitken, of Birmingham.—After a few remarks on the subject of ornament on metal-work generally, and on the objections made to certain kinds of ornamentation, in which mechanism had taken the place of hand labour, a description was given of the method adopted for producing a large bronze statue, as well as for small castings, such as statuettes, &c. References were then made to the heaten work of the ancients and medievalists, which was somewhat akin to the modern process of stamping, except that, in the latter, the falling below of the stamp-hammer, on which the die was fastened, took the place of the hand-hammer. A short account was next given of the modern art of electro-metallurgy, which admitted alike the creation of new and the reproduction of old works of art, at a comparatively small cost. Ornamentation, by means of engraving, was considered to be an expensive process; and on this account attempts have been made, from time to time, to supersede it, and also the cheaper substitute of chasing. Attention was then directed to a process which had been recently introduced, the practical application of which was due to Mr. R. T. Sturges, who held the patent jointly with Mr. R. W. Winfield. The fact of a soft material imprinting on a harder one an impress of its form had long been understood. In the early stages of this invention, it was imagined the harder the material out of which the design was made, the better for the purpose. Keeping this their imagined requisite in view, the first ornament unprinted was made out of steel wire, formed into shape, and afterwards tempered; but the result was remarkably indefinite and unsatisfactory. Ordinary thread-lace was then suggested, and tried with success. It was found that it would sustain a pressure of not less than ten tons, and come out from such a pressure comparatively uninjured, leaving its impress even on so soft a substance as Britannia metal. Subsequently, it was found that the same result was produced on copper, on the compound metal brass, on German silver, on iron and tin plate, and on what is generally believed to be the hardest metal, steel. It should be stated that the device, whatever that may be, either in perforated paper, thread-lace, or other media, is placed between two sheets of metal, and the whole is then passed through metal rolls. The author then referred to the art of nature-printing, for which the Austrians had preferred a claim, remarking that the English patent for the ornamentation of metals, which was precisely similar, so far as the means employed, was taken out on the 24th January, 1852; he explained, that some time back he had himself taken impressions of a leaf, a flower, a feather, in Britannia or other metal, from which he had printed direct, except that in some cases he had made a transfer to a lithographic stone, and had multiplied copies by the ordinary process of lithography.

ROYAL INSTITUTION.

The following are the Friday evening arrangements before Easter:—

January 20.—Professor Faraday, D.C.L., F.R.S. On Electric Induction—Associated Cases of Current and Static Effects.

January 27.—Professor Tyndall, Ph. D., F.R.S. On the Vibration and Tones produced by the Contact of Bodies having different Temperatures.

February 3.—W. R. Grove, Esq., Q.C., F.R.S. On the Transmission of Electricity by Flame and Gases.

February 10.—Professor Owen, F.R.S. On the Structure and Homologies of Teeth.

February 17.—John Conolly, M.D., D.C.L. On the Characters of Insanity.

February 24.—Henry Bence Jones, A.M., M.D., F.R.S. On the Acidity, Sweetness, and Strength of different Wines.

March 3.—Rev. Professor Baden Powell, M.A., F.R.S. On certain Paradoxes of Rotatory Motion.

March 10.—Charles Brooke, Esq., F.R.S. On the Construction and Uses of the Modern Compound Microscope.

March 17.—Stephen H. Ward, M.D. On the Growth of Plants in closely Glazed Cases.

March 24.—Edwin Lankester, M.D., F.R.S. On the Structural and Physiological Distinctions supposed to limit the Vegetable and Animal Kingdoms.

March 31.—John Hall Gladstone, Esq., Ph. D., F.R.S. On Chemical Affinity among Substances in Solution.

April 7.—Rev. John Barlow, F.R.S., V. P., and Hon. Sec. On some of the Properties and Applications of Silica.

JANUARY 20, 1854.

THE RIGHT HON. MR. BARON PARKE IN THE CHAIR.

Professor Faraday began the season as usual, this place of honour being now generally conceded to him; and upon his favourite subject, it is no wonder that a very numerous assembly came to hear him descant upon "Electric Induction—Associated Cases of Current and Static Effects." It is very singular to notice how new arrangements of well-known substances and instruments generate new classes of facts; and it is still more remarkable how the scientific observer stands ready on the watch to catch hold of such facts, and make the most of them. The land electric telegraph was one thing. It turns out that the submarine telegraph is another, just as a plain copper wire passing through the air is productive of certain phenomena when subjected to electric influence, while such a wire coated with gutta percha exhibits still more extraordinary phenomena. The lecturer stated that he had, by means of the great machine employed by the Electric Telegraph Company, proved the truthfulness of the view which he had put forth sixteen years ago (Experimental Researches, 1318, &c.), respecting the unusually dependent nature of induction, conduction, and insulation. He had been enabled to experiment with 100 miles of wire. When the wire in the air was experimented upon, not the slightest sign of any of certain effects upon the galvanometer was produced; with the water wire the action was made evident, yet the wire was equally well and better insulated, and, as regarded a constant current, it was an equally good conductor. In consequence of the very accurate manner in which the wire is covered with the gutta percha, a Leyden arrangement is produced upon a grand scale; the copper wire becomes charged statically with that electricity which the pole of the battery connected with it can supply (Davy, Elements of Chemical Philosophy, p. 154); it acts by induction through the gutta percha, producing the opposite state on the surface of the water touching the gutta percha, which forms the outer coating of this curious arrangement. The gutta percha across which the induction occurs is only 0.1 of an inch thick, and the extent of the coating is enormous. The surface of the copper wire is nearly 8,300 square feet, and the surface of the outer coating of water is four times that amount, or 33,000 square feet. Hence the striking character of the results—results which the best ordinary electric machines and Leyden arrangements cannot as yet approach. The phenomena offer a beautiful case of the identity of static and dynamic electricity, the whole power of a considerable battery being made capable of being worked off in separate portions, and measured out in units of static force, and yet be employed afterwards for any or every purpose of voltaic electricity. The Professor then proceeded to further consequences of associated static and dynamic effects, showing by experimental demonstration many very striking, such as a current of electricity flowing on to the end of the wire, whilst there was none flowing in at the beginning—currents flowing out at both extremities of the wire in opposite directions, whilst no current is going into it from any source—a current first entering into the wire, and then returning out of the wire at the same place. When an iron wire of equal extent is experimented with in like manner, no such effects as these are perceived, proving that, in the former case, time is exactly appreciable. All these results as to time depend upon lateral induction. Admitting that such and similar experiments show that conduction through a wire is preceded by the act of induction, then all these singular phenomena are explained. Mr. Wheatstone had, in 1834, measured the velocity of a wave of electricity through a copper wire, and given it as 288,000 miles in a second. Professor Faraday had, in 1838, shown how it was possible for this to be retarded, and now, with 1,500 miles of subterraneous wire, the wave was two seconds in passing from end to end; whilst, with the same length of air wire, the time was almost inappreciable. With these lights, it is interesting to look at the measured velocities of electricity in wires of metal as given by different experimenters:—

	Miles per Second.
Wheatstone, in 1834, with copper wire, made it	288,000
Walker, in America, with telegraph iron wire,	18,780
O'Mitchell, do. do.	28,524
Fizeau and Gonnelle, copper wire,	112,680
Do. iron wire,	62,600
A. B. G. (<i>Athenæum</i> , Jan. 14), copper (Lon. & Bruss. Tel.),	2,700
Do. do. do. (Lon. & Edin. Tel.),	7,600

The Professor remarked, that although these effects are so, the conducting power of the air and water wires are alike for a constant current. Mr. Clarke arranged a Bain's printing telegraph with three pens, so that it gave beautiful illustrations and records of facts like those stated. The pens are iron wires, under which a hand of paper, impregnated with ferro-prussiate of potassa, passes at a regular rate by clockwork, and thus regular lines of prussian-blue are produced whenever a current is transmitted, and the line of the current is recorded.

In the course of the evening, Professor Faraday explained the operation of the Statham fuze, which is of the following nature:—Some copper wire was covered with sulphuretted gutta percha; after some months, it was found that a fibre of sulphuret of copper was formed between the metal and the envelope; and further, that when half the gutta percha was cut away in any place, and then the copper

wire removed for about one-fourth of an inch, so as to remain connected only by the film of sulphuret adhering to the remaining gutta percha, an intensity battery could cause this sulphuret to enter into vivid ignition, and fire gunpowder with the utmost ease. The experiment was shown of firing gunpowder at the end of eight miles of single wire, and Mr. Faraday stated that he had seen it fired through 100 miles of covered wire immersed in a canal, by the use of this fuze.

MONTHLY NOTES.

PROGRESS OF SCREW-PROPULSION.—MARINE MEMORANDA.—The practicability of advantageously substituting screw for paddle steamers, on the mail routes, has now been fully demonstrated in the case of the East India mails. These mails were brought from Calcutta to Suez, by the Peninsular and Oriental Company's screw-steamer *Bengal*, in the short space of 22 days 12 hours, being at the average rate of 11½ knots, or about 13 miles per hour. The *Colombo*, on this side the Isthmus, has been equally fortunate and successful, her average speed on the voyage from Southampton to Alexandria, and back to Malta, having been equal to that of the *Bengal*, notwithstanding the disadvantages incident to a first trip. The overland India and China mail, the Marseilles portion of which was received in London on the 12th January, was delivered in Southampton three days and a half before due, and occupied a shorter period in its transit than any previous mail. It is intended eventually to despatch the *Colombo* to India, where she is to be employed on the Calcutta and Suez route.

Since the above was written, the *Himalaya* has returned from her first voyage, and has more than accomplished what was expected of her; although she has experienced most adverse and unfavourable weather throughout the voyage, she has made the quickest run to and from Alexandria on record. Her best day's run was 347 knots, or close upon 400 statute miles, in the 24 hours, and she made others nearly equal to this. On her return voyage, the *Himalaya* had an opportunity of trying her speed with the paddle-wheel steamer *Euzine*. The latter vessel left Gibraltar 25 hours before the *Himalaya*, which arrived in Southampton at 3 p.m. on the 16th February, and was passed by that ship at 8 the same morning to the westward of Portland, having up to that point beaten her a little more than one-fourth in speed. The *Euzine* is 1200 tons and 400 horse power, while her competitor, the *Himalaya*, has a power of only 700 horses, to 3,560 tons burden. This is very much in favour of the screw, more particularly when it is considered that, with one-third less power, in proportion to tonnage, it is quite possible to obtain a higher rate of speed, and with a consumption of coal of nearly one-half. The original cost of the ship and engines is also proportionately reduced.

Perhaps the most extraordinary run ever made by a sailing ship is that of the *Red Jacket*, lately arrived in Liverpool from New York. A question having been raised as to why, with a fair wind, she should have run 500 miles more than the steamers making the same voyage, Captain Elridge has published the following extract of his log, showing the actual state of the winds, and other particulars. The vessel left New York, Jan. 10, at seven o'clock, a.m. :—

Jan.	Lat.	Lon.	Dist.	Wind.	Course.	Remarks.
11	40° 33'	71° 45'	Miles. 103	S. by E,.....	E. ½ N.,.....	Rainy, unpleasant weather.
12	41 03	63 30	150	Ditto,.....	E. by S.,.....	Rain, hail, and snow.
13	42 19	62 41	265	S. S. E.,.....	E. by N. ½ N.,.....	Ditto.
14	44 25	58 20	232	S. E. by E.,.....	N. E. by E.,.....	Ditto.
15	46 35	54 15	210	Ditto,.....	N. E. ½ E.,.....	Rain.
16	46 13	51 52	106	S. S. E.,.....	E. by S.,.....	Snowy and hailing.
17	45 55	49 03	119	Ditto,.....	E. ½ S.,.....	Ditto.
18	50 39	47 00	300	N. by S.,.....	N. by E. ½ E.,.....	Ditto.
19	51 58	35 55	417	W. by S. ½ S.,.....	E. by N.,.....	Ditto, terrific gale and high sea.
20	50 30	27 00	364	Ditto,.....	E. by S. ½ S.,.....	Ditto, and gale.
21	49 27	18 35	342	Ditto,.....	E. by S.,.....	Ditto, fresh gales.
22	51 07	11 21	300	W. S. W.,.....	E. by N. ½ N.,.....	Snow, strong wind, and heavy squalls.
23	53 27	411	360	South,.....	Up Channel,	Ditto, and squally dirty weather.

Late experiments with Welsh anthracite coal, some of which have been collected by us, have induced the Royal West India Mail Company to take certain collieries in the southern part of Pembrokeshire, in order to obtain an adequate supply of coal for their large ocean steamers. Carmarthenshire, and the adjacent county of Pembroke, possess ample supplies of this species of fuel, which is now very largely being taken into use; and in a short time there cannot be a doubt that it will exclusively be used for sea-going vessels. 1,000 tons were taken out by the *Great Britain* on her present voyage, which, on the report of Captain Mathews, has answered well, steam being quickly raised, the fires burning brightly, and no injurious action on the bars. Large steamers are now continually employed in taking in cargoes at Llanelly for ocean purposes.

The new steamer, *William Norris*, which is warranted to run from New York to Europe in five or six days, is reported to be nearly completed. This vessel is simply flat and sharp, with a good model for running fast in smooth water. She is made unusually strong, by having her timbers strapped diagonally with bars of iron, and by an iron kelson, extending from the keel to the deck, excepting in the central part of the vessel devoted to the engine. This kelson is composed of two parallel sheets of iron, nearly half an inch in thickness, less than a foot apart, and so fashioned and

connected as to form a water-tank. On either side of this kelson are bilge kelsons, formed in the same manner, also reaching up to the deck. It is expected that these unusual supports will give such an amount of strength and solidity to the steamer, as to make her excel all other vessels of similar dimensions.

Captain Ericsson is again trying to talk the scientific and commercial world into hopes of seeing the triumphant success of the caloric engine. He states that there is not the slightest cause for doubt in relation to the enterprise. The new engines are completed, and have been at work several days, their operation proving conclusively that the practical difficulties which attended the first arrangement have all been overcome. The new engines are much reduced in size, while their principle of action is the same as before, with this exception only, that condensed atmospheric air is employed in place of the ordinary atmosphere for producing the motive power. This modification admits of an increase of power, limited only by the capability of retaining the pressure in the machine. Some difficulty has been experienced in this respect, and it is this which has caused some delay recently. The obstacle is, however, nearly removed, and the public will shortly have an opportunity of judging, by practical evidence, of the merits of the caloric ship.

The near prospect of war has induced the Board of Ordnance to institute an inquiry into the capability of converting the mail steamers into vessels of war. In reporting on the vessels belonging to the Peninsular and Oriental and the Royal West India Mail Company, the Committee of Engineers say—"Our opinion is, that the ships of these companies can never be regarded as efficient substitutes for regular men-of-war; and that opinion is based on the following considerations:—1. Their sharp form of bow to promote speed, continued upwards as it is to the height of the port-sills, renders it impossible to point and elevate guns in the line of keel. 2. Their rake of stern would render it dangerous to fire a gun when elevated, more particularly when trained from a fore and aft line. 3. These vessels having been designed entirely for steam propulsion and passenger accommodation, all other purposes have been made subservient to those ends. We find, too, that no attention has been paid to the importance that should be attached to the exposure of the engines, boilers, and steam-chest to shot, which, though in some degree unavoidable in all paddle-wheel steamers, appears to exist in these vessels to a most dangerous extent. After taking a deliberate view of the whole question submitted to us, we have arrived at the conclusion that the ships referred to, provided they could be spared, would serve the purposes of armed troop-ships, and might occasionally be used, in the event of war, in our colonies abroad." The Committee also extended their inquiries to the vessels of the British and North American Company, the Pacific Company, the General Screw Steam-Shipping Company, the Australian Company, the South-Western Company, and the African Company, and found that out of 91 vessels employed as mail contract steam-packets, belonging to these eight Companies, there were only 16 which they could report with any degree of confidence to be available, on an emergency, for auxiliary war purposes (not taking iron vessels into the account); that of the 16, there were eight belonging to the British and North American Company, which, at a cost of about £3000 each, and within a period of not less than a fortnight, might be rendered fit for temporary service as war steamers; that the other eight might, on a great emergency, be employed for defensive purposes, and might be fitted for any pressing service at a cost of from £600 to £800 each, within about a fortnight. The inquiry also touched the merchant service generally, and the steamers in the ports of London, Bristol, and Liverpool were examined; but only seven (five belonging to London, and two to Liverpool) were found fit for conversion into war steamers; while, in consequence of the age of the frames of four of these, it would not be advisable so to convert them. The three others were vessels built for the Germanic Confederation, and recently purchased by the General Steam Navigation Company. The Board of Ordnance, finding that the examination of the merchant steamers of the three principal ports had conclusively proved their unfitness to act as war steamers, and considering that it was not probable that steamers belonging to the remaining ports would furnish any more powerful or better adapted vessels, referred it to the Admiralty to consider whether the inquiry should be any further continued.

TELEGRAPHIC LONGITUDE.—In another portion of the present part of our *Journal* will be found a report of the lecture delivered at the Royal Institution, on the 20th ult., by Professor Faraday, upon electric induction, exhibiting many singular and new effects resulting from the method of insulation adopted in long lines, and especially in submarine operations. The submarine telegraph has lately been employed for the purpose of ascertaining the difference of longitude between the Observatories of Greenwich and Brussels. The problem had already been solved by the land telegraph in determining such difference between the Cambridge and Greenwich, and also between the Edinburgh and Greenwich Observatories. The former was accurately ascertained; but, from some difference in the rate of the chronometers necessarily used, in the other case there was an uncertainty. To solve the new case, M. Quetelet, the Belgian astronomer, entered into the arrangements with right good-will, and provided everything for the utmost accuracy. An unbroken metallic communication was made from the transit-room at Greenwich, through the Dover and Ostend wire, to the transit-room at Brussels. This rendered the use of chronometers unnecessary. The requisite batteries were supplied. The result of the arrangements is, that about 3,000 signals have been observed simultaneously at the two Observatories for the comparison of the two transit clocks. The time occupied by the passage of the galvanic current between the two places has been thus ascertained to be one-tenth of a second. This implies a velocity of 2,700 miles only per second. Professor Faraday explains the reason of this retardation in his lecture already referred to. Great hopes are entertained that the means afforded for thus ascertaining the relative longitudes of different Observatories may be extended to all on the Continent. The immediate result of such a connection will be, as a correspondent, A. B. G., in the *Athenaeum*, suggests,

the possession of the power of bringing into combination the astronomical observations made at different Observatories as if they were made at one. The want of accurate determination of difference of longitude for that purpose has been practically felt by astronomers, and is now particularly so, in several instances. It is not for its immediate, but for its prospective results, that the introduction into Europe of this great instrument of observation is to be hailed with more than ordinary satisfaction.

SOAP AS A VEHICLE OF ART.—Dr. Branson, of Sheffield, who has lately been endeavouring to find an easy substitute for wood engraving, or rather to find out a substance more readily cut than wood, and yet sufficiently firm to allow of a cast being taken from the surface when the design is finished, to be reproduced in type-metal, or by the electrotype process, suggests the employment of soap as a matrix for the die-sinker. In a communication which he makes to the Society of Arts, for the benefit of the public, and without any desire to derive a profit from his ingenuity, he says—"A drawing may be executed with a hard point on a smooth piece of soap almost as readily, as freely, and in as short a time, as an ordinary drawing with a lead pencil. Every touch thus produced is clear, sharp, and well defined. When the drawing is finished, a cast may be taken from the surface in plaster, or, better still, by pressing the soap firmly into heated gutta percha. In gutta percha several impressions may be taken without injuring the soap, so as to admit of 'proofs' being taken and corrections made—a very valuable and practical good quality in soap. It will even bear being pressed into melted sealing-wax without injury."

DUBLIN WINTER GARDEN.—The building lately occupied by the stores sent to the Great Exhibition of Native Arts and Manufactures in the metropolis of Ireland, has been temporarily converted into a winter garden. It is found to be a great attraction; so much so, indeed, that, on many ordinary days, more persons are present than were present at the opening of the building on the first grand occasion. This promises well for our own New Crystal Palace, which is to associate all kinds of gardens with all kinds of exhibitions.

M'LELLAN'S EMIGRANT'S CHURN.—A very convenient form of churn, especially suited to the purposes of the distant traveller or emigrant, has been lately introduced by Mr. Peter M'Lellan, of Bridge of Earn, Perthshire. This churn, as represented in our annexed illustrations, is in the form of a neat barrel, surmounting an open framework stand. Fig. 1 is a longitudinal section of the churn, with the lower portion of its supporting stand broken away. Fig. 2 is a corresponding

in the case of young men engaged as practical miners. The students are to be examined annually, and certificates of progress awarded to those who pass such examinations. The teachers of the Central School are to make periodical tours into the mining districts, under the direction of the governors of the Central School, to inspect the local schools and give lectures. It is also proposed that these schools should be in connection with the "School of Mines" in Jermyn Street, by which all the advantages of communicating with a central source of information would be secured.

COTTON-SEED OIL.—An establishment has lately been started at New Orleans for the manufacture of oil from cotton seed. The oil so produced possesses a soft and pleasant flavour, with all the qualities of olive oil. It burns with great brilliancy, and seems to be peculiarly suitable for lubricating purposes, as it does not dry up, nor become glutinous. As the quantity of the raw material is unlimited, we may expect the manufacture to grow up into something considerable, if the good qualities we have named are solid realities.

INDUSTRIAL COURTS AT THE SYDENHAM EXHIBITION.—To aid the manufacturer in selecting his best position in the Sydenham building, a series of beautifully executed views are being produced in chromo-lithography. The first of these, printed in colours by Messrs. Day & Son, from a drawing by Mr. G. H. Stokes the architect, has just been issued, represents the court set apart for the display of Sheffield cutlery and other wares. These, in themselves, do not give much scope for pictorial display; and the attention is consequently riveted upon the exquisite forms and colours displayed in the construction and ornamentation of the court itself. Perhaps a brief verbal description of its situation may not be unacceptable. The long building runs north and south, crossed by the east and west transepts. The long central aisle or nave is to be occupied by statuary and sculptures, and bordered by a belt of garden and plantation. On the west side of the south nave, nearest to its southerly end, is the Roman or Pompeian villa, extending from the garden back to the outer west wall of the edifice. Adjoining it to the north, and communicating with it by an open archway, is the Sheffield Court, with six entrances, the east one from the nave; the west leading out to the ranges of stalls for mineral manufactures and hardware; the two south entrances communicating with the Pompeian villa; and the two to the north connecting the Sheffield Court with that of Birmingham. The view is taken from the westerly side, showing the eastern side of the court, and beyond the belt of garden, between it and the nave. The entrances we have described are not closed doors, but open archways, across

which are drawn crimson curtains, so as to prevent draughts, yet give easy ingress and egress. Six long counters or tables occupy the floor, and the walls are also decorated with cutlery hung in ornamental figures, as stars, circles, &c. But it is the pictorial effect produced by beautiful forms and rich colours that we seek to notice. The walls seem to be hung with crimson draperies. Above, a richly ornamental Norman arcade, with the dogtooth ornament and appropriate dentelles, &c., separates the court from the garden; and through the open arches are seen the lofty tree-palms, and other luxuriant products of tropical climes, rearing their tall stems, and spreading their fan-like or feathered leaves in rich profusion. The coving above this arcade, with its outer greenish, is composed of large ornamental brackets, or, perhaps, to describe more technically, hammer-beams, but elaborately enriched. Above all is the light blue of the ridged roof of glass; and the harmony of colour is at once felt, though not easily described. The various compartments of the court, occupied by different manufacturers, bear the names of the firms, on labels in the frieze, painted light blue, and which by their colour contribute to the general decorative effect. It is in its commercially valuable character that we wish to bring this undertaking more prominently before our industrialist readers. They must remember

that the collection will form a vast dictionary, wherein a great portion of the world will look for the names of the best makers of whatever is in general and active demand. Each exhibitor pays a moderate rent for the area which he monopolises, and thus, at a trifling annual expense, the textile producer, the steam-engine builder, the glass-maker, and the members of a thousand other trades, can each show the world what they are severally turning out.

A NEW TIMBER TREE.—In the Himalayas, there flourishes a most valuable timber tree, called the *Deodar*, which possesses several qualifications for introduction here as a good workable and serviceable material. It is indigenous to the Himalayas from elevations of 5,000 up to 12,000 feet above the level of the sea, and is of a very hardy nature, growing on the tops of ridges and at the head of gorges, where it is exposed to great vicissitudes of temperature and violent gusts of wind, and flourishing also in the poorest soils. A group in the neighbourhood of Simla measured on an average ten feet in girth, and another group nearly eleven feet, taken at five feet from the ground; while on the northern declivity of the Himalayas they have been measured from twenty to thirty feet in girth at the same height from the soil. It is most excellent in quality, being sufficiently close in texture to be made into articles of furniture, and is of great strength and durability, whilst it requires little or no seasoning, and takes the saw kindly, though it will not split into planks. The *deodar* is said to be preferred by the natives of the Himalayas for the construction of houses, temples, and bridges, and is used not only under cover but for the verandahs, roofs, and external framework of houses, and for the piers of bridges. It is considered almost imperishable, and peculiarly exempt from the attack of worms and insects, its only defect for building purposes arising from its extremely inflammable nature. The *deodar* is, however, owing to its strength and durability, admirably adapted for naval and architectural purposes, and it is said that a boat built of this wood will last from twenty to thirty years. There seems, therefore, no doubt of the *deodar* being fit for all the purposes to

Fig. 1.

Fig. 2.

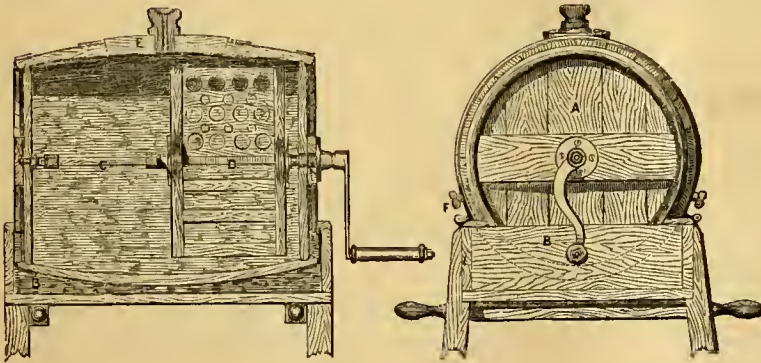

end view, looking on the driving-winch side. The cream receiver is a barrel, A, resting with its side immersed in the hot or cold water chamber, B, forming the top of the stand. The beaters or dashers, C, D, consist of a pair of flat boards, each somewhat less in width than half the barrel's length. One-half of each beater is perforated with round holes, whilst the remainder is barred across. They are entered into the barrel through the elliptical door, E, made just long enough to pass the separate beaters through, and they are disposed at right angles to each other upon a spindle, passing through the axis of the barrel, and turning at one end in a centre formed by a set screw, passed through the barrel end, whilst at the other it rests in a brass collar, screwed on one side. This spindle is driven by a winch in the usual way. The barrel is held in position by embracing hoops of metal, with thumb-fastenings at F, the hoop pieces being hinged, to admit of the cask's removal. Handles are fitted to the stand for the purposes of temporary removal. But when the churn is to be conveyed to a distance, the whole of the moveable details are conveniently disposed inside the barrel, and the barrel itself may then be either conveyed alone, or it may be placed inside the stand. Mr. M'Lellan is also the maker of a somewhat similar churn, which gained a premium at the Highland Society's meeting in August, 1852.

GOVERNMENT SCHOOL OF MINES IN CORNWALL.—A report on a scheme for a Cornish School of Mines has just been drawn up by a committee of gentlemen, appointed at a late county meeting for the purpose. This document recommends that, in the Central School, instruction shall be given in mathematics, natural philosophy and mechanics, applied mechanics, plan drawing, surveying, levelling, machine drawing and construction, mine accounts and mine surveying, chemistry, with special application to metallurgy and assay, mineralogy and geology, working of mines, and preparation of ores. A competent knowledge of these subjects may be acquired by a diligent pupil in two yearly courses, extending over six or eight months in each year. The fee for admission is to be £20, which is to be reduced

which any of the pine tribe are applied in Enrope. So early as 1819, attempts were made to introduce the deodar into this country, but they do not appear to have been successful until 1831, when the Hon. L. Melville brought over some seeds, from which most of the larger deodars in Great Britain, from twenty to twenty-five feet in height, may be traced. The deodar, which used to be one of the dearest, is now one of the cheapest of the recently introduced foreign pine trees, the price having formerly been a guinea a plant, while they can now be had for 6d. each. There are few parts of the British Isles where the deodar will not succeed, as it already flourishes as far north as Forres.

ROE'S SLUICE VALVES FOR HYDRAULIC WORKS.—Mr. Freeman Roe, of the Strand, so well known for his hydraulic mechanism, and in particular for his excellent hydraulic rams for raising water by the agency of mere trickling rivulets, has lately introduced a new form of sluice valve, which we have represented, in elevation and longitudinal section, in the annexed figs. 1 and 2. The general details of construction are obvious from these figures. The special object of the plan is

Fig. 1.

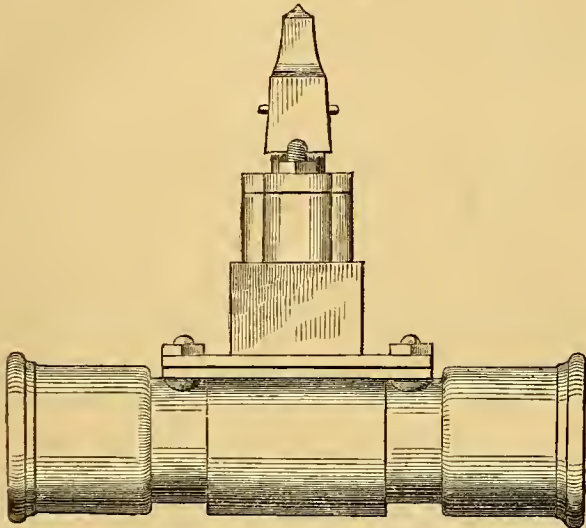

the obtainment of superior facilities for repairs and renewal; for, when such treatment is required, it is quite unnecessary to resort to cutting out of the line of pipe, as is commonly done. By simply removing the bonnet, the whole of the working parts can be taken out, without in any way disturbing the body of the valve.

Fig. 2.

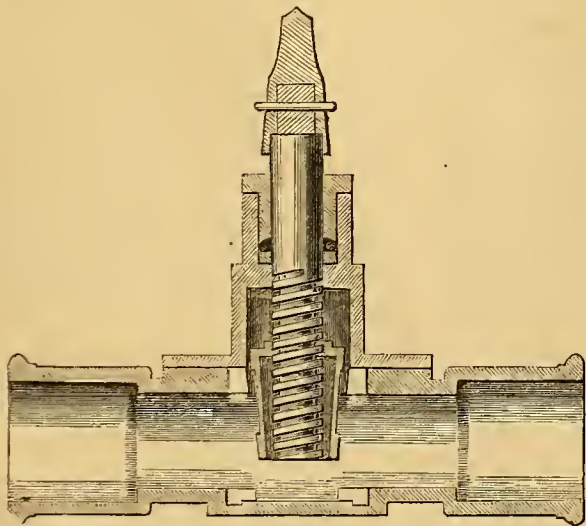

Mr. Roe also makes an ingenious ball-cock, which is valuable from its non-liability to set fast, the ball merely rising off the spindle when the proper fluid supply has been given, thus releasing the valve, which is at once closed by the pressure from below. The valve is of gutta-percha, and the seaming of vulcanized india-rubber.

OUR COAL TREASURES.—The present annual raising of coal in this country amounts to 37,000,000 tons, the value of which, at the pit's mouth, is little less than £10,000,000; at the places of consumption, including expenses of transport and

other charges, probably not less than £20,000,000. The capital employed in the trade exceeds £10,000,000. About 400 iron furnaces of Great Britain consume annually 10,000,000 tons of coal and 7,000,000 tons of ironstone, in order to produce 2,500,000 tons of pig iron, of the value of upwards of £8,000,000. For the supply of the metropolis alone, 3,600,000 tons of coal are required for manufacturing and domestic purposes; our coasting vessels conveyed, in 1850, upwards of 9,360,000 tons to various ports in the united kingdom, and 3,350,000 tons were exported to foreign countries and the British possessions. Add to this, that about 120,000 persons are constantly employed in extracting the coal from the mines, and that in some of the northern counties there are more persons at work under the ground than upon its surface, and some approximate idea may be formed of the importance and extent of this branch of our industry. The extent of the coal areas in the British islands is 12,000 square miles, and the annual produce 37,000,000 tons; of Belgium, 250 miles, annual produce 5,000,000 tons; of France, 2,000 miles, annual produce 4,150,000 tons; of the United States, 113,000 miles, annual produce 4,000,000 tons; of Prussia, 2,200 miles, annual produce 3,500,000 tons; of Spain, 4,000 miles, annual produce 550,000 tons; of British North America, 180,000 miles, annual produce not known.

DRAINAGE OF CITIES.—Getting rid of solid and fluid waste, bears about the same relation to pure water supplies, that foul-air ventilation does to pure-air ventilation. Aerial purity has close connection with drainage. When streets are covered with fetid mud, and untrapped sewers abound on every hand, the atmosphere gets stenchy and irrespirable, people's feet grow chilled, and everything becomes sullied and deteriorated accordingly. Drainage should be constant, efficient, unobtrusive, as may be. A basalt or granite tramway, one or more, with cementitious intervals, instead of the wasteful, inhumane, and dirt-engendering system of broken stones, as usually managed, would at once promote effective sewage and the public health. The unhealthy, stenchy chill, owing to the ceaseless evaporation from surfaces ever moist and ever foul, is greater than what is imagined. The disruption of the causeway, and periodic stirrings-up of sewers and cess-pools, induce stench not less revolting, than productive of discomfort and disease. A close tubular sewage ought everywhere to subsist, with metal or other pipes, of adequate dimensions, strength, inclination, curvature, connection, and depth, with the further aid of hydraulic pressure, to force obstructions. Mr. Allen has proposed semicircular soilage drains with moveable lids, to yield access. In Paris, there are no covered sewers; the consequences may be imagined. Arched, accessible culverts, accommodating gas and sewage pipes, would obviate disintegration of the pavement, and poisoning of the atmosphere. A system of *subvie* has been suggested. Were the road laid on arches, or on cast-iron beams, there would be ample room for every necessary purpose. Even the sewage might be carried through large pipes of cast-iron. It is a practice inconceivably revolting to convert streams like the Thames, the Liffey, the Seine, flowing through great cities, into mere sewage conduits, instead of leaving them as nature intended, a continual solace and endless source of health and purity. Nothing would be easier, due science and skill being pressed into the arrangement, than daily to get rid of all the filth and soil of our cities. Mr. McClean has proposed to carry the London sewage to the Essex flats, while Messrs. Harding and Foster have projected catch-water drains, extending through the Thames tunnel to the Surrey side. Where towns are situated on a declivity, it would be easy, as Mr. Ward has suggested, to drain the sewage into tanks, and then to pump the contents through pipes laid along railways. In well-constructed farm-yards, properly diluted sewage might be distributed from tanks, through hose, amid the fields, producing everywhere, as it has produced in Ayrshire, six and seven crops of Italian rye-grass, two feet long each time. The Rev. Mr. Gore not only points out how towns are to be drained, but how masses of rich, available inodorous manure may be created. Dr. Malcolm has detailed a triple arrangement of street sewers, and subvie galleries. There cannot be a doubt as to the expediency of a system of *subvie*, but it is certain, if we would have regard to health and decency, that foul sewage should be isolated, as in pipes, from all direct connection with the atmosphere. Assuredly, neither outlay nor effort should be spared in applying the sewage of towns in furtherance of agriculture, its only legitimate direction. How much better were it to promote organic growths, than to suffer nauseous waste to pollute the health and homes of men? Animals should be prepared for food in the country, and so avoid great loss, together with the infliction of ammoniacal putrescent waste in towns where such proves in every way hurtful. Crowded churchyards, swarming lodging-houses, open and overflowing sewers, vic with each other in the production of discomfort, degradation, and disease. Refuse may be deodorised by the sulphate of iron, chlorides of soda, lime, or zinc, and very effectively by Rogers' charred turf or peat, rendered so by Violette's heated steam, or otherwise. Common earth, as well as dried peat, though less effective, is also available. Mr. Holland of Manchester, indeed, showed how the foulest matters may be freed from all appreciable fetor, by means of ordinary humus or mould, within the half hour. Irrespective of spiritual soil and bodily suffering, putrid emanations break down the health, and pave the way for an infinity of disease. Owing to imperfect drainage, houses, otherwise of superior pretensions, become next to uninhabitable. Serving women and others, condemned to an underground, cellar life, betray, in their suffering, anxious aspect, the noxious influences to which they are habitually subjected. These evils abound almost everywhere, but seem to have reached their climax in the quarter of St. Saviour, in the city of Lille, as described in Blanqui's *Classes Ouvriers*. It is a succession of small houses, separated by dark, narrow alleys, leading to *courtelles*, or small courts, serving at once as sewers and depositories of filth. The windows and doors of the cellars open on these infected gullies, where a constant stench and humidity reign. Wild, hunchbacked, haggard children, at once unhealthy and deformed, abound. It is only, however, in the cellars that it is possible to judge of the sufferings of those whom age or infirmity does not permit to move abroad!

No population living amid aerial impurities, the partial emanations of cess-pools, drains, and sewers of deposit, can be healthy or free from devastating epidemics. In Philadelphia, a small removable hose, screwed upon a brass cock, concealed under a little iron plate, near the kerbstone, distributes the refreshing element, at will, over the fronts of the houses and pavement of the streets. On the Continent, fountains, at once refreshing and delightful, almost everywhere abound, while here there is nothing, or next to nothing, of the kind.—*Dr. M'Cornac.*

SODA FROM SALT.—Soda has been used, from time immemorial, in the manufacture of soap and glass—two chemical productions which employ and keep in circulation a vast amount of capital. The process of obtaining soda from chloride of sodium, is the one given by Leblanc in the last century, and still adopted, with a few minor improvements, to the present time. This grand process consists in converting the chloride of sodium into a sulphate of soda by means of sulphuric acid, and decomposing the latter salt by means of coal and carbonate of lime, upon the floor of the reverberatory furnace. The duty upon salt checked for a time the full value of this discovery; when it was repealed, its price was reduced to its minimum, and the cost depended upon the sulphuric acid. This manufacture, says Liebig, may be regarded as the foundation of all our modern improvements in the domestic arts; and we may take it as affording an excellent illustration of the dependence of the various branches of human industry and commerce upon each other, and their relation to chemistry. This manufacture became of immense importance during the wars of Napoleon; France, before it was discovered, purchased soda from Spain, at an expenditure of twenty to thirty millions of francs annually. Marseilles possessed for a time the monopoly; the destruction of which, by Napoleon, excited the hostility of the people to his dynasty, who became favourable to the restoration of the Bourbons. France derives at the present time more than twenty millions of francs from this manufacture; other countries quite as much, or even more. The attempts to modify or entirely supersede the process of Leblanc have been incessant, and of the most varied character. One of the latest is that of Mr. Longmaid, for decomposing common salt by means of iron pyrites. It was ascertained that, with a pyrites containing 2 or 3 per cent. of copper, sulphate of soda was economically produced by the ignition of the former with chloride of sodium—the recovery of the copper, converted at the same time into sulphate of copper, contributing to the profit. A great benefit of this process is, that it dispenses with the preparation of sulphuric acid in the leaden chamber. In the manufacture of soda from salt by Leblanc's process, it is first converted into sulphate of soda; the action of the sulphuric acid producing hydrochloric, or muriatic acid, to the extent of one and a half times the amount of the sulphuric acid employed. At first the profit upon the soda was so great, that the muriatic acid was not collected; in fact, it had no commercial value. A profitable application of it was soon discovered: it is a compound of chlorine; and this substance may be obtained from it cheaper than any other source. Chlorine possesses powerful bleaching properties, but was not employed to its full extent until obtained from the residuary muriatic acid, from which it is prepared, by mixing it with peroxide of manganese and sulphuric acid, as a dense, suffocating yellow gas. As it was inconvenient to transport it to distances, either as liquid muriatic acid or gaseous chlorine, it was combined with lime, forming a hypochlorite of that substance, which is well known in commerce as chloride of lime, or bleaching powder. This compound possesses all the potent properties of chlorine, and is used for the purposes of disinfection, bleaching linen and cotton goods, rags for the manufacture of paper, &c. But for this process of bleaching, Great Britain could not have competed with France and Germany in the price of cotton goods. In the old process of bleaching, every piece must be exposed to air and light for several weeks during the summer season, and kept moist by manual labour. Now a single establishment near Glasgow bleaches 1400 pieces of cotton daily throughout the year. The hire of so much land in England, necessary in the old operation, would require an enormous amount of capital, and would greatly increase the cost of bleaching, to pay the interest for the large sum expended. This would not be so much felt in Germany; but the cotton stuffs bleached with chlorine suffer less in the hands of skilful workmen; and in some parts of that country they are adopting it, and find it advantageous.—*H. O. Huskisson.*

THE PAPER MANUFACTURE.—By the old and long-continued vat-mill system, twelve or fourteen different processes were required in the paper manufacture—requiring a period of three weeks to produce the paper, whereas now it is manufactured in almost as many minutes. The paper machine at present in use was invented early in the century by Fourdrinier, a Frenchman; but it did not come into general use here until 1822. Since that period, various important improvements in the manufacture have been introduced, such as the strainer and the sand trap, which clear the pulp of all knots, dust, and extraneous matter. The manufacture of "laid" paper by the machine, which was at first thought impossible, has been in operation for the last six years, and as fine paper is produced by it as formerly could have been turned out by the hand. Waste-cotton from the mills, which formerly was considered quite useless, money being often paid to get rid of it, is now largely used in the production of such paper, particularly newspapers. Straw is another material which has lately been successfully tried. The paper produced from it is pleasant to look upon; it takes a clear impression from types, and, as it does not require to be damped, considerable time is saved in printing upon it. Straw available for the manufacture can be had at about £2 per ton; it is, however, loaded with an Excise duty of £15. In France, the Messrs. Montgolfier have made paper of untanned leather, to be used as cartridges for cannon, for which purpose we in this country use flannel bags. It is said that there is an objection to its use from portions remaining in the piece after discharge, rendering the next charge liable to ignition. Edinburghshire is a considerable seat of the paper manufacture, there being about twenty-four machines in operation in that district. Supposing these machines travel at the average rate of thirty-six feet per minute (some of them

travel at fifty), and supposing that they work fifteen hours a-day, this would be equal to about 147 miles of paper per day, about five feet broad. There are about 360 machines in Great Britain, producing daily about 2160 miles of paper.

REFORM IN THE AMERICAN PATENT LAWS.—The following correspondence, which has passed between Messrs. George M. Knevit & Co. (our correspondents in the United States) and the Commissioner of Patents, will be read with interest by European inventors:—

"New York, January 6, 1854.

"The Hon. Commissioner of Patents,
Washington.

"Whilst the subject of 'Amendment of the Patent Laws' is under consideration, permit us to call your attention to the injustice which is done to European inventors by the high tax which is imposed upon them as patent fee. In many cases, the high fee is prohibitory to an inventor's applying for a patent, and consequently to his obtaining any benefit from his invention. This scarcely accords with the liberality of the American character. The argument, that it would cost an American as much to secure a patent in Europe, is not a sound one, for the European governments charge all applicants alike. If the fees for all foreigners were reduced to 100 dollars, very many more useful inventions would be introduced here. The business of the Patent Office would be increased, but its income would also be considerably increased. If, sir, you will recommend the subject to Congress, you will confer a favour upon, and do justice to all European inventors.

"GEO. M. KNEVITT & CO."

"United States Patent Office,
Washington, January 8, 1854.

"In reply to yours of the 6th inst., I have to state that the subject of the exorbitant fees demanded of foreign applicants has for many months been a subject of consideration with me, and that I shall feel it my duty to recommend some pretty radical changes in this respect.

"Messrs. Geo. M. Knevit & Co.
New York."

This is somewhat promising. But the objectionable feature to which it refers is by no means the most disheartening of those which surround the American system of granting patents. The difficulties thrown in the way of British patentees by the existing process of examination are of much more serious import. We are ourselves constantly subjected to annoyance from this cause. To quote a case in point, we may state that, in the year 1852, we applied for an American patent for a very important invention, and after waiting for a lengthened period, without obtaining the necessary legal right, we were told that some of the claims seemed to clash remotely with a previous invention; still no means were pointed out by which we were to get the matter arranged, and lately we have been finally told, amongst other trifling objections, that the model required by the office did not agree with the description. Somewhere near two years have thus flown by, the time having been completely frittered away, and now the inventor, naturally disgusted with the stupid proceedings, withdraws his claim—subject to the usual penalty of paying 200 dollars for the amusement of the negotiation.

"CONTINUOUS CHECK STRAP" FOR POWER LOOMS.—ACTION FOR INFRINGEMENT.—This was an action brought by the plaintiffs, Cochrane and Crooke, to recover £3. 16s. from Messrs. Croome and Brothers, manufacturers, of Cliepstow Street Mill, Oxford Road, for the use of an invention belonging to the plaintiffs, known as the "Continuous Check Strap," used upon power looms.—Mr. Saunders, for the plaintiffs, said that, about the year 1844, the plaintiff, Crooke, then a hand-loom weaver, had his attention drawn to a defect in the power loom, from the sudden rebounding of the shuttle, whereby the "cop" was often broken in the shuttle, and breakages of the warp were caused. After some time, the idea of a continuous strap, from one picker to the other, passing along in front of the "breast beam," struck him as an effective remedy. Being ill at the time, he called in to his assistance a power-loom weaver named Lancaster, who completed the invention. As they were both poor men, they were unable to raise the necessary funds to make a working model and obtain a patent, then a very expensive process. Under these circumstances they applied to the late Mr. William Eccles, of Blackburn, who at once took out a patent in the joint names of Crooke, Lancaster, and Eccles. Subsequently, it became the property of the present plaintiffs, Cochrane and Crooke. These facts were proved by Crooke and Lancaster, and a great number of witnesses were called to show that prior to 1844, the date of the letters patent, no such strap had been used for such a purpose on the power loom. Mr. Owens, for the defendants, submitted that Crooke was the original inventor, that Lancaster was called in to assist as a mere mechanic, and that Mr. Eccles had nothing to do with the invention beyond the mere act of finding the money to obtain the patent. That being the case, the patent was bad, because a false declaration was set forth, inasmuch as all three had to swear that they were the sole inventors, before the patent was granted in their joint names. Thus the Crown was deceived, and Hindmarsh upon Patents (page 21) laid it down as the law, that where a false declaration was made, the patent obtained under such declaration was void.—The judge took a note of the objection, but ordered the case to be proceeded with.—James Salisbury was then called and examined by Mr. Owens. He was an overlooker of power looms for Messrs. Croome and Brothers. In 1838 he was overlooker at Mr. Smethurst's, of Chorley, when his attention was first directed to the "continuous check strap." He "gaited" 84 looms, made by Mr. Jackson of Bolton, to many of which he applied the check strap, precisely as the one now used by his present employers. In 1844 he worked at the Oxford Road Twist Company's mill, where he also applied the check strap. He was sure that the invention was not new in 1843 and 1844, when Crooke obtained the patent for it. Cross-examined by Mr. Saunders—He did not use it on all the looms he "gaited" at Mr. Smethurst's, because he could not always get sufficient leather

for the purpose. The strap he used in 1838 was exactly the same as the one for which the patent right was now claimed.—Robert Snailsbury, brother to the last witness, swore to the fact that his brother had applied the strap to looms in 1838 or 1839. Several other witnesses were called to prove the use of the check strap before the date of the letters patent.—The judge said he thought the objection to the patent had not been supported by the evidence; that this strap, or some such strap, had been used prior to the date of the patent he believed; but it was not such a use as gave the public a fair and reasonable opportunity of judging of its merits as a whole. Upon the evidence, therefore, there would be judgment for the plaintiffs. The point now to be argued was, whether the patent was rendered void by the alleged false declaration. There were three persons included in the patent—Crooke, Lancaster, and Eccles; and the objection was, that the patent was bad because Crooke alone was the original inventor, and therefore Lancaster and Eccles had no right to share in it.—Mr. Owens then proceeded to argue the point of law, quoting many authorities and text-books upon the subject, the object of which was to show that “the first and true inventor or inventors only” were entitled to the letters patent.—Mr. Saunders replied, recapitulating the evidence, and quoting many authorities and reports of law courts, with a view of establishing the point, that in cases where inventors had called to their assistance other persons in the construction of the machinery, or persons who had assisted in the necessary publication of the invention, as in this case of Eccles and Lancaster, they had as good a right to and a share in the patent as the party who first conceived the idea.—At the close of the argument, the judge said, that in an important case like the present, he would be glad if his judgment could be reviewed by a superior court; but in this case he feared it was not possible. It was one of those points of law which had not before been raised, and therefore the more difficult; but, after having heard the case so fully, and, he might add, so ably argued on both sides, and having himself given great attention to it, he must give his verdict for the plaintiffs with costs.—Verdict accordingly.

ELECTRIC TIME-BALL FOR THE CLYDE.—The practical success of the electric time-ball made for the Calton Hill station at Edinburgh, by Messrs. Maudslay and Field, has been most complete. Sir T. M. Brisbane, who has spent some weeks in Edinburgh, observing and remarking upon the daily descents, has found it so exceedingly accurate and easy of observation, that he has strongly urged the importance of such a system for the Clyde. He proposes that time-balls should be erected at Glasgow and Greenock for the sea-going ships, and being put into electrical communication with the Edinburgh Observatory, they would be dropped by the same galvanic touch which disengages the Calton Hill ball.

PROVISIONAL PROTECTIONS FOR INVENTIONS UNDER THE PATENT LAW AMENDMENT ACT.

☞ When the city or town is not mentioned, London is to be understood.

Recorded August 29.

2004. John H. Johnson, 47 Lincoln's-inn-fields, and Glasgow—Improvements in the preparation and application of gluten.—(Communication from François Durand, Toulouse.)

Recorded October 11.

2230. Charles Rowley, Birmingham—Improvements in ornamental dress fastenings.

Recorded October 25.

2468. Marcus Davis, 5 Clondesley-square, Islington—Improvements in the treatment of fibrous materials other than flax and hemp.—(Communication.)

Recorded November 8.

2595. George Shepherd, 39 King William-street—Certain improvements in the construction of railways.

Recorded November 14.

2628. William Anderson, junior, and Alexander W. Murphy, Glasgow—Improvements in that class of ornamental fabrics usually termed Ayrshire sewed work.

Recorded November 19.

2680. Auguste Castets, Paris—An improved composition for curing diseases of the feet of animals.

Recorded November 22.

2707. Edward Briggs, Castleton Mills, near Rochdale—Improvements in weaving and manufacturing raised pile fabrics, and in machinery employed therein.

2712. Robert Adams, King William-street—Improvements in fire-arms.

Recorded November 28.

2773. James Lord, Farnworth, Lancashire—Improvements in the manufacture of certain articles for ladies' under-clothing, and in fabrics for the same.

Recorded December 5.

2827. Edward Lavender, Deptford—Improvements in apparatus for subjecting substances to the action of heat, for the purpose of carbonizing, calcining, or combining such substances, or for subjecting such substances to the process of distillation.

Recorded December 6.

2932. George Ross and James Inglis, Arbroath—Improvements in looms.

Recorded December 10.

2980. John H. Johnson, 47 Lincoln's-inn-fields, and Glasgow—Improvements in moulding, more particularly applied to toothed wheels.—(Communication from Monsieur De Lonvrie, of St. Mark, France.)

Recorded December 16.

2933. Charles Goodyear, St. John's Wood—Improvements in the treatment and manufacture of india-rubber.—(Partly a communication.)

Recorded December 20.

2964. Archibald Thomson, Glasgow—Improvements in setting out and marking the rivet holes in the plates used in constructing iron ships, boats, boilers, and other vessels.

Recorded December 27.

2993. Edward J. Hughes, Manchester—Improvements in sewing-machines.—(Communication.)

Recorded December 23.

3011. Samuel Barnes, Oldham—A certain improvement or improvements in the construction of looms.

Recorded December 29.

3019. James W. Crossley, Brighouse, Yorkshire—Improvements in the production of surface finish to certain descriptions of fabrics composed of worsted, cotton, or silk, or combinations thereof.

Recorded December 30.

3023. William Pickstone, Radeliffe, Lancashire—Improvements in looms for weaving.

3025. Benjamin Swire, Ashton-under-Lyne—Improvements in machinery or apparatus for making metal tips for shoes and clogs.

3027. James Marlor, Oldham—Certain improvements in a ascending and descending mines and shafts, and in the apparatus connected therewith, by which said improvements the ventilation of mines is increased.

Recorded December 31.

3029. Isaac Holroyd, Sowerby Bridge, Yorkshire—Improvements in apparatus employed in singeing textile fabrics.

3031. Henry V. Physick, 38 North Bank, Regent's-park—Improvements in electric telegraphs and apparatus connected therewith.

3033. John Pym, Pimlico—Improvements in machinery for grinding auriferous and other ores, and separating the metal therefrom.

3035. Alfred Trueman, Swansea, and Isham Baggs, London—Improvements in grinding, amalgamating, and washing quartz and other matters containing gold.

3037. Joseph Holbrey, Bradford—Improved machinery for combing wool and other fibrous materials.

3039. Julian Bernard, 15 Regent-street—Improvements in stitching and ornamenting various materials, and in machinery and apparatus connected therewith.

3041. Adolphus Oppenheimer, Manchester—Certain improvements in the manufacture of silk velvet and other such piled goods or fabrics.

3043. Pierre Sonntag, Paris, and 4 South-street, Finsbury—Improved apparatus for measuring and fitting garments of persons.

3045. Stanislaus T. M. Sorel, Paris, and 4 South-street, Finsbury—Certain improved compositions, to be employed as substitutes for caoutchouc, gutta percha, and certain fatty bodies.

Recorded January 2.

1. Charles H. Collette, 57 Lincoln's-inn-fields—Improvements in the manufacture of sugar.—(Communication.)

3. Alfred Dawson, 14 Barnes-place, Mile-end-road—Invention of converting small coal or coal dust, or small coal and coke, into blocks of fuel.

5. Pierre A. Montel, Paris—Certain improvements in stopping the trains on railways.

7. Peter Armand Le Comte de Fontaine Moreau, 4 South-street, Finsbury, and Paris—Certain improvements in water wheels.—(Communication.)

Recorded January 3.

9. Joseph Madelcy, Walsall, Staffordshire—Improvement or improvements in the manufacture of certain kinds of tubes, and in nuts for and heads of screws.

11. James Stovold, Barnes, Surrey—Improvements in machinery or apparatus for sifting and washing gravel and other similar substances.

13. Edward J. Wilson, 477 Oxford-street—Improved method of making portfolios, music books, brief cases, and pocket books.

15. John L. Grylls, 3 Murton-street, Sunderland—Improvement in whelps for the barrels of capstans, windlasses, and other machinery.

Recorded January 4.

19. David Hulett, High Holborn—Improvements in gas regulators for regulating the supply of gas to the burner.—(Partly a communication.)

Recorded January 5.

21. Joseph Liddard, Deptford—Improvements in the construction of furnaces with a view to the prevention of smoke.

22. David Schischkar, of the firm of James Ackroyd and Son, Halifax, and Frederick C. Calvert, Manchester—Improvements in dyeing and printing textile fabrics and yarns.

23. David B. White, Newcastle-upon-Tyne—Improvements in the manufacture of waterproof fabrics, and of waterproof bags and other like articles.

24. John H. Johnson, 47 Lincoln's-inn-fields, and Glasgow—Improvements in ventilating carriages and buildings, part or parts of such improvements being applicable to the obtaining of motive power.—(Communication from John Chilcott and George Palmer, Brooklyn, New York.)

25. William Rigby, Glasgow—Improvements in steam hammers and pile-driving machinery.

26. Leon J. Pomme, Paris—Improvements in reducing the friction of axles and axle-trees of carriages.

27. John Mason, Rochdale, and Leonard Kaberry, same place—Improvements in machinery or apparatus for preparing cotton, wool, and other fibrous materials for spinning.

28. Alfred V. Newton, 66 Chancery-lane—Improved machinery for crushing or grinding and washing and amalgamating quartz rock and other substances.—(Communication.)

Recorded January 6.

29. Isaac Pearse, Cawsand, Cornwall—Improvements in means for navigating ships or other vessels.

30. Henry H. Edwards, Ludgate-hill—Certain improvements in peat and vegetable matters for the purpose of fuel, as well as in the extraction of other useful products therefrom.—(Partly a communication.)

31. Robert Tate, Glasgow—Improvements in the manufacture or production of ornamental fabrics.

32. John Radeliffe, Stockport—Certain improvements in power looms for weaving.

33. John Healey, Bolton-le-Moors—Improvements in spinning machines known as mules, and in machines of similar character.—(Communication from Adolphe Peynaud and Edmund Peynaud, Charleville près Fleury sur Andelle, France.)

34. Moses Poole, Avenue-road, Regent's-park—Improvements in the manufacture of dextrine, glucose, and alcohol, and in employing the products of such manufacture.—(Communication.)

35. John D. M. Stirling, Larches, near Birmingham—Improvements in the manufacture of iron.

36. Alfred V. Newton, 66 Chancery-lane—Improvements in the construction of motive power engines; part of which improvements is also applicable to the packing of pistons generally.—(Communication.)

Recorded January 7.

37. William Aspden, Blackburn, Lancashire—Certain improvements in looms for weaving.

38. William E. Newton, 66 Chancery-lane—Improved machinery for dyeing, washing, and bleaching fabrics.—(Communication.)

39. Anthony Bernhard Baron Von Rathen, Wells-street—Improvements in chimneys and flues of houses, and in stoves to be employed therewith, whereby better draft will be obtained, consumption of fuel will be diminished, smoke, fog, and night damp will be prevented from entering apartments, more warmth will be thrown out, and whereby fire in the chimney can be readily extinguished.
40. Henry S. Edwards, Paris—Improvements in preparing textile fabrics or materials for the purpose of their better retaining colours applied to them.—(Communication.)
41. John H. Johnson, 47 Lincoln's-inn-fields, and Glasgow—Improvements in machinery or apparatus for effecting agricultural operations, and in communicating power thereto, parts of the said improvements being applicable to the obtaining of motive power for general purposes.—(Communication.)
42. Nicholas M. Caralli, Glasgow—Improvements in the manufacture or production of ornamental fabrics.
43. John G. Taylor, Glasgow—Improvements in writing apparatus.
- Recorded January 9.*
45. Benjamin Burleigh, Great Northern Railway, King's Cross—Improvements in railway switches and chairs.
46. Zachariah Pettitt, Fordham, near Colchester—Improvements in thrashing machines.
47. Richard A. Tilghman, Philadelphia, U.S.—Improvements in treating fatty and oily matters, chiefly applicable to the manufacture of soap, candles, and glycerine.
48. Richard Husband, Manchester—Certain improvements in the method of ventilating hats or other coverings for the head.
49. William Garforth and James Garforth, Dukinfield, Chester—Certain improvements in mechanism or apparatus for retarding or stopping the motion of locomotive engines, and other railway carriages.
50. Richard Howson, Manchester—Certain improvements in screw propellers.
51. William Taylor, How-wood, Renfrew—Improvements in furnaces and fire-places, and in the prevention of smoke.
- Recorded January 10.*
52. Edward Tyer, 3 Rhodes-terrace, Queen's-road, Dalston—Improvements in giving signals on railways by electricity, and in instruments and apparatus connected therewith.
53. William Brown, Bradford—Improvements in preparing to be spun wool and other fibrous material.
54. Antoine M. E. B. E. Ducros and Ossian Verdean, Paris, and 16 Castle-street, Holborn—Certain improved compounds to be used in dyeing.
55. The Rev. William R. Bowditch, Wakefield—Improvements in economizing fuel, and in the more economical production of light and heat.
56. Rev. William R. Bowditch, Wakefield—Improvements in the purification of gas, and in the application of the materials employed therein.
57. Elmer Townsend, Boston, U.S.—Improvements in machinery for sewing cloth, leather, or other material.—(Communication from William Butterfield and Edgar M. Stevens, Boston.)
58. Alexander Mitchell, Belfast—Improvements in propelling vessels.
59. John R. Engledue, Southampton—Improvements in furnaces.
60. Adolphe Drevelle, Halifax—Invention of a new combing machine suitable for any textile or fibrous matter.—(Communication from Augustine Morel, Roubaix, France.)
61. William L. Tizard, Aldgate—Invention of machinery for stamping, crushing, washing, and amalgamating gold and other ores.
- Recorded January 11.*
62. Ambrose A. Masson, Paris—Improvements in the manufacture of thread or wire to be used for making gold or silver lace.
63. Joseph J. W. Watson, Old Kent-road—Improvements in signalling.
64. Henry Bennettsmith, St. Sepulchre's—Invention of a machine for mowing or reaping all kinds of corn, grass, clovers, or any other field growth, and lawns.
65. Daniel Semple, 1st Bombay European Regiment Fusiliers, Adeu, South Arabia—An improved guide for the finger boards of musical stringed instruments.
66. William Watt, Glasgow—Certain improvements in the application of heat to drying purposes.
67. Felix L. Banwens, Pimlico—Improvements in treating fatty matters previous to their being employed in the manufacture of candles.
68. Richard A. Brooman, 166 Fleet-street—Improvements in extracting gold from the ore.—(Communication.)
69. Ralph Lister, Scotswood, Northumberland—Improvements in distilling apparatus.
70. Marcel Veitillart, Le Mans, France—Improvements in drying woven fabrics, yarns, and other goods.
71. Henry B. Lecson, Greenwich—Improvements in gas-burners.
72. Felix Tussaud, Paris, and 16 Castle-street, Holborn—Invention of a universal pump-press, with continuous action, called "Continuous producer."
73. Antoine Ponçon, Marseilles, France, and 16 Castle-street, Holborn—Invention for obtaining a motive power.
- Recorded January 12.*
74. John W. Wrey, 16 Upper Berkeley-street, West—A new and improved method of transmitting motion.
75. Thomas Waller, Ratcliff—Improvements in register stoves, and other stoves or fire-places.
76. Thomas E. Moore, St. Mary-le-bone—Improvements in apparatus to be used for extinguishing fires.
77. John F. Boake, Dublin—Improvements in and applicable to certain lamps or lanterns, so that either candles or oil may be used therein with facility.
78. John W. Partridge, Birmingham—Certain improvements in the manufacture of soap.
79. John Bethell, 8 Parliament-street—Improvements in manufacturing coke.
80. Leon J. Anger, Paris—Improvements in the manufacture of metallic tubing.
81. Thomas F. Henley, Cambridge-street, Pimlico—Improvements in the preparation of certain colouring materials.
82. Auguste E. L. Bellford, 16 Castle-street, Holborn—Improvement in the manufacture of glass.—(Communication.)
83. Samuel Wilkes, Wolverhampton—Improvements in the construction of chairs and rails for railways.
84. John H. Johnson, 47 Lincoln's-inn-fields, and Glasgow—Improvements in the preparation of glycerine, and in its application.—(Communication from Victor Courbolay, Paris.)
85. Robert Maclaren, Glasgow—Improvements in moulding or shaping metals.
- Recorded January 13.*
87. William Eassie, Gloucester—Improvements in trucks used on railways.
88. Arthur Parsey, 3 Crescent-place, Burton-crescent, St. Pancras—Improvements in machinery for obtaining and applying motive power by means of compressed air and other fluids.
89. Patrick O'Malley, Dublin—Invention for the manufacture of a new drink or beverage from certain vegetable and other substances, and the conversion thereof into vinegar.
90. Thomas B. Foulkes, Chester—Improvements in the manufacture of self-adjusting gloves.
91. John Wilkinson, Manchester—Improvements in the manufacture of dies for producing printing surfaces for calico-printers, applicable also to embossing.
- Recorded January 14.*
92. James Newman, Birmingham, and Henry Jenkins, same place—Improvements in the manufacture of spoons, table forks, and other articles.
93. James Bird, St. Martin's lane—Improvements in taps and cocks.
94. Julius Jeffreys, 37 Carlton Villas, Maida Vale—Improvements in the manufacture of mineral charcoal and coke, and in adapting open grates for the combustion of them.
95. Arthur Dobson, Bolton-le-Moors, Lancaster—Improvements in looms for weaving.
- Recorded January 16.*
96. Charles F. Stansbury, 17 Cornhill—Improved method of propelling machinery.—(Communication from Bernard Hughes, Rochester, U.S.)
97. William Crosskill, Beverley, York—Improvements in construction of portable railways.
98. James Newall, Bury, Lancaster—Improvements in machinery or apparatus for stopping or retarding the progress of railway and other carriages, and in the mode or method of connecting two or more carriages with the said apparatus together.
99. Philip Grant, Manchester—Improved roller used in the processes of letterpress, copperplate, and lithographic printing.
100. Peter Blaker, Crayford, Kent, and William Wood, 126 Chancery lane—A machine for crushing coal and the refuse arising from the combustion of coal used for brick-making and other purposes.
101. George F. Wilson, Belmont, Vauxhall—Improvement in the manufacture of candles and night-lights.
102. Penrose G. Julian, 71 Bath-street, Birmingham—Improvements in communicating signals to engineers, guards, and others in a moving railway train.
103. Joseph Spires, Lower Drummond-street, Euston-square—Improvements applicable to boots and shoes.
- Recorded January 17.*
106. William Brown, Camberwell—Improvements in printing machinery.
107. William Crosskill, Beverley, Yorkshire—Improvement in the construction of carriage wheels to run on railways and ordinary roads.
108. Edward Highton, Regent's-park—Improvements in suspending the wires of electric telegraphs.
109. Henry Holland, Birmingham—Certain improvements in the construction of parts of umbrellas and parasols.
110. Robert Maclaren, Glasgow—Improvements in moulding or shaping metals.
111. Henry Corlett, Summerhill, Dublin—Improvements in springs for railway and other carriages and vehicles.
112. Karl Weber, Reckberg, Württemberg—Improvements in the manufacture of boots and shoes.
113. Bevan G. Sloper, London—Improvements in machinery or apparatus for separating gold from earthy matters.
- Recorded January 18.*
114. William B. Haigh, Oldham, Lancaster—Improvements in machinery for tenoning, mortising, slotting, cutting, or shaping wood or metal.
115. Edward Lord, Todmorden, Yorkshire—Certain improvements in looms for weaving.
117. Charles S. Cahill, Greenwich, and Annadown, Galway—Improvements in submarine, subterranean, and other electric and magnetic telegraphs, and in insulating, laying down, joining, and covering the same.
118. William Batten, 74 Westbourne-street, Pimlico—Improvement in the construction of a sink, drain, or gully trap, named the self-acting effluvia trap, for the more effectual conveyance of all liquids or admixtures in passing into drains, sewers, cesspools, or other receptacles, and the better prevention and exclusion of all vapours, effluvia, or gases arising therefrom.
119. Walter Greenshields, Edinburgh—Improvements in chenille fabrics.
120. William Thomas, Cheapside—Improvements in stays.
121. Edmund Sharpe, Swadlowcote Pottery, near Burton-on-Trent—Improvements in the apparatus used for sifting clay.
122. Charles Howard, 4 Trafalgar-terrace, Hoxton—Improvements in the manufacture of iron.
125. Jean P. Bourquin, Newman-street—Improvements in or applicable to troughs or vessels for holding liquid substances required in the art of photography.
- Recorded January 19.*
126. George H. Bursill, Ranelagh Works, Pimlico—Improvements in operating upon metalliferous ores and other minerals, and upon "slags" and "sweep," in order to facilitate the separation and recovery of the metals and other products; also in machinery or apparatus for effecting such improvements, which is in part applicable to other purposes.
128. Alexander Delgaty, Florence-road, Deptford—A new construction of rotatory engines or pumps.
129. John Norton, Cork—Improvements in effecting communication between the different parts of railway trains.
130. Thomas Webb, Platts Glass Works, Stourbridge—Improved apparatus applicable to the annealing of glass and the firing of pottery ware.
131. Heloise Guyon, Paris—Improvements in the manufacture of bread.
132. Henry Brownett, Liverpool—Invention of treating scrap and waste iron so as to render the same more readily available in the manufacture of iron.
133. Francis Parkes, Sutton Coldfield, Warwickshire—Invention of a mode or method of fixing tools and implements in helves or handles.
134. Jeremiah Hunt, State of Massachusetts, U.S.—Improvements in machinery for sewing cloth or other material.—(Communication from Christopher Hodgkinson, of the aforesaid state.)
135. Charles W. R. Rickard, 5 Great Charlotte-street, Blackfriars-road—Improvements in cocks and taps.
- Recorded January 20.*
136. Henry Dircks, 32 Moorgate street—Improvements in safety apparatus applicable to certain boilers and stills.
137. Henry B. Condy, Battersea—Improvements in the manufacture of sulphate of soda, sulphate of potash, and other sulphates, and in the manufacture and employment of muriatic acid.
138. Edward Aitchison, Lieutenant Royal Navy, 14 Manor-street, Cheyne-walk, Chelsea—Improvements in apparatus for fixing, removing, and plugging tubes of tubular steam boilers.
139. Auguste E. L. Bellford, 16 Castle-street, Holborn—Certain improvements in cutting cloth and other fabrics and materials suitable for garments and furniture.—(Communication.)
140. Oliver R. Chase, Boston, U.S.—Invention of pulverizing machinery.

141. James J. Field, Charles-terrace—Improvements applicable to guns, cannon, or ordnance, rifles, and other similar implements of war or the chase, for more accurately aiming at the object to be struck by projectiles.
142. Robert A. Smith, Manchester, and Alexander M'Dougall, same place—Improvements in treating, deodorizing, and disinfecting sewage and other offensive matter, which said improvements are also applicable to deodorizing and disinfecting in general.
143. John H. Johnson, 47 Lincoln's-inn-fields, and Glasgow—Improvements in the manufacture of stays or corsets.—(Communication from Adolphe G. Gernes, Paris.)

Recorded January 21.

144. Richard Roberts, Manchester—Certain improvements in machinery for cutting paper, pasteboard, leather, cloth, and other materials.
146. Marie L. L. Beauloux, Paris—Invention of a candlestick, working by machinery, so as to keep the candle always at the same height in a tube; with a shade of a peculiar construction, so as to augment greatly the quantity of light.
148. George Grace and Thomas F. Jones, Birmingham—Improvements in boots and shoes, as also boot and shoe socks or inner soles, whereby the same are rendered waterproof.
149. John Westerton, Earl's-court-road, Brompton—An improvement in the manufacture of night-light boxes or cases.
150. Cyprien M. T. du Motay, 24 Rue Fontaine St. George, Paris—Improvements in the manufacture of oil from rosin.
151. Herman E. Falk, Gateacre-house, Liverpool—Improvements in preparing or manufacturing salt.
152. Thomas B. Venables, Burslem—Certain improvements in the manufacture of earthenware.
153. Peter Spence, Pendleton, near Manchester—Improvements in manufacturing the prussiate of potash and soda.
154. Daniel Warren, Exmouth—Improvements in raising, pumping, and forcing water.
155. Charles J. Edwards, Great Sutton-street—Improvements in the manufacture of bands for driving machinery.

Recorded January 23.

156. Andrew Shanks, 6 Robert-street, Adelphi—Certain improvements in machinery for punching and shearing metals.
157. Charles C. Armstrong and William Pursall, Birmingham—A new or improved percussion cap.
158. William Darling, Edinburgh—Improvements in sewing machines.—(Communication.)
160. Thomas Robinson, 5 Farrington-street—Improvements in apparatus for filtering volatile liquids.
161. Matthew A. Muir, Glasgow—Improvements in weaving.
162. John Lockhart, jun., Paisley—Improvements in the manufacture of bobbins.
163. John G. Taylor, Glasgow—Improvements in treating the fleeces or natural coverings of sheep and other animals when on the animals.
164. John G. Taylor, Glasgow—Improvements in lamps, and in substances to be burned therein.
165. Henry Seebohm Esholt, near Leeds—Improvements in combing wool, goats' hair, alpaca, cotton, and other fibrous material.
166. John Getty, Liverpool—Improvements in the manufacture of tubular bridges; part of which improvements is applicable also to the preparation of plates for covering iron ships, for constructing boilers, and for other analogous uses.
167. John Westlake, Totnes—Invention for pulverising, washing, separating, amalgamating, and otherwise treating ores, gossans, earths, and rocks, so as to better to obtain and extract therefrom the gold and other metals and minerals which may be contained therein.
168. Auguste E. L. Bellford, 16 Castle-street, Holborn—Improvements in machinery for bending metal, and producing forms thereon by pressure.—(Communication.)
169. Jean M. J. L. Bouvet, 16 Castle-street, Holborn, and Paris—Certain improvements in kneading machines.
171. Richard A. Brooman, 166 Fleet-street—Improvements in machinery for sawing stone and marble.—(Communication.)
172. Richard A. Brooman, 166 Fleet-street—Improvements in extracting the copper from the ore.—(Communication.)
173. Adolphus T. Wagner, Berlin—Invention of a psychograph, or apparatus for indicating persons' thoughts by the agency of nervous electricity.

Recorded January 24.

174. Sir Adderley Sleigh, 1 Weymouth-street, Portland-place—Invention of creating a continual self-acting, self-sustaining new motive power, applicable to every purpose requiring speed, motion, and power, together or separately.
175. George Williams, 16 Cannon-street, St. George-in-the-East—Improvements in the construction of water-closets.
176. Jean B. Moirier, La Villette, Paris, and 4 South-street, Finsbury—Invention of a new chemical process for the production of sulphates of soda, potassa, and alumina of nitrates of soda and potassa, of soap, and of hydrochloric, sulphuric, azaric, morganic, and elaidic acids.
177. Jean L. Schlossmacher, Paris—An improved support of lamps.
178. John Ridgway, Cauldon-place, Staffordshire—Certain improvements in the method of generating and applying heat to kilns, ovens, and furnaces for manufacturing purposes.
179. William I. Ellis, Salford—Certain improvements in turntables to be employed on or in connection with railways.
180. William Massey, Hemer-terrace, near Liverpool—Improvements in artificial teeth and gums.
181. John Bapty, Leeds—Certain improvements in machinery for preparing to be spun wool and other fibrous substances when mixed with wool.
182. Samuel C. Lister, Manningham, Bradford—Improvements in combing wool, cotton, and other fibrous materials.
183. John Bird, Kingswinford, near Dudley—Improvements in kilns for burning bricks and other articles.

Recorded January 25.

184. Joseph A. Mingaud, St. Pons, France—Certain improvements in producing ornamental surfaces on velvet or other hairy cloths or fabrics.
185. Edward B. Walmsley, Middle Mall, Haaromsmith—Improvements in utensils, implements, and apparatus for the purposes of lighting, heating, and cooking.
186. William E. Newton, 66 Chancery-lane—An improvement in violins and other similar stringed musical instruments.—(Communication.)
188. William H. Thornthwaite, Newgate-street—An improvement in the manufacture of sulphuric acid.
189. Richard A. Brooman, 166 Fleet-street—Invention of a new and improved fluid for illuminating purposes.—(Communication.)
190. Archibald L. Reid, Glasgow—Improvements in printing textile fabrics and other surfaces.
191. James Anderson, Auchnagie, Perthshire—Improvements in obtaining motive power.

Recorded January 26.

192. Thomas Wicksteed, Leicester—Improvements in the manufacture of sewage manure.
193. Thomas Wicksteed, Leicester—Improvements in the manufacture of sewage manure.
194. Thomas Wicksteed, Leicester—Improvements in the manufacture of sewage manure, and in apparatus for that purpose.
195. Francis M. Blyth, Norwich—Improvements in the mode of heating water for steam boilers.
196. Charles Reeves, jun., and William Wells, Birmingham—An improvement or improvements in casting metals.
197. Sydney Smith, Ilyson Green Works, near Nottingham—Improvements in valves or apparatus for regulating the passage and supply of fluids.
198. Samuel S. Stallard, York-street, Leicester—Improvements in the manufacture of knit fabrics.
199. George Firmin, Bath—Improvements in anchors.

Recorded January 27.

200. François F. Robart, Sotteville les Rouen, France—Improvements in the preparation of a certain substance for clarifying liquids.
201. Patrick M. Crane, 18 Canonbury Villas, New North-road, Islington—Improvement in the manufacture of iron.
202. Alphonse Cajetan de Simencourt, Paris, and 4 South-street, Finsbury—Improvements in composing and distributing type.
203. William Church, Birmingham—An improvement or improvements in ordnance.
204. Henry Fendall, Hoxton, near London—Improvements in machinery and apparatus for crushing, washing, and amalgamating auriferous quartz and other ores.
205. Thomas Thurbly, Guildford-street East, Spafields—Improvements in the means of effecting instant communication between distant points of railway trains.
206. William Palmer, Brighton—Improvements in the manufacture of materials for and in constructing houses and other buildings.
207. William Partington, Boltou-le-Moors, Lancashire—An improved construction of safety valve for steam-engines.
208. Joseph Atkinson, Richmond-grove—Improvements in thrashing machinery.

Recorded January 28.

209. Jules J. L. Fournier, Montpellier, France—An improved mode of obtaining alcohol.
210. John Grist, New North-road, Islington—An improved break for railway and other carriages.
211. Mead T. Raymond, 25 Clement's-lane, Lombard-street—Improvements in apparatus for retarding and stopping trains of carriages on railways.
212. Josiab L. Clark, 2 Chester Villas, Islington—Improvements in apparatus for conveying letters or parcels between places by the pressure of air and vacuum.
213. Wellington Williams, Cheapside—Invention of a method of and apparatus for heating the beaters of box irons, and other like purposes.
214. David Chadwick, Salford, and George Hanson, Manchester—Improvements in meters for measuring water or other liquids, and vapours or gas.
215. Donald Bethune, Toronto, Canada West—Improvements in the construction of vessels propelled by steam or other motive power.
216. William G. Taylor, Norfolk-terrace, Westbourne-grove—Improvements in certain parts of machines employed for preparing and spinning cotton, wool, hair, silk, flax, and other fibrous substances or materials.
217. William Woolford, Bowling New Dye Works, Bradford—Improvements in pressing and watering moreens and other fabrics.
218. William Redgrave and Thomas Redgrave, 23 Bow-street, Covent-garden—Invention of new railway signal lights, to be called "Redgrave's patent railway signal light."

Recorded January 30.

219. Peter A. Le Compte de Fontaine Moreau, 4 South-street, Finsbury, and Paris—Improved means of preventing accidents on railways.—(Communication.)
220. Peter Armand le Comte de Fontaine Moreau, Paris, and 4 South-street, Finsbury—Certain arrangements for preventing accidents on railways.—(Communication.)
221. Henry J. Iffie, Birmingham, and Nebemiah Brough, same place—Improvements in the manufacture of buttons, and in attaching them to articles of wearing apparel.
222. William Phillips, Birmingham—Improvements in the manufacture of coffins.
223. William Hodgson, Wakefield—Improvements in machinery for the manufacture of looped fabrics.
224. Benjamin O'Neale Stratford, Earl of Aldborough, Wicklow—Improvements in aerial navigation.
225. Joseph R. Cooper, Birmingham—Improvements in preparing or constructing and dressing rolls for rolling gun barrels, tubes, and bars.
226. Richard Garrett, Leiston Works, near Saxmundham—Improvements in thrashing-machines.
227. John Kershaw, Dublin—Improvements in steam-engines.
228. John H. Johnson, 47 Lincoln's-inn-fields, and Glasgow—Improvements in the manufacture or production of gas, and in the application of the materials employed therein.—(Communication.)
229. Robert Chapman, Eaton—Invention of an apparatus for regulating the feed to millstones.

Recorded January 31.

230. Thomas Cox, Wolverhampton—An improvement or improvements in buttons, and in attaching the same to articles of dress.
231. Arnold M. Fatio and François Verdeil, Paris—Improvements in preserving animal and vegetable substances.
232. Edward W. K. Turner, 31 Præd-street, Paddington—Invention of treating gold and other ore.
233. Thomas Hollingsworth, Nottingham—Improvements in forming or applying tags to laces.
234. Luther Young, 8 Bow-lane, Cheapside, and Edwin Marten, 19 Louisa-street—Improvements in apparatus for regulating the pressure and supply of gas.
235. Caroline Erkmann, La Villette, near Paris, and 16 Castle-street, Holborn—Invention of the manufacture of telegraphic wires.
236. Isaac Hazlehurst, Ulverstone, Lancaster—Improvements in the manufacture of iron by blast, and in the construction of furnaces used for the same.
237. Richard Oliver, Robert Barlow, and James Blundell, Manchester—Certain improvements in machinery or apparatus for embossing and cutting out patterns or devices for the ornamentation of textile fabrics or other materials or surfaces.
238. Louis C. Koeffler, Rochdale, Lancashire—Certain improvements in machinery or apparatus for preparing, dressing, and finishing yarns or threads.
239. Louis C. Koeffler, Rochdale—Certain improvements in the method or process of scouring, washing, and oiling wool and other textile materials, for the purpose of spinning, and in the machinery or apparatus connected therewith.
240. William Wright and George Brown, Newcastle-upon-Tyne—Improvements in cupolas, which improvements are also applicable to smelting and other furnaces.
241. Pierre J. Meus, Paris—Improvements in producing metallic surfaces.

242. William Malam, Blackfriars-road, Surrey—Improvements in apparatus for the manufacture and holding of gas.
243. Richard A. Brooman, 166 Fleet-street—Improvements in the manufacture of steel.—(Communication.)
244. Philibert Beaudot, Paris, and 16 Castle-street, Holborn—Improvements in gas-burners.
245. James Jackson, Broad-street, Golden-square, and George M. Hautler, Sloane-street—Improvements in baths.

Recorded February 1.

246. Claude B. A. Chenot, Paris, and 16 Castle-street, Holborn—Improvements in accumulating, conducting, and treating gases of combustion, and also in generating and applying the same to metallurgic and other purposes.
247. Henry Wickens, 4 Tokenhouse-yard, Bank—Improvements in the mode of inter-communication in railway trains.
248. Augustin Mortera, Paris—Improvements in apparatus for stopping locomotive engines, waggons, or other vehicles on railways.
249. John Buchanan, Leamington Priors—Improvements in propellers, and applying them.
250. John Burgum, Birmingham—A new or improved self-acting damper for the furnaces of steam-hollers.
251. William Guest, Snelton, Nottinghamshire—Improvements in machinery for making whips; parts of which improvements are also applicable to the manufacture of braids and wire nets.
252. Albert Robinson, 9 Whitehall-place—Improvements in preparing compositions for coating iron and other ships' bottoms, and other surfaces.
254. Charles F. Le Page, Paris—Certain improvements in apparatus for lighting.
255. John Johnson, Litchurch Works, near Derby, and Robert Jobson, Holly Hall Works, near Dudley, Staffordshire—Improvements in the manufacture of moulds for casting metals.
256. Alfred Daniel, Dudley-road, Wolverhampton—Improvements in locks, and handles for the same.
257. James Hargreaves and James Fletcher, both of Facit, near Rochdale—Certain improvements in machinery for preparing to be spun cotton and other fibrous materials.
258. John D. Morrison, Sunderland, Durham—Improvements in winches.
259. Joseph Beattie, South-street, Lambeth—Improvements in furnaces, and in the treatment of steam.

Recorded February 2.

260. Thomas Atkins, Oxford—Improvements in transmitting power, and communicating motion to implements for agricultural and other purposes.
261. Adolphe Mohler, Obermay (Bas Rhin), France—Certain improvements in apparatus for lubricating machinery.
263. Charles E. Paris, Paris—Certain improvements in covering with metals certain metallic surfaces.
264. James Stevens, Darlington Works, Southwark Bridge-road—Improvements in apparatus for giving railway signals.
265. John H. Glassford, Glasgow—Improvements in lithographic and ziucographic printing.
266. Frederick H. Sykes, Cork-street, Piccadilly—An improved apparatus for supplying or feeding boilers with water, applicable to raising and forcing liquids for other purposes.

Recorded February 3.

268. Auguste E. L. Belford, 16 Castle-street, Holborn—A new system of apparatus, to be called "atmospheric post," for transmitting letters and messages, and applicable to railways, and as a speaking trumpet.—(Communication.)
270. Robert B. Newhouse, Uckfield, Sussex—Improved apparatus for conducting off the gases of combustion from open fireplaces.
272. Alfred Lanues Marquis of Montebello, Mareuil-sur-Aÿ, France—An improved propeller, applicable to the navigation of ships and other vessels.
274. Edward Howard and David P. Davis, Massachusetts—Improvements in machinery for sewing cloth or other material.—(Communication from Sylvester H. Roper, Massachusetts.)

Recorded February 4.

276. William Gosling, 4 Edward-street, Woolwich—Invention for the purpose of preventing collisions on railways, which he has designated "Gosling's railway danger signal."
278. Alfred V. Newton, 66 Chancery-lane—Improvements in springs applicable to railway carriages and other uses.—(Communication.)
280. William Little, Strand—Improvements in distilling or obtaining products from coals and hituminous substances.
282. Edward Cole, Hemming's-row—An improvement in the frames of travelling bags.

Recorded February 6.

284. Dominique Deyres, 16 Bateman-buildings, Soho-square—Certain improvements in drilling or boring.
288. Thomas and William Hemsley, Melbourne, Derbyshire—Improvements in the manufacture of looped fabrics.
290. Andrew Duncan, Glen House, Denny, Stirlingshire—Improvements in bleaching.
292. Peter Trumble, Huddersfield—Improvements in paper-hangings.

Recorded February 7.

294. James Murdoch, 7 Staple-inn, Holborn—An improved process for manufacturing paper.
296. Edward Poitiers, Malden-terrace, Haverstock-hill—Invention of a new material for the manufacture of cordage, canvas, and linen, and generally as a substitute for hemp and flax.
298. William J. Curtis, 23 Birch-in-lane—An improved railway signal, especially adapted as a danger signal.
300. Alphonse F. D. Duvalier, 16 Castle-street, Holborn, and Paris—Invention of a new system of remontoirs or apparatus for winding watches without a key.
302. James Taylor and Isaac Brown, Carlisle, and John Brown, Oxford-street—Improvements in the charring of animal and vegetable substances.
304. Alfred V. Newton, 66 Chancery-lane—Improved machinery for heckling flax and other fibrous materials.—(Communication.)

Recorded February 8.

306. Edward T. Rees, Prospect-place, Swindon, Wilts—Improvements in pressure slide valves in steam-engines, to be called the "Anti-pressure valve."

Information as to any of these applications, and their progress, may be had on application to the Editor of this Journal.

DESIGNS FOR ARTICLES OF UTILITY.

Registered from 19th January to 13th February, 1854.

Jan. 19th,	3553	Batty and Co., Leadenhall-street,—“Jar and cover.”
20th,	3554	H. Greaves, Birmingham,—“Portmanteau.”
23d,	3555	Waterloo and Sons, London-wall,—“Envelope.”
—	3556	H. Hill and R. Millard, Duncannon-street,—“Writing-case.”
28th,	3557	P. Arkell, Brixton-hill,—“Manger.”
31st,	3558	P. Wagenmann, Bonn, Prussia,—“Lamp.”
Feb. 2d,	3559	I. Cheek, Oxford-street,—“Hook-spinning batt.”
3d,	3560	Walsh and Brierley, Halifax,—“Waistband clasp.”
4th,	3561	W. Oxley and Co., Manchester,—“Flyer-wasber.”
7th,	3562	H. T. Boden, Birmingham,—“Tooth brush.”
13th,	3563	W. Aston, Birmingham,—“Button.”

DESIGNS FOR ARTICLES OF UTILITY,

Provisionally Registered.

Jan. 16th,	555	T. Lavender, Goswell-road,—“Cinder-sifter.”
19th,	556	Carl Von Berg, Bath-street,—“Miniature-case catch.”
20th,	557	J. Stoker, Doncaster,—“Signal-break.”
31st,	558	C. J. Recordon, Barnstable,—“Angle trisector.”
Feb. 2d,	559	T. Glozhegan, Jermy-street,—“Raglan surtout.”
8th,	560	G. Graee, Birmingham,—“Screw-nicking machine.”
—	561	E. Aldis, North-street,—“Cramp.”

TO READERS AND CORRESPONDENTS.

COMPLETION OF THE 6TH VOLUME OF THE "PRACTICAL MECHANIC'S JOURNAL."—The present Part, No. 72, completes the 6th Volume of this Journal, and the set may be had from any bookseller, in cloth, lettered, price 14s. each, or the whole 72 Parts separately, for binding, to suit the purchaser. The set may also be had, handsomely bound in half-calf, and lettered, to form three double volumes, with the Plates bound separately, to correspond, price 31s. 6d. for each double volume and volume of Plates. Volume VI. contains 27 quarto pages of copperplate engravings, and nearly 700 engravings on wood.

THE PRACTICAL DRAUGHTSMAN'S BOOK OF INDUSTRIAL DESIGN.—This work is now complete. It is composed of 13 Parts, price 2s. each. The whole forms a volume of 200 pages of letter-press, 105 quarto pages of copperplate engravings of the highest class, and 60 wood engravings. Price, complete, in cloth, gold-lettered, £1. 9s. Any of the Parts can be had separately.

SCIENCE.—Wheels set on separate axes have already been proposed to work with his system of articulated connections. All such plans have been given up as impracticable; and we regret that our correspondent's modification does not alter our views on the subject.

T. WALKER, Manchester, gives us no further address, consequently we have been unable to reply to his inquiries. Several life-boats have appeared in our pages. His bookseller will advise him how to obtain the parts.

J. G., Halifax.—The address is "Old Kent Road, London."

RECEIVED.—"Analytical Physics, or Trinitology," by R. Forfar.—"The Crystal Palace and Park in 1853; what has been done, and what will be done, addressed to Intending Exhibitors."—"Sub-Arch Railways in the Streets of London." By John Williams.—"On Peruvian Guano," by J. C. Nesbit.—"A Letter to the Right Hon. the Earl of Aberdeen on the New War Shell," by J. A. Smith.—"People's Journal." New York. Parts I. to IV.

MONTGOMERY.—It is made by SWORD, 22 South Hanover Street, Edinburgh. Personal examination is the only guide as to actual value. The mill our correspondent mentions is, we believe, a good one; but the particulars asked for are obtainable only from the maker.



4 Apr. 1854.





SMITHSONIAN INSTITUTION LIBRARIES



3 9088 01549 2275